

Video Camera Recorder

Operation Manual

Before operating the unit, please read this manual thoroughly, and retain it for future reference.

Owner's record

The model and serial numbers are located on the bottom. Record the serial number in the space provided below. Refer to these numbers whenever you call upon your Sony dealer regarding this product.

Model No. CCD-

Model No. AC-

Serial No. _____

Serial No. _____

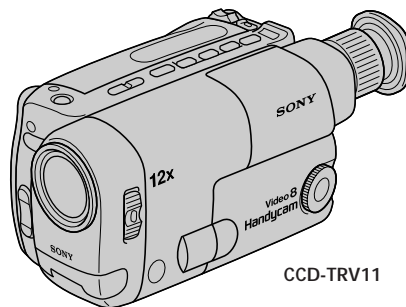

Video Handycam

CCD-TRV11/TRV19/TRV21

CCD-TRV29/TRV119/TRV211

© 1996 by Sony Corporation

Welcome to video

Congratulations on your purchase of this Sony Handycam® camcorder. With your Handycam, you can capture life's precious moments with superior picture and sound quality. Your Handycam is loaded with advanced features, but at the same time it is very easy to use. You will soon be producing home video that you can enjoy for years to come.

WARNING

To prevent fire or shock hazard, do not expose the unit to rain or moisture.

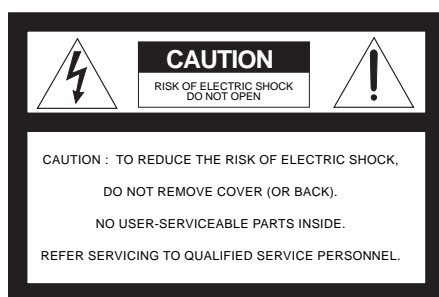

This symbol is intended to alert the user to the presence of uninsulated "dangerous voltage" within the product's enclosure that may be of sufficient magnitude to constitute a risk of electric shock to persons.



This symbol is intended to alert the user to the presence of important operating and maintenance (servicing) instructions in the literature accompanying the appliance.

RECYCLING NICKEL-CADMIUM BATTERIES



NICKEL-CADMIUM BATTERY. MUST BE DISPOSED OF PROPERLY.

Ni-Cd

Nickel-Cadmium batteries are recyclable. You can help preserve our environment by returning your unwanted batteries to your nearest Sony Service Center or Factory Service Center for collection, recycling or proper disposal.

Note: In some areas the disposal of nickel-cadmium batteries in household or business trash may be prohibited.

For the Sony Service Center nearest you call 1-800-222-SONY (United States only).
For the Factory Service Center nearest you call 416-499-SONY (Canada only).

Caution: Do not handle damaged or leaking nickel-cadmium batteries.

For the Customers in the U.S.A.

WARNING

This equipment has been tested and found to comply with the limits for a Class B digital device, pursuant to Part 15 of the FCC Rules. These limits are designed to provide reasonable protection against harmful interference in a residential installation. This equipment generates, uses, and can radiate radio frequency energy and, if not installed and used in accordance with the instructions, may cause harmful interference to radio communications. However, there is no guarantee that interference will not occur in a particular installation. If this equipment does cause harmful interference to radio or television reception, which can be determined by turning the equipment off and on, the user is encouraged to try to correct the interference by one or more of the following measures:

- Reorient or relocate the receiving antenna.
- Increase the separation between the equipment and receiver.
- Connect the equipment into an outlet on a circuit different from that to which the receiver is connected.
- Consult the dealer or an experienced radio/TV technician for help.

You are cautioned that any changes or modifications not expressly approved in this manual could void your authority to operate this equipment.

For the Customers in CANADA

CAUTION

TO PREVENT ELECTRIC SHOCK, DO NOT USE THIS POLARIZED AC PLUG WITH AN EXTENSION CORD, RECEPTACLE OR OTHER OUTLET UNLESS THE BLADES CAN BE FULLY INSERTED TO PREVENT BLADE EXPOSURE.

Table of contents

Before you begin

- Using this manual 4
- Checking supplied accessories 5

Getting started

- Charging and installing the battery pack 6
- Inserting a cassette 8

Basic operations

- Camera recording 9
 - Using the zoom feature 11
 - Shooting with the LCD screen 12
- Hints for better shooting 13
- Checking the recorded picture 15
- Playing back a tape 16
- Searching for the end of the picture ... 18

Advanced operations

- Using alternative power sources 19
- Letting the subject monitor the shot . 21
- Recording with the date or time 22
- Shooting with backlighting 23
- Using the PROGRAM AE function 24
- Selecting the START/STOP mode 25
- Superimposing a title 26
- Using the STEADY SHOT function ... 27
(CCD-TRV21/TRV29/TRV211 only)
- Changing the mode settings 28
- Watching on a TV screen 29
- Editing onto another tape 30

Additional information

- Changing the lithium battery in the camcorder 31
- Resetting the date and time 33
- Playback modes 34
- Tips for using the battery pack 34
- Maintenance information and precautions 38
- Using your camcorder abroad 42
- Trouble check 43
- Specifications 46
- Identifying the parts 47
- Warning indicators 55
- Index back cover

Before you begin

Using this manual

The instructions in this manual are for the six models listed below. Before you start reading this manual and operating the unit, check your model number by looking at the bottom of your camcorder. The CCD-TRV11 is the model used for illustration purposes. Otherwise, the model name is indicated in the illustrations. Any differences in operation are clearly indicated in the text, for example, “ CCD-TRV21/TRV29/TRV211 only”.

As you read through this manual, buttons and settings on the camcorder are shown in capital letters.

e.g. Set the POWER switch to CAMERA.

As indicated with \flat in the illustrations, you can hear the beep sound to confirm your operation.

Types of differences

Model	Viewfinder		Zoom	Steady Shot
	B/W	Color		
CCD-TRV11	●		12X	
CCD-TRV19		●	12X	
CCD-TRV21	●		12X ↔ 24X	●
CCD-TRV29		●	12X ↔ 24X	●
CCD-TRV119		●	12X	
CCD-TRV211	●		12X ↔ 24X	●

Note on TV color systems

TV color systems differ from country to country.

To view your recordings on a TV, you need an NTSC system-based TV.

Precaution on copyright

Television programs, films, video tapes, and other materials may be copyrighted.

Unauthorized recording of such materials may be contrary to the provision of the copyright laws.

Precautions on camcorder care

- Do not let the camcorder get wet. Keep the camcorder away from rain and sea water. It may cause a malfunction and sometimes the malfunction cannot be repaired. [a]
- Do not let sand get into the camcorder. When you use the camcorder on a sandy beach or in a dusty place, protect it from the sand or dust. Sand or dust may cause the unit to malfunction, and sometimes this malfunction cannot be repaired. [b]
- Never leave the camcorder under temperatures above 140° F (60 °C), such as in a car parked in the sun or under direct sunlight. [c]

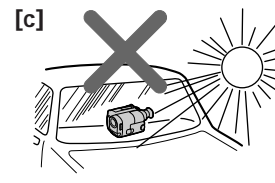
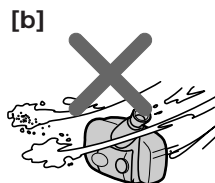

Checking supplied accessories

Check that the following accessories are supplied with your camcorder.

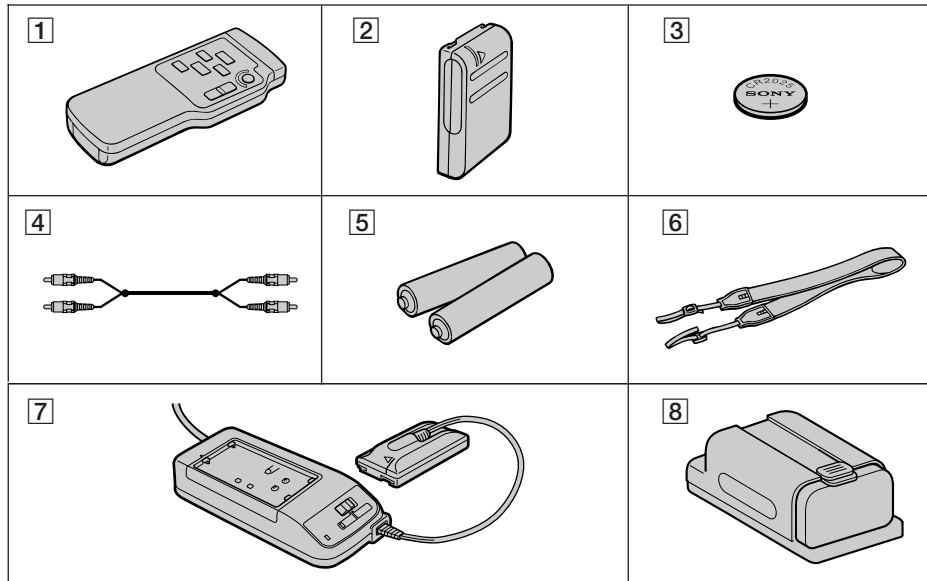

- | | |
|---|--|
| <p>1 Wireless Remote Commander (1) (p. 17, 51)</p> | <p>5 Size AA (R6) battery for Remote Commander (2) (p. 52)</p> |
| <p>2 NP-33 Battery Pack (1) (p. 6)</p> | <p>6 Shoulder strap (1) (p. 49)</p> |
| <p>3 CR2025 Lithium Battery (1) (p. 31)
Already installed in the camcorder.</p> | <p>7 AC-V15/V16/V16A AC power adaptor (1) (p. 6, 19)</p> |
| <p>4 A/V connecting cable (1) (p. 29)</p> | <p>8 Battery case (1) (p. 20)
CCD-TRV11/TRV19/TRV21/TRV29 only</p> |

Contents of the recording cannot be compensated if recording or playback is not made due to a malfunction of the camcorder, video tape, etc.

Before you begin

Getting started

Charging and installing the battery pack

Before using your camcorder, you first need to charge and install the battery pack. To charge the battery pack, use the supplied AC power adaptor.

Charging the battery pack

Charge the battery pack on a flat place without vibration.

- (1) Connect the AC power adaptor to the wall outlet.
- (2) Align the right side of the battery pack with the line on the AC power adaptor, then slide the battery pack in the direction of the arrow.
- (3) Set the selector to CHARGE. The CHARGE lamp (orange) lights up. Charging begins.

When charging is completed, the CHARGE lamp goes out. Unplug the unit from the wall outlet, and then remove the battery pack and install it on the camcorder.

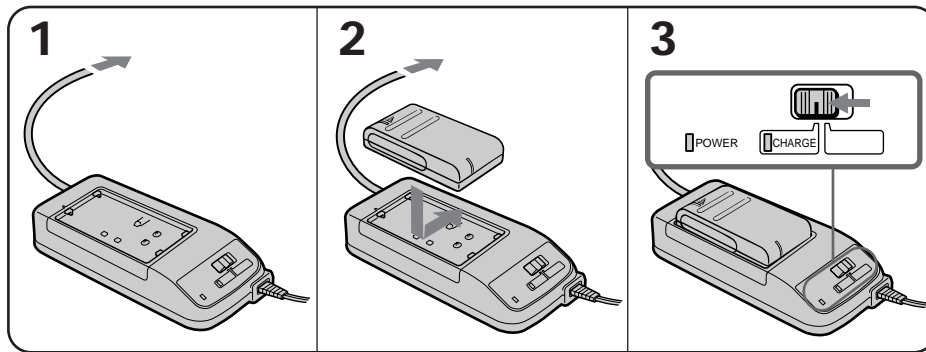

Charging Time

Battery pack	NP-33(supplied)	NP-55	NP-98/98D	NP-80/80D	NP-68/66H	NP-66	NP-C65	NP-60D
Charging time*(min)	60	70	215	190	125	95	105	90

*Approximate minutes to charge an empty battery pack using the supplied AC power adaptor. (Lower temperatures require a longer charging time.)

Battery life

CCD-TRV11/TRV19/TRV119

Battery pack		NP-33(supplied)	NP-55	NP-98/98D	NP-80/80D	NP-68/66H	NP-66	NP-C65	NP-60D
While recording ¹⁾	LCD open ²⁾	70 (30)	75 (40)	225 (120)	200 (110)	140 (75)	110 (60)	120 (65)	100 (55)
	LCD close	90 (45)	95 (55)	305 (170)	265 (150)	180 (100)	150 (85)	155 (85)	135 (75)
While playing back on LCD ³⁾		65	75	225	195	140	110	115	100

CCD-TRV21/TRV29/TRV211

Battery pack		NP-33(supplied)	NP-55	NP-98/98D	NP-80/80D	NP-68/66H	NP-66	NP-C65	NP-60D
While recording ¹⁾	LCD open ²⁾	60 (30)	70 (35)	210 (110)	185 (100)	130 (70)	100 (50)	105 (55)	95 (50)
	LCD close	80 (40)	85 (50)	275 (155)	240 (135)	165 (95)	135 (75)	145 (80)	120 (70)
While playing back on LCD ³⁾		65	70	220	190	135	105	100	95

- ¹⁾ Approximate continuous recording time indoors is indicated outside of parentheses. Approximate minutes when recording while you repeat recording start/stop, zooming and turning the power on/off are indicated in parentheses. The actual battery life may be shorter.
- ²⁾ Approximate minutes when using the LCD screen. When using both the viewfinder and LCD screen, the battery life is shorter.
- ³⁾ Approximate continuous playback time indoors.

If the LCD BACK LIGHT switch is set to BRIGHT while the LCD screen is open, the battery life is approximately 10% shorter.

To remove the battery pack

Slide the battery pack in the direction of the arrow.

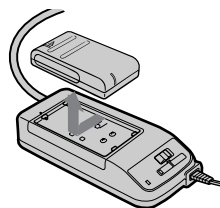
**Notes on charging the battery pack**

- The POWER lamp will remain lit for a while even if the battery pack is removed and the power cord is unplugged after charging the battery pack. This is normal.
- If the POWER lamp does not light, set the selector to VTR (DC OUT) and disconnect the power cord. After about one minute, reconnect the power cord and set the selector to CHARGE again.
- You cannot operate the camcorder using the AC power adaptor while charging the battery pack.

Installing the battery pack

- (1) Insert the top of the battery pack into the top of the battery mounting surface.
- (2) Push the battery pack so that it attaches firmly.

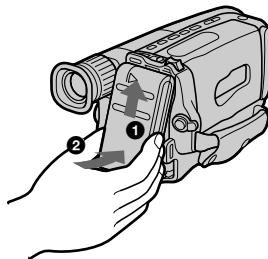

Charging and installing the battery pack

To remove the battery pack

Slide BATT, and then pull the lower part of the battery pack.

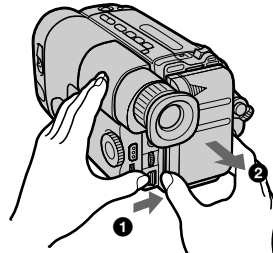

Inserting a cassette

Make sure that a power source is installed.

- (1) While pressing the small blue button, slide EJECT in the direction of the arrow. The cassette compartment automatically opens.
- (2) Insert a cassette (not supplied) with the window facing out.
- (3) Press the PUSH mark on the cassette compartment to close it. The cassette compartment automatically closes.

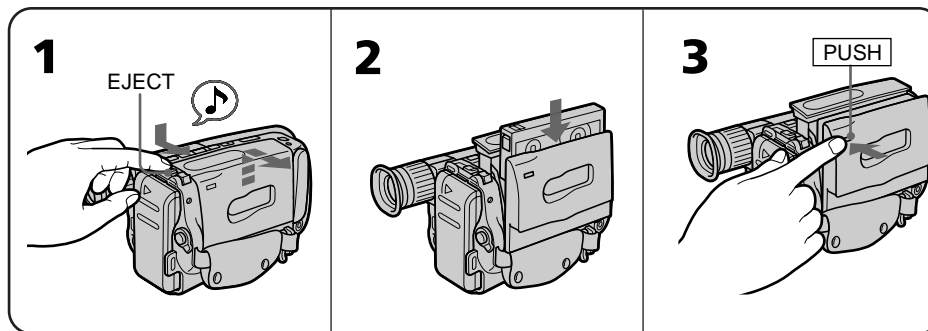



To eject the cassette

While pressing the small blue button, slide EJECT in the direction of the arrow.

To prevent accidental erasure

Slide the tab on the cassette to expose the red mark.

If you insert the cassette with the red mark exposed and close the cassette compartment, the beeps sound for a while. If you try to record with the red mark exposed, the  and  indicators flash in the viewfinder, and you cannot record.

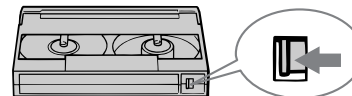

To re-record on this tape, slide the tab back out covering the red mark.

Basic operations

Camera recording

Make sure that a power source and a cassette is inserted and that the START/STOP MODE switch inside the LCD panel is set to .

When you use the camcorder for the first time, power on it and reset the date and time to your time (p. 33) before you start recording. The date is automatically recorded for 10 seconds after you start recording (AUTO DATE feature). This feature works only once a day.

Before you record one-time events, you may want to make a trial recording to make sure that you are using the camcorder correctly.

- (1) While pressing the small green button on the POWER switch, set it to CAMERA.
- (2) Turn STANDBY up. The "STBY" indicator appears in the viewfinder.
- (3) Press START/STOP. The camcorder starts recording and the "STBY" indicator changes to the "REC" indicator.

You can also select Recording mode, SP (standard play) mode or LP (long play) mode. Set REC MODE (p. 28) according to the length of your planned recording before you start.

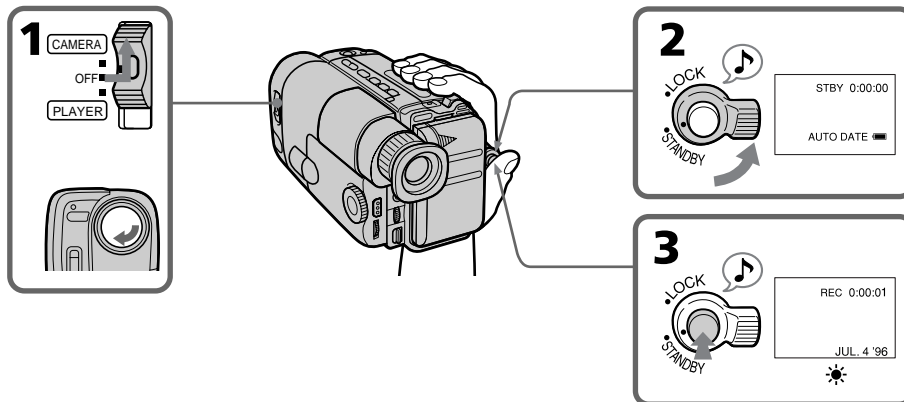

To stop recording momentarily [a]

Press START/STOP again. The "REC" indicator in the viewfinder changes to the "STBY" indicator (Standby mode).

To finish recording [b]

Press START/STOP. Turn STANDBY down, and set the POWER switch to OFF. Then, eject the cassette and remove the battery pack.

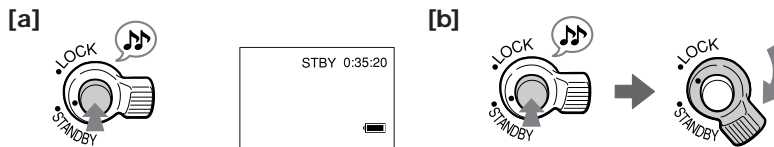

Camera recording

Note on standby mode

If you leave the camcorder for 5 minutes or more with a cassette inserted in Standby mode, the camcorder goes off automatically. This prevents wearing down the battery and wearing out the tape. To resume Standby mode, turn STANDBY down once and turn it up again. To start recording, press START/STOP.

Notes on the recording mode

- This camcorder records and plays back in SP (standard play) mode and in LP (long play) mode.
The playback quality in LP mode, however, will not be as good as that in SP mode.
- When a tape recorded on this camcorder in LP mode is played back on other types of 8 mm camcorders or VCRs, the playback quality may not be as good as that on this camcorder.

To focus the viewfinder lens

If the viewfinder is not in focus at all or when you use the camcorder after someone else has used it, focus the viewfinder lens. Turn the viewfinder lens adjustment ring so that the indicators in the viewfinder come into sharp focus.

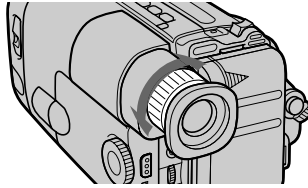

Recording with the START/STOP button depressed

You can also make recording while pressing down the START/STOP button. To make the START/STOP button work this way, slide START/STOP MODE to . [a]

Shooting scenery in several short takes

You can automatically make a recording for about 5 seconds with the 5 SEC mode (p. 25). To make the START/STOP button work this way, slide START/STOP MODE to . [b]

[a] START/STOP MODE

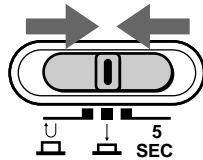

[b] START/STOP MODE

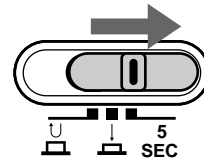

Note on recording

When you record from the beginning of the tape, run the tape for about 15 seconds before actual recording. This prevents the camcorder from missing any start-up scenes when you play back the tape.

Notes on the tape counter

- The tape counter indicates the recording or playback time. Use it as a guide. There will be a time lag of several seconds from the actual time. To set the counter to zero, press COUNTER RESET.
- If the tape is recorded in SP and LP modes mixed, the tape counter shows incorrect recording time. When you intend to edit the tape using the tape counter, record in same (SP or LP) mode.

Note on beep sound

As indicated with ♪ in the illustrations, a beep sounds when you turn the power on or when you start recording and two beeps sound when you stop recording, confirming the operation. Several beeps also sound as a warning of any unusual condition of the camcorder. Note that the beep sound is not recorded on the tape. If you do not want to hear the beep sound, change the BEEP setting to OFF.

Note on the AUTO DATE feature

The clock is set to East Coast Standard Time at the factory. You can reset the clock. The AUTO DATE feature shows the date automatically once a day. However, the date may automatically appear more than once a day when:

- you reset the date and time.
- you eject and insert the tape again.
- you stop recording within 10 seconds.

When moving from indoors to outdoors (or vice versa)

Turn STANDBY up and point the camcorder at a white object for about 15 seconds so that the white balance is properly adjusted.

Using the zoom feature

Zooming is a recording technique that lets you change the size of the subject in the scene. For more professional-looking recordings, use the zoom sparingly.

T side: for telephoto (subject appears closer)

W side: for wide-angle (subject appears farther away)

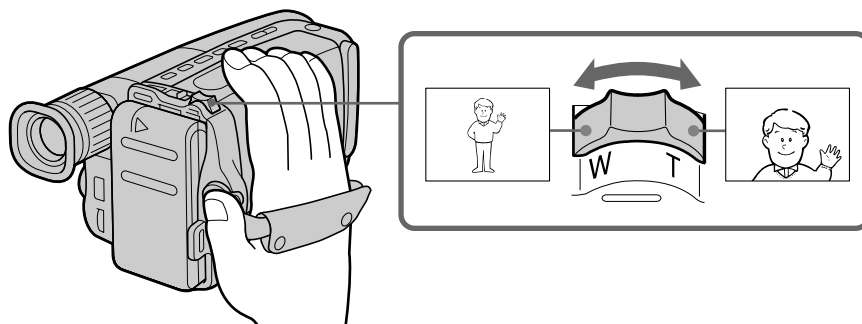

Camera recording

Zooming speed (Variable speed zooming)

Turn the power zoom lever fully for a high-speed zoom. Turn it lightly for a relatively slow zoom.

When you shoot a subject using a telephoto zoom

If you cannot get a sharp focus while in extreme telephoto zoom, move the power zoom lever to the "W" side until the focus is sharp.

You can shoot a subject that is at least 2.6 feet (about 80 cm) away from the lens surface in the telephoto position, or 1/2 inches (about 1 cm) in the wide-angle position.

Notes on digital zoom (CCD-TRV21/TRV29/TRV211 only)

- More than 12x zoom is performed digitally, and the picture quality deteriorates as you go toward the "T" side. If you do not want to use the digital zoom, set the D ZOOM function to OFF.
- The vertical bar in the power zoom indicator separates the digital zooming zone (right side of the bar [a]) and the optical zooming zone (left side of the bar [b]). If you set the D ZOOM function to OFF, the right side of the bar [a] disappears.

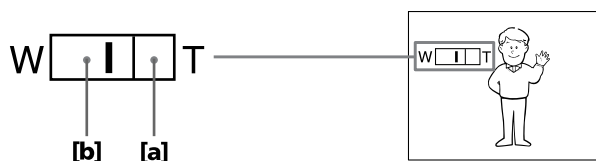

Shooting with the LCD screen

You can also record the picture while looking at the LCD screen.

When using the LCD screen, the viewfinder turns off automatically. You cannot monitor the sound from the speaker during recording.

(1) While pressing PUSH OPEN, open the LCD panel.

(2) Adjust the angle of the LCD panel.

The LCD panel moves about 90 degrees to this side and about 210 degrees to the other side.

To adjust the brightness of the LCD screen, turn the BRIGHT dial.

The battery life is longer when the LCD panel is closed. Use the viewfinder instead of the LCD screen to save the battery power.

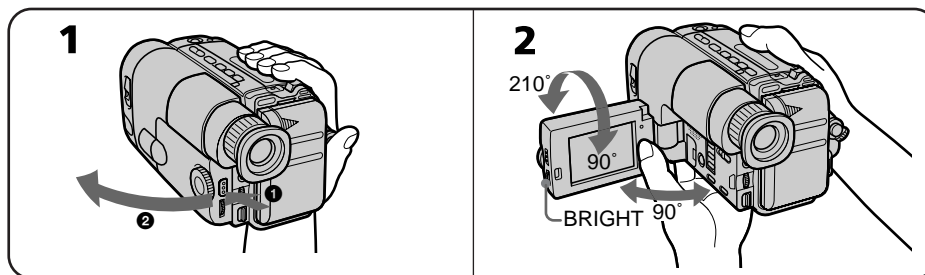

Notes on the LCD panel

- When closing the LCD panel, turn it vertically until it clicks [a].
- When turning the LCD panel, turn it always vertically; otherwise, the camcorder body may be damaged or the LCD panel may not close properly [b].
- Close the LCD panel completely when not in use.

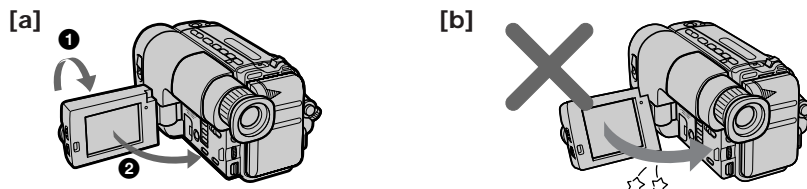
**Hints for better shooting**

For hand-held shots, you'll get better results by holding the camcorder according to the following suggestions:

- Hold the camcorder firmly and secure it with the grip strap so that you can easily manipulate the controls with your thumb.

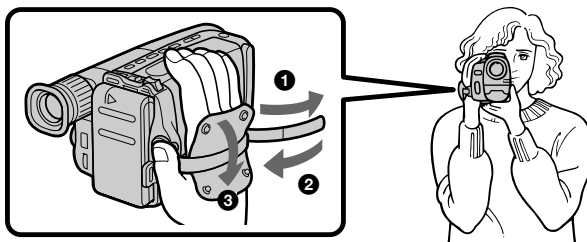

- Place your right elbow against your side.
- Place your left hand under the camcorder to support it.
- Place your eye firmly against the viewfinder eyecup.
- Use the viewfinder frame as a guide to determine the horizontal plane.

Hints for better shooting

- You can record in a low position to get an interesting recording angle. Lift the viewfinder up for recording from a low position [a].
- While recording in a low position, you can use the START/STOP button on the top of the camcorder or the power zoom button located on the front [b]. Note that you cannot change zooming speed using the front power zoom button.
- You can also record in a low position or even in a high position using the LCD panel [c].

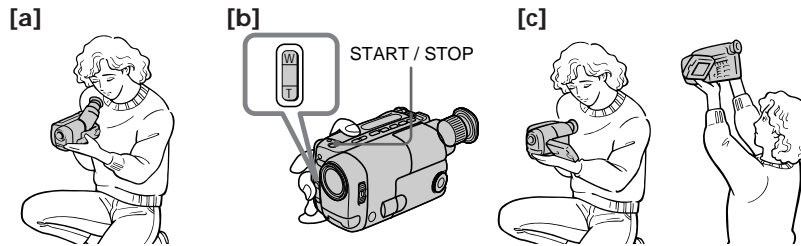

Place the camcorder on a flat surface or use a tripod

Try placing the camcorder on a table top or any other flat surface of suitable height. If you have a tripod for a still camera, you can also use it with the camcorder. When attaching a non-Sony tripod, make sure that the length of the tripod screw is less than 9/32 inches (6.5 mm). Otherwise, the screw may damage the inner parts of the camcorder.

Cautions on the viewfinder and the LCD

- Do not pick up the camcorder by the viewfinder or by the LCD panel [d].
- Do not place the camcorder so as to point the viewfinder or the LCD screen toward the sun. The inside of the viewfinder or the LCD panel may be damaged. Be careful when placing the camcorder under sunlight or by a window [e].

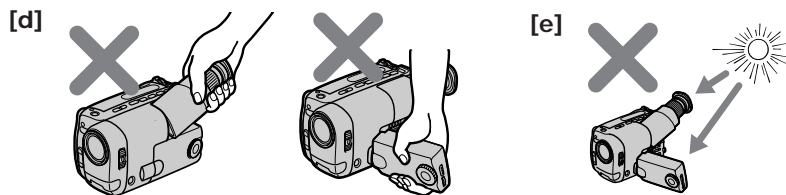

Note on the color viewfinder (CCD-TRV19/TRV29/TRV119 only) and the LCD screen

The color viewfinder and the LCD screen are made with high-precision technology. However, black points or bright points of light (red, blue, or green) may appear on the color viewfinder and the LCD screen. These points are not recorded on the tape. This is not a malfunction. (Effective dots: more than 99.99%)

Notes on the LCD screen

- When you use the LCD screen outdoors in direct sunlight, the LCD screen may be difficult to see. If this happens, we recommend that you use the viewfinder.
- The LCD itself contains over 61,000 picture elements (pixels) for 2.5 inches LCD. High Precision technology is used to manufacture these LCDs to maintain a high standard that at least 99.99% of the pixels operate, however, some of the pixels may not change color. This is normal and in no way does this affect the picture that is being recorded.

Checking the recorded picture

Using EDITSEARCH, you can review the last recorded scene or check the recorded picture in the viewfinder. You can also review the picture on the LCD screen.

- (1) While pressing the small green button on the POWER switch, set it to CAMERA.
- (2) Turn STANDBY up.
- (3) Press the - (⊖) side of EDITSEARCH momentarily; the last few seconds of the recorded portion plays back (Rec Review). You can also monitor the sound from the speaker or by using an earphone (not supplied).

Hold down the - side of EDITSEARCH until the camcorder goes back to the scene you want. The last recorded portion is played back. To go forward, hold down the + side (Edit Search).

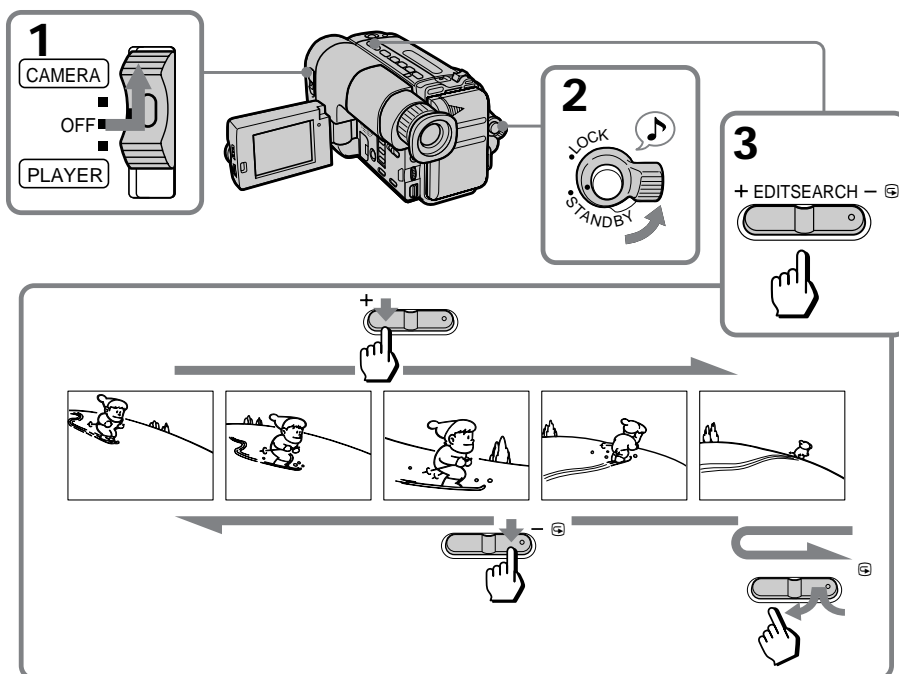

To stop playback

Release EDITSEARCH.

To go back to the last recorded point after edit search

Press END SEARCH. The last recorded point is played back for about 5 seconds if the tape was recorded in SP mode, or 10 seconds if the tape was recorded in LP mode, and stops.

Note that this function does not work once you eject the cassette after you recorded in the tape.

To begin re-recording

Press START/STOP. Re-recording begins from the last recorded point or the point you released EDITSEARCH. Provided you do not eject the tape, the transition between the last scene you recorded and the next scene you record will be smooth.

Playing back a tape

You can monitor the playback picture on the LCD screen.

- (1) While pressing the small green button on the POWER switch, set it to **PLAYER**.
- (2) Insert the recorded tape with the window facing out.
- (3) While pressing **PUSH OPEN**, open the LCD panel. Adjust the angle of the LCD panel or the brightness of the LCD screen if necessary.
- (4) Press **▶** to start playback.
- (5) Adjust the volume using **VOL.**

You can also monitor on the TV screen after connecting the camcorder to the VCR/TV.

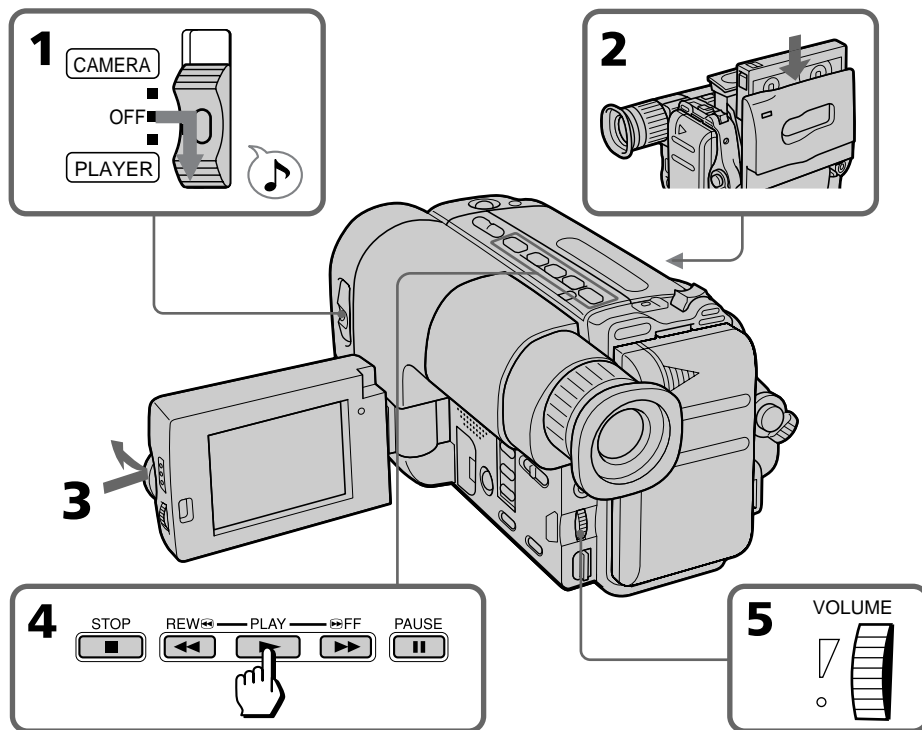

- To stop playback, press ■.
- To rewind the tape, press ◀◀.
- To fast-forward the tape, press ▶▶.

When watching on the LCD screen

You can turn the LCD panel over and move back to the camcorder with the LCD screen facing out. **[a]**

You can change the angle of the LCD panel. **[b]**

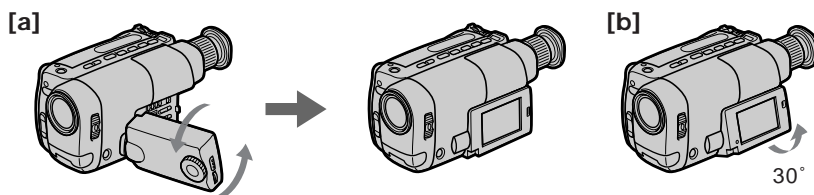

Using the Remote Commander

You can control playback using the supplied Remote Commander.

Before using the Remote Commander, insert the size AA (R6) batteries.

Note on DISPLAY button

Press DISPLAY to erase the screen indicators on the LCD screen. To display the indicators, press again.

The indicators don't appear on the TV.

Using an earphone

Connect an earphone (not supplied) to the \odot jack. You can adjust the volume of the earphone using VOL.

To view the playback picture in the viewfinder

Close the LCD panel. The viewfinder turns on automatically. When using the viewfinder, you can monitor the sound only by using an earphone.

To view on the LCD screen again, open the LCD panel. The viewfinder turns off automatically.

Various playback modes

To view a still picture (playback pause)

Press II during playback. To resume playback, press II or \blacktriangleright .

To locate a scene (Picture Search)

Keep pressing \blacktriangleleft or \blacktriangleright during playback. To resume normal playback, release the button.

To monitor the high-speed picture while advancing the tape or rewind (Skip Scan)

Keep pressing \blacktriangleleft while rewinding or \blacktriangleright while advancing the tape.

To resume normal playback, press \blacktriangleright .

Notes on playback

- Streaks appear and the sound is muted in the various playback modes.
- When playback pause mode lasts for 5 minutes more, the camcorder automatically enters stop mode.

Searching for the end of the picture

You can go to the end of the recorded portion after you record and play back the tape to make the transition between the last scene you recorded and the next scene smooth. The tape starts rewinding or fast-forwarding and the last 5 seconds play back if the tape was recorded in SP mode, or the last 10 seconds play back if the tape was recorded in LP mode. Then the tape stops at the end of the recorded picture (**End Search**).

Note that End Search function does not work once you eject the cassette after you recorded in the tape.

(1) While pressing PUSH OPEN, open the LCD panel.

(2) Press END SEARCH.

This function works when the POWER switch is set to either CAMERA or PLAYER.

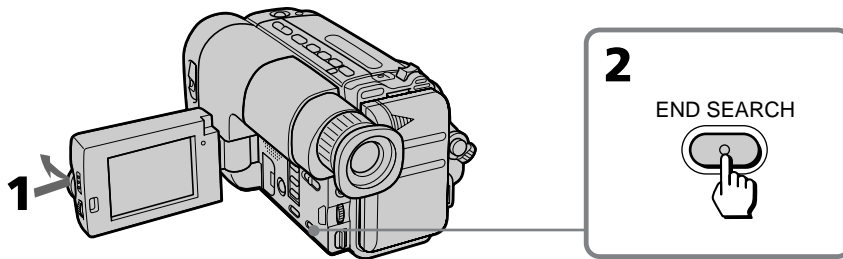

Advanced operations

Using alternative power sources

You can choose any of the following power sources for your camcorder: battery pack, the house current, alkaline battery and 12/24 V car battery. Choose the appropriate power source depending on where you want to use your camcorder.

	Power source	Accessory to be used
Indoors	House current	Supplied AC power adaptor
Outdoor	Battery pack	Battery pack (Ni-Cd type)
	Size AA (LR 6) Alkaline battery	Battery case (supplied)
In the car	12 V or 24 V car battery	DC pack DCP-77

Note on power sources

Disconnecting the power source or removing the battery pack during recording or playback may damage the inserted tape. If this happens, restore the power supply again immediately.



This mark indicates that this product is a genuine accessory for Sony video product. When purchasing Sony video products, Sony recommends that you purchase accessories with this "GENUINE VIDEO ACCESSORIES" mark.

Using the house current

To use the supplied AC power adaptor:

- (1) Connect the power cord to a wall outlet. Insert the top of the connecting plate of the AC power adaptor into the top of the battery mounting surface. Push the connecting plate so that it attaches firmly.
- (2) Set the selector to VTR (DC OUT).

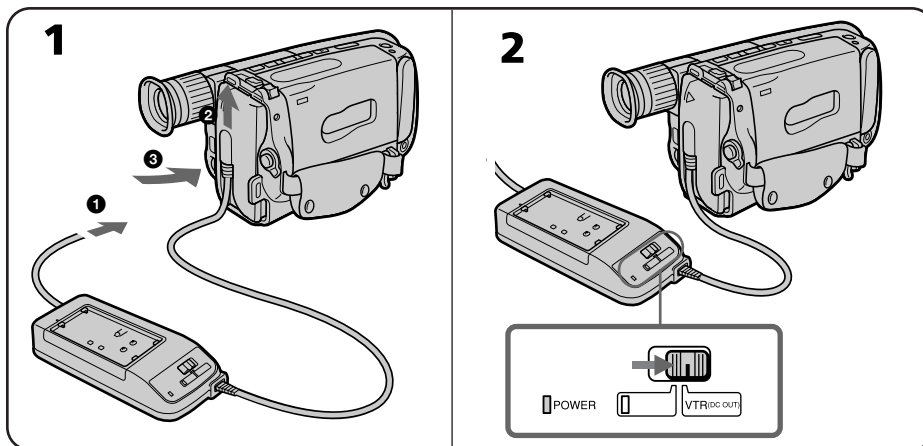

WARNING

Power cord must only be changed at qualified service shop.

PRECAUTIONS

The set is not disconnected from the AC power source as long as it is connected to the wall outlet, even if the set itself has been turned off.

Using alternative power sources

Notes on the POWER lamp

- The POWER lamp will remain lit for a while even if the unit is unplugged after use. This is normal.
- If the POWER lamp does not light, set the selector to VTR (DC OUT) and disconnect the power cord. After about one minute, reconnect the power cord.

To remove the adaptor

The adaptor is removed in the same way as the battery pack.

Using the Battery Case

- CCD-TRV11/TRV19/TRV21/TRV29 only

Use the battery case (supplied) and six size AA (LR6) alkaline batteries (not supplied).

- (1) Remove the battery holder from the battery case.
- (2) Insert six new alkaline batteries into the battery holder, following the marking on the holder to be sure the batteries are installed in the correct direction.
- (3) Insert the battery holder with the alkaline batteries.
- (4) Insert the battery case with the alkaline batteries to the battery mounting surface of the camcorder in the same way as the battery pack (p. 7).

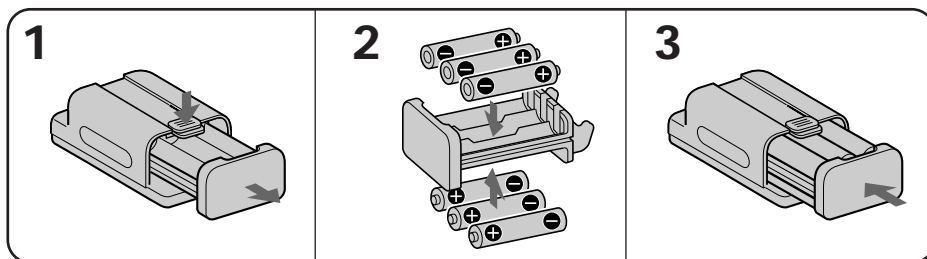

Battery Life

Using alkaline batteries at 77°F (25°C)

Model		CCD-TRV11/TRV19	CCD-TRV21/TRV29
While recording ¹⁾	LCD open ²⁾	125 (70)	110 (60)
	LCD close	170 (95)	150 (85)
While playing back on LCD ³⁾		120	115

¹⁾ Approximate continuous recording time indoors is indicated outside of parentheses. Approximate minutes when recording while you repeat recording start/stop, zooming and turning the power on/off are indicated in parentheses. The actual battery life may be shorter.

²⁾ Approximate minutes when using the LCD screen. When using both the viewfinder and LCD screen, the battery life is shorter.

³⁾ Approximate continuous playback time indoors.

If the LCD BACK LIGHT switch is set to BRIGHT while the LCD screen is open, the battery life is approximately 10% shorter.

Notes

- The above battery lives are estimates. The battery life may be shorter depending on the storage condition of the battery before being purchased and temperature.
- You may not use the battery case in cold environment.

To remove the battery case

The battery case is removed in the same way as the battery pack (p. 7).

When you replace the batteries, be sure to remove the battery case from the camcorder to prevent malfunction.

Using a car battery

Use the DCP-77 DC pack (not supplied). Connect the cord of the DC pack to the cigarette lighter socket of the car (12 V or 24 V). Connect the DC pack to the battery mounting surface of the camcorder.

To remove the DC pack

The DC pack is removed in the same way as the battery pack.

Letting the subject monitor the shot

You can turn the LCD panel over so that it faces the other way and you can let the subject monitor the shot while shooting with the viewfinder.

Turn the LCD panel vertically first until it clicks, then turn it over. The ☺ indicator appears on the LCD screen (Mirror mode) and the date and remaining battery indicators disappear.

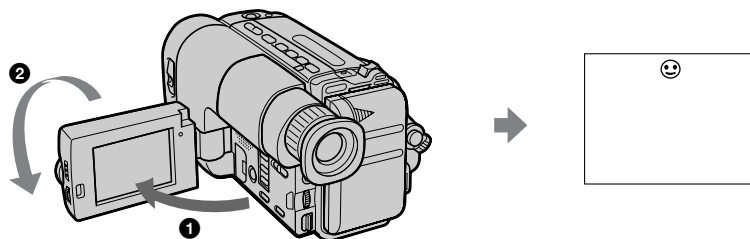
**To cancel mirror mode**

Turn the LCD panel back toward the viewfinder.

Notes on mirror mode

- When you turn the LCD panel about 135 degrees to 210 degrees, the camcorder enters mirror mode.
- Using the mirror mode, you can record yourself while watching yourself on the LCD [a].
- The picture on the LCD looks as a mirror-image while recording in mirror mode [b]. The STBY indicator appears as ●|| and REC as ●.
- The date appears in reverse when the AUTO DATE feature is turned on. When recorded it will be normal.

Letting the subject monitor the shot

- While recording in mirror mode, you cannot operate the following buttons: COUNTER RESET, TITLE, DATE(+) and TIME(NEXT).

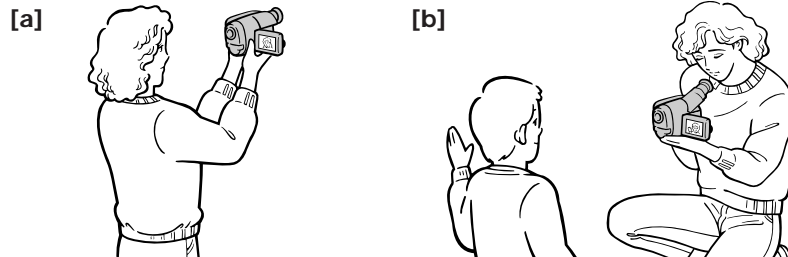

Recording with the date or time

Before you start recording or during recording, press DATE(+) or TIME(NEXT). You can record the date or time displayed on the LCD screen or in the viewfinder with the picture. You cannot record the date and time at the same time. Except for the date or time indicator, no indicator on the LCD screen or in the viewfinder is recorded. The clock is set to East Coast Standard Time at the factory.

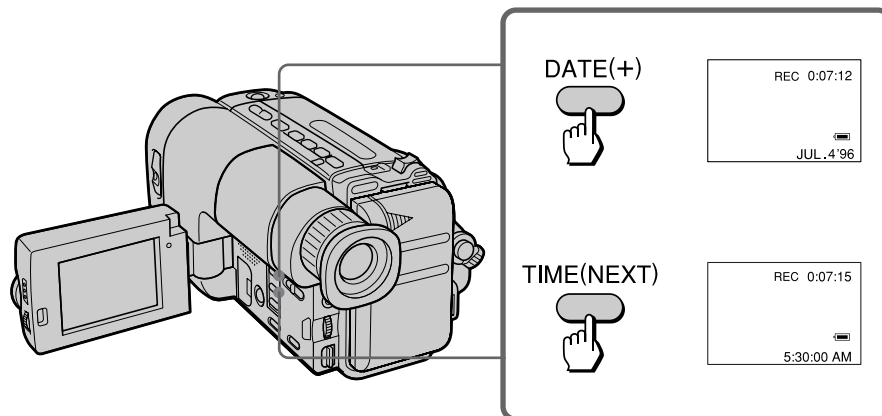

To stop recording with the date or time

Press DATE(+) or TIME(NEXT) again. The date or time indicator disappears. The recording continues.

Note

You cannot superimpose a title during recording the date or time.

Shooting with backlighting

When you shoot a subject with the light source behind the subject or a subject with a light background, use the BACK LIGHT function.

Press BACK LIGHT. The  indicator appears in the viewfinder or on the LCD screen.

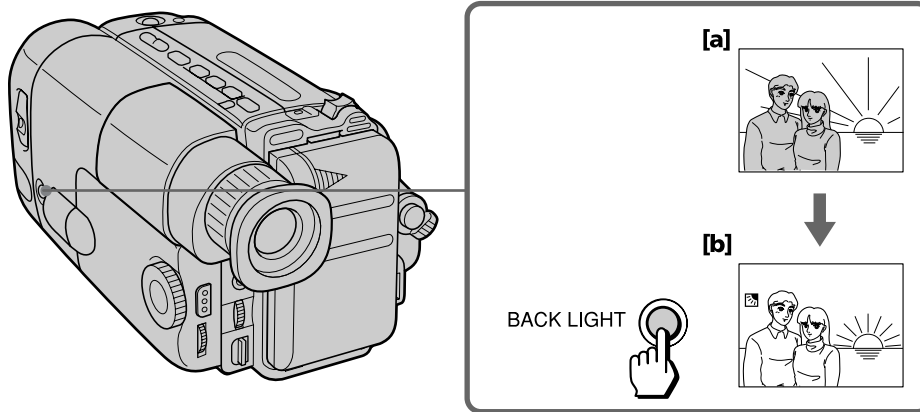

Advanced operations

[a] Subject is too dark because of backlight.

[b] Subject becomes bright with backlight compensation.

After shooting

Be sure to release this adjustment condition by pressing BACK LIGHT again. The  indicator disappears. Otherwise, the picture will be too bright under normal lighting condition.

This function is also effective under following conditions:

- On snow e.g. at the ski resort
- At the beach under strong sunshine
- A subject with a light source nearby or a mirror reflecting light
- A white subject against a white background.

Especially when you shoot a person wearing shiny clothes made of silk or synthetic fiber, his or her face tends to become dark if you do not use this function.

Using the PROGRAM AE function

You can select from three PROGRAM AE (Auto Exposure) modes to suit your shooting situation. When you use PROGRAM AE, you can capture high-speed action or night views.

Selecting the best mode

Select the best mode by using the following examples.



Sports mode

- Outdoor sports scenes such as football, tennis, golf or skiing
- A landscape in a moving car

High-speed shutter mode

- A golf swing or a tennis match in fine weather with the ball captured clearly
- Playing back certain scenes with high-speed movements in clear, sharp picture

Twilight mode

- Recording night views, neon signs or fireworks

Using the PROGRAM AE function

Set the mark of the desired mode to the ▼ mark above the PROGRAM AE dial.

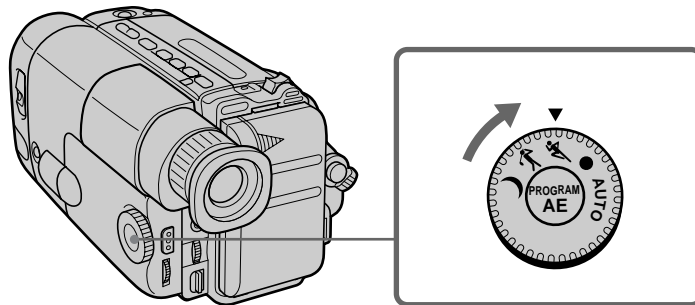

To return to automatic mode

Turn the PROGRAM AE dial so that the ▼ mark points to AUTO.

Note on shutter speed

The shutter speed in each PROGRAM AE mode is as follows:

Sports mode – between 1/60 to 1/500

High-speed shutter mode – 1/4000

Twilight mode – 1/60

AUTO mode – 1/60 (or 1/100 when the Steady Shot is on – CCD-TRV21/TRV29/TRV211 only)

Selecting the START/STOP mode

Your camcorder has two modes besides normal start/stop mode. These modes enable you to take a series of quick shots resulting in a lively video.

(1) While pressing PUSH OPEN, open the LCD panel.

(2) Set START/STOP MODE to the desired mode.

 : Recording starts when you press START/STOP, and stops when you press it again (normal mode).

 : The camcorder records only while you press down START/STOP.

5 SEC : When you press START/STOP, the camcorder records for 5 seconds and then stops automatically.

(3) Turn STANDBY up and press START/STOP. Recording starts.

If you selected 5 SEC, five dots appear in the viewfinder. The dots disappear at a rate of one per second. When five seconds elapse and all the dots disappear, the camcorder switches to Standby mode automatically.

If you selected  , the camcorder records as long as you hold down START/STOP.

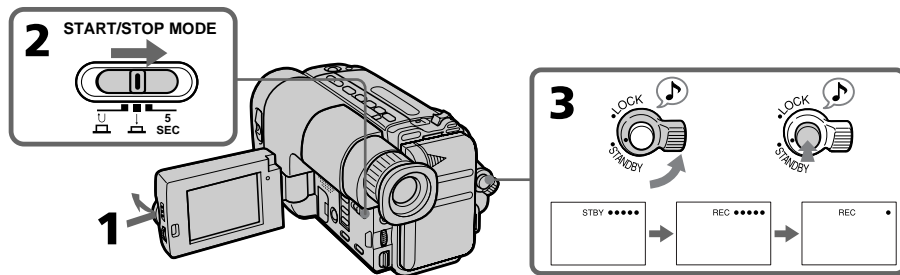

To extend the recording time in 5 SEC mode

Press START/STOP again before all the dots disappear. Recording continues for about 5 seconds from the moment you press START/STOP.

Note on 5 SEC recording

If you have turned off the indicators on the LCD screen, the dots do not appear.

Superimposing a title

You can select from nine preset titles to superimpose it on the picture during recording. Each time you press TITLE, the preset titles appear one by one.

To superimpose from the beginning

- (1) Set the POWER switch to CAMERA.
- (2) Turn STANDBY up.
- (3) While pressing PUSH OPEN, open the LCD panel.
- (4) Press TITLE repeatedly until the desired title appears. The title flashes.
- (5) Press START/STOP to start recording.
- (6) Press TITLE when you want to turn off the title.

To superimpose on the way of recording

- (1) Press TITLE repeatedly until the desired title appears. The title flashes.
- (2) When the title stops flashing, press TITLE. The title disappears.
- (3) Press START/STOP to start recording.
- (4) Press TITLE when you want superimpose the title.
- (5) Press TITLE when you want to turn off the title.

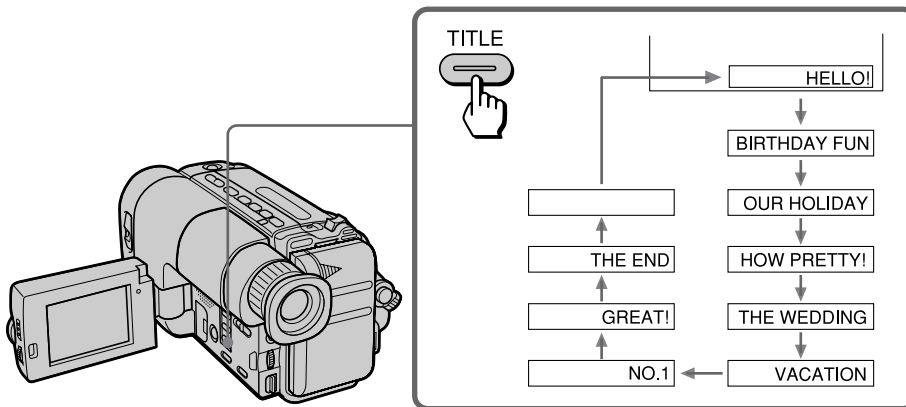

Note on selecting a title

You cannot select a title during recording.

Using the STEADY SHOT function

– CCD-TRV21/TRV29/TRV211 only

You can use the Steady Shot to compensate for camera-shake. Do not use the Steady Shot when shooting a stationary object with a tripod.

- (1) While pressing PUSH OPEN, open the LCD panel.
- (2) Set STEADY SHOT to ON.

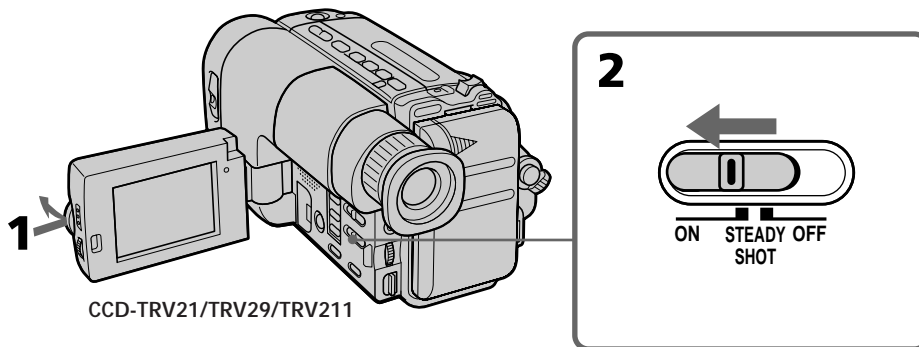

Notes on the steady shot

- The Steady Shot will not correct excessive camera-shake.
- When you switch the Steady Shot on or off, the exposure may fluctuate.

Changing the mode settings

You can change the mode settings to further enjoy the features and functions.

- (1) While pressing PUSH OPEN, open the LCD panel. You will find the mode switches.
- (2) Set the mode switches to the desired mode.

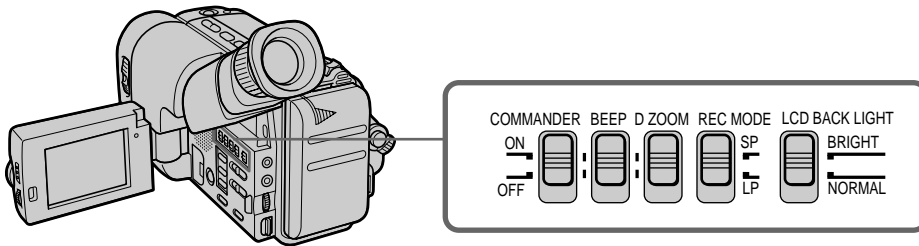

CCD-TRV21/TRV29/TRV211

Selecting the mode setting of each item

COMMANDER <ON/OFF>

- Set to ON when using the supplied Remote Commander for the camcorder.
- Set to OFF when not using the Remote Commander.

BEEP <ON/OFF>

- Set to ON so that beeps sound when you start/stop recording, etc.
- Set to OFF when you do not want to hear the beep sound.

D ZOOM <ON/OFF> -CCD-TRV21/TRV29/TRV211 only

- Select ON to activate digital zooming.
- Select OFF to not use the digital zoom.
The camcorder goes back to 12x zoom.

REC MODE <SP/LP>

- Select SP to record a tape in SP (standard play) mode.
- Select LP to record a tape in LP (long play) mode.

LCD BACK LIGHT <BRIGHT/NORMAL>

- Select BRIGHT to make the LCD screen brighter when shooting/playing back outdoors.
- Normally select NORMAL. The battery life becomes about 10% longer than it is when you select BRIGHT.

Watching on a TV screen

You can use this camcorder as a VCR by connecting it to your TV for playback. When monitoring the playback picture by connecting the camcorder to your TV, we recommend you to use the house current for the power source.

While playing back on a TV screen, close the LCD panel. Otherwise, picture distortion may occur.

Connecting directly to a VCR / TV with Video / Audio input jacks

If your TV is already connected to a VCR

Open the jack cover and connect the camcorder to the LINE IN inputs on the VCR by using the supplied A/V connecting cable. Set the input selector on the VCR to LINE. Set the TV/VCR selector on the TV to VCR.

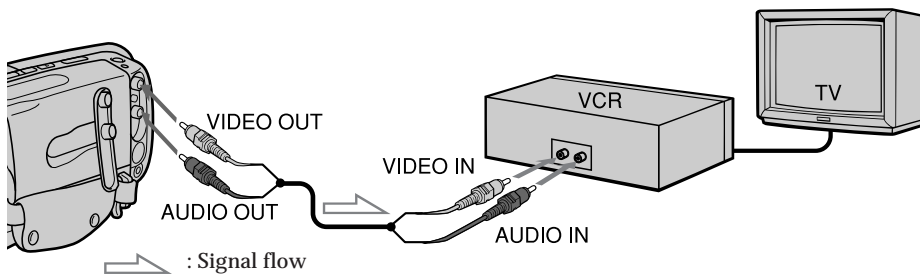

If you connect directly to TV

Connect the camcorder to the inputs on the TV by using the supplied A/V connecting cable. Set the TV/VCR selector on the TV to VCR.

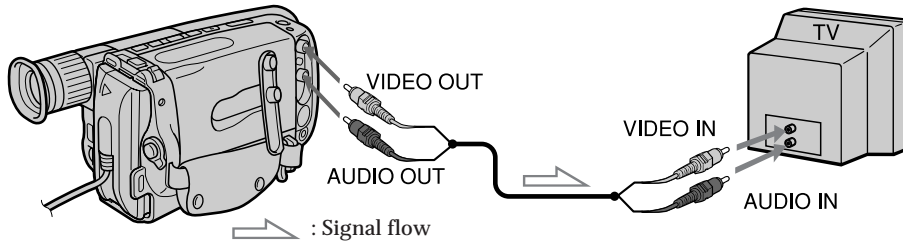

To connect to a VCR or TV without Video/Audio input jacks

Use an RFU adaptor (not supplied).

Editing onto another tape

You can create your own video program by editing with any other **8** 8 mm, **Hi8** Hi8, **VHS** VHS, **S-VHS** S-VHS, **VHS-C** VHSC, **S-VHS-C** S-VHSC, **β** Betamax or **ED Beta** ED Betamax VCR that has video/audio inputs.

Turn down the volume of the camcorder while editing. Otherwise, picture distortion may occur.

After connecting the camcorder to the VCR,

- (1) Set the POWER switch to **PLAYER**.
- (2) Insert a blank tape (or a tape you want to record over) into the VCR and insert your recorded tape into the camcorder.
- (3) Play back the recorded tape on the camcorder until you locate the point where you want to start editing, then press **II** to put the camcorder in playback pause mode.
- (4) On the VCR, locate the recording start point and put the VCR in recording pause mode.
- (5) Press **II** on the camcorder and VCR simultaneously to start editing.

To edit more scenes

Repeat steps 3 to 5.

To stop editing

Press **■** on both the camcorder and VCR.

Additional Information

Changing the lithium battery in the camcorder

Your camcorder is supplied with a lithium battery installed. When the battery becomes weak or dead, the  indicator flashes in the viewfinder or on the LCD screen for about 5 seconds when you set the POWER switch to CAMERA. In this case, replace the battery with a Sony CR2025 or Duracell DL-2025 lithium battery. Use of any other battery may present a risk of fire or explosion.

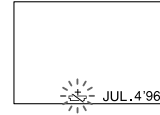

The lithium battery for the camcorder lasts for about 1 year under normal operation. (The lithium battery that comes installed at the factory may not last 1 year.)

Note on lithium battery

Note that the lithium battery has a positive (+) and a negative (-) terminals as illustrated. Be sure to install the lithium battery so that terminals on the battery match the terminals on the camcorder.

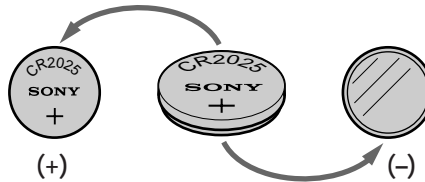

WARNING

The battery may explode if mistreated. Do not recharge, disassemble, or dispose of in fire.

Caution

Keep the lithium battery out of the reach of children. Should the battery be swallowed, consult a doctor immediately.

Changing the lithium battery in the camcorder

Changing the lithium battery

When replacing the lithium battery, keep the battery pack or other power source attached. Otherwise, you will need to reset the date and time.

- (1) Open the lid of the lithium battery compartment.
- (2) Push the battery in once and pull it out from the holder.
- (3) Install the new lithium battery with the positive (+) side facing out.
- (4) Close the lid.

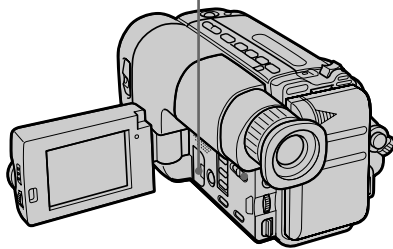
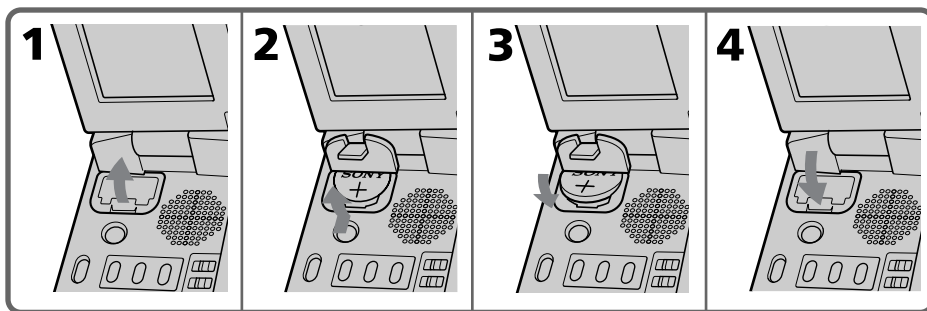

Resetting the date and time

Reset the date and time using the DATE(+) and TIME(NEXT) buttons.

- (1) Set the POWER switch to CAMERA.
- (2) Turn STANDBY up.
- (3) While pressing PUSH OPEN, open the LCD panel.
- (4) Press DATE(+) and TIME(NEXT) simultaneously until the year indicator flashes on the LCD screen or in the viewfinder.
- (5) Set year, month, day, time, minute by pressing DATE(+) and TIME(NEXT).
Note that when you keep DATE(+) pressed, the digits advance faster.

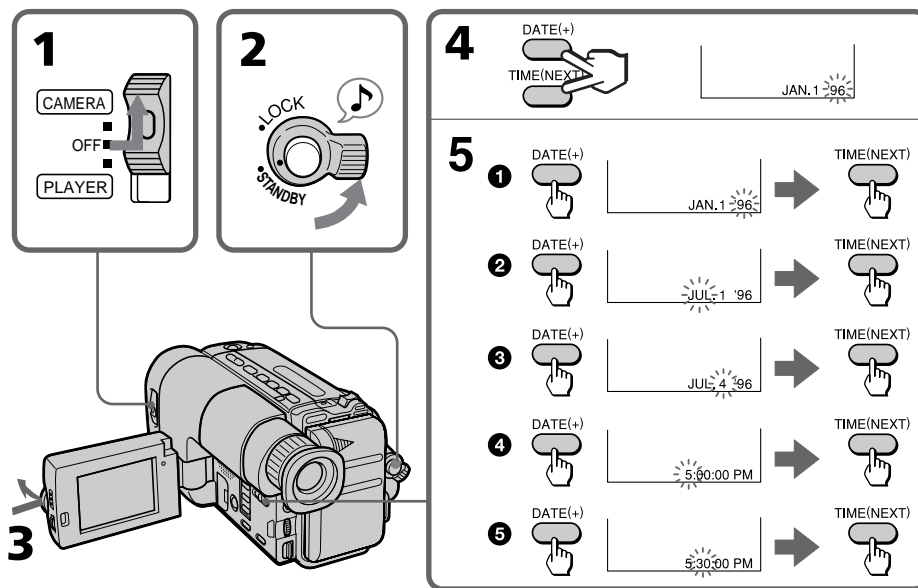

Additional Information

To correct the date and time setting

Repeat steps 4 and 5.

To check the date and time

Press DATE(+) to display the date indicator. Press TIME(NEXT) to display the time indicator. When you press the same button again, the indicator goes out.

The year indicator changes as follows:

'96 → '97 → '25

Note on the time indicator

The internal clock of the camcorder operates on a 12-hour cycle.

12:00:00 AM stands for midnight.

12:00:00 PM stands for noon.

Playback modes

The playback mode (SP/LP) is selected automatically according to the recording system in which the tape has been recorded. The quality of the recorded picture in LP mode, however, will not be as good as that in SP mode.

Recording mode

When you play back a tape recorded in LP mode, the LP indicator lights up in the viewfinder or on the LCD screen.

Foreign 8 mm video

You cannot play back tapes recorded on a different TV color system. Because the TV color systems differ from country to country, you may not be able to play back foreign prerecorded tapes. Refer to the list of "Using your camcorder abroad" to check the TV color system of foreign countries.

Tips for using the battery pack

This section shows you how you can get the most out of your battery pack.

Preparing the battery pack

Always carry additional batteries

Have sufficient battery pack power to do 2 to 3 times as much recording as you have planned.

Battery life is shorter in cold environment

Battery efficiency is decreased, and the battery will be used up more quickly, if you are recording in cold environment.

To save battery power

Turn the STANDBY switch on the camcorder down when not recording to save battery power.

A smooth transition between scenes can be made even if recording is stopped and started again. While positioning the subject, selecting an angle, or looking through the viewfinder lens or on the LCD screen, the lens moves automatically and the battery is used. The battery is also used when a cassette is inserted or removed.

Tips for using the battery pack

When to replace the battery

While you are using your camcorder, the remaining battery indicator in the viewfinder or on the LCD screen decreases gradually as battery power is used up.



When the remaining battery indicator reaches the lowest point, the  indicator appears and starts flashing in the viewfinder or on the LCD screen.

When the  indicator in the viewfinder or on the LCD screen changes from slow flashing to rapid flashing while you are recording, set the POWER switch to OFF on the camcorder and replace the battery pack. Leave the tape in the camcorder to obtain smooth transition between scenes after the battery pack has been replaced.

Note on the remaining battery indicator

The remaining battery indicator of the camcorder may indicate a different remaining capacity from that of the battery pack with its own indicator (not supplied). The indicator on the battery pack is more accurate.

Notes on the rechargeable battery pack

CAUTION

Never leave the battery pack in temperatures above 140°F (60°C), such as in a car parked in the sun or under direct sunlight.

The battery heats up

During charging or recording, the battery pack heats up. This is caused by energy that has been generated and a chemical change that has occurred inside the battery pack. This is not cause for concern and is normal.

Battery pack care

- Remove the battery pack from the camcorder after using it, and keep it in a cool place. When the battery pack is installed to the camcorder, a small amount of current flows to the camcorder even if the POWER switch is set to OFF. This shortens battery life.
- The battery pack is always discharging even when it is not in use after charging. Therefore, you should charge the battery right before using the camcorder.

How to use the switch on the battery pack

When the switch is supplied with the battery pack (**[a]** on page 36), you can use it to find whether the battery pack is charged or not. Set the switch to the “no mark” position when charging is completed. Set the switch to the “red mark” position when the battery is used up (or in whichever direction you want to remind yourself).

The life of the battery pack

If the battery indicator flashes rapidly just after turning on the camcorder with a fully charged battery pack, the battery pack should be replaced with a new fully charged one.

Charging temperature

You should charge batteries at temperatures from 50°F to 86°F (from 10°C to 30°C). Lower temperatures require a longer charging time.

Sony Batteries are Recommended

Use of non-Sony batteries may damage your Handycam camcorder.

Tips for using the battery pack

Notes on charging

A brand-new battery

A brand-new battery pack is not charged. Before using the battery pack, charge it completely.

After long storage

Recharge the battery pack after a long period of storage. If the battery pack is charged fully but not used for a long time (about 1 year), it becomes discharged. Charge it again, but in this case the battery life will be shorter than normal. After several charging and discharging cycles, the battery life will recover its original capacity.

Notes on the terminals

If the terminals (metal parts on the back) are not clean, the battery charge duration will be shortened.

When the terminals are not clean or when the battery pack has not been used for a long time, repeatedly install and remove the battery pack a few times. This improves the contact condition. Also, wipe the + and - terminals with a soft cloth or paper.

Be Sure to Observe the Following

- To prevent an accident caused by a short circuit, do not allow metal objects such as a necklace to touch the battery terminals. When carrying the battery pack, attach to the terminal cover. [b]
- Keep the battery pack away from fire.
- Keep the battery pack dry.
- Do not open nor try to disassemble the battery pack.
- Do not expose the battery pack to any mechanical shock.

[a]



[b]

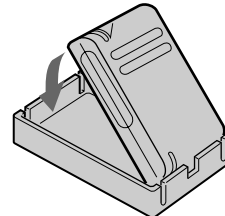

Notes on the Battery Case

– CCD-TRV11/TRV19/TRV21/TRV29 only

- Use only with alkaline batteries. You cannot use the battery case with manganese batteries or size AA rechargeable NiCd batteries.
- Battery life is remarkably shorter in a cold environment (lower than 50°F/10°C).
- Keep the metal part clean. If it gets dirty, wipe it with a soft cloth.
- Do not disassemble or convert the battery case.
- Do not expose the battery case to any mechanical shock.
- During recording, the battery case heats up. This is not cause for concern.
- Prevent the electrode in the battery case from coming in contact with a metal object.
- If you will not use the battery case for a long time, detach the battery case from the camcorder and remove the batteries from the battery case.

Notes on Alkaline Batteries

To avoid possible damage from battery leakage or corrosion, observe the following.

- Be sure to insert the batteries in the correct direction.
- Alkaline batteries are not rechargeable.
- Do not use a combination of new and old batteries.
- Do not use different types of batteries.
- The batteries slowly discharge while not in use.
- Do not use a battery that is leaking.

If battery leakage occurred



- Wipe off the liquid in the battery case carefully before replacing the batteries.
- If you touch the liquid, wash it off with water.
- If the liquid get into your eyes, wash your eyes with a lot of water and then consult a doctor.

Maintenance information and precautions

Moisture condensation

If the camcorder is brought directly from a cold place to a warm place, moisture may condense inside the camcorder, on the surface of the tape, or on the lens. In this condition, the tape may stick to the head drum and be damaged or the unit may not operate correctly. To prevent possible damage under these circumstances, the camcorder is furnished with moisture sensors. Please take the following precautions.

Inside the camcorder

When the  and  indicators flash in the viewfinder or on the LCD screen, moisture has condensed inside the camcorder. If this happens, no other functions except for tape ejection will work.

Eject the tape, turn off the camcorder and leave it with the cassette compartment open for at least one hour. The camcorder can be used again if the  indicator does not appear when the power is turned on again.

On the lens

If moisture condenses on the lens, no indicator appears, but the picture becomes dim. Turn off the power and do not use the camcorder for about 1 hour.

How to prevent moisture condensation

When bringing the camcorder from a cold place to a warm place, put the camcorder in a plastic bag and allow it to adapt to room conditions over a period of time.

- (1) Be sure to tightly seal the plastic bag containing the camcorder.
- (2) Remove the bag when the air temperature inside it has reached the temperature surrounding it (after about 1 hour).

Video head cleaning

To ensure normal recording and clear pictures, clean the video heads. When  appears in the viewfinder or on the LCD screen in CAMERA mode or playback pictures are “noisy” or hardly visible, the video heads may be dirty.



[a] Slight dirty

[b] Dirty

If this happens, clean the video heads with the Sony V8-25CLH cleaning cassette (not supplied). After checking the picture, if it is still “noisy”, repeat the cleaning. (Do not repeat cleaning more than 5 times in one session.)

Caution

Do not use a commercially available wet-type cleaning cassette. It may damage the video heads.

Note

If the V8-25CLH cleaning cassette is not available in your area, consult your nearest Sony dealer.

Removing dust from inside the viewfinder

- (1) Remove the screw with a screwdriver (not supplied). Then, while sliding the RELEASE knob, turn the eyecup in the direction of the arrow and pull it out.
- (2) Clean the surface with a commercially available blower.

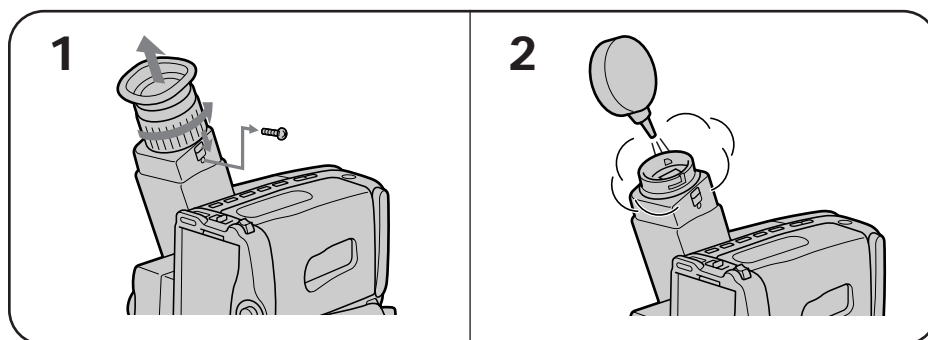

To reattach the eyecup

- (1) Align the groove on the eyecup with the • mark on the barrel.
- (2) Turn the eyecup in the direction of the arrow. Then, replace the screw.

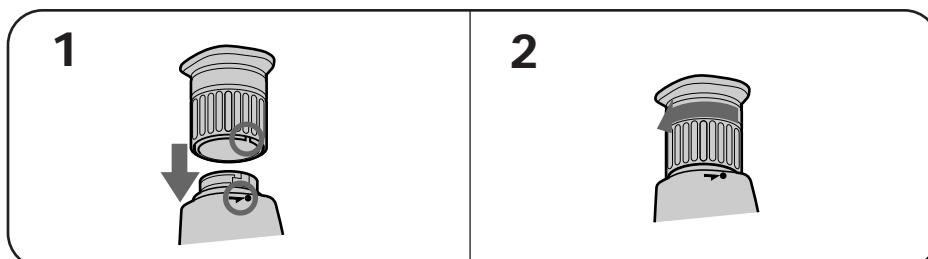

Caution

Do not remove any other screws. You may remove only the screws to remove the eyecup.

Maintenance information and precautions

Precautions

Camcorder operation

- Operate the camcorder using 6.0 V (battery pack), or 7.5 V (AC power adaptor).
- Should any solid object or liquid fall into the casing, unplug the camcorder and have it checked by your nearest Sony dealer before operating it any further.
- Avoid rough handling or mechanical shock. Be particularly careful of the lens.
- Keep the POWER switch set to OFF when not using the camcorder.
- Do not wrap up the camcorder and operate it since heat may build up internally.
- Keep the camcorder away from strong magnetic fields or mechanical vibration.
- Do not push the LCD screen.
- If the camcorder is used in a cold place, a residual image may appear on the LCD screen.
This is not a malfunction.
- While using the camcorder, the back of the LCD screen may heat up. This is not a malfunction.

On handling tapes

Do not insert anything in the small holes on the rear of the cassette. These holes are used to sense the type of tape, thickness of tape, and if the recording tab is out or in.

Camcorder care

- When the camcorder is not to be used for a long time, disconnect the power source and remove the cassette. Periodically turn on the power, operate the camera and player sections and play back a tape for about 3 minutes.
- Clean the lens with a soft brush to remove dust. If there are fingerprints on the lens, remove them with a soft cloth.
- Clean the camcorder body with a soft dry cloth, or a soft cloth lightly moistened with a mild detergent solution. Do not use any type of solvent which may damage the finish.

AC power adaptor

Charging

- Attach the battery pack firmly.
- Place the battery pack on a flat surface without vibration during charging.

Others

- Unplug the unit from the wall outlet when not in use for a long time. To disconnect the power cord, pull it out by the plug. Never pull the cord itself.
- Do not operate the unit with a damaged cord or if the unit has been dropped or damaged.
- Do not bend the AC power cord forcibly, or put a heavy object on it. This will damage the cord and may cause a fire or an electrical shock.
- Be sure that nothing metallic comes into contact with the metal parts of the connecting plate. If this happens, a short may occur and the unit may be damaged.
- Always keep the metal contacts clean.
- Do not disassemble the unit.
- Do not apply mechanical shock or drop the unit.
- While the unit is in use, particularly during charging, keep it away from AM receivers and video equipment because it will disturb AM reception and video operation.
- The unit becomes warm while in use. This is normal.
- Do not place the unit in locations that are:
 - Extremely hot or cold
 - Dusty or dirty
 - Very humid
 - Vibrating

If any difficulty should arise, unplug the unit and contact your nearest Sony dealer.

Using your camcorder abroad

Each country or area has its own electricity and TV color systems. Before using your camcorder abroad, check the following points:

Power sources

You can use your camcorder in any country or area with the supplied AC power adaptor within 110 V to 240 V AC, 50/60 Hz. Use a commercially available AC plug adaptor [a], if necessary, depending on the design of the wall outlet [b].

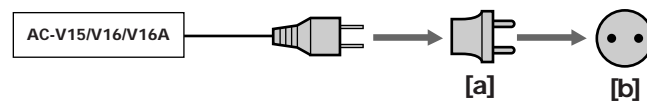

Difference in color systems

This camcorder is an NTSC system-based camcorder. If you want to view the playback picture on a TV, it must be an NTSC system based TV or a PAL M system-based TV with an NTSC/PAL M transcoder. Check the following list.

NTSC system

Bahama Islands, Bolivia, Canada, Central America, Chile, Colombia, Ecuador, Jamaica, Japan, Korea, Mexico, Peru, Surinam, Taiwan, the Philippines, the U.S.A., Venezuela, etc.

PAL system

Australia, Austria, Belgium, China, Denmark, Finland, Germany, Great Britain, Holland, Hong Kong, Italy, Kuwait, Malaysia, New Zealand, Norway, Portugal, Singapore, Spain, Sweden, Switzerland, Thailand, etc.

PAL M system

Brazil

PAL N system

Argentina, Paraguay, Uruguay

SECAM system

Bulgaria, Czech Republic, France, Guyana, Hungary, Iran, Iraq, Monaco, Poland, Russia, Slovak Republic, Ukraine, etc.

Trouble check

If you run into any problem using the camcorder, use the following table to troubleshoot the problem.
Should the difficulty persist, disconnect the power source and contact your Sony dealer or local authorized Sony service facility.

Camcorder

Power

Symptom	Cause and/or Corrective Actions
The power is not on.	<ul style="list-style-type: none"> • The battery pack is not installed. → Attach the battery pack firmly by pushing the lower part of the battery pack. (p. 7) • The battery is dead. → Use a charged battery pack. (p. 6) • The AC power adaptor is not connected to wall outlet. → Connect the AC power adaptor to wall outlet. (p. 19)
The power goes off.	<ul style="list-style-type: none"> • While being operated in CAMERA mode, the camcorder has been in the Standby mode for more than 5 minutes. → Turn STANDBY down once and turn it up again. (p. 10) • The battery is dead. → Use a charged battery pack. (p. 6)
The battery pack is quickly discharged.	<ul style="list-style-type: none"> • The ambient temperature is too low. (p. 34) • The battery pack has not been charged fully. → Charge the battery pack again. (p. 6) • The battery pack is completely dead, and cannot be recharged. → Use another battery pack. (p. 35)

Operation

Symptom	Cause and/or Corrective Actions
START/STOP does not operate.	<ul style="list-style-type: none"> • The tape is stuck to the drum. → Eject the cassette. (p. 8) • The tape has run out. → Rewind the tape or use a new one. (p. 16) • The POWER switch is set to PLAYER. → Set it to CAMERA. (p. 9) • The tab on the cassette is out (red). → Use a new cassette or slide the tab. (p. 8)
The cassette cannot be removed from the holder.	<ul style="list-style-type: none"> • The battery is dead. → Use a charged battery pack or the AC power adaptor. (p. 7, 19)
No function except for cassette ejection works.	<ul style="list-style-type: none"> • Moisture condensation has occurred. → Remove the cassette and leave the camcorder for at least 1 hour. (p. 38)
The tape does not move when a tape transport button is pressed.	<ul style="list-style-type: none"> • The POWER switch is set to CAMERA or OFF. → Set it to PLAYER. (p. 16) • The tape has run out. → Rewind the tape or use a new one. (p. 16)
The date or time indicator is flashing.	<ul style="list-style-type: none"> • You pressed DATE and TIME together for more than 2 seconds. The camcorder is not malfunctioning. → You may start recording. Flashing will stop soon. • The lithium battery is weak or dead. → Replace the lithium battery with a new one. (p. 31)

(to be continued)

Trouble check

Symptom	Cause and/or Corrective Actions
The date or time indicator disappears.	<ul style="list-style-type: none"> Reset the date and time. (p. 33)
Recording stops in a few seconds.	<ul style="list-style-type: none"> START/STOP MODE switch is set to $\frac{1}{2}$ or 5 SEC. → Set it to $\frac{1}{4}$. (p. 25)
Picture	
Symptom	Cause and/or Corrective Actions
The image on the viewfinder screen is not clear.	<ul style="list-style-type: none"> The viewfinder lens is not adjusted. → Adjust the viewfinder lens. (p. 10)
A vertical band appears when a subject such as lights or a candle flame is shot against a dark background.	<ul style="list-style-type: none"> The contrast between the subject and background is too high. The camcorder is not malfunctioning. → Change locations.
The picture is "noisy".	<ul style="list-style-type: none"> The video heads may be dirty. → Clean the heads using the Sony V8-25CLH cleaning cassette. (p. 38)
The picture does not appear in the viewfinder.	<ul style="list-style-type: none"> The LCD panel is open. → Close the LCD panel. (p. 12)
The picture does not appear on the LCD screen.	<ul style="list-style-type: none"> Incorporated fluorescent tube is worn out. → Please contact your nearest Sony dealer.
A vertical band appears when shooting a very bright subject.	<ul style="list-style-type: none"> The camcorder is not malfunctioning.
An unknown picture is displayed.	<ul style="list-style-type: none"> The camcorder operates in Demo mode. → Exit the Demo mode. (p. 53)
Others	
Symptom	Cause and/or Corrective Actions
The supplied Remote Commander does not work .	<ul style="list-style-type: none"> COMMANDER is set to OFF. → Set it to ON. (p. 28) Something is blocking the infrared rays. → Remove the obstacle. The battery is not inserted with the correct polarity. → Insert the battery with the correct polarity. (p. 52) The batteries are dead. → Insert new ones. (p. 52)
There is dust in the viewfinder	<ul style="list-style-type: none"> Detach the eyecup and clean the viewfinder lens. (p. 39)
Bubbles appear inside the lens.	<ul style="list-style-type: none"> When you use the camcorder where the air pressure is low such as on a mountain or in an airplane, you may find bubbles inside the lens. This is not a malfunction. Bubbles will usually disappear after about a week. But, how long it takes depends on the air pressure and use.

AC power adaptor

Symptom	Cause and/or Corrective Actions
The POWER lamp does not light.	<ul style="list-style-type: none"> Set the selector to VTR (DC OUT) and disconnect the power cord. After about one minute, try again. (p. 7)
The CHARGE lamp flashes.	<ul style="list-style-type: none"> See the following chart.

When the CHARGE lamp flashes

Check through the following chart.

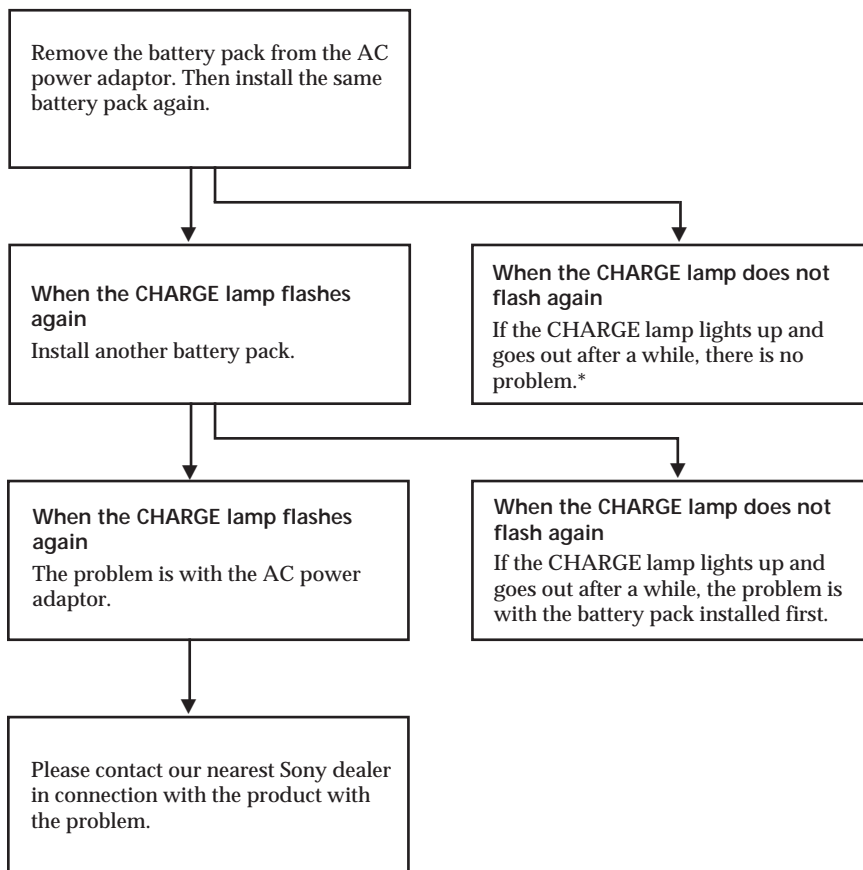

* If you use a battery pack which you have just bought or which has been left unused for a long time, the CHARGE lamp may flash at the first charging. This does not indicate a problem. Repeat again to charge with the same battery pack.

Specifications

Video camera recorder

System

Video recording system
Two rotary heads, Helical scanning, FM system

Audio recording system
Rotary heads, FM system

Video signal
NTSC color, EIA standards

Usable cassette
8 mm video format cassette (standard 8 mm)

Recording/Playback time
SP mode: 2 hours (P6-120)
LP mode: 4 hours (P6-120)

Fastforward/rewind time
Approx. 5 min. (P6-120)

Image device
CCD (Charge Coupled Device)

Viewfinder
Electronic viewfinder
CCD-TRV11/TRV21/
TRV211:Black and white
CCD-TRV19/TRV29/
TRV119:Color

Lens
Combined power zoom lens, F1.8-2.7

Filter diameter 1 1/2 inches (37 mm)
CCD-TRV11/TRV19/TRV119:
12x (Optical)

CCD-TRV21/TRV29/TRV211:
12x (Optical), 24x (Digital)

Focal distance
 $f = \frac{1}{32} - 2 \frac{3}{4}$ inches (5.4 - 64.8 mm)
When converted to a 35mm still camera

CCD-TRV11/TRV19/TRV119:
1 9/16 - 18 1/2 inches (39 - 468mm)

CCD-TRV21/TRV29/TRV211:
1 7/8 - 22 1/4 inches (47 - 564 mm)

Color temperature
Auto

Minimum illumination*
CCD-TRV11/TRV19/TRV119:
0.8 lx at F 1.8

CCD-TRV21/TRV29/TRV211:
3 lx at F 1.8

Illumination range
CCD-TRV11/TRV19/TRV119:
0.8 to 100,000 lx

CCD-TRV21/TRV29/TRV211:
4 to 100,000 lx

Recommended illumination
More than 100 lx

* Minimum illumination expresses the light level a camcorder requires to produce a picture.

LCD screen
Picture
2.5 inches measured diagonally
2 x 1 1/2 inches (50.3 x 37.4 mm)

On-screen display
TN LCD/TFT active matrix method

Total dot number
61,380 (279 x 220)

Input and Output connectors
Video output

Phono jack, 1 Vp-p, 75 Ω , unbalanced

Audio output
Monaural, Phono jack, 327 mV, (at load impedance 47 k Ω), impedance less than 2.2 k Ω

RFU DC OUT
Special minijack, DC 5 V

Earphone jack
Mini-jack

LANC control jack
Stereo mini-minijack (ϕ 2.5 mm)

MIC jack
Minijack, 0.388 mV, low impedance with 2.5 to 3 V DC output, impedance 6.8 k Ω (ϕ 3.5 mm)

Speaker
Dynamic-speaker

General

Power requirements
7.5 V (AC power adaptor)

Average power consumption
During camera recording using the LCD
CCD-TRV11/TRV19/TRV119:
4.7W

CCD-TRV21/TRV29/TRV211:
5.1W

During camera recording using the viewfinder

CCD-TRV11/TRV19/TRV119:
3.6W

CCD-TRV21/TRV29/TRV211:
4.0W

Operating temperature
32°F to 104°F (0°C to 40°C)

Storage temperature
-4°F to +140°F (-20°C to +60°C)

Dimensions (Approx.)
4 1/2 x 4 1/4 x 8 3/8 inches
(113 x 106 x 210 mm) (w/h/d)

Mass (Approx.)

CCD-TRV11/TRV19/TRV119: 1 lb 13 oz (850g)

CCD-TRV21/TRV29/TRV211: 1 lb 14 oz (860g)

Excluding the battery pack, lithium battery, cassette and shoulder strap
2 lb 6 oz (1.1kg)

Including the battery pack NP-33, lithium battery CR2025, cassette P6-120 and shoulder strap

Microphone
Electret condenser microphone, monaural type

Supplied accessories
See page 5.

AC power adaptor

Power requirements
110 - 240 V AC, 50/60Hz

Power consumption
AC-V15: 18 W

AC-V16: 20 W
AC-V16A: 22 W

Output voltage
DC OUT in operation mode

AC-V15: 7.5 V, 1.6 A
AC-V16/V16A: 7.5 V, 1.8 A

Battery charge terminal
10 V, 1.1 A in charge mode

Application

Sony battery packs NP-33(supplied), NP-55, NP-60D, NP-C65, NP-66, NP-66H, NP-68, NP-80, NP-80D, NP-98, NP-98D

Operating temperature
32°F to 104°F (0°C to 40°C)

Storage temperature
-4°F to +140°F (-20°C to +60°C)

Dimensions (Approx.)
6 5/8 x 1 1/16 x 3 inches (166 x 43 x 75 mm) (w/h/d)

including projecting parts and controls

Mass (Approx.)
AC-V15/V16: 15 oz (420 g)
AC-V16A: 16 oz (450 g)

Design and specifications are subject to change without notice.



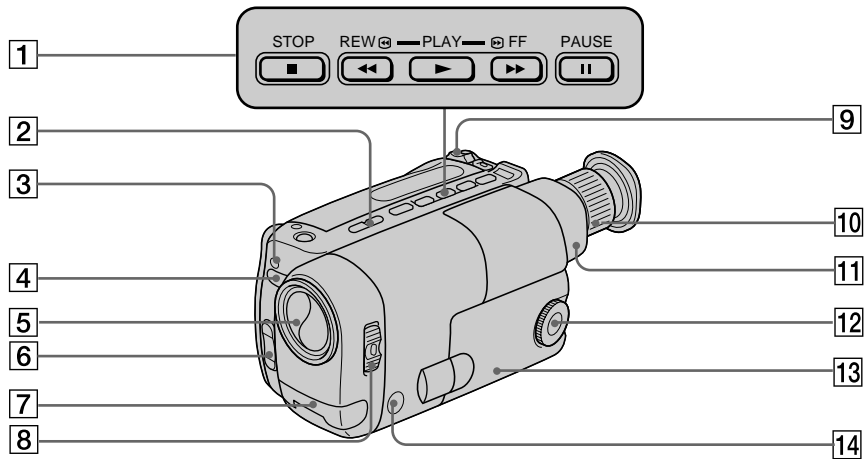

Identifying the parts

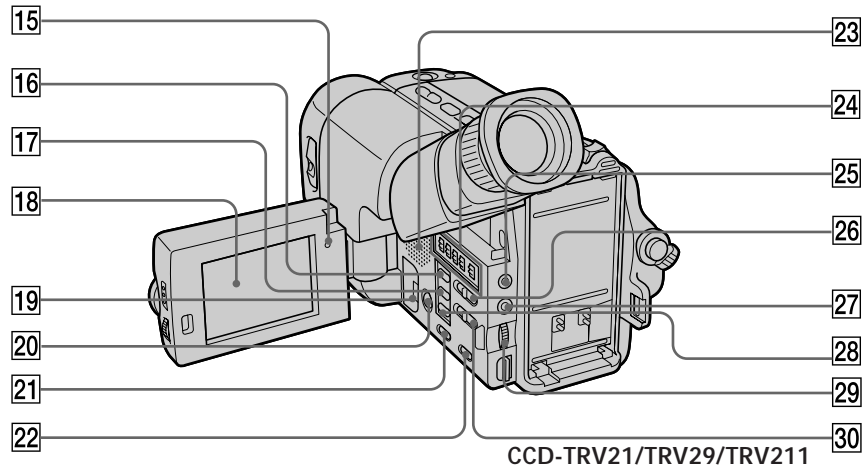

- | | |
|---|---|
| <p>1 Tape transport buttons (p. 16, 17)</p> <ul style="list-style-type: none"> ■ STOP ◀◀ REW (rewind) ▶▶ PLAY (playback) ▶▶ FF (fast forward) PAUSE <p>These buttons will function in PLAYER mode.</p> | <p>7 Built-in microphone</p> |
| <p>2 EDITSEARCH button (p. 15)</p> | <p>8 POWER switch (p. 9, 16)</p> |
| <p>3 Recording lamp</p> | <p>9 Power zoom lever (p. 11)</p> |
| <p>4 Remote sensor (p. 53)</p> <p>Aim the Remote Commander here for remote control.</p> | <p>10 Viewfinder adjustment ring (p. 10)</p> |
| <p>5 Lens cover</p> | <p>11 Viewfinder (p. 10, 39, 54)</p> |
| <p>6 Power zoom button (p. 14)</p> <p>Use this button when recording in a low position.</p> | <p>12 PROGRAM AE dial (p. 24)</p> |
| | <p>13 LCD panel (p. 12)</p> |
| | <p>14 BACK LIGHT button (p. 23)</p> |

Identifying the parts



- 15 Recording lamp
- 16 DATE (+) button (p. 22)
- 17 TIME (NEXT) button (p. 22)
- 18 LCD screen (p. 16, 54)
- 19 Lithium battery compartment (p. 32)
- 20 DISPLAY button (p. 17)
- 21 COUNTER RESET button (p. 11)
- 22 END SEARCH button (p. 18)
- 23 Speaker
- 24 Mode switches (p. 28)
- 25 LANC  control jack
 stands for Local Application Control Bus system. The  control jack is used for controlling the tape transport of video equipment and peripherals connected to it. This jack has the same function as the connectors indicated as CONTROL L or REMOTE.
- 26 START/STOP MODE switch (p. 9, 10, 25)
- 27  (earphone) jack (p. 17)
- 28 TITLE button (p. 26)
- 29 VOL (speaker volume) control (p. 16)
- 30 STEADY SHOT switch (p. 27)
(CCD-TRV21/TRV29/TRV211 only)

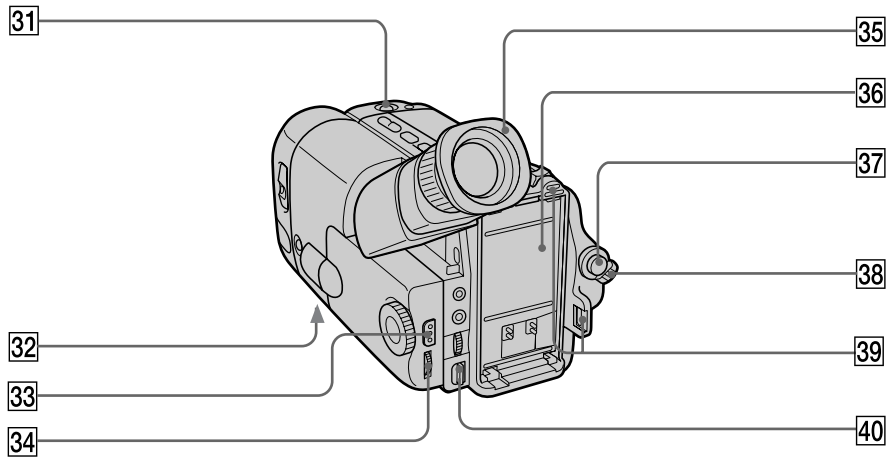

- | | |
|--|---|
| <p>31 START/STOP button (p. 14)
Use this button when recording in a low position.</p> <p>32 Tripod receptacle (p. 14)</p> <p>33 PUSH OPEN button (p. 12, 16)</p> <p>34 LCD BRIGHT dial (p. 12)</p> <p>35 Eyecup (p. 13, 39)</p> | <p>36 Battery mounting surface (p. 7)</p> <p>37 START/STOP button (p. 9)</p> <p>38 STANDBY switch (p. 9)</p> <p>39 Hooks for shoulder strap</p> <p>40 BATT (battery release) knob (p. 8)</p> |
|--|---|

Attaching the shoulder strap

Attach the supplied shoulder strap to the hooks for the shoulder strap.

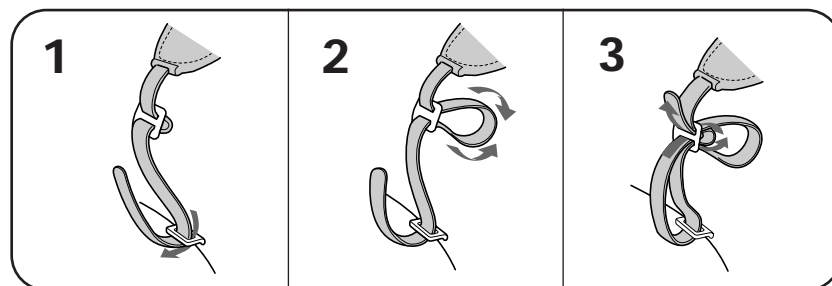

Identifying the parts

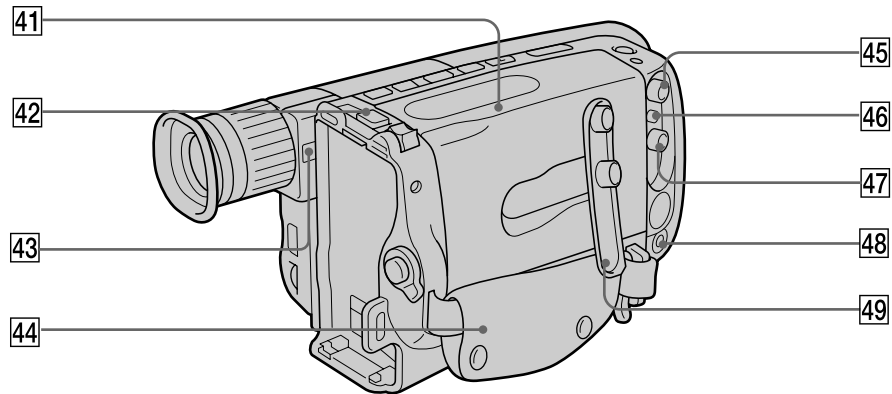

41 Cassette compartment (p. 8)

42 EJECT knob (p. 8)

43 Eyecup release knob (p. 39)

44 Grip strap (p. 13)

45 VIDEO OUT jack (p. 29)

46 RFU DC OUT (RFU adaptor DC out) jack

47 AUDIO OUT jack (p. 29)

48 MIC (microphone) jack
Connect an external microphone (not supplied). This jack also accepts a "plug-in-power" microphone.

49 Jack cover

Remote commander

Using the Remote Commander

Make sure that the COMMANDER mode is set to ON (p. 28).

The buttons that have the same name on the Remote Commander as on the camcorder function identically.

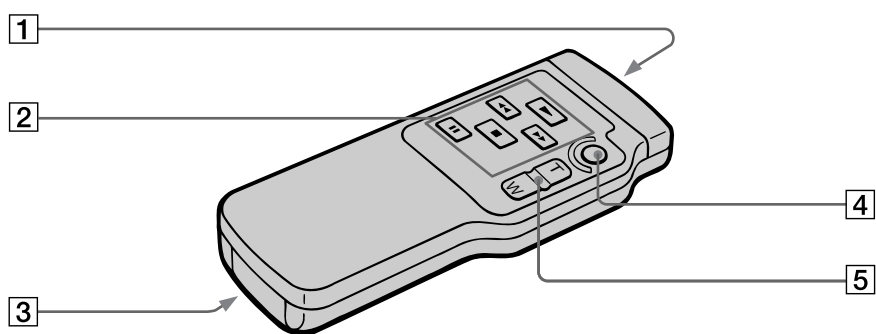

- 1** Transmitter
Point toward the remote sensor to control the camcorder after turning on the camcorder.
- 2** Tape transport buttons (p. 16)
- 3** Size AA (R6) battery holder (p. 52)

- 4** START/STOP button
- 5** Power zoom button
The zooming speed is unchangeable on the Remote Commander.

Identifying the parts

To prepare the remote commander

To use the Remote Commander, you must insert two size AA (R6) batteries. Use the supplied size AA (R6) batteries.

- (1) Remove the battery cover from the Remote Commander.
- (2) Insert both of the size AA (R6) batteries with correct polarity.
- (3) Put the battery cover back onto the Remote Commander.

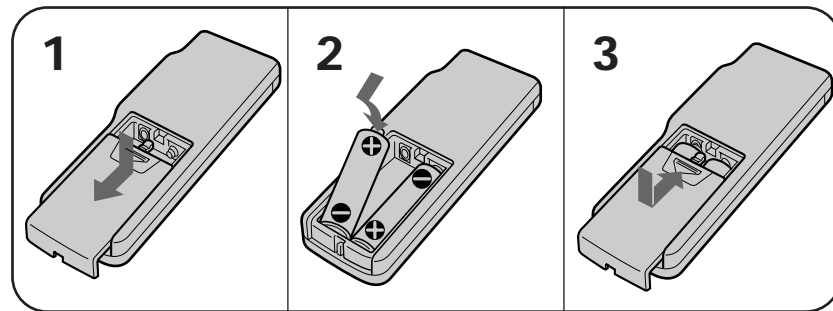

Note on battery life

The batteries for the Remote Commander last about 6 months under normal operation. When the batteries become weak or dead, the Remote Commander does not work.

To avoid damage from possible battery leakage

Remove the batteries when you will not use the Remote Commander for a long time.

Remote control direction

Aim the Remote Commander to the remote sensor within the range as shown below.

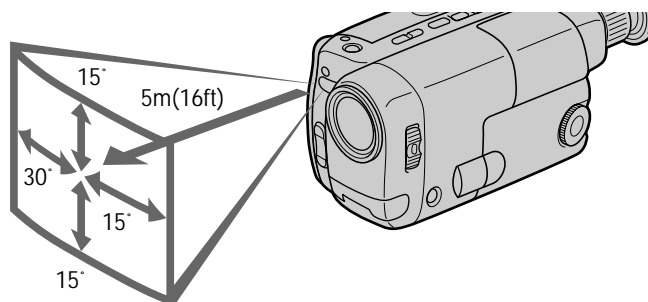

Notes on the Remote Commander

- Keep the remote sensor away from strong light sources such as direct sunlight or illumination. Otherwise, the remote control may not be effective.
- Be sure that there is no obstacle between the remote sensor on the camcorder and the Remote Commander.
- This camcorder works at commander mode VTR 2. The commander modes (1, 2, and 3) are used to distinguish this camcorder from other Sony VCRs to avoid remote control misoperation. If you use another Sony VCR at commander mode VTR 2, we recommend you change the commander mode or cover the remote sensor of the VCR with black paper.

To watch the demonstration

You can watch a brief demonstration of pictures with special effects.

If the demonstration appears when you turn on the camcorder for the first time, exit the Demo mode to use your camcorder.

To enter demo mode

- (1) Eject the cassette and set the POWER switch to OFF.
- (2) Turn STANDBY up.
- (3) While holding down \blacktriangleright set the POWER switch to CAMERA. Demonstration starts. The demonstration stops when you insert the cassette.

Note that once you enter Demo mode, this mode is retained as long as the lithium battery is in place. Therefore, demonstration starts automatically 10 minutes later every time you set the POWER switch to CAMERA, or after you eject the cassette.

To exit demo mode

- (1) Set the POWER switch to OFF.
- (2) Turn STANDBY up.
- (3) While holding down \blacksquare set the POWER switch to CAMERA.

Identifying the parts

In the viewfinder and on the LCD screen

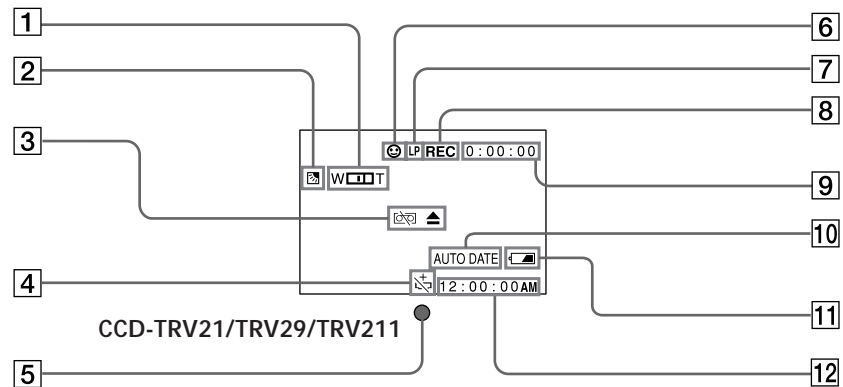

- 1 Power zoom indicator (p. 12)
(CCD-TRV21/TRV29/TRV211 only)
- 2 Back light indicator (p. 23)
- 3 Warning indicator (p. 55)
- 4 Lithium battery indicator (p. 31)
- 5 Recording lamp/battery lamp (p. 9)
(in the viewfinder)
- 6 Mirror mode indicator (p. 21)

- 7 Recording in LP mode (p. 9)
 - 8 Tape transport mode (p. 9)
 - 9 Tape counter (p. 11)
 - 10 AUTO DATE indicator (p. 9)
 - 11 Remaining battery indicator (p. 35)
-
- 12 Date, Time or Title (p. 22, 26)

Warning indicators

If indicators flash in the viewfinder or on the LCD screen, or a caution lamp on the camcorder flashes, check the following:

♪: You can hear the beep sound when BEEP is set to ON (p. 28).

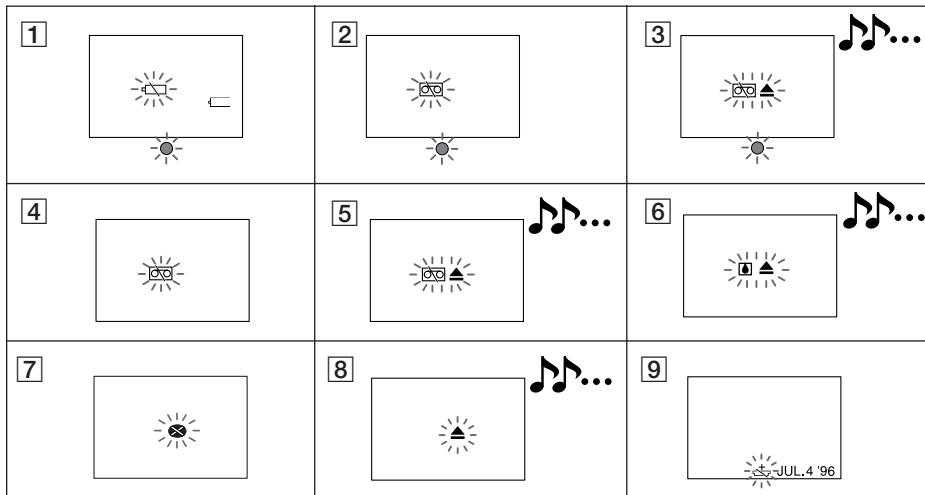

- | | |
|--|--|
| <p>1 The battery is weak or dead.
Slow flashing: The battery is weak.
Fast flashing: The battery is dead.</p> <p>2 The tape is near the end.</p> <p>3 The tape has run out.</p> <p>4 No tape has been inserted.</p> <p>5 The tab on the tape is out (red) (p. 8).</p> <p>6 Moisture condensation has occurred (p. 38).
▲ indicator appears only when the cassette is inserted.</p> | <p>7 The video heads may be contaminated (p. 38).</p> <p>8 Some other trouble has occurred.
Disconnect the power source and contact your Sony dealer or local authorized facility.</p> <p>9 The lithium battery is weak or is not installed (p. 31).
This indicator flashes just only after powering on.</p> |
|--|--|

Index

A

Adjusting viewfinder 10
AUTO DATE 11

B

BACK LIGHT 23
BEEP 11, 28

C

Camera recording 9
Car battery 21
Charging battery 6
Cleaning video heads 38
COUNTER RESET 11

D

DATE/TIME 22
DEMO mode 53

E

Editing 30
EDITSEARCH 15
EJECT 8
END SEARCH 18

F, G, H

Fast-forward 16
5 sec. recording 25
High-speed shutter mode 24
House current 19

I, J, K, L

LANC 48
Lithium battery 31

M, N, O, P

MIC (microphone) jack 50
Playback on TV 16
Playback pause 17
Power sources 19
Power zoom 11
PROGRAM AE 24

Q, R

REC MODE 28
Rec. Review 15
Remote Commander 51
Remote control jack (LANC)
..... 48
Rewind 16

S

Shoulder strap 49
Sports mode 24
STANDBY 9, 10
Standby mode 10
STEADY SHOT 27
Supplied accessories 5

T, U, V

Tape counter 11
Title 26
Tripod mounting 14
Trouble check 43
Twilight mode 24

W, X, Y, Z

Zoom 11