

Busca este producto en Gatoo.es

www.gatoo.es

Gatoo.es es una plataforma del grupo Sanelmann.

BOMANN®

User Manual

REFRIGERATOR WITH

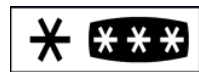

FREEZER SHELF

KS 163



Please read this manual carefully and keep for future reference!

TABLE OF CONTENT

OVERVIEW	3
MEANING OF THE “DUSTBIN” SYMBOL	3
IMPORTANT USE AND SAFETY INSTRUCTIONS	3
General safety precautions	3
Risk of injury	4
Coolant	4
Intended use	4
Unpacking	4
PRODUCT DESCRIPTION	5
Delivery scope	5
Specifications	5
INSTALLATION	6
Location	6
Power supply	6
REVERSE THE DOOR OPENING	7
STARTUP/ OPERATION	8
Prior to first use	8
Turning on	8
Storing food	8/9
Defrosting	9/10
Operating noise	10
Turning off	10
TIPS FOR SAVING ENERGY	10
MAINTENANCE AND CLEANING	11
Cleaning and care	11
Reverse the bulb	11
Repairs	11
What if . . . Troubleshooting	11/12

OVERVIEW



Please read this user manual thoroughly before first time operation. It includes important information with regard to installation, operation and maintenance of the device. Improper use may cause hazardous situations, especially for children.

Keep this manual for future reference. Pass it on to any future owner of this product. In case of any doubt regarding questions or topics which are not extensively described in this manual, please contact your distributor or a technician.

MEANING OF THE “DUSTBIN” SYMBOL



This product is marked in accordance with the European waste regulation 2002 / 96 / EC - WEEE

It regulates the proper disposal of the product. Environmentally friendly disposal will prevent possible negative consequences to health caused by improper disposal.

This symbol on the product or its packaging indicates that this product must not be disposed of with the regular household waste. The user has to return the product to a collection point for the recycling of electric and electronic equipment.

The disposal must comply with the local regulations in place.

For further information please contact your local authorities or waste collection service.

Disable waste equipment before disposal:

- Disconnect the mains plug from the wall socket.
- Disconnect the plug from the mains cable.
- Remove or disable any existing spring or latch locks.

This will prevent children from locking themselves (risk of suffocation!) or from getting into perilous situations. Children might not understand the risks that arise from handling household devices. Therefore, observe children and make sure they do not play with the device.

IMPORTANT USE AND SAFETY INSTRUCTIONS

General safety precautions

All safety information in this user manual are marked with a warning symbol. They indicate possible dangers precociously. It is imperative to read and follow these information.





WARNING

Do not touch the plug at the mains cable with wet or moist hands when connecting or disconnecting. Risk of death by electric shock!

- In case of emergency, unplug the device immediately.
- Hold the plug when disconnecting the mains cable; do not pull the cable.
- Disconnect the plug before cleaning or servicing.
- Regularly check the device and cable for signs of damage. Do not continue to operate the device in case of damage.
- A damaged mains cable must be replaced by the manufacturer or a technician and without any delay. Do not use the device with a damaged cable or plug.
- Do not repair the device by yourself. Please contact authorized personnel. In order to avoid hazards. A damaged mains cable must be replaced with an equivalent cable by the manufacturer or qualified specialist.
- Except for cleaning and maintenance work described in this manual, no other alterations of this device must be executed.
- Do not place vases or other containers filled with liquids on the device.

Risk of injury!

- So that you can disconnect the appliance quickly in event of an emergency, do not use extension cables.
- This device may not be operated by children or persons with physical, sensory or mental abilities or lack of experience and knowledge, unless they are supervised or guided.
- Children should be supervised to ensure that they do not play with the device.
- Transport the unit never with content.

	WARNING Packaging materials (e.g. plastic bags, polystyrene) are dangerous for children. Risk of suffocation! Keep packaging materials out of reach of children.
	WARNING Containers with flammable gases or liquids can leak due to cold ambient temperatures. Risk of explosion! Do not store combustible materials such as aerosol cans or refill cartridges for lighters in your device.

Coolant

	CAUTION The coolant circuit of this device contains the refrigerant isobutane (R600a), a natural gas that is flammable and of high environmental compatibility. Make sure no parts of the Coolant circuit gets damaged during transport and installation of the device.
---	---

If the coolant circuit is damaged:

- it is imperative to avoid any open flames or ignition source.
- thoroughly air the room in which the device is installed.

Intended use

- This device is intended for private use. It is suitable for cooling/freezing food.
- The manufacturer is not reliable for any damage resulting from improper or other than intended use.
- For safety reasons, alterations or modifications of the device are prohibited.
- Please keep in mind that the manufacturer is not reliable for any damage resulting from commercial or any other use than cooling/freezing food.

Unpacking

The packaging must be undamaged. Check the device for any possible transport damage. Do not install a damaged device. In case of damage, please contact your distributor.

Packaging material

The packaging for transportation of the device and individual parts is produced of recyclable materials.

- corrugated cardboard / paperboard (mainly of waste paper)
- form part of PS (foamed, CFC-free polystyrene)
- Films and bags of PE (polyethylene)
- Strapping strips of PP (polypropylene)

	WICHTIG Make sure you dispose of packaging materials environmentally friendly (see page 3).
---	---

Removing the transport protection

The device and parts of the interior are protected for transport. Remove all adhesive tapes from the right and left side of the door. You may remove adhesive residue with a cleaning solvent. Also remove any adhesive tapes and packaging materials from the inside of the device.

PRODUCT DESCRIPTION

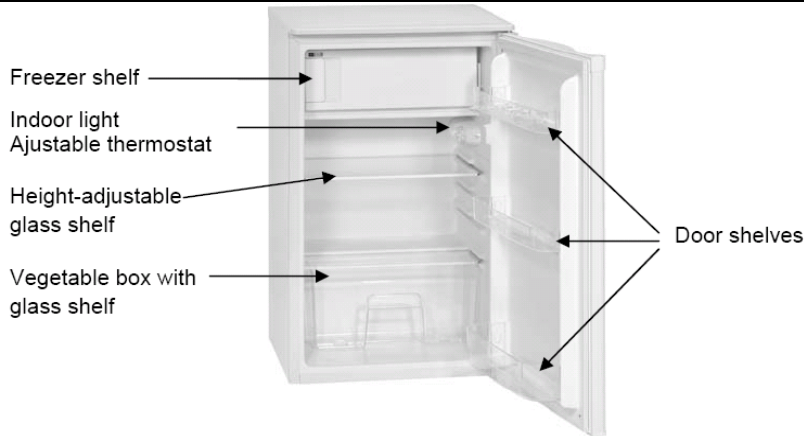

Delivery scope

The delivery scope of this device includes one height-adjustable glass shelf, a vegetable box with glass cover, three door shelves, an egg tray and an ice-cube tray.

Specifications

BOMANN Model No.	KS 163
Energy efficiency class ⁽¹⁾	A+
Climate class ⁽²⁾	N
Gross / net capacity, total	101 l / 98 l
Net capacity refrigerator / freezer shelf	87 l / 11 l
Freezing capacity	1 kg / 24 h
Storage time in case of defect	10 h
Power consumption ⁽³⁾	0,45 kWh/24h - 164 kWh/year
Power supply	220-240 V, 50 Hz
Input power	90 W
Operating noise	42 dB(A)
Dimensions H x W x D	84,7 x 49,4 x 49,4 cm
Gross / net weight	31,0 / 28,0 kg
Coolant	R600a
⁽¹⁾ A= economical - G= less economical ⁽²⁾ Climate class SN (Subnormal): ambient temperature of +10°C up to +32 C Climate class N (Normal): ambient temperature of +16 C up to +32 C Climate class ST (Subtropics): ambient temperature of +18 C up to +38 C Climate class T (Tropics): ambient temperature of +18 C up to +43 C ⁽³⁾ The actual energy consumption depends on the use and installation of the device.	

All device-specific data of the energy label have been determined by the manufacturer under laboratory conditions in accordance with pan-European standardized measuring methods. These are regulated by EN ISO 15502. The actual energy consumption depends on the usage and might therefore also be above the values determined by the manufacturer under standard conditions.

An expert knows these relations and will execute the tests with special measurement instruments in accordance with the regulations in place.

MANUFACTURER DATA

Product is subject to changes and improvements.

INSTALLATION

Location

Sufficient ventilation around the device is necessary in order for the heat to dissipate properly and to guarantee efficient cooling operation at low power consumption. For this purpose, leave sufficient space around the device.

- Minimum clearance of 10 cm between rear side and wall,
- at least 2 cm on both sides and 5 cm on top of the device.
- Leave proper space in front of the device in order to open the door at an angle of 160°.

IMPORTANT

- Do not expose the device to direct sunlight.
- Do not place near heaters, next to a stove or any other heat sources.
- Do not use the device outdoors.
- Only install at a location with an ambient temperature suitable for the climate class of the device.
For information on the climate class, please refer to chapter "Specifications" or to the rating label located in the interior or on the rear side of the device.
- Avoid installation at locations with high humidity (e.g. outdoors, bathroom), as metal parts would be susceptible to corrosion under such circumstances.
- Do not place the device near volatile or combustible materials (e.g. gas, fuel, alcohol, paint, etc.) and in rooms which may have poor air circulation (e.g. garages).
- Only place on a steady and safe surface.
- If the device is not horizontally leveled, adjust the feet accordingly.

Power supply

The kind of current (AC) and the voltage must be conform with the data of the rating label, located inside or outside on the back of the unit. In case of heavy voltage fluctuations, it is recommended to use an automatic alternating current regulator.

The plug, together with the grounding conductor, must fit into the wall socket. The mains plug must be freely accessible.

Mains cable

- Do not extend or roll up the cable during operation.
- Also, the cable must not be near the compressor on the rear side, since latter one gets hot during operation. In case of any contact, the isolation would be damaged resulting in electric leakage.
- The use of extension cables is not recommended.
- Do not connect the device to the mains with wet hands.
- Install the device for the wall socket to be freely accessible.

REVERSE THE DOOR OPENING

If required, the door opening can be moved from the right (supplied condition) to the left side.



WARNING

When replacing the door stop, the device must be disconnected from the power supply. Always unplug the device first.

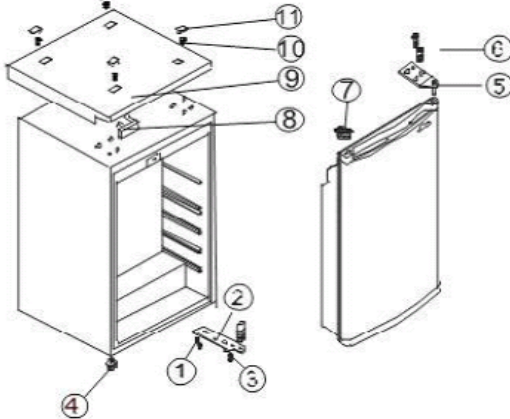

1. Use a screw-driver to remove the screw covers (11) at the device top cover. Unscrew the below screws (10) and remove the device cover (9).
2. Put the blind cap (8) of the device top cover (9) at the opposite side.
3. Dismount the upper door hinge (5) by unscrewing the screws (6).
Open the door a little, take the door carefully from the lower door hinge (2).
4. Put the blind cap (7) of the device door at the opposite side and place the door on a padded surface to prevent it from scratches.
5. Tilt the device slightly backwards and block it in this position.
Unscrew both feet (3) and (4) and remove the lower door hinge (2) by unscrewing the screws (1).
6. Move the hinge (2) to the other side of the device accordingly and fix it with the screws (1).
Screw both feet (3) and (4) on again.
7. Replace the device in the upright position again. Insert the device door on the hinge pin of the lower door hinge (2) and fix the door to the property position.
8. Attach the upper door hinge (5) by using the screws (6) to the opposite side accordingly.
9. Put the in point 1 removed device top cover on again, tight the screws (10) and clip the screw covers (11) on.

Check if the door is arranged vertical as well as horizontal, so that a smooth opening and closing of the door is ensured.

Reverse the freezer flap opening

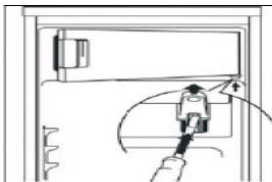

Open the freezer flap a little. Press the spring of the lower bracket up slightly with a small screw-driver and remove the bracket incl. freezer flap.

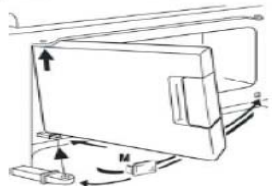

Place the blind cap (M) at the opposite side. Turn the freezer flap about 180° and press the lower flap bracket into the appropriated fixture of the freezer flap.

Lift the freezer flap a little and fix it in the upper door bracket, at the same time you press the lower door bracket in the square hole. Small adjustments to the top and bottom will easily the mounting of the flap.

STARTUP / OPERATION



Prior to first use

	ATTENTION After transport, the device should be left standing for 4 hours in order for the oil to be collected in the compressor.
---	---

Nonobservance could cause damage to the compressor and hence result in failure of the device. This would void your warranty claim.

- Clean the interior of the device including all accessory parts located inside.

Connect the device to the mains supply

	IMPORTANT The device must be earthed properly. For this purpose the plug of the mains cable has been fitted with the intended lead.
	IMPORTANT Contact an electrician if the plug does not fit in the wall socket.
	IMPORTANT In case you disconnect the device or in case of power failure: Wait for 5 minutes before restarting the device.

Turning on

Turn on the device by connecting the plug to a wall socket and turning the temperature control, which is located at the right side of the interior. Please also refer to chapter "Settings".

Settings

Setting 0 – OFF indicates the device is turned off.

Turn the temperature control clockwise, starting from this setting; the device will turn on automatically.

The Settings 1 MIN – 7 MAX regulate the inside temperature. When opening the door, the interior lamp will turn on.

Setting 0 (or OFF)	=	Off
Setting 1 (or MIN)	=	lowest setting (warmest inside temperature)
Setting 7 (or MAX)	=	highest setting (coldest inside temperature)

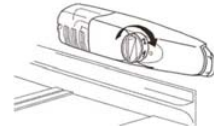

Turning the temperature control clockwise will lower the inside temperature. Please keep in mind that the temperature changes with the ambient temperature (of the location), with the frequency of opening the door and the amount of food in the device.

During initial operation, turn the temperature control to the highest setting first, until the device has reached the desired operating temperature. Afterwards It is recommended to turn the control back to a medium setting, correcting the temperature at a later point would then be easier.

Storing food - Refrigerator

Note: Always store food covered or packed in order to prevent drying-out and transfer of odor or taste onto other food items.

You may pack the food with:

- Polyethylene plastic bags or foil
- Plastic containers with a lid
- Special elasticated plastic covers
- Aluminum foil

The following safety precautions are recommended

- The device is suitable for storing fresh food and drinks.
- Store fresh packed items on the glass shelves and fresh fruits and vegetables in the vegetable box.
- Place bottles in the shelves of the inside of the door.

- Store meat well packed and only for 2 to 3 days. Avoid contact with cooked dishes.
- Let warm food cool down before putting it in the device.

Storing food – Freezer shelf

The  freezer allows you to store frozen food at a temperature of -18°C or below (from a middle temperature control setting) for several months, to produce ice cubes and to freeze fresh good.

The temperature of the device is automatically controlled by the temperature control in the refrigerator. Due to external influences such as room temperature, placements, frequency of opening the door and the amount of food the temperature in the freezer can be influenced.

Freezing

- 24 hours before freezing we recommend to turn the temperature control to the max. setting and to keep this setting even after freezing for a few hours.
The device is not compromised if the setting will not revert to a normal operating temperature (temperature control in middle setting) after the freezing process, but for economic reasons you should possibly avoid it.
- Fresh food should be frozen as fast as possible to the core. Therefore during freezing operation, the temperature of fresh food should be lowered as fast as possible in order to keep formation of ice crystals as little as possible and not to damage the food structure.
- If the freezing process is too slow, ice crystals build up and the food quality might get affected.
- Frozen food should be kept in contact with the bottom of the compartment.
- Keep a space between the single items for air circulation.

Storing frozen food

- Packed frozen merchandise should be stored in a 4-star-freezer compartment in accordance with the manufacturer's data. Make sure the food items do not defrost after purchase and to store them as fast as possible in the freezer.
- It is possible to store food for longer periods of time, up to three months. This period might vary, so please observe the storage information on the packaging of the merchandise.

	<p>IMPORTANT</p> <p>Make sure that the temperature in the freezer does not rise above -18°C. Moreover the device should be defrosted regularly. A thick layer of ice on the wall deteriorates the cooling effect and the power consumption increases.</p>
---	--

Safety precautions

- Do not store sizzling drinks in this device, such as mineral water, beer, sparkling wine, coke etc. (risk of explosion).
- Once products have been defrosted halfway or completely, they should be consumed as soon as possible and should not be frozen again, except they have been processed to a ready meal.
- In case of power failure, do not open the door. If the failure does not take longer than 10 hours, the food will not be affected.
- Do not store bottles or cans. These can break when the contents freeze – or even explode, if they contain carbonated drinks.
- Do not eat food that is still frozen. Do not allow children to eat ice cream directly from the freezer. The cold can cause injuries in the oral cavity.
- Touching metal parts inside the device can cause symptoms similar to burns if the skin is very sensitive.
- Do not touch frozen food with moist or wet hands; they could freeze to the items.

Defrosting

The **refrigerator** has a automatic defrosting system.

During defrosting the water drops drain off at the rear side of the cooling chamber.

The water running through a flume, is collected in a container underneath the compressor, where it will evaporate. Make sure the flume does not get clogged. Clean it carefully with a pipe cleaner or knitting needle. A light formation of ice on the rear side during operation is normal.

To achieve better cooling and to save energy, defrost the **freezer shelf** regularly. To start the defrosting process turn the temperature control to the position 0 - OFF and disconnect the plug. Remove the food items and keep covered at a cool location.

When the ice has melted, pour the condensate away and dry the interior of the device.
You may then restart the device by connecting the plug and turning the temperature control.



WARNING

Never use metal objects (e.g. knives) for removing ice from the vaporizer. The vaporizer could be damaged. A defect vaporizer could cause serious damages.

Operating noise

	TYPE OF SOUND	CAUSE/ SOLUTION
NORMAL NOISE	Mumbling	Caused by the compressor during its operation. This is stronger when it turns on or off.
	Liquid sounds	Caused by the circulation of the refrigerant in the device.
	Click sounds	The temperature control turns the compressor on or off.
	Disturbing noises	Vibration of the shelves or cooling coils – check if those are securely fastened.

Turning off

Turn the temperature to setting 0 – OFF in order to turn off the device.

If the device will not be operated for a longer period of time:

- Remove the entire food from the device.
- Turn the temperature control to setting 0 - OFF.
- Disconnect the plug or turn off / unscrew the fuse.
- Thoroughly clean the device (refer to chapter of “Cleaning and Care”).
- Keep the door open in order to prevent bad odors.



TIPS FOR SAVING ENERGY

- Disconnect the plug if you do not use the device.
- Do not install the device near stoves, heaters or other heat sources. In case of higher ambient temperatures, the compressor will run more frequently and longer.
- Ensure sufficient ventilation at the bottom and rear side of the device.
Never block any ventilation openings.
- Allow warm dishes to cool down before putting them in the device.
- Do not open the door longer than necessary.
- Only set the temperature as low as needed. The ideal temperature in the fridge is 7°C.
It should be measured in the upper shelf, as far as possible in the front.
- Make sure that the temperature in the freezer does not rise above -18°C.
- The freezer should be defrosted regularly.
- Always keep the condenser – metal grid on the rear side (if existing) – clean.
- Make sure the door sealing is in good order for the door to close properly.

MAINTENANCE AND CLEANING

Cleaning and care

For hygienic reasons, clean the interior and accessory parts regularly.

	WARNING Always disconnect the plug or turn off/ unscrew the fuse before cleaning. Pull the plug and not the cable.
	WARNING Do not use steam cleaners for cleaning the device; moisture could enter electrical components. Risk of electric shock! Hot steam could damage the plastic parts. The device must be dry before restarting operation.
	IMPORTANT Essential oils and organic solvents, such as the juice of lemon or orange skin, butanoic acid or cleaning agents containing acetic acid can damage plastic parts. Prevent contact of any part with such substances. Do not use abrasive cleaning agents.

- Remove all food and keep covered at a cool location.
- Use warm water and a mild detergent for cleaning the interior (including rear side and bottom).
- Check the discharge opening.
- After thorough drying, restart operation.
- Clean the condenser - metal grid on the rear side (if existing) once a year, using a soft brush or vacuum cleaner.

	WARNING Do not bend the cooling coils. Do not use arenaceous abrasives.
---	--

Reverse the bulb

Lamp specifications: 220-240V, max. 15W

To turn off the device, set the temperature control to setting 0 - OFF.

Disconnect the plug or turn off the fuse!

- Remove the screw from the lamp cover.
- Press on the lamp cover and remove to the back.
- Replace defect illuminant.
- Reattach the lamp cover and fasten the screw.
- Reconnect the device and turn on.

Repairs

	WARNING Servicing of electric devices must be conducted by qualified experts only. Incorrect or improper repairs constitute a risk for the user and will void the warranty!
---	---

What if . . . Troubleshooting

The design of the device ensures a trouble-free operation as well as a long life cycle. Nevertheless, if any defect occurs during operation, please check if it is caused by improper operation.

The following problems can be solved by you by checking for the possible cause.

PROBLEM	POSSIBLE CAUSE	SOLUTION
The device is not cooling properly or at all	Is the plug securely connected to the mains? Has the safety mechanism of the wall socket been triggered? Is the temperature control properly set? Is the place unqualified? Do food items prevent the door from closing properly? Is the ventilation of the device hedged?	Connect the plug properly to the socket, turn on the fuse, and contact a technician if necessary. Check the settings. Check the ambient temperature. Arrange the food properly. Clear the ventilation slits, install the device freely

Loud noise during operation	Does the device not stand vertical or horizontal?	Adjust the feet accordingly. Liquid flow sounds in the cooling circuit are normal.
Water on the bottom.	Is the temperature control set properly? Is the condensate flume clogged?	Check the temperature settings. Clean the discharge opening with a pipe cleaner or knitting needle.
Interior lamp does not work.	Is the plug not connected to the mains? Has the safety mechanism of the wall socket been triggered? Is the illuminant defect?	Connect the plug properly to the socket, turn on the fuse, and contact a technician if necessary. Disconnect the plug and replace the illuminant (refer to chapter "Replacing the illuminant").

Note. On days of high humidity, condensation might occur on the outer surface of the device. This is no malfunction; you may simply wipe the water off.

If a problem still persists after following the steps above, please contact your distributor or a technician.

Are you interested in other Bomann products? Please visit our website:

www.bomann.de