

# Service Manual

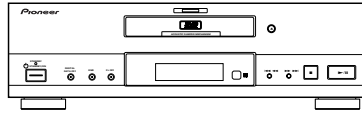

ORDER NO.  
RRV2010

## DVD PLAYER DV-717

THIS MANUAL IS APPLICABLE TO THE FOLLOWING MODEL(S) AND TYPE(S).

Type	Model	Power Requirement	Region restriction code (region number)	Remarks
	DV-717			
WY	○	AC220 – 240V	2	
WY/RD	○	AC220 – 240V	4	
WY/RE	○	AC220 – 240V	5	

- Refer to the service guide RRV2004 for DV-515.

### CONTENTS

1. SAFETY INFORMATION .....	2	7. GENERAL INFORMATION .....	56
2. EXPLODED VIEWS AND PARTS LIST .....	3	7.1 PARTS .....	56
3. SCHEMATIC DIAGRAM .....	10	7.1.1 IC .....	56
4. PCB CONNECTION DIAGRAM .....	33	7.2 DISASSEMBLY .....	59
5. PCB PARTS LIST .....	45	7.3 BLOCK DIAGRAM .....	60
6. ADJUSTMENT .....	50	7.4 CIRCUIT DESCRIPTION .....	62
		7.4.1 VIDEO SIGNAL PROCESSING BLOCK ..	62
		8. PANEL FACILITIES AND SPECIFICATIONS .....	63

# 1. SAFETY INFORMATION

This service manual is intended for qualified service technicians ; it is not meant for the casual do-it-yourselfer. Qualified technicians have the necessary test equipment and tools, and have been trained to properly and safely repair complex products such as those covered by this manual. Improperly performed repairs can adversely affect the safety and reliability of the product and may void the warranty. If you are not qualified to perform the repair of this product properly and safely, you should not risk trying to do so and refer the repair to a qualified service technician.

## IMPORTANT

THIS PIONNER APPARATUS CONTAINS LASER OF CLASS 1. SERVICING OPERATION OF THE APPARATUS SHOULD BE DONE BY A SPECIALLY INSTRUCTED PERSON.

## LASER DIODE CHARACTERISTICS

- FOR DVD  
MAXIMUM OUTPUT POWER : 7 mW  
WAVELENGTH : 650 nm
- FOR CD  
MAXIMUM OUTPUT POWER : 5 mW  
WAVELENGTH : 780-785 nm

## Additional Laser Caution

1. Inside detection switch (S201 on the SMEB assy) and loading-status detection switch (S301 on the LOSB assy) are detected by the microprocessor (IC501 in the DVDM assy).
  - To permit the laser diode to oscillate, it is required to set the inside detection switch for the inside position (S201 : ON) and to set the loading-status detection switch for the clamp position (the center terminal of S301 is shorted to +5V). The 650 nm laser diode for DVD oscillation will continue if pin 19 of IC101 is shorted to +5V (fault condition) in the DVDM assy. The 780 nm laser diode for CD oscillates if pin 20 of IC101 is shorted to +5V in the DVDM assy. In the test mode \* , the laser diode oscillates when microprocessor detects a PLAY signal, or when the PLAY key is pressed (S113 ON in the FLKB assy), with the above requirements satisfied.
2. When the cover is open, close viewing through the objective lens with the naked eye will cause exposure to the laser beam.

\* Refer to the service guide RRV2004.

## LABEL CHECK

CLASS 1  
LASER PRODUCT

(Printed on the Rear Panel)

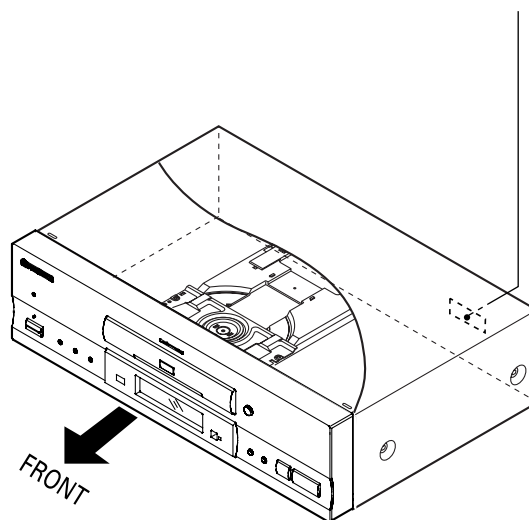

## 2. EXPLODED VIEWS AND PARTS LIST

- NOTES: ● Parts marked by "NSP" are generally unavailable because they are not in our Master Spare Parts List.  
 ● The ⚠ mark found on some component parts indicates the importance of the safety factor of the part. Therefore, when replacing, be sure to use parts of identical designation.  
 ● Screws adjacent to ▼ mark on product are used for disassembly.

### 2.1 PACKING

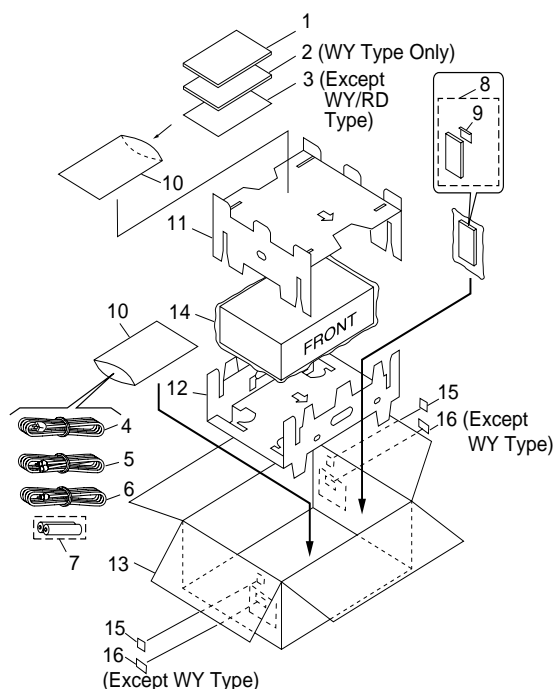

#### (1) PACKING PARTS LIST

Mark	No.	Description	Part No.
	1	Instruction Manual (English/French/German/Italian)	VRE1074
	2	Instruction Manual (Spanish/Portuguese/Dutch/Swedish)	VRF1045
NSP	3	Warranty Card	ARY7022
⚠	4	Power Cord	ADG1127
	5	Audio Cord (L=1.5m)	VDE1033
	6	Video Cord (L=1.5m)	VDE1048
NSP	7	Battery(R6P,AA)	VEM-013
	8	Remote Control Unit (CU-DV025)	VXX2601
	9	Battery Cover	VNK4334
	10	Polyethylene Bag	Z21-038
	11	Protector A	VHB1065
	12	Protector B	VHB1066
	13	Packing Case	VHG1779
	14	Mirror Mat Sheet	VHL1012
	15	Region Label	See contrast table (2)
	16	Label	See contrast table (2)

#### (2) CONTRAST TABLE

WY, WY/RD and WY/RE types are constructed the same except for the following :

Mark	No.	Symbol and Description	Part No.			Remarks
			WY type	WY/RD type	WY/RE type	
NSP	2	Instruction Manual (Spanish/Portuguese/Dutch/Swedish)	VRF1045	Not used	Not used	
	3	Warranty Card	ARY7022	Not used	ARY7022	
	15	Region Label P2	VRW1701	Not used	Not used	
	15	Region Label P4	Not used	VRW1705	Not used	
	15	Region Label P5	Not used	Not used	VRW1755	
	16	RD Label	Not used	VRW1761	Not used	
	16	RE Label	Not used	Not used	VRW1756	

## 2.2 EXTERIOR SECTION

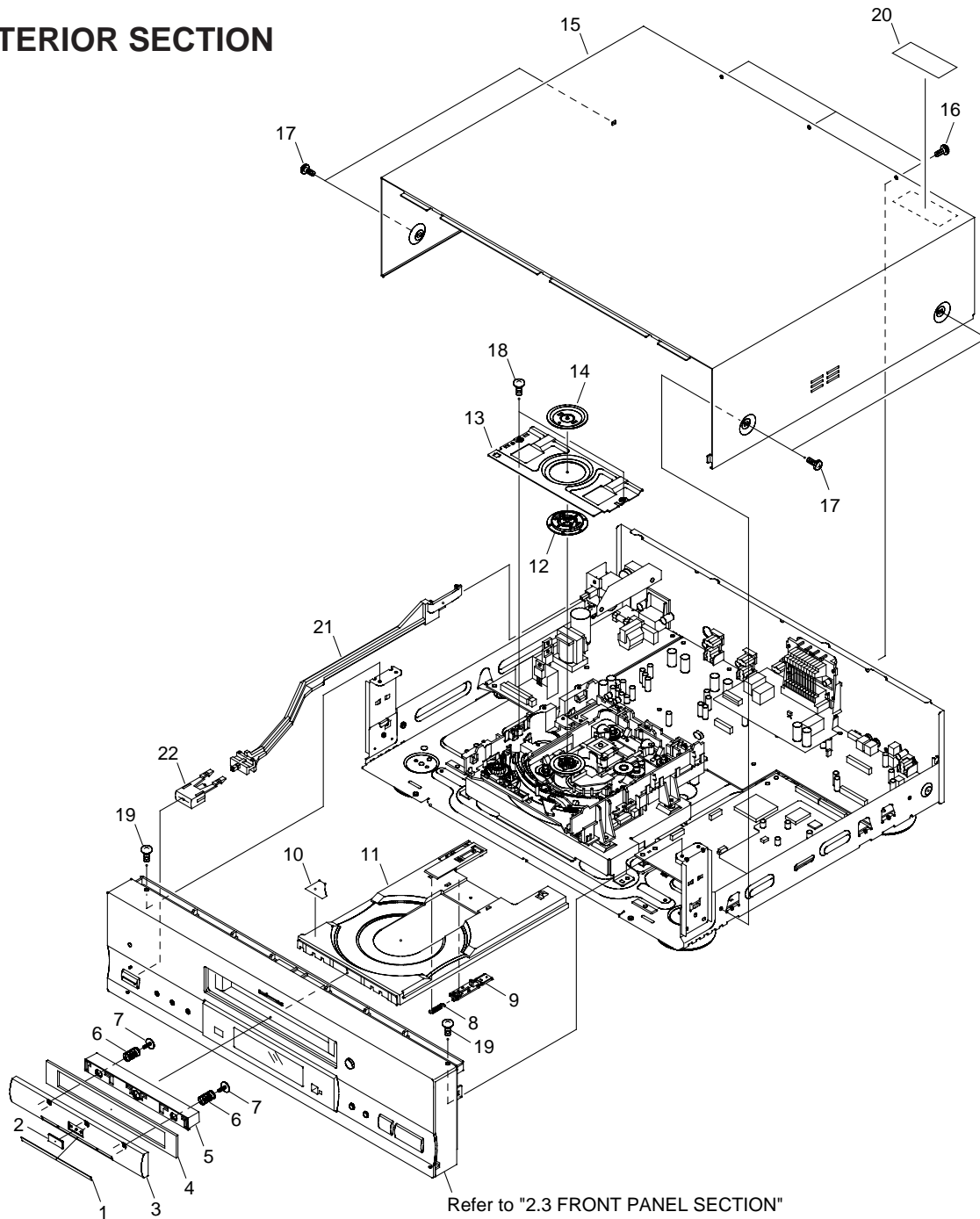

### (1) EXTERIOR SECTION PARTS LIST

Mark No.	Description	Part No.	Mark No.	Description	Part No.
1	Door Plate	VAH1312	11	Tray	VNK4333
2	DVD Plate	VAM1077	12	Clamper	VNL1738
3	Door Panel	VNK4324	13	Bridge	VNE2069
4	Door Cushion	VEC2008	14	Clamper Plate	VNE2068
5	Door Holder	VNK4325	15	Bonnet Case S	VXX2617
6	Door Spring	VBH1305	16	Screw	BBZ30P080FMC
7	Screw	VBA1057	17	Screw	BCZ40P060FNI
8	Spring	VBH1277	18	Screw	BPZ26P080FZK
9	Tray Stopper	VNL1739	19	Screw	BBT30P080FCC
10	Label	VRW1628	20	Label	VRW1699
			21	PW Joint	VNK4327
			22	Power Button	VNK4159

## 2.3 FRONT PANEL SECTION

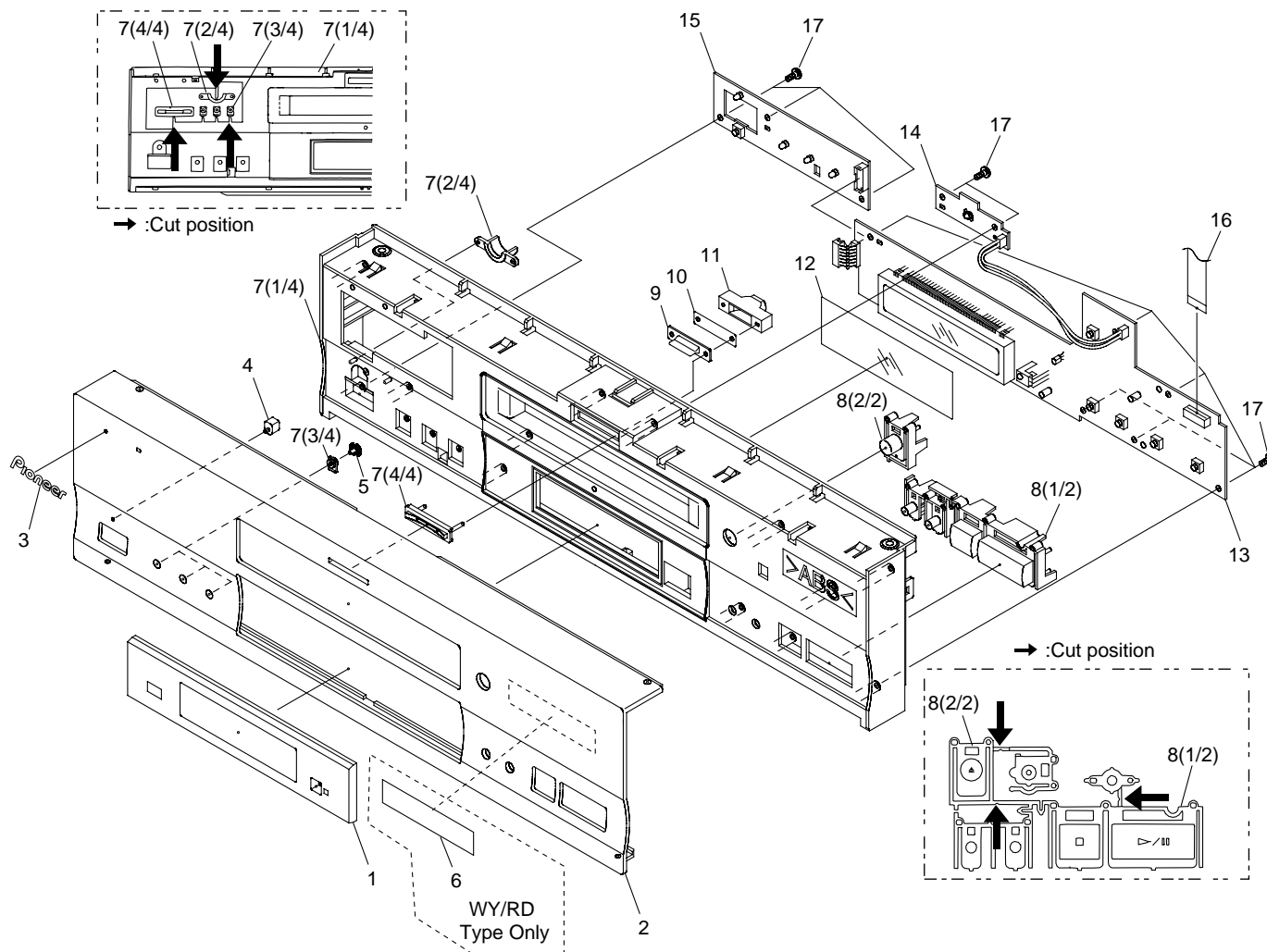

### (1) FRONT PANEL SECTION PARTS LIST

Mark	No.	Description	Part No.	Mark	No.	Description	Part No.
	1	FL Lens	VEC2007		11	Illumi Holder	VNK4098
	2	Front Almi	VAH1298		12	FL Filter	VEC2016
	3	Name Plate G	PAN1377		13	FLKY Assy	VWG1980
	4	LED Lens	PNW2019	NSP	14	DIRB Assy	VWG1991
	5	LED Lens	VNK4326	NSP	15	PWSB Assy	VWG1988
NSP	6	Getter	See contrast table (2)	16	Flexible Cable	VDA1690	
	7	Panel Base	VNK4323	17	Screw	BBZ30P080FMC	
	8	Main Key	VNK4095				
	9	Illumination Lens	VNK4168				
	10	Illumination Filter	VEC1950				

### (2) CONTRAST TABLE

WY, WY/RD and WY/RE types are constructed the same except for the following :

Mark	No.	Symbol and Description	Part No.			Remarks
			WY type	WY/RD type	WY/RE type	
NSP	6	Getter	Not used	VRW1757	Not used	

## 2.4 BOTTOM SECTION

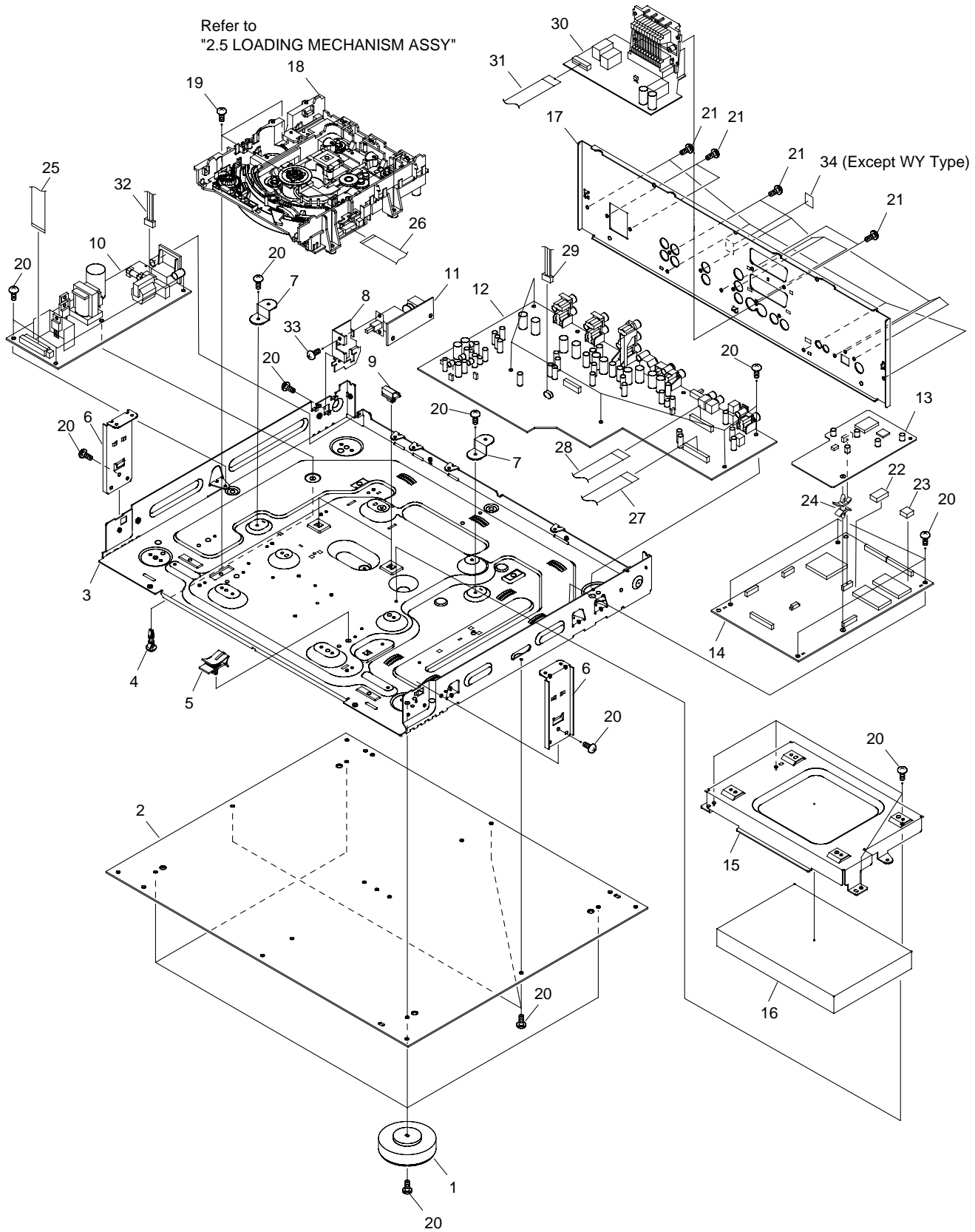

**(1) BOTTOM SECTION PARTS LIST**

Mark	No.	Description	Part No.	Mark	No.	Description	Part No.
	1	Insulator	PNW2766		21	Screw	BBZ30P080FMC
NSP	2	Bottom Plate	PNA2376	NSP	22	PC Support Cushion	VEC2033
NSP	3	Chassis	VNA1979	NSP	23	PC Support Spacer	VEC2032
NSP	4	PCB Holder	PNW2029		24	PC Support	DEC1932
	5	Flat Cable Clip	VEC2018		25	Flexible Cable (26p)	VDA1688
NSP	6	Panel Stay	VNE2156		26	Flexible Cable (12p)	VDA1692
NSP	7	PCB Base	RNE1221		27	Flexible Cable (26p)	VDA1694
NSP	8	Power-Holder	VNE2123		28	Flexible Cable (22p)	VDA1696
NSP	9	P.Plate Holder	PNY-405		29	Connector Assy	PF02PP-S20
△	10	Power Supply Unit	VWR1306		30	SCRB Assy	VWV1623
NSP	11	MSWB Assy	VWG1996		31	Flexible Cable (22p)	VDA1699
	12	AVJB Assy	VWV1617	△	32	Housing Assy	VKP2194
	13	DNRB Assy	VWV1619		33	Screw	PMB30P080FZK
	14	DVDM Assy	VWS1349		34	Region Label	See contrast table (2)
NSP	15	Mecha Holder	VNE2157				
	16	Mecha Cushion	VEC2011				
	17	Rear Panel	See contrast table (2)				
NSP	18	Loading Mecha. Assy	VWT1157				
	19	Screw	BBZ30P100FMC				
	20	Screw	ABZ30P080FCC				

**(2) CONTRAST TABLE**

WY, WY/RD and WY/RE types are constructed the same except for the following :

Mark	No.	Symbol and Description	Part No.			Remarks
			WY type	WY/RD type	WY/RE type	
	17	Rear Panel	VNA1996	VNA2043	VNA2043	
	34	Region Label R4	Not used	VRW1704	Not used	
	34	Region Label R5	Not used	Not used	VRW1754	

## 2.5 LOADING MECHANISM ASSY

### • Top View

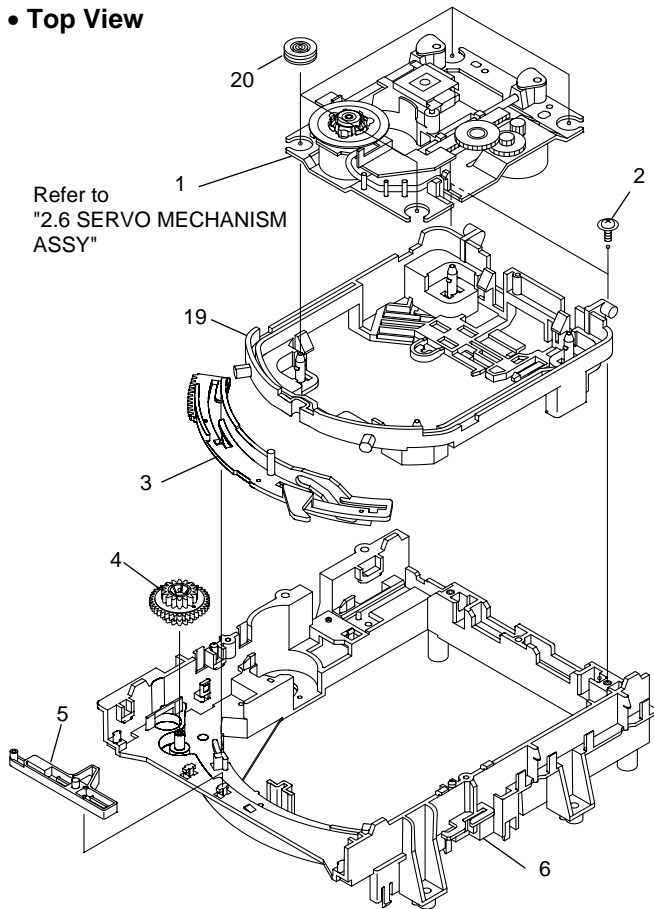

### • Bottom View

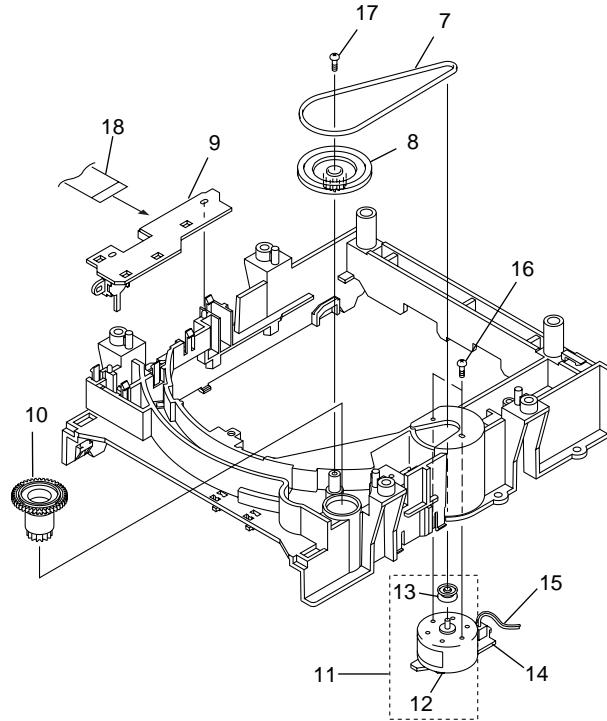

## LOADING MECHANISM ASSY PARTS LIST

Mark	No.	Description	Part No.
	1	Servo Mechanism Assy-S	VXX2606
	2	Screw	DBA1006
	3	Drive Cam	VNL1736
	4	Drive Gear	VNL1735
	5	Lock Plate	VNL1820
	6	Loading Base	VNL1730
	7	Belt	VEB1260
	8	Gear Pulley	VNL1733
NSP	9	LOSB Assy	VWG1885
	10	Loading Gear	VNL1734

Mark	No.	Description	Part No.
	11	Loading Motor Assy	VXX2505
	12	DC Motor / 0.3W	PXM1027
	13	Motor Pulley	PNW1634
NSP	14	LOMB Assy	VWG1886
	15	Connector Assy (LOMB CN401 – LOSB CN306)	VKP2184
	16	Screw	VBA1055
	17	Screw	Z39-019
	18	Flexible Cable (08P) (LOSB CN303 – SMEB CN202)	VDA1698
	19	Float Base	VNL1815
	20	Floating Rubber	VEB1286



## 2.6 SERVO MECHANISM ASSY

### • Top View

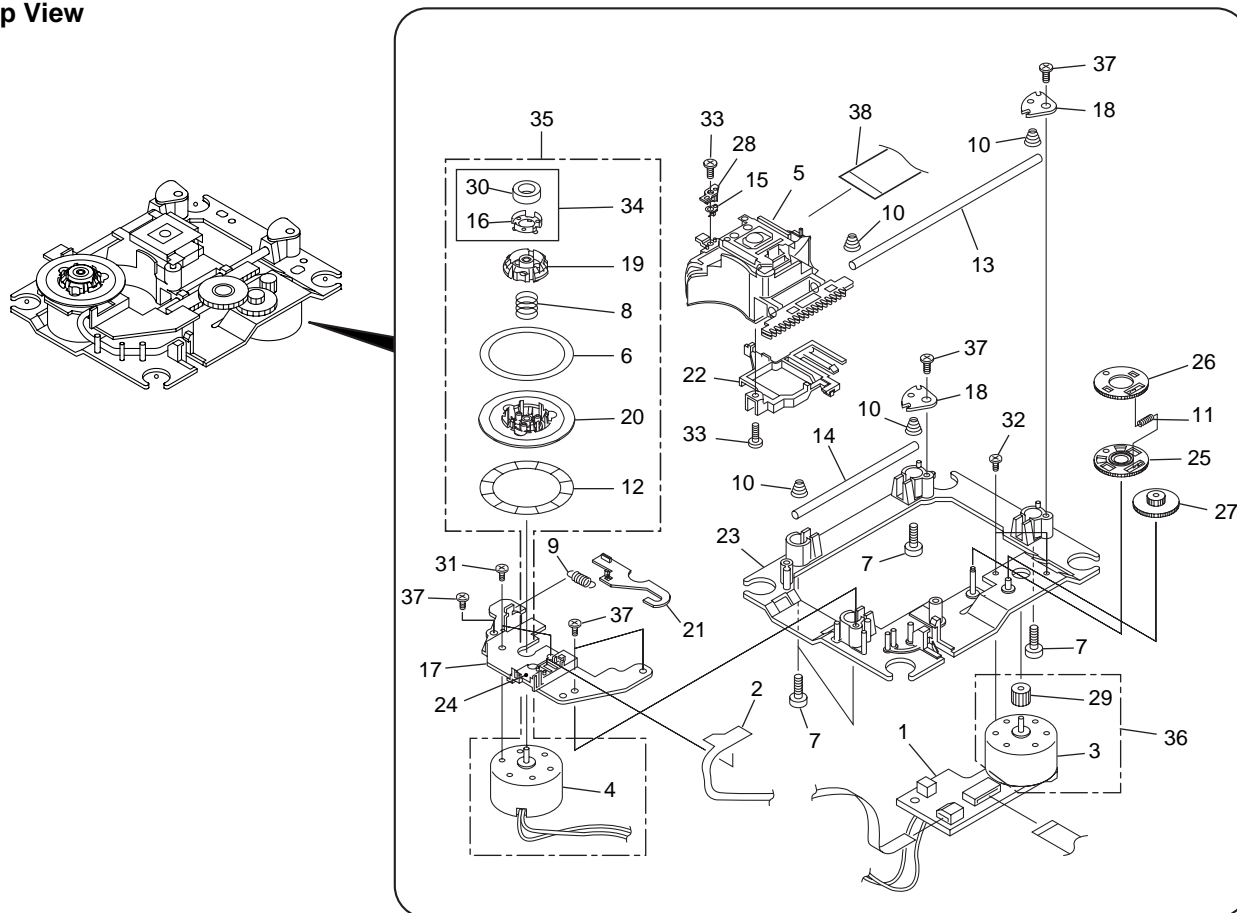

### SERVO MECHANISM ASSY PARTS LIST

Mark	No.	Description	Part No.	Mark	No.	Description	Part No.
NSP	1	SMEB Assy	VWG1968		21	Hook	VNL1770
NSP	2	FGSB Assy	VWG2009		22	FFC Holder	VNL1802
	3	Motor	VXM1074		23	Mechanism Base	VNL1806
	4	Motor	VXM1075		24	FG Holder	VNL1807
△	5	Pickup Assy	VWY1050		25	Gear A	VNL1808
	6	Table Sheet	DEC2040		26	Gear B	VNL1809
	7	Screw	VBA1058		27	Gear C	VNL1810
	8	Centering Spring	VBH1278		28	Slider	VNL1811
	9	Hook Spring	VBH1291		29	Gear D	VNL1814
	10	Skew Spring	VBH1303	NSP	30	Magnet	VYM1024
	11	Gear Spring	VBH1308		31	Screw	JFZ17P025FZK
NSP	12	Reflected Sheet	VEC1959		32	Screw	JGZ17P028FMC
	13	Guide Bar	VLL1504		33	Screw	VBA1051
	14	Sub-guide Bar	VLL1505		34	Magnet Holder Assy	VXX2507
	15	Hold Spring	VNC1017		35	Spindle Motor Assy	VXX2604
NSP	16	Magnet Holder	VNE2070		36	Carriage Motor Assy	VXX2605
NSP	17	Motor Base	VNE2154		37	Screw	PBA1069
NSP	18	Cover	VNE2155		38	Flexible Cable (24P) (DVDM CN120 – Pickup Assy)	VDA1701
NSP	19	Centering Ring	VNL1746				
NSP	20	Disc Table	VNL1747				



Note : When ordering service parts, be sure to refer to "EXPLODED VIEWS and PARTS LIST" or "PCB PARTS LIST".

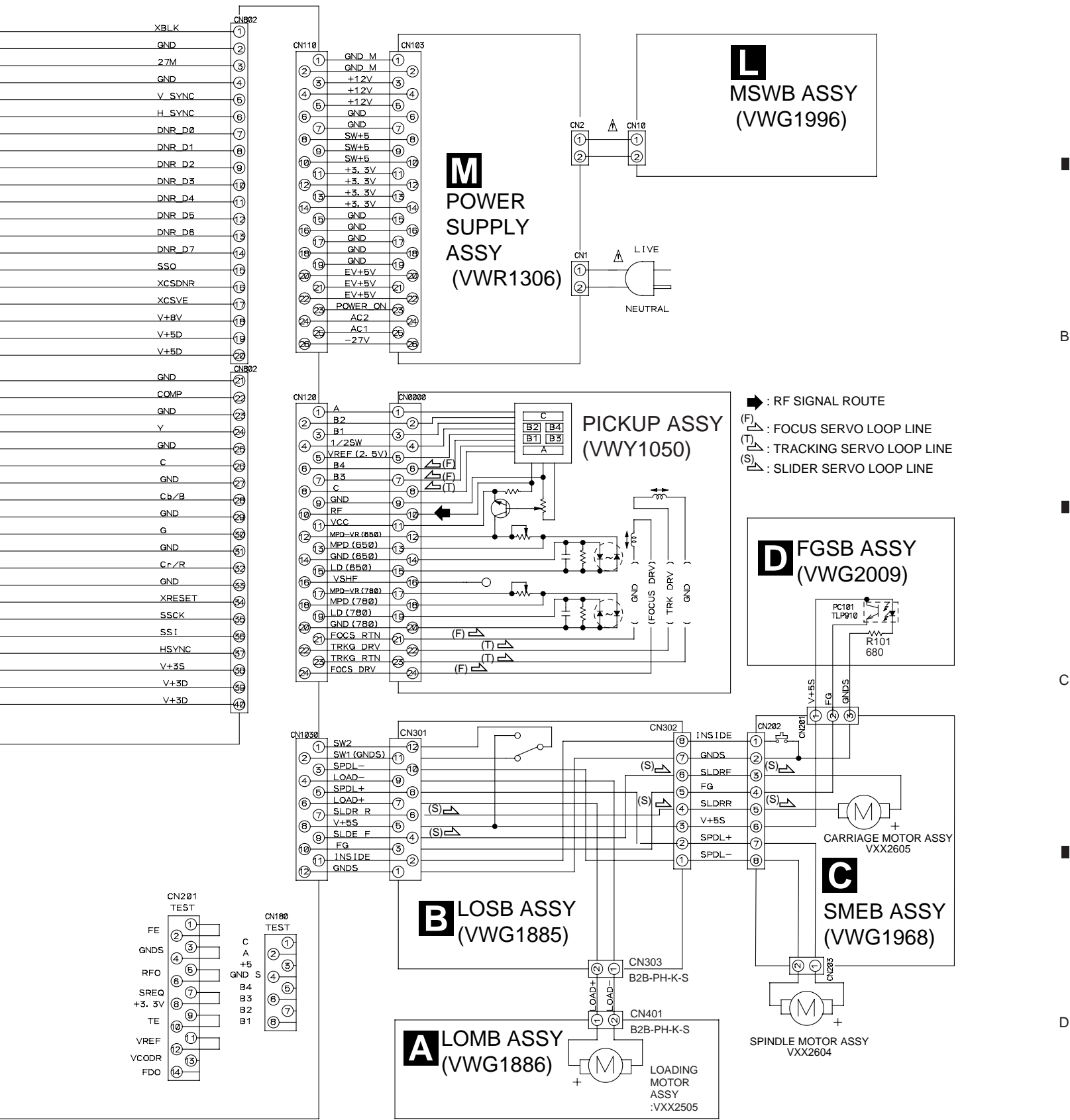

3.2 FLKY, PWSB and DILB ASSEMBLIES

FLKY ASSY (VWG1980)

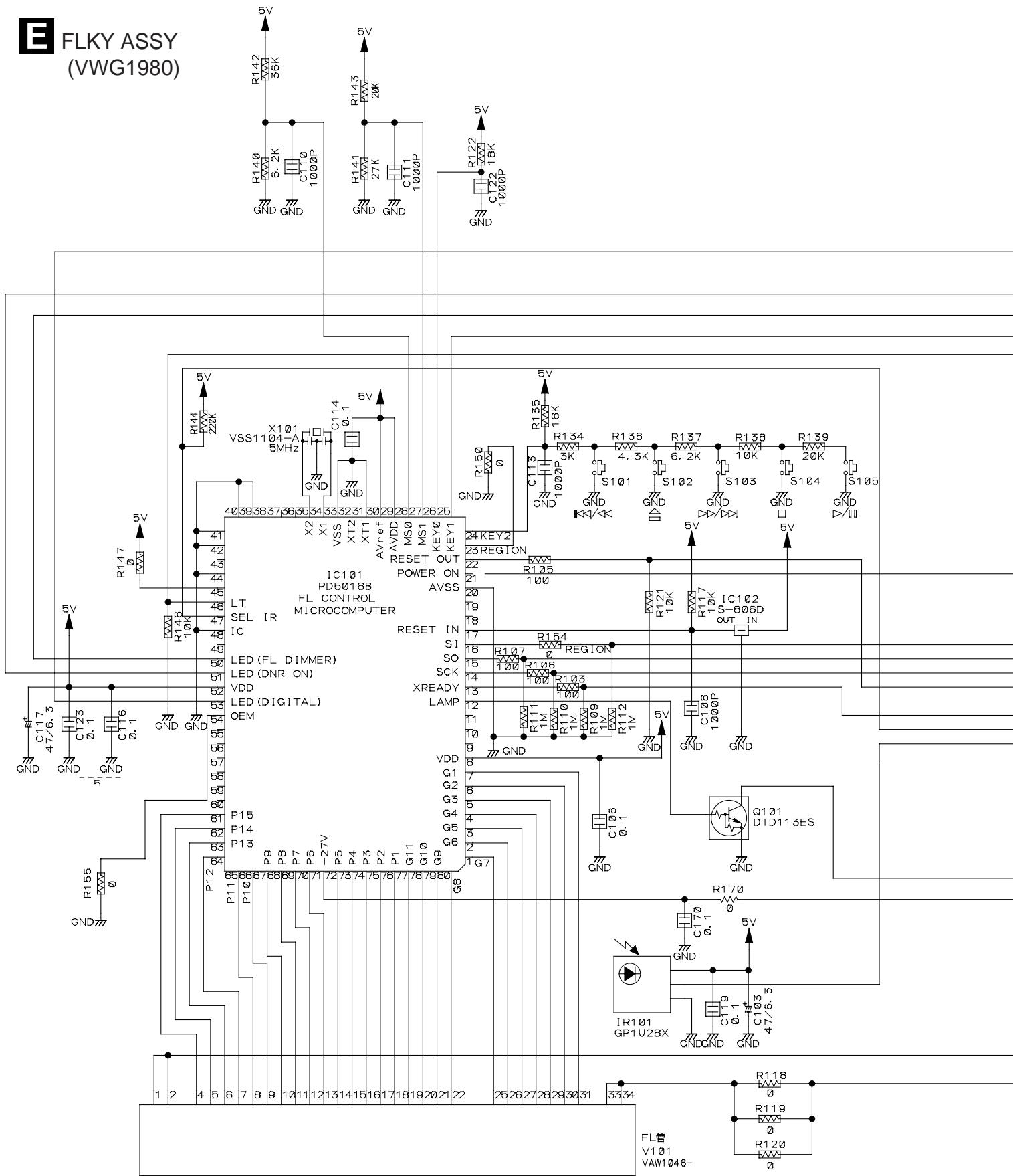

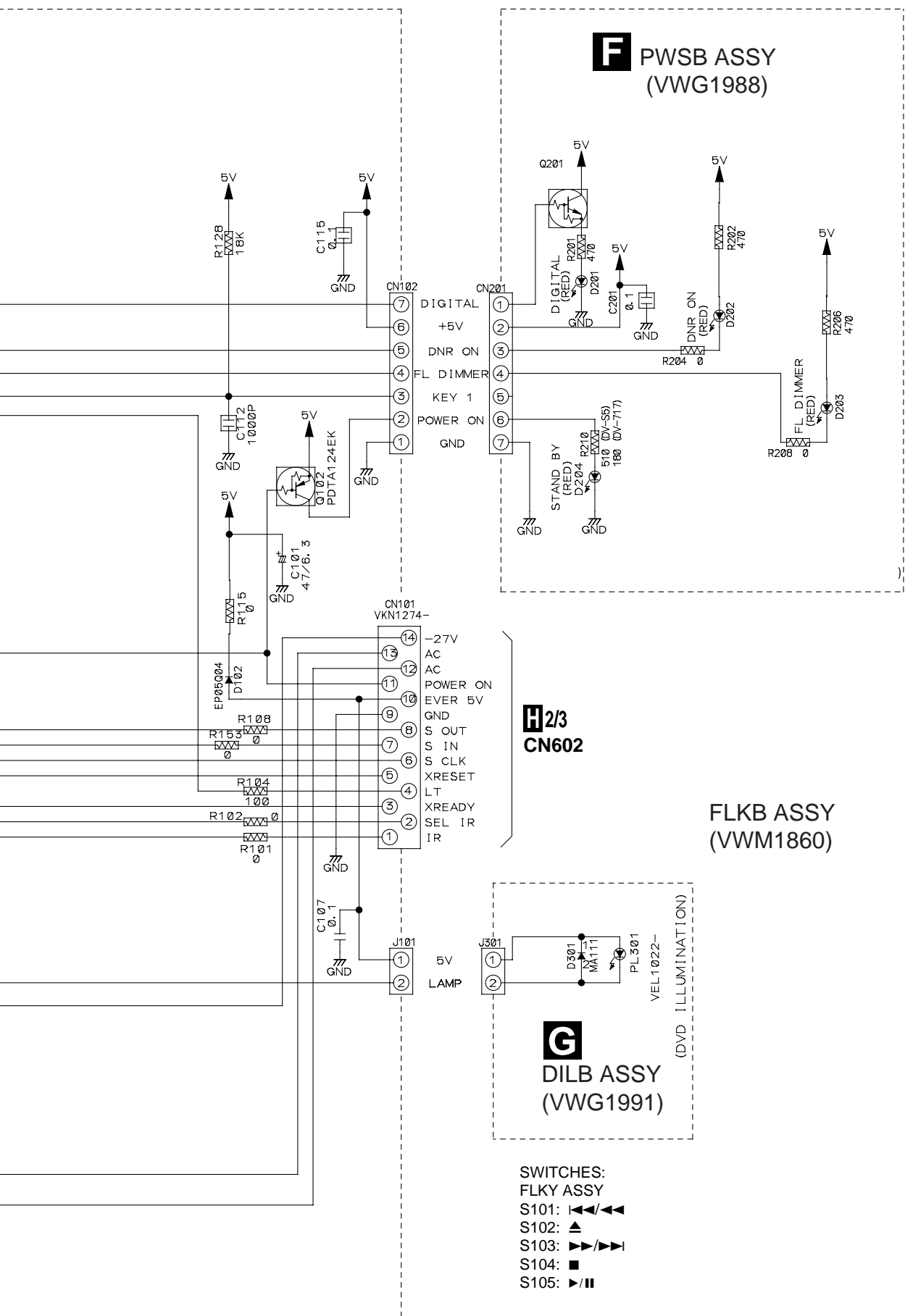

**2/3**  
**CN602**

- SWITCHES:**  
 FLKY ASSY  
 S101:   
 S102:   
 S103:   
 S104:   
 S105:













◁ : AUDIO SIGNAL ROUTE  
 ▀ : ROM DATA SIGNAL ROUTE

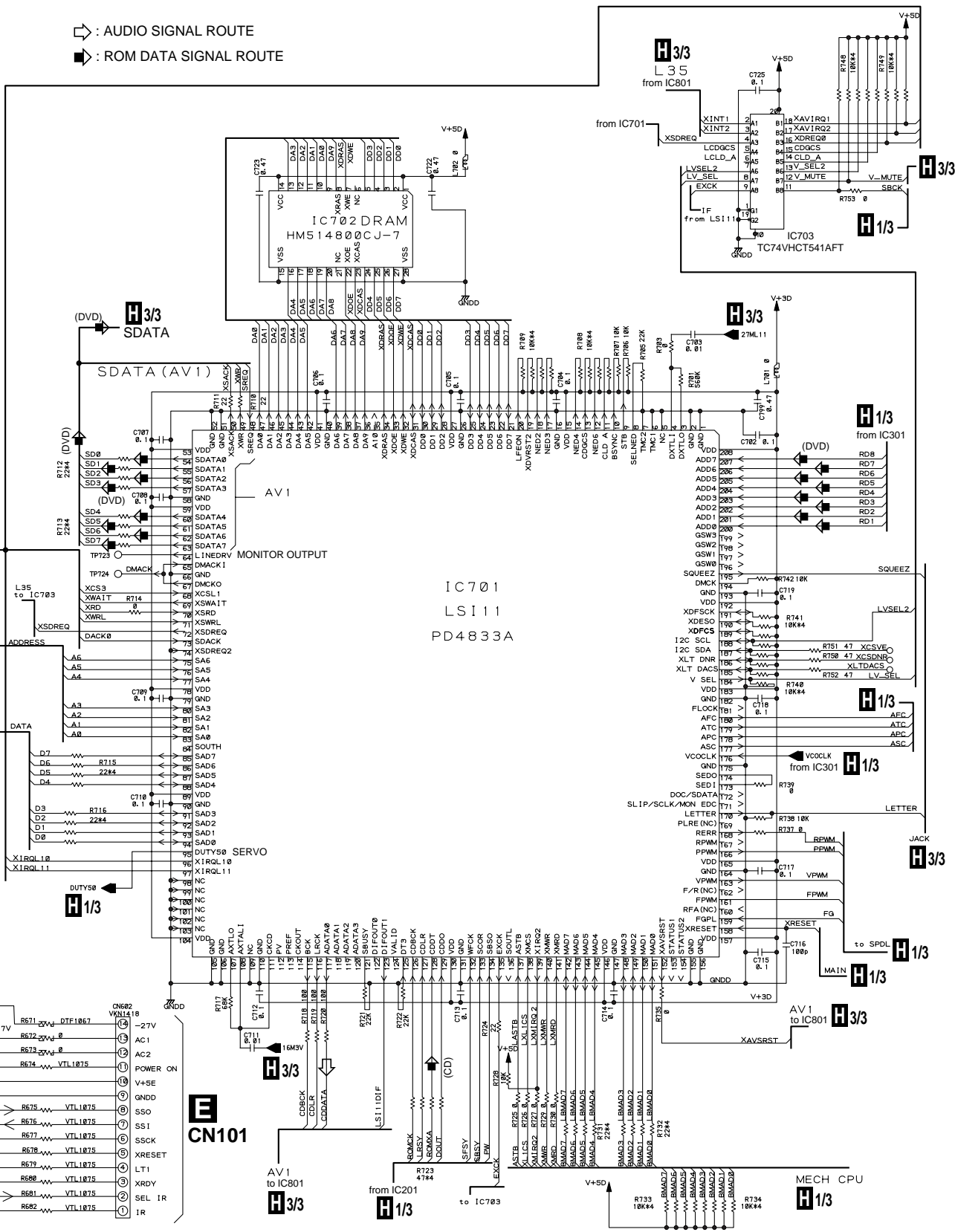

A

B

C

D

3.5 DVDM ASSY (3/3)

A

B

C

D

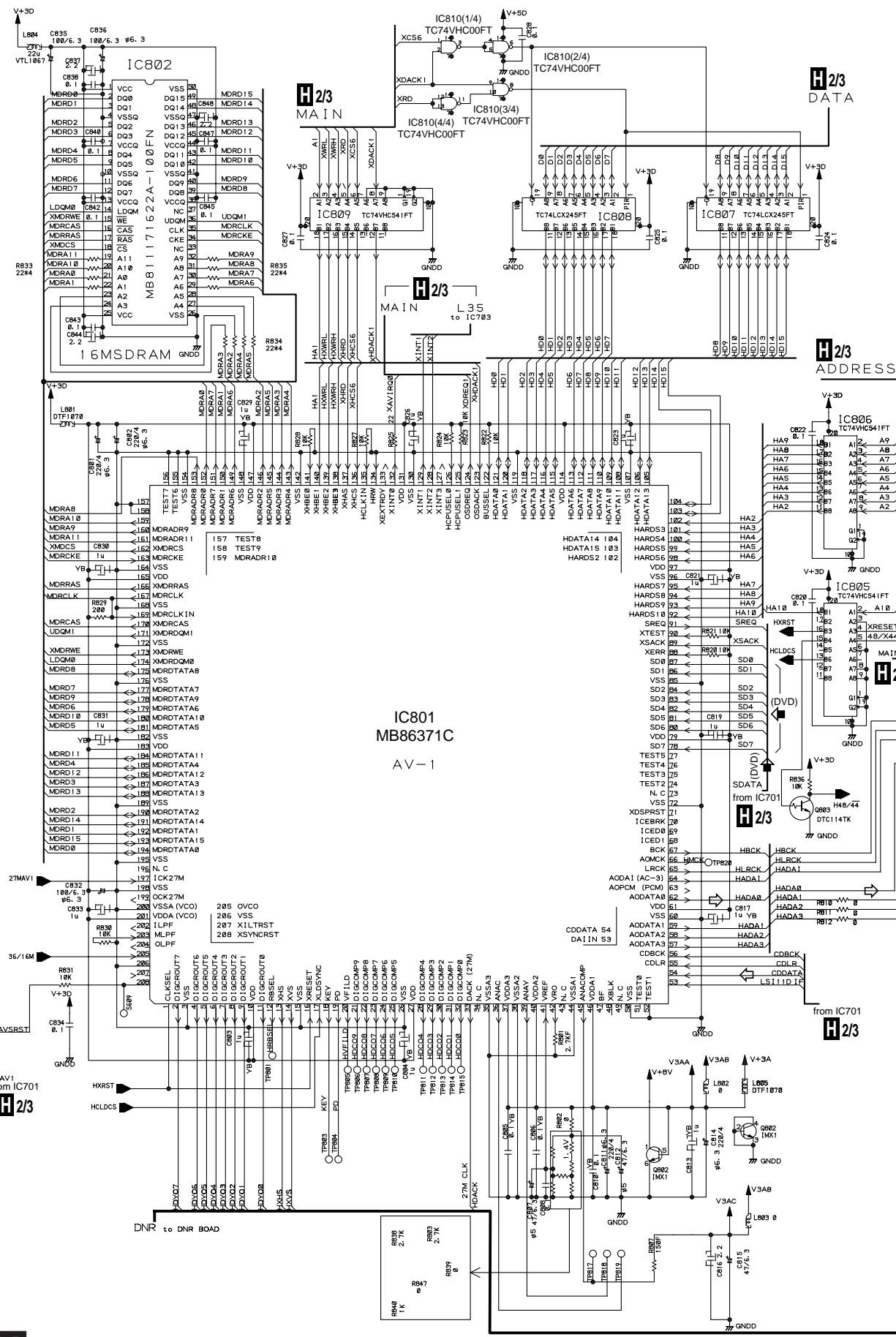



• WAVEFORMS OF DVDM ASSY

Note : (No.) in the table correspond to the number on the schematic diagram.

Measurement condition : No. 1 to 4 and 6 to 11 : Disc MJK1, Title 1-chp 1  
 No. 5 : CD, ABEX-784 Track 1  
 No. 13 to 14 : MJK1, Title 1-chp 4  
 No. 15 to 18 : MJK1, Title 1-chp 5

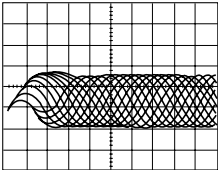
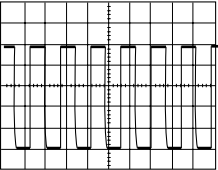
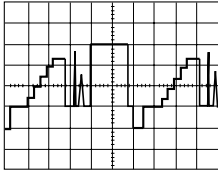
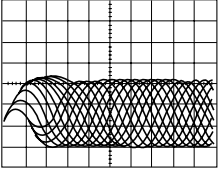
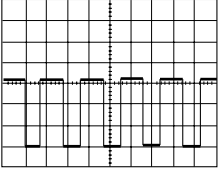
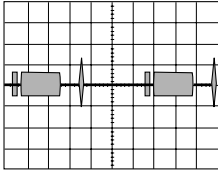
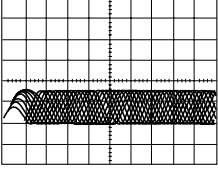
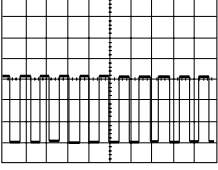
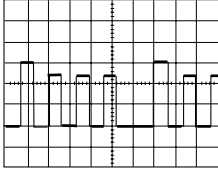
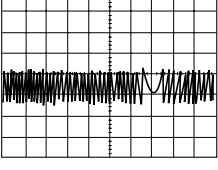
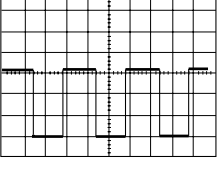
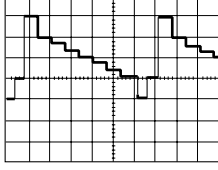
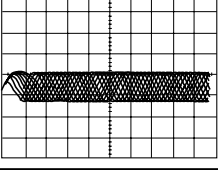
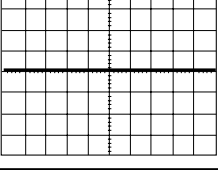
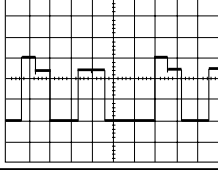
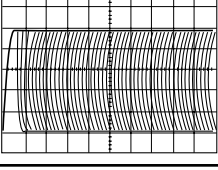
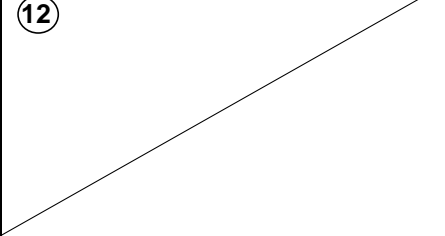
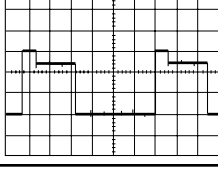
<p>① Q109-Emitter (RF) V: 100mV/div. H: 0.1<math>\mu</math>S/div.</p> 	<p>⑦ Q281-Collector (FG) V: 1V/div. H: 5mS/div.</p> 	<p>⑬ CN9031-pin 20 (Y output) V: 500mV/div. H: 10<math>\mu</math>S/div.</p> 
<p>② TP (RFO) V: 500mV/div. H: 0.1<math>\mu</math>S/div.</p> 	<p>⑧ Foot of R261 (FPWM) V: 1V/div. H: 10<math>\mu</math>S/div.</p> 	<p>⑭ CN9031-pin 18 (C output) V: 500mV/div. H: 10<math>\mu</math>S/div.</p> 
<p>③ IC301-pin 19 (RF for A/D converter) V: 1V/div. H: 0.2<math>\mu</math>S/div.</p> 	<p>⑨ Foot of R262 (VPWM) V: 1V/div. H: 10<math>\mu</math>S/div.</p> 	<p>⑮ CN9031-pin 6 (B output when selecting color difference output) V: 500mV/div. H: 10<math>\mu</math>S/div.</p> 
<p>④ TP (Tracking Error) V: 1V/div. H: 2mS/div.</p> 	<p>⑩ Foot of R263 (PPWM) V: 1V/div. H: 0.2<math>\mu</math>S/div.</p> 	<p>⑯ CN9031-pin 20 (Y output when selecting color difference output) V: 500mV/div. H: 10<math>\mu</math>S/div.</p> 
<p>⑤ IC201-pin 39 (EFM before slice) V: 1V/div. H: 1<math>\mu</math>S/div.</p> 	<p>⑪ Foot of R264 (RPWM) V: 1V/div. H: 10<math>\mu</math>S/div.</p>  <p style="text-align: right;">DC1.4V</p>	<p>⑰ CN9031-pin 2 (R output when selecting color difference output) V: 500mV/div. H: 10<math>\mu</math>S/div.</p> 
<p>⑥ IC201-pin 1 (EFM) V: 1V/div. H: 0.2<math>\mu</math>S/div.</p> 	<p>⑫</p> 	<p>⑱ CN9031-pin 4 (G output when selecting color difference output) V: 500mV/div. H: 10<math>\mu</math>S/div.</p> 



3.6 AVJB ASSY (1/2)

A

H3/3  
CN9020

B

C

D

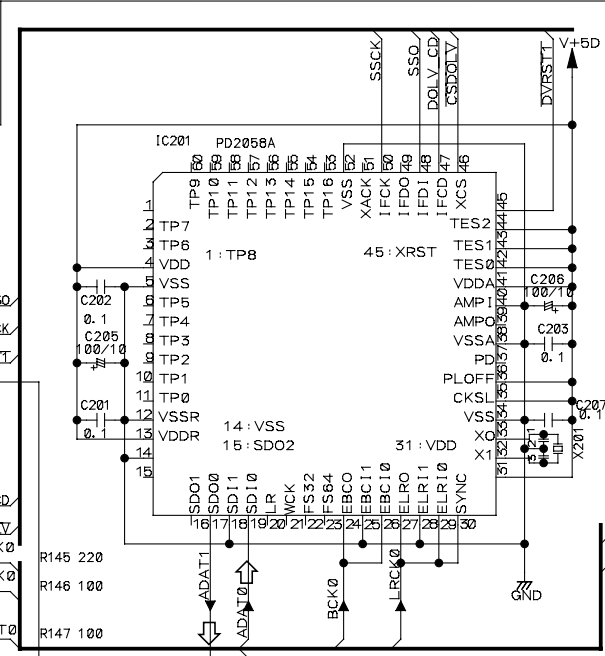
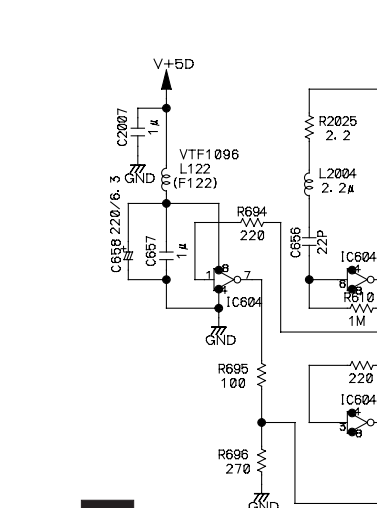
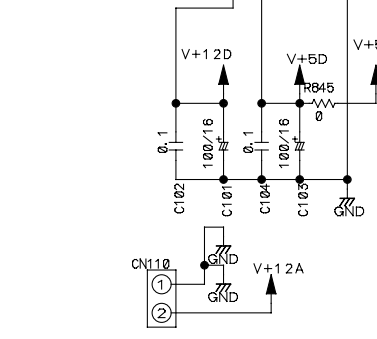
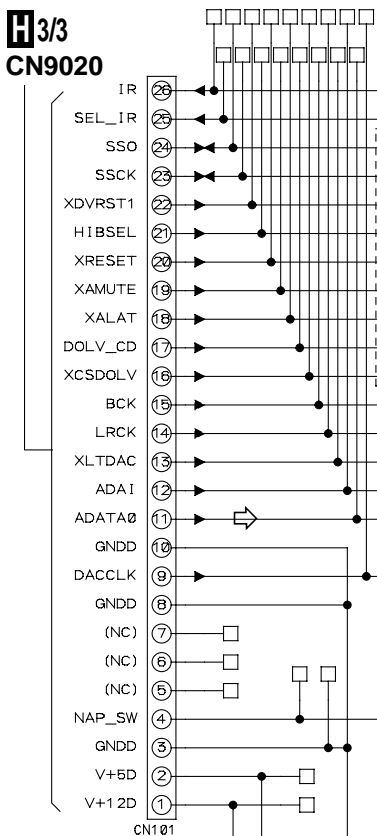

HBSSEL	HiBit
H	ON
L	OFF

# 1/2 AVJB ASSY(1/2) (VWV1617)

⇒ : AUDIO SIGNAL ROUTE

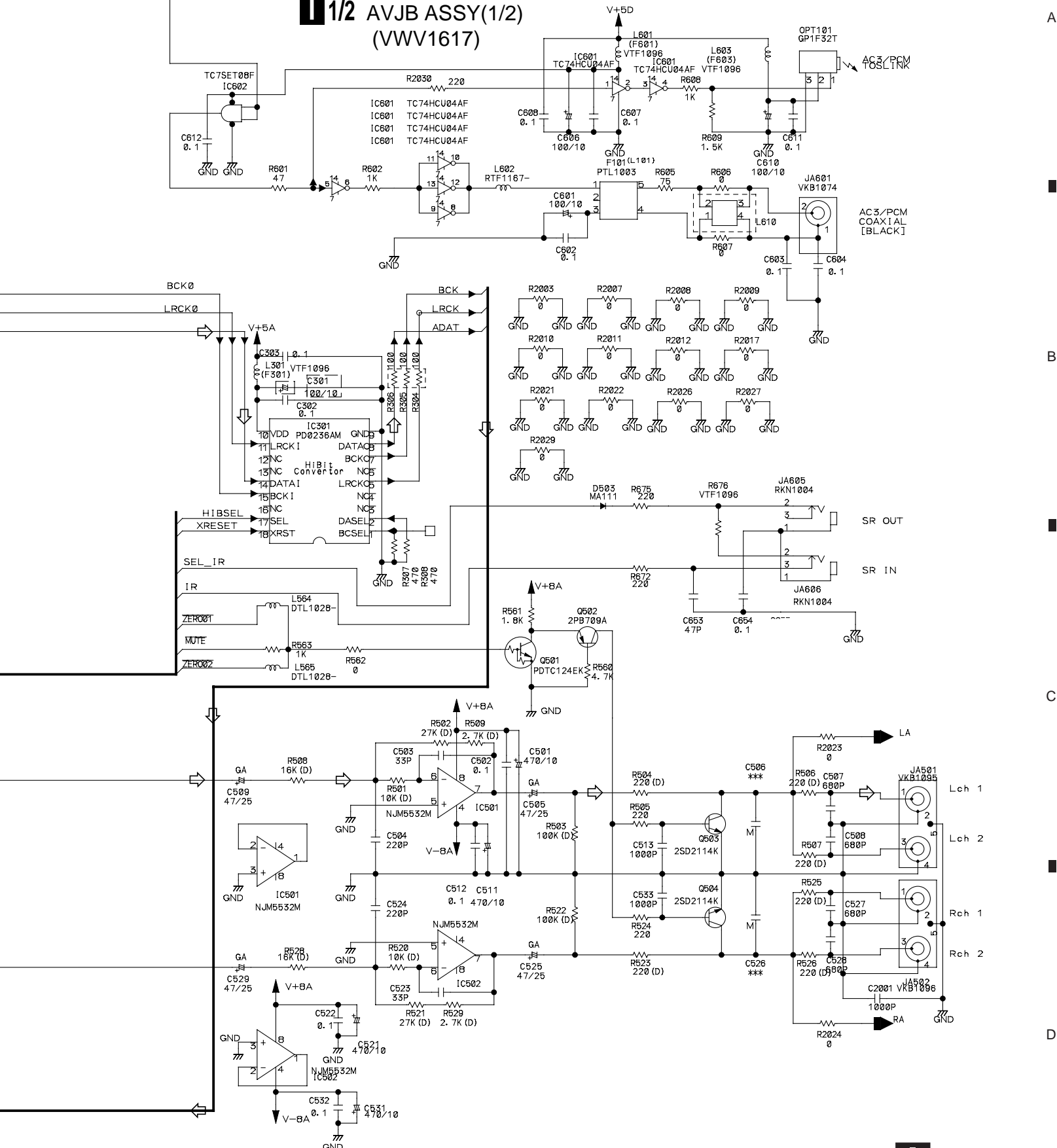

3.7 AVJB ASSY (2/2)

A

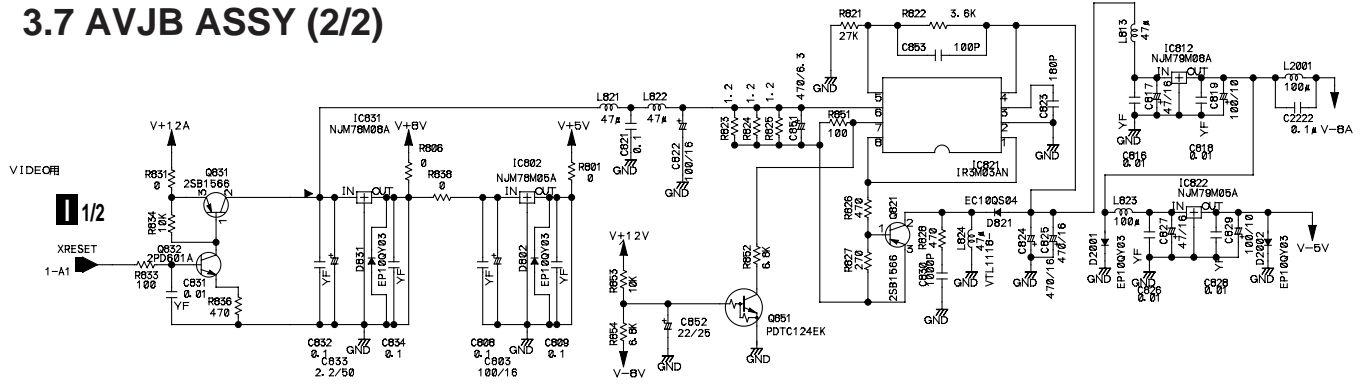

B

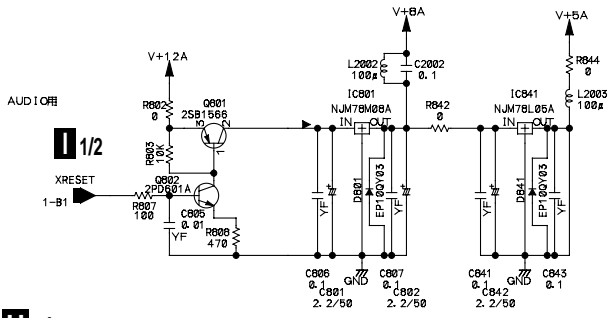



VSEL1 (BLANK)	H	L
VSEL2	(H)	H L
OUTPUT	RGB, V	V S

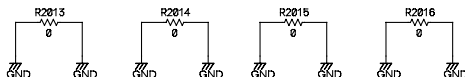
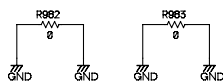

- (V/CB) : V/CB SIGNAL ROUTE
- (Y) : Y SIGNAL ROUTE
- (C) : C SIGNAL ROUTE

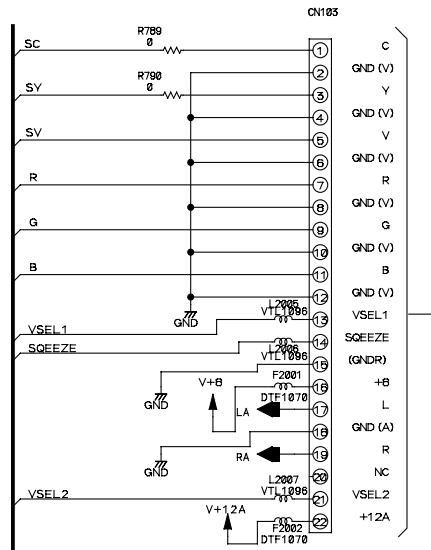

**K**  
CN1001

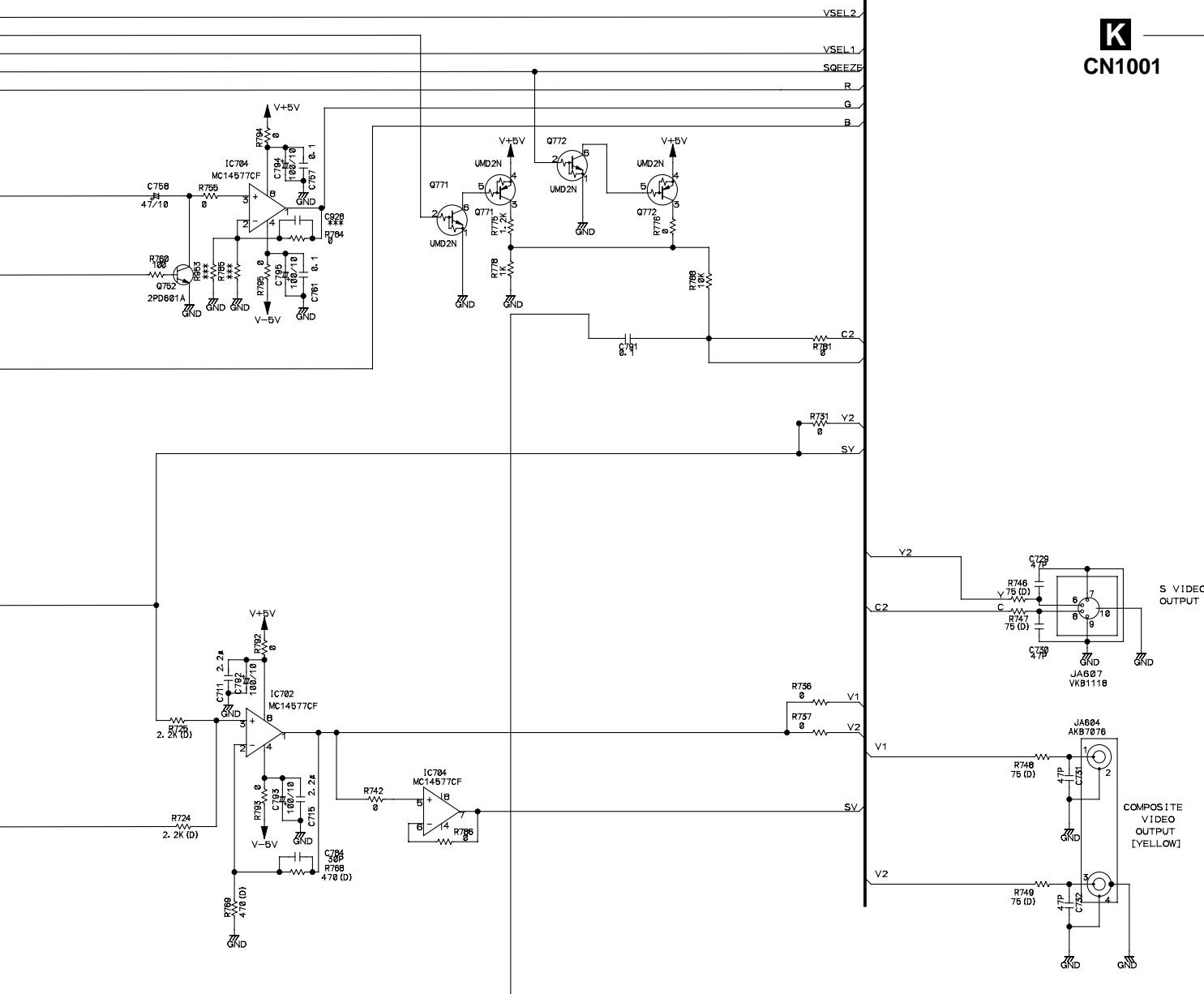

3.8 DNRB ASSY (1/2)

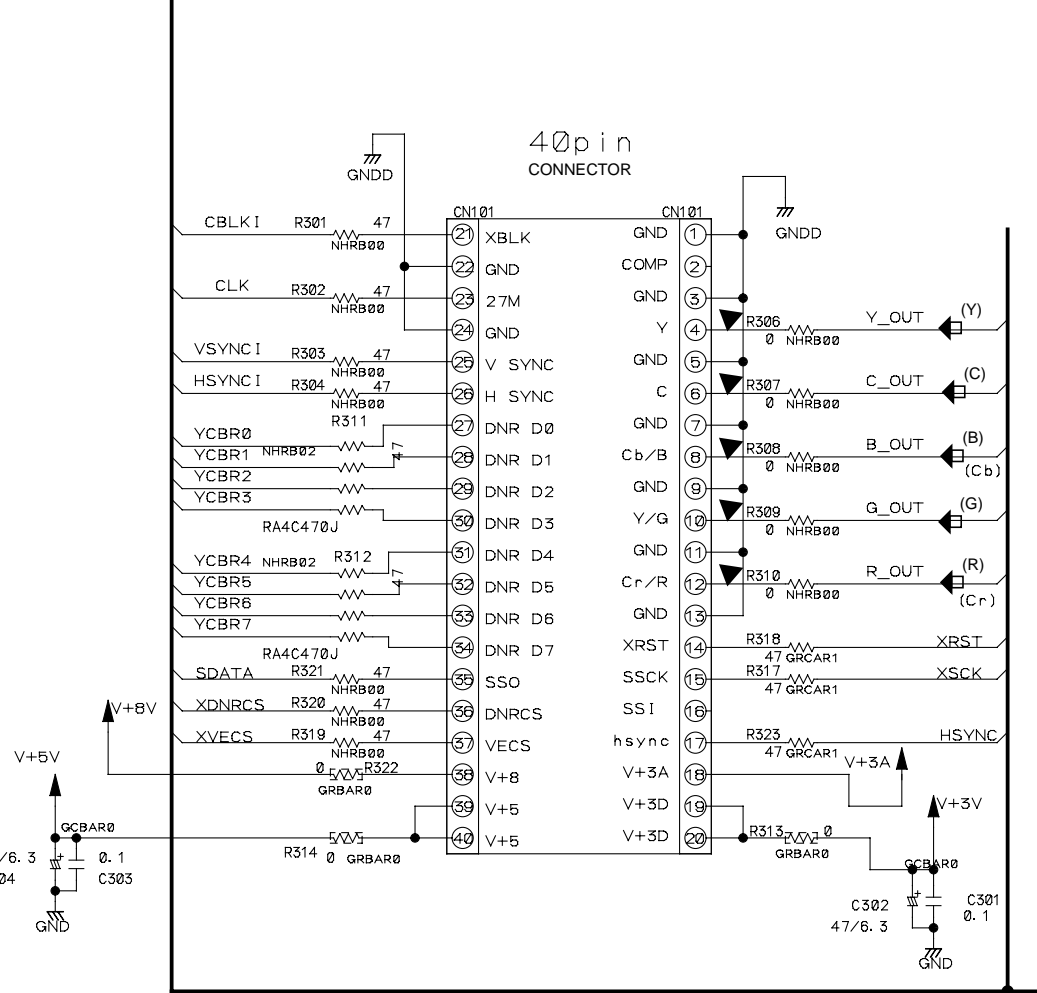
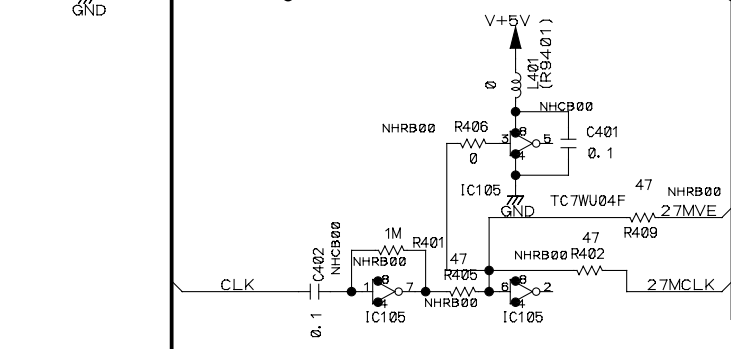
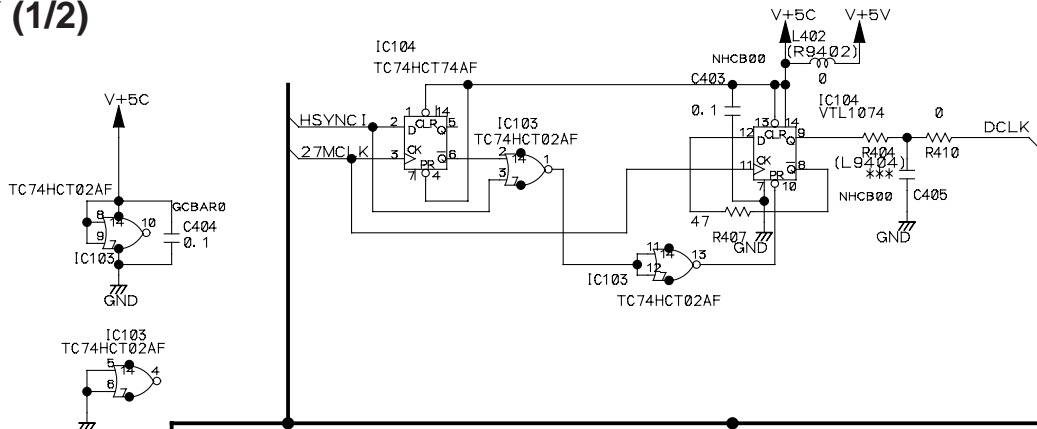



3.9 DNRB ASSY (2/2)

J 2/2  
DNRB ASSY(2/2)  
(VWV1619)

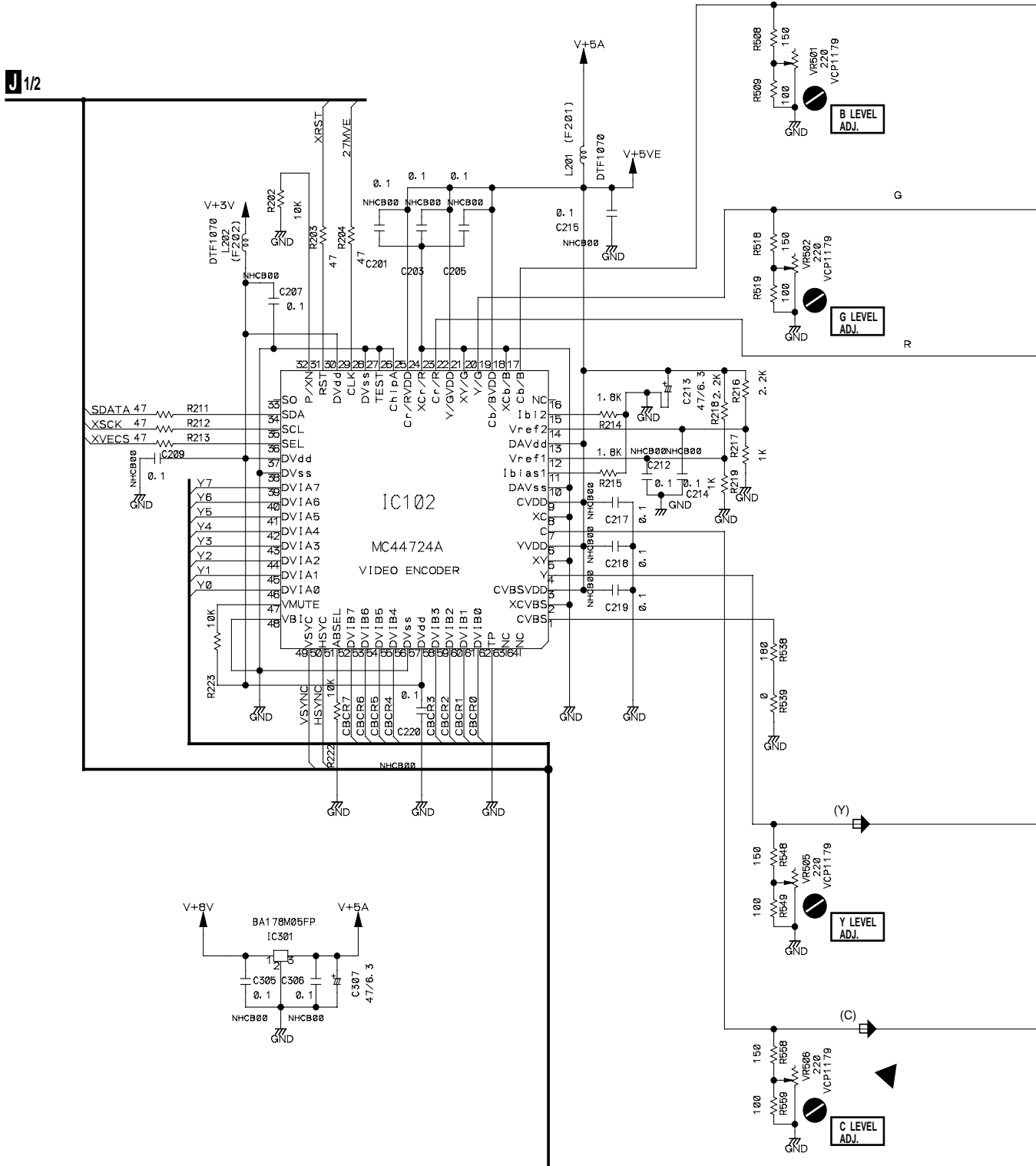

- (R) : R SIGNAL ROUTE
- (G) : G SIGNAL ROUTE
- (B) : B SIGNAL ROUTE
- (Y) : Y SIGNAL ROUTE
- (C) : C SIGNAL ROUTE

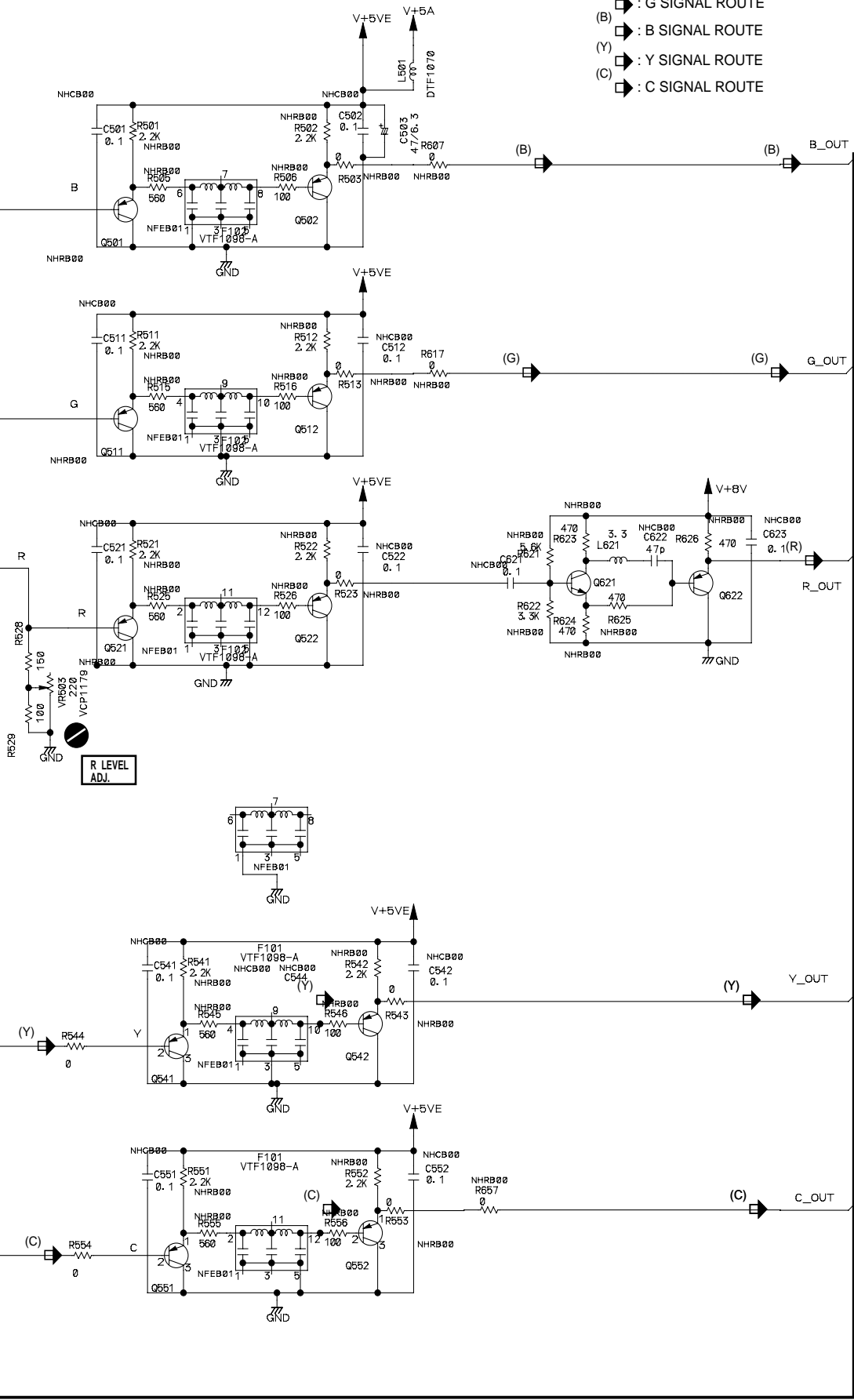

A

B

C

D

3.10 SCRIB ASSY

**K** SCRIB ASSY (VWV1623)

2/2  
CN103

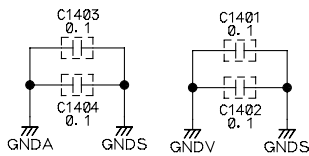
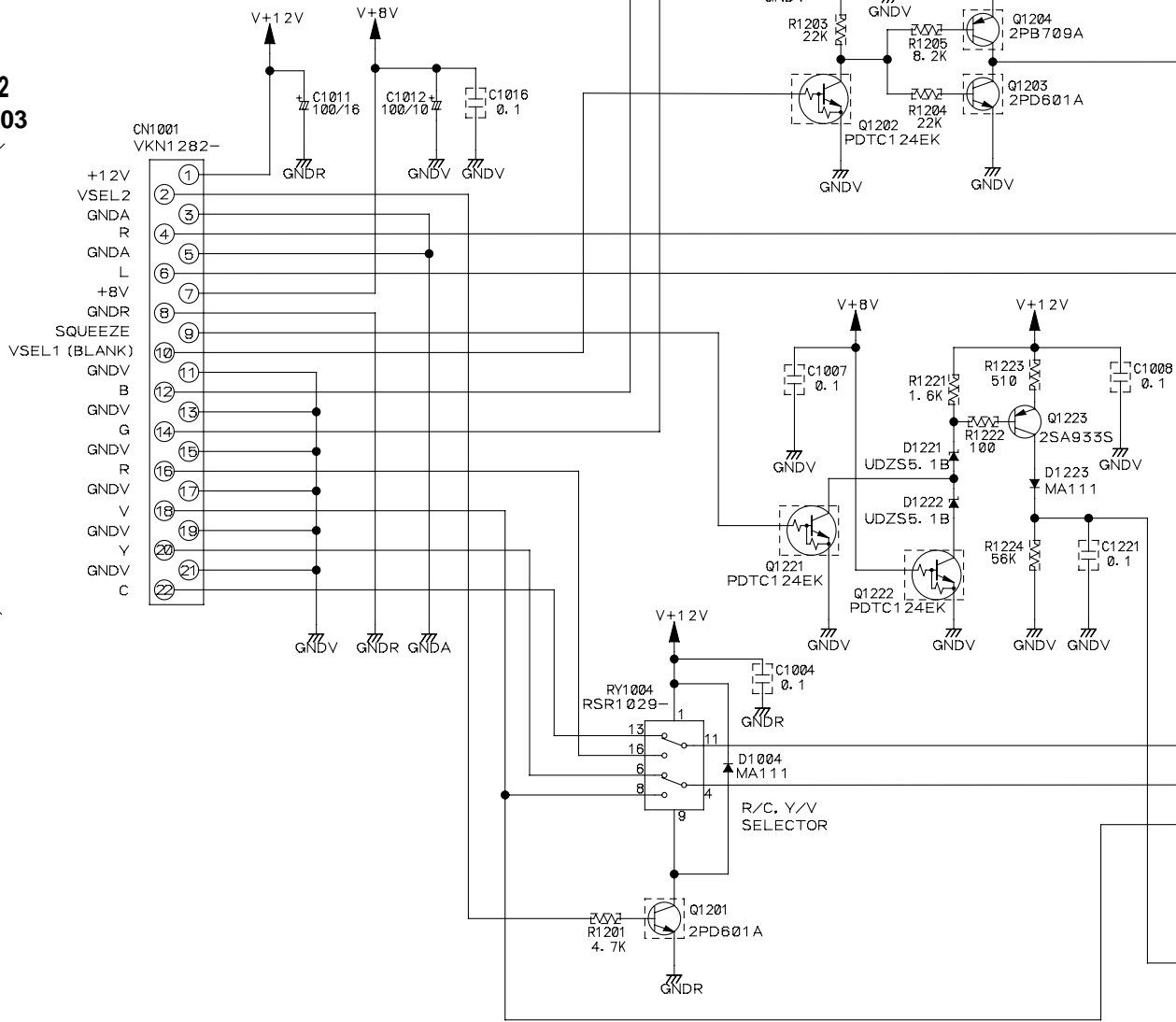

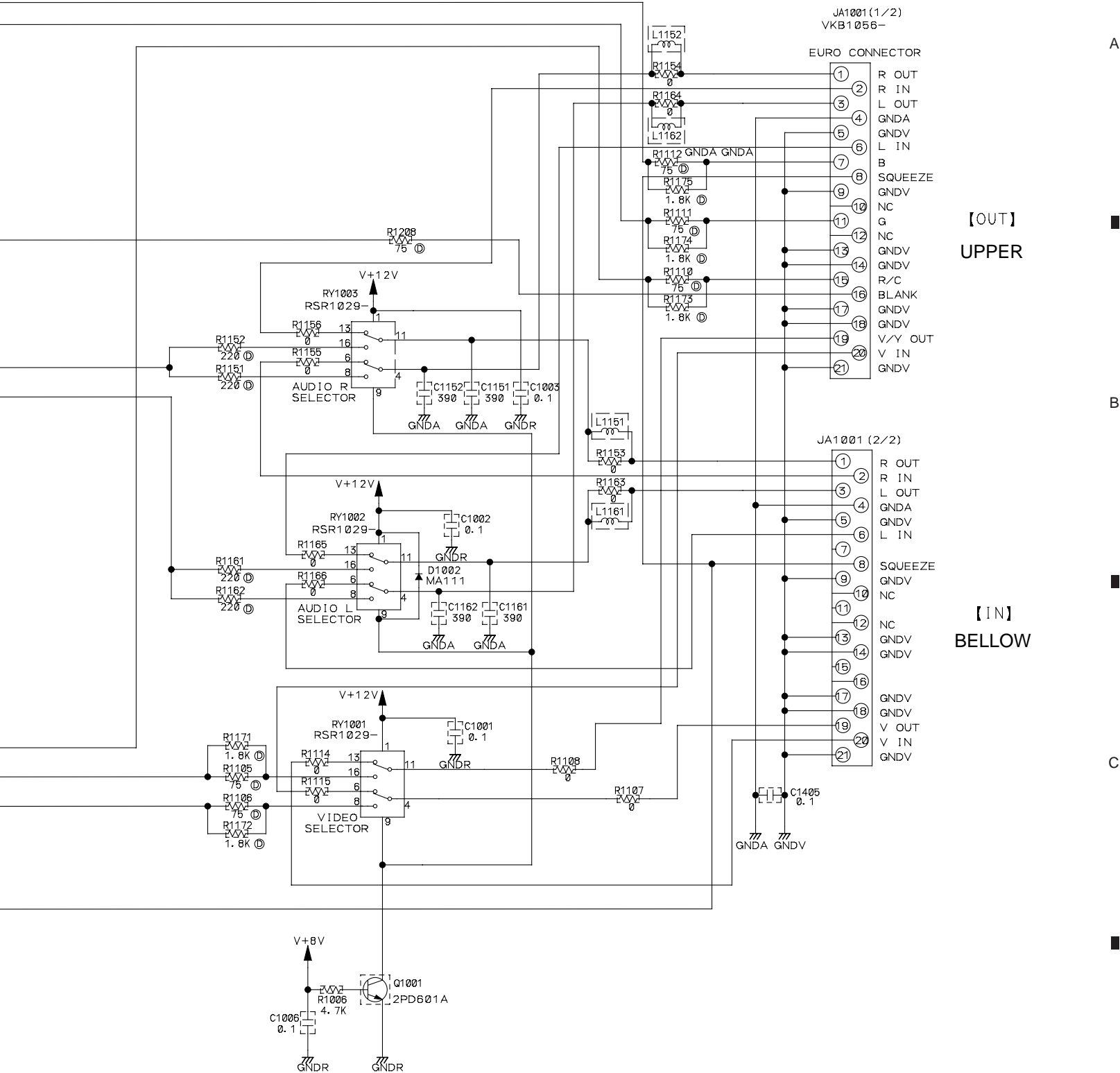

【OUT】  
UPPER

【IN】  
BELOW



3.11 POWER SUPPLY ASSY and MSWB ASSY

1/3 CN110

POWER SUPPLY ASSY (VWR1306)

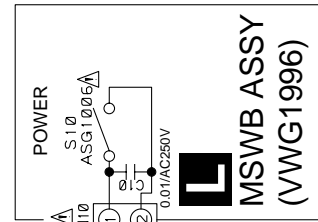
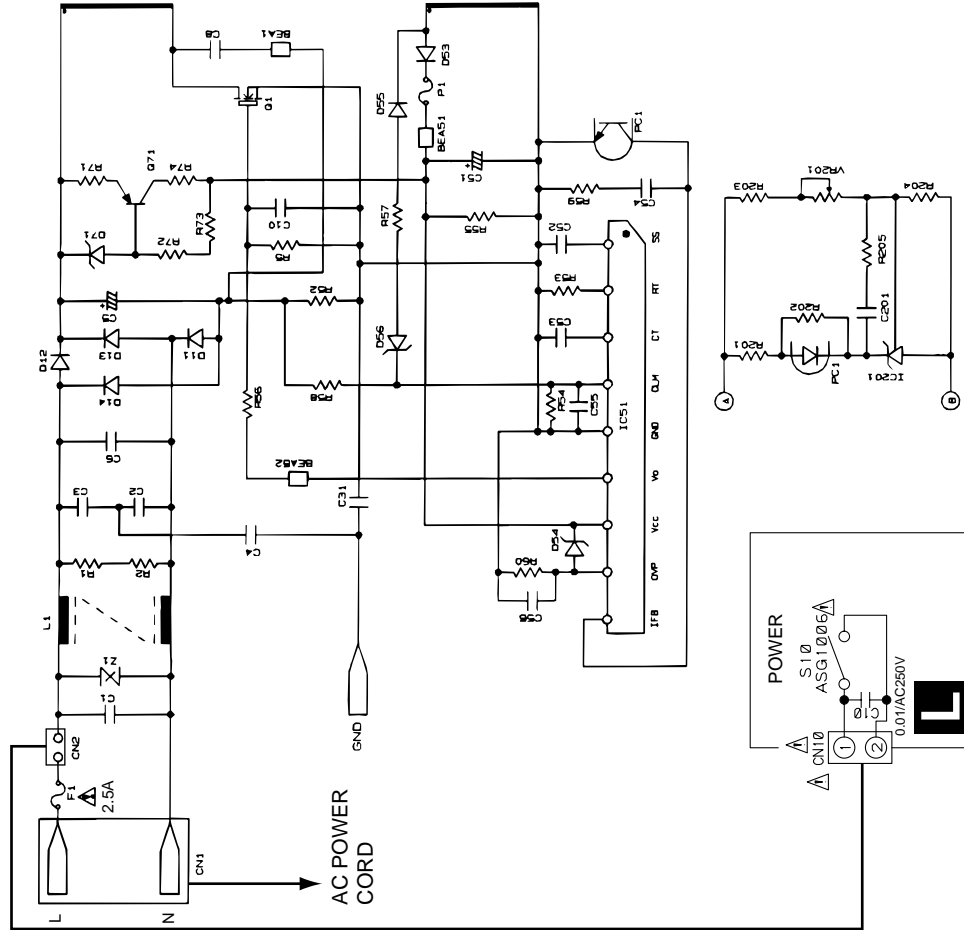
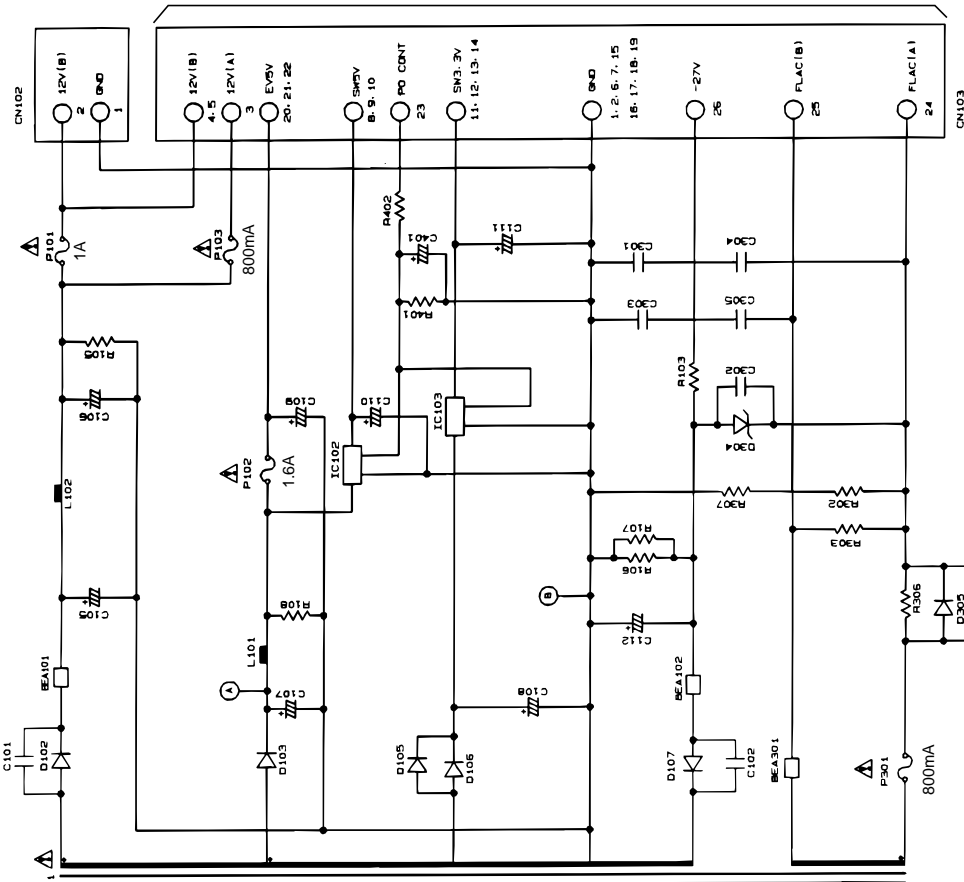

MSWB ASSY (VWG1996)





# 4. PCB CONNECTION DIAGRAM

## NOTE FOR PCB DIAGRAMS :

1. Part numbers in PCB diagrams match those in the schematic diagrams.
2. A comparison between the main parts of PCB and schematic diagrams is shown below.

Symbol In PCB Diagrams	Symbol In Schematic Diagrams	Part Name
		Transistor
		Transistor with resistor
		Field effect transistor
		Resistor array
		3-terminal regulator

3. The parts mounted on this PCB include all necessary parts for several destinations.  
For further information for respective destinations, be sure to check with the schematic diagram.
4. View point of PCB diagrams.

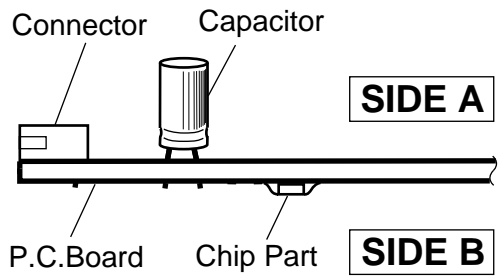

## 4.1 LOMB, LOSB, SMEB and FGSB ASSEMBLIES

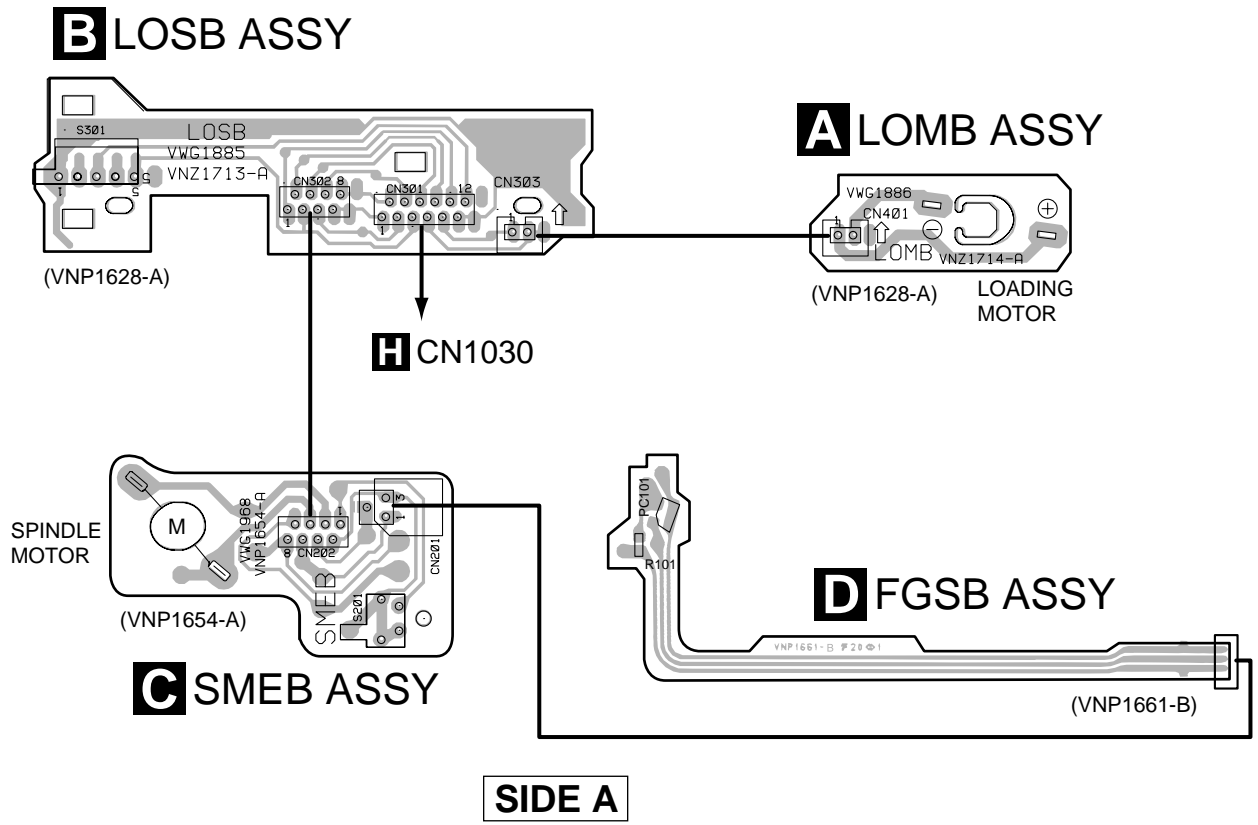

### 4.2 FLKY, PWSB and DIRB ASSEMBLIES

#### **F** PWSB ASSY

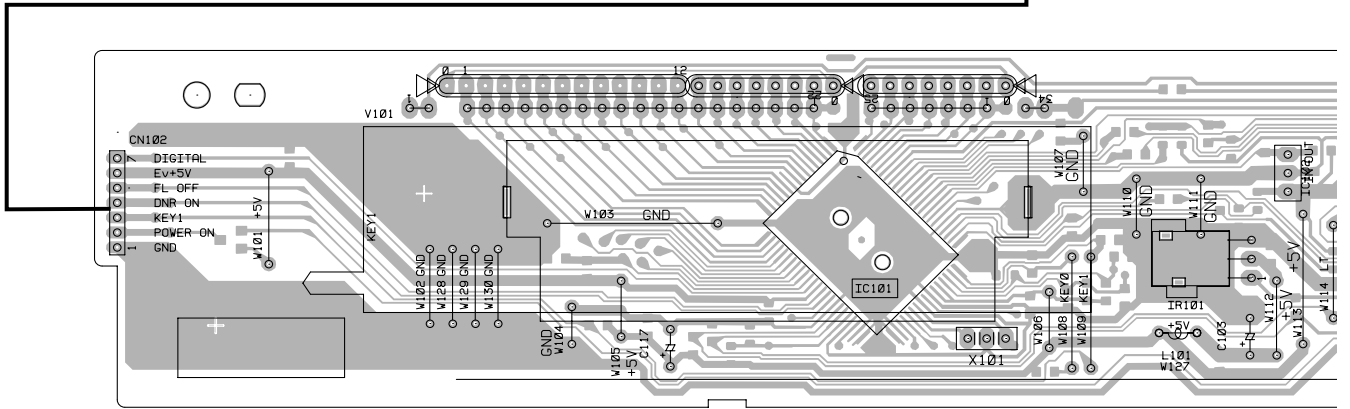
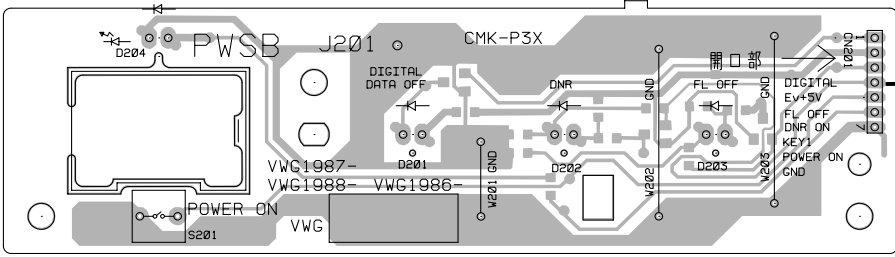

IC102

#### **G** DIRB ASSY

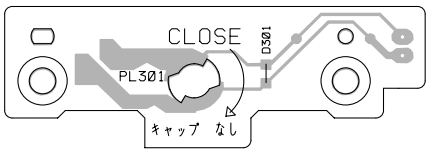

#### **E** FLKY ASSY

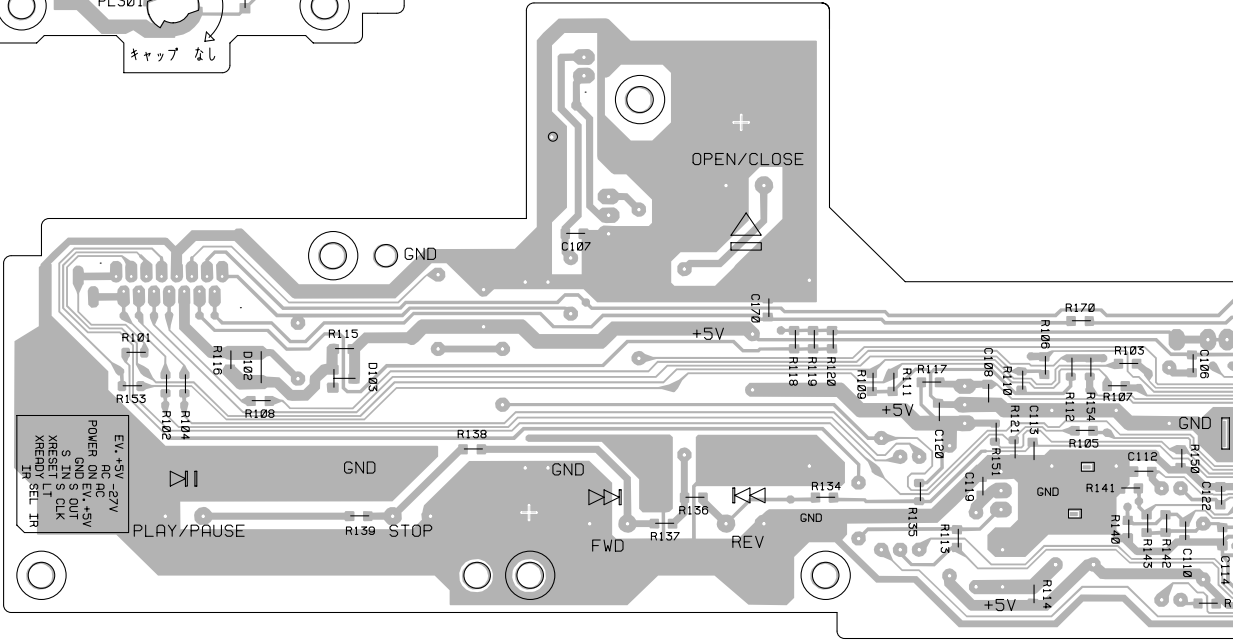

# G DIRB ASSY

SIDE A

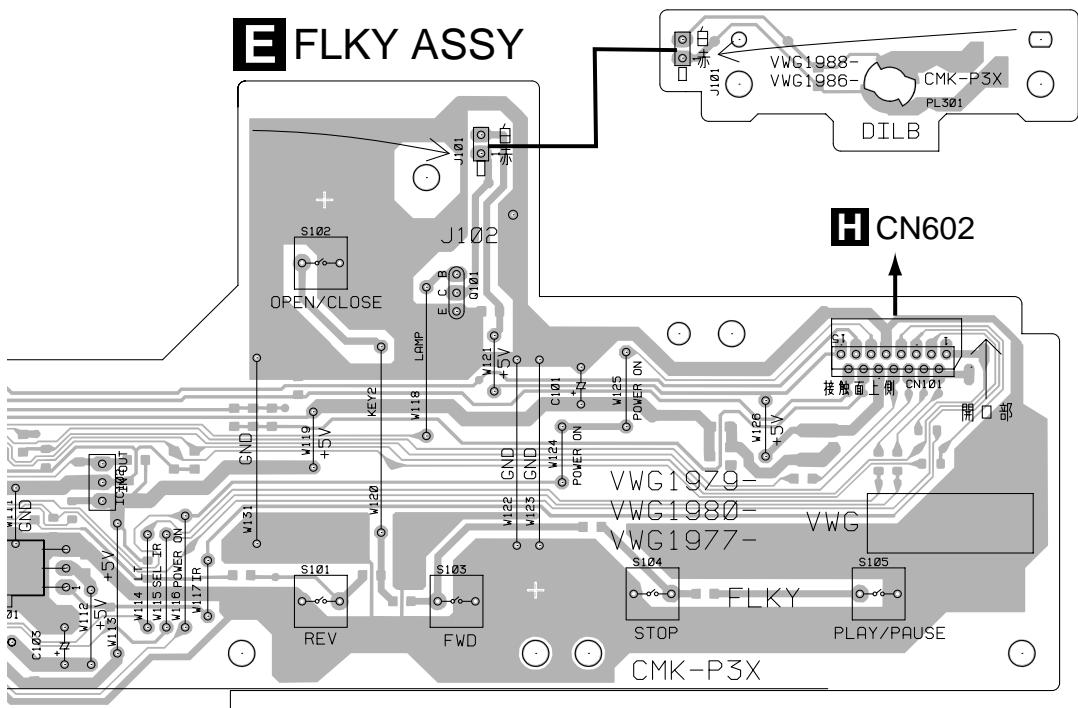

(VNP1656-B)

IC102

Q101

# F PWSB ASSY

SIDE B

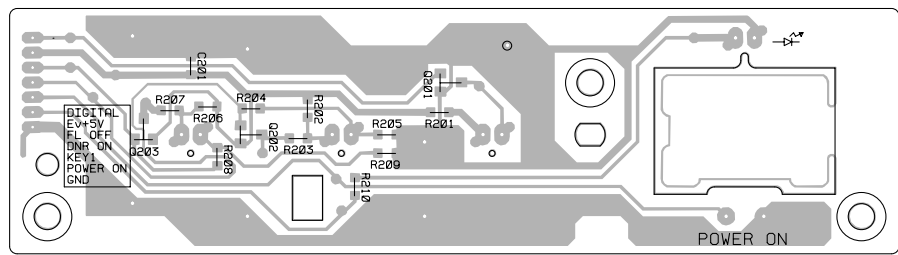

Q203

Q202

Q201

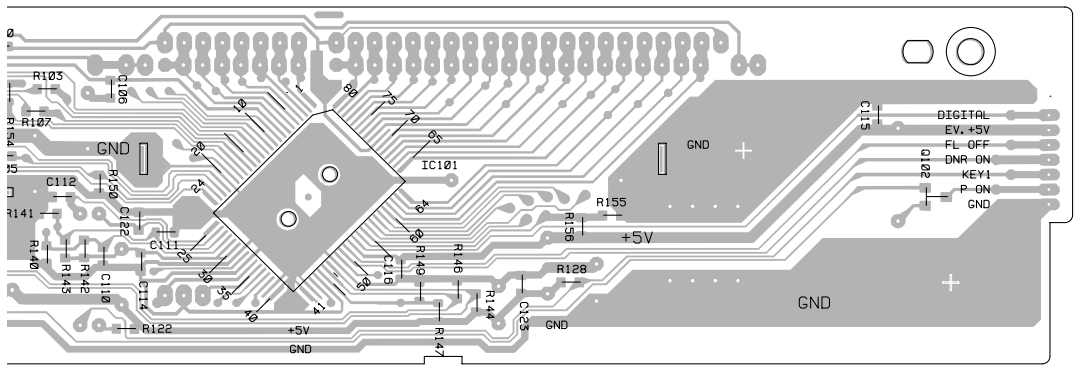

(VNP1656-B)

IC101

Q102



### 4.3 DVDM ASSY

• This PCB is a four-layered board. Middle layer is mainly connected to Vcc and GND.

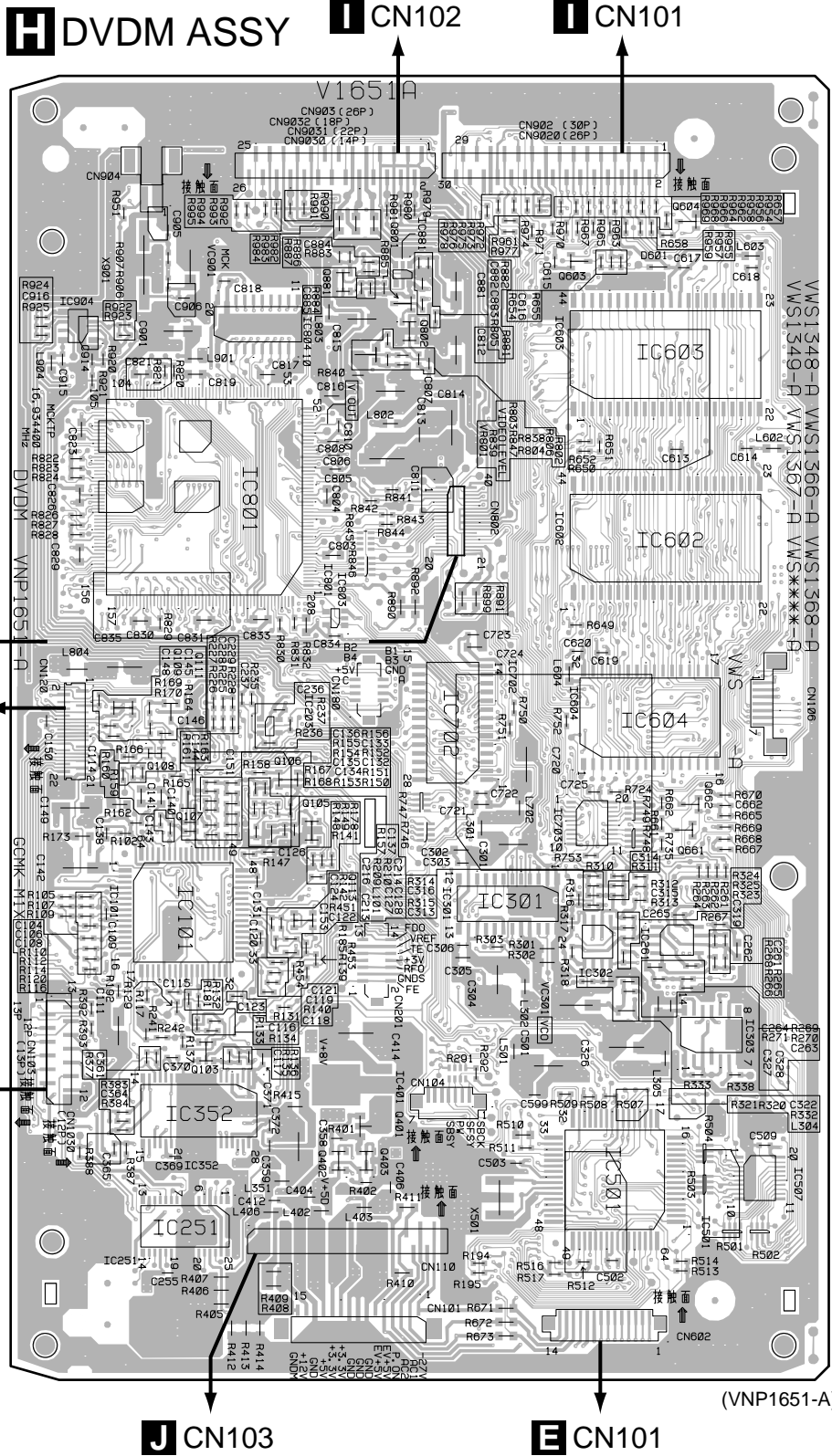

- Q604
- IC881
- Q881 Q603
- IC904 IC804 Q801
- Q914 Q802 IC603
- VR801
- IC801
- IC602
- IC803
- Q109 IC702 IC604
- Q111 IC203
- Q108 Q106
- Q107 Q105 IC703
- Q662 Q661
- IC101 IC301
- Q113 IC261
- IC302
- VC301
- Q103 IC303
- IC401
- IC352 Q401
- Q402 Q403
- IC507
- IC501
- IC251



• This PCB is a four-layered board. Middle layer is mainly connected to Vcc and GND.

# H DVDM ASSY

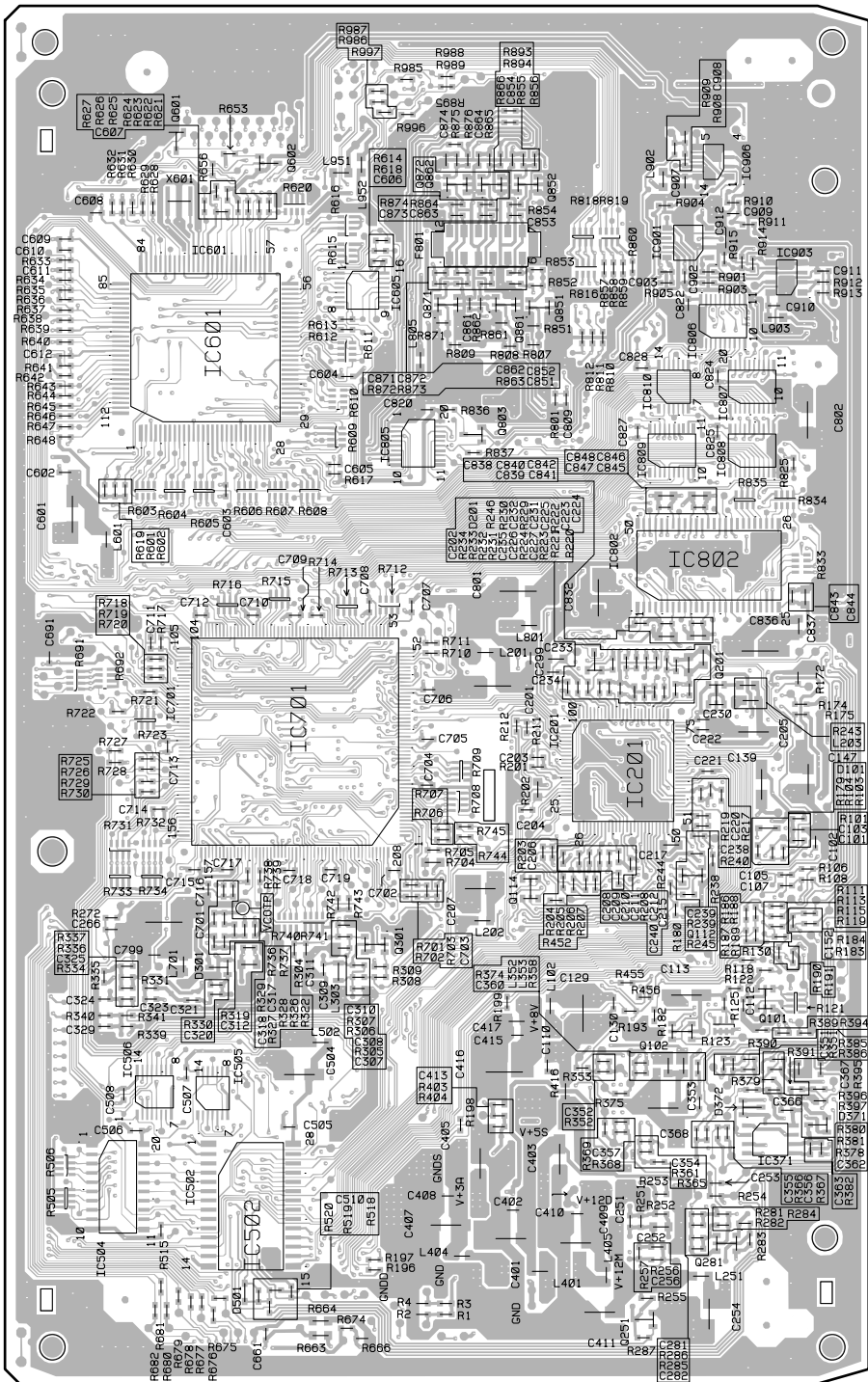

- Q601 Q602 IC906
- Q872 Q862 Q852
- IC901 IC903
- IC605
- Q871 Q861 Q851
- IC601 IC806
- IC810 IC807
- IC805 Q803
- IC809 IC808
- IC802
- Q201
- IC701
- IC201
- Q114 Q112
- Q301
- Q101
- Q102
- IC506 IC505
- IC371
- IC504
- IC502 Q281
- Q251

(VNP1651-A)

**SIDE B**







SIDE A

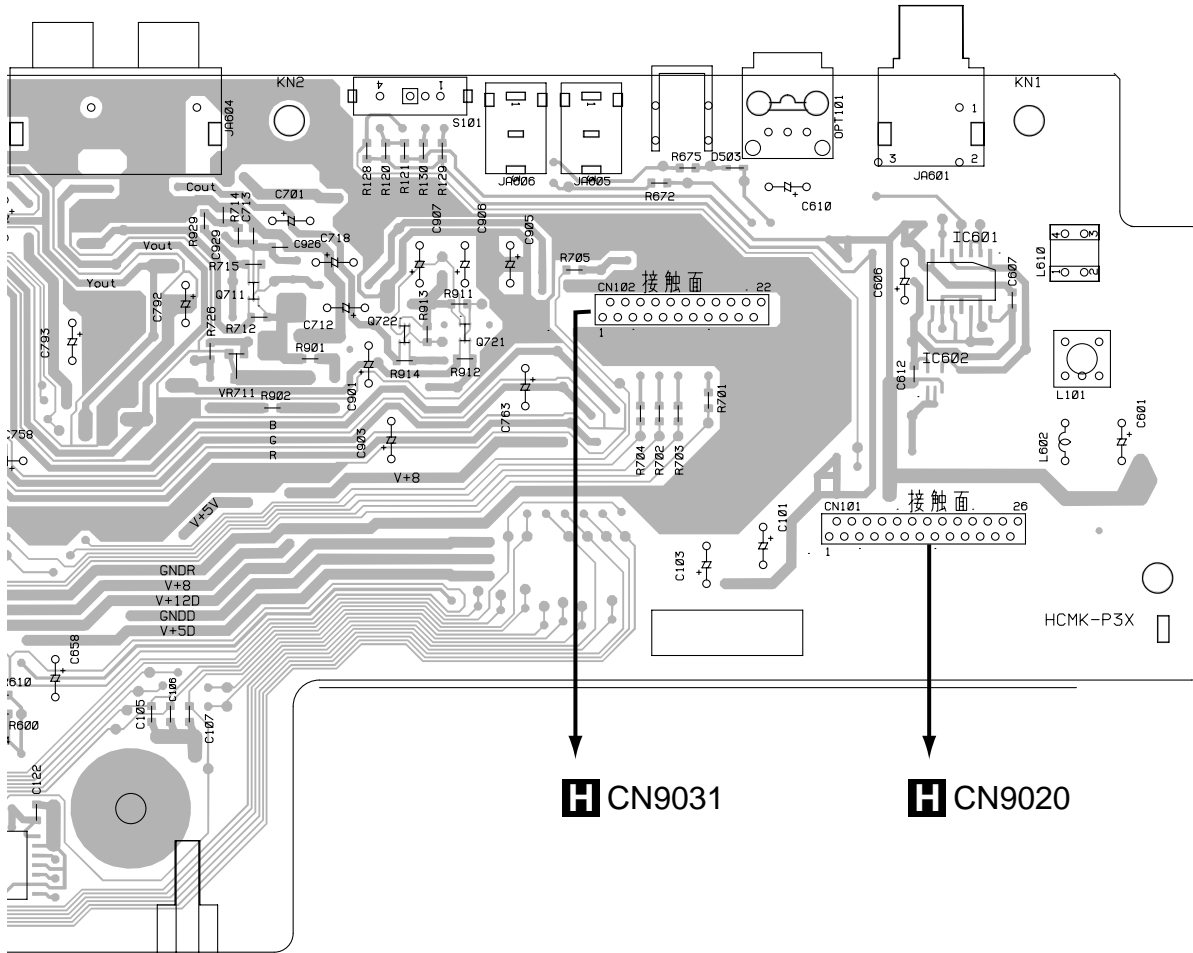

**H** CN9031

**H** CN9020

(VNP1658-A)

:102 Q711 Q722 Q721

IC601  
IC602

# AVJB ASSY

Q901 Q902 IC702 IC604 Q921 C IC704

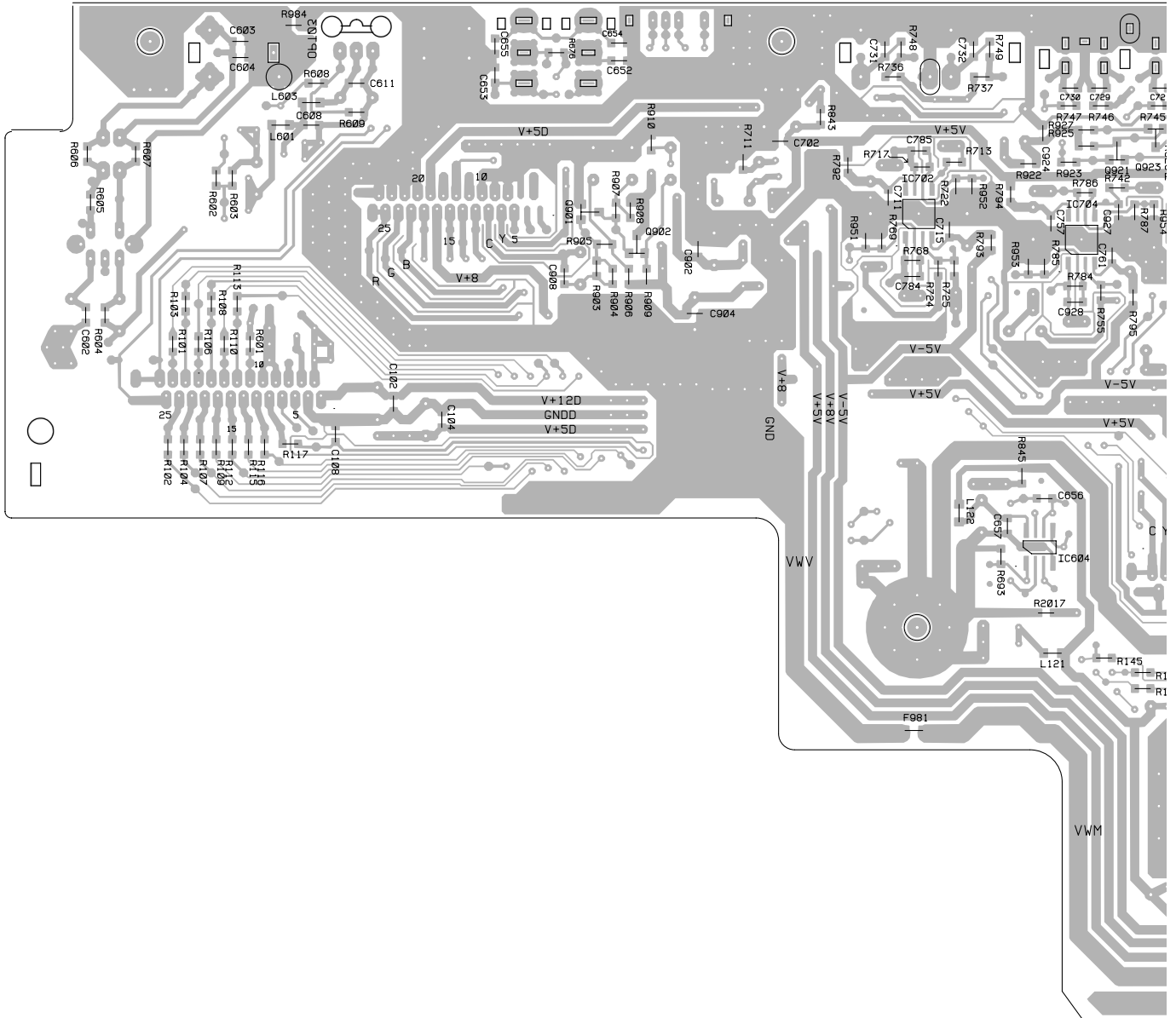



**SIDE B**

C604 Q921 Q923 Q922  
IC704 IC706

Q504

Q802 Q803  
Q832 Q833

IC501 Q503  
IC602 Q501 Q502

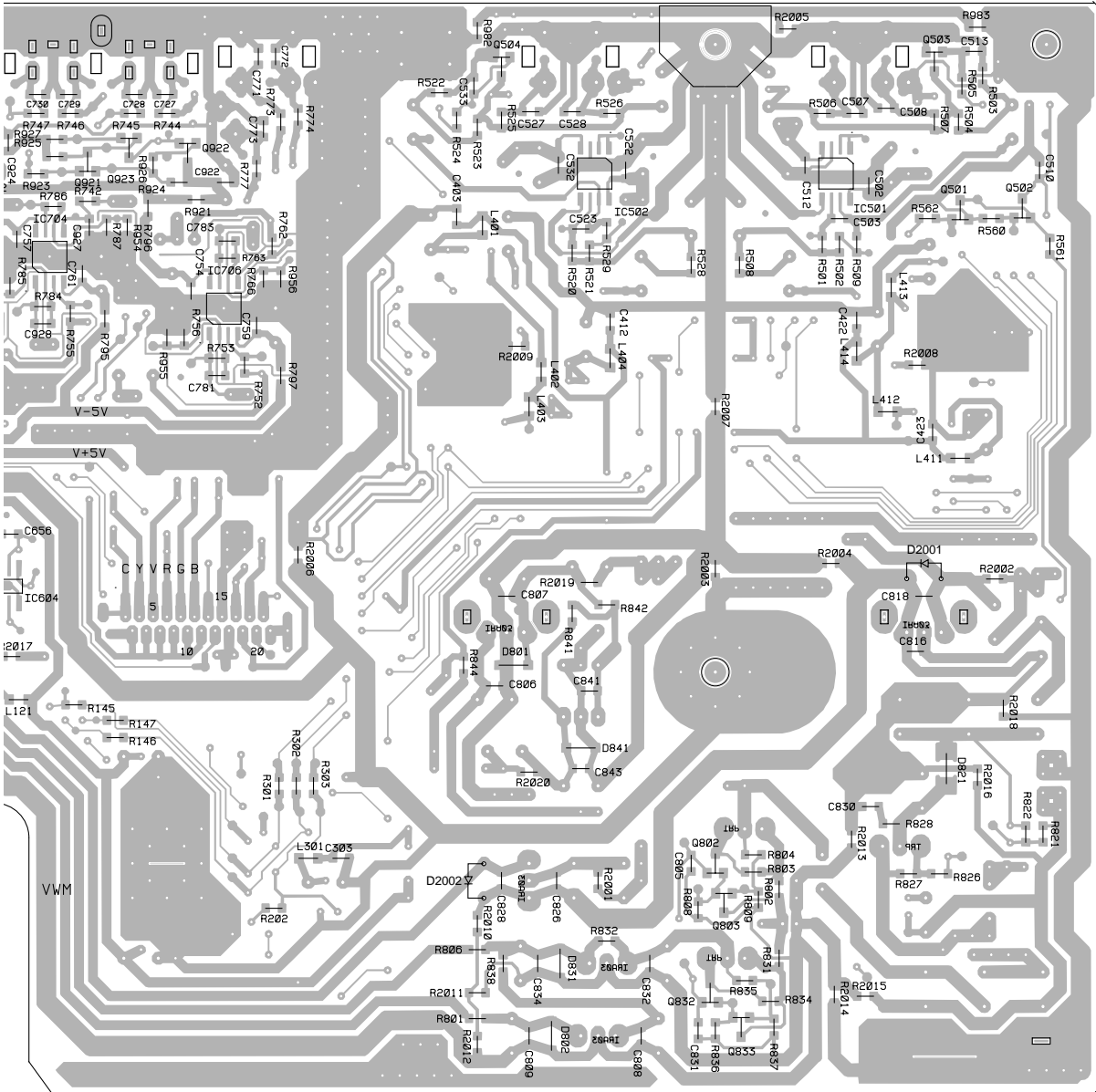

(VNP1658-A)





4.6 SCRB ASSY

**K** SCRB ASSY

**I** CN103

**SIDE A**

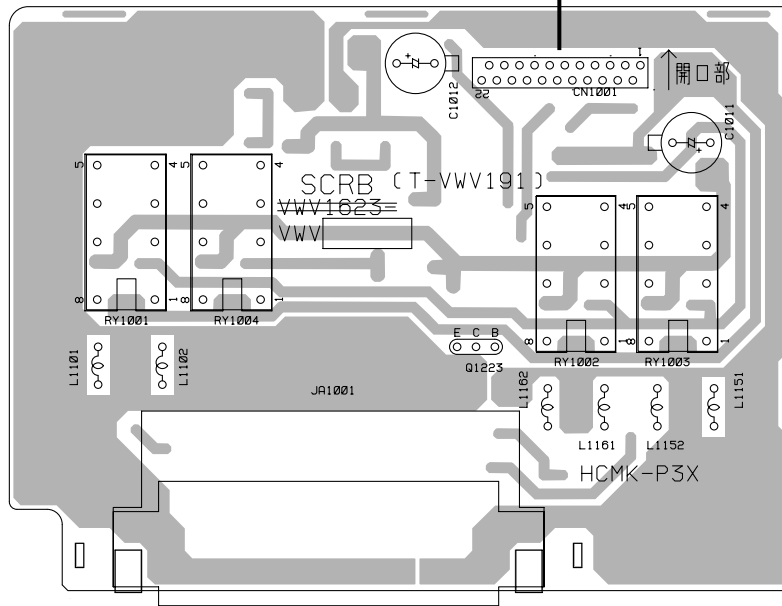

(VNP1658-A)

Q1225

**K** SCRB ASSY

**SIDE B**

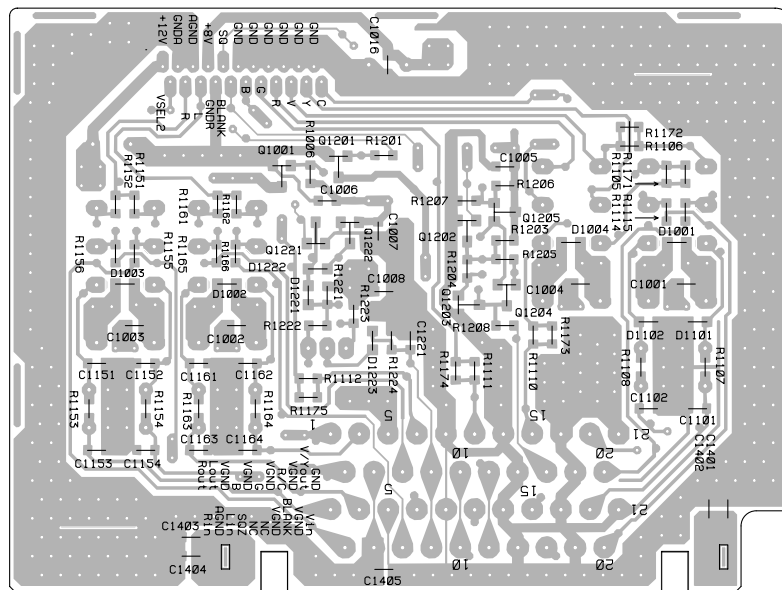

(VNP1658-A)

Q1001 Q1201 Q1202 Q1205  
Q1222 Q1203 Q1204

### 4.7 POWER SUPPLY and MSWB ASSEMBLIES

**SIDE A**

## **M** POWER SUPPLY ASSY

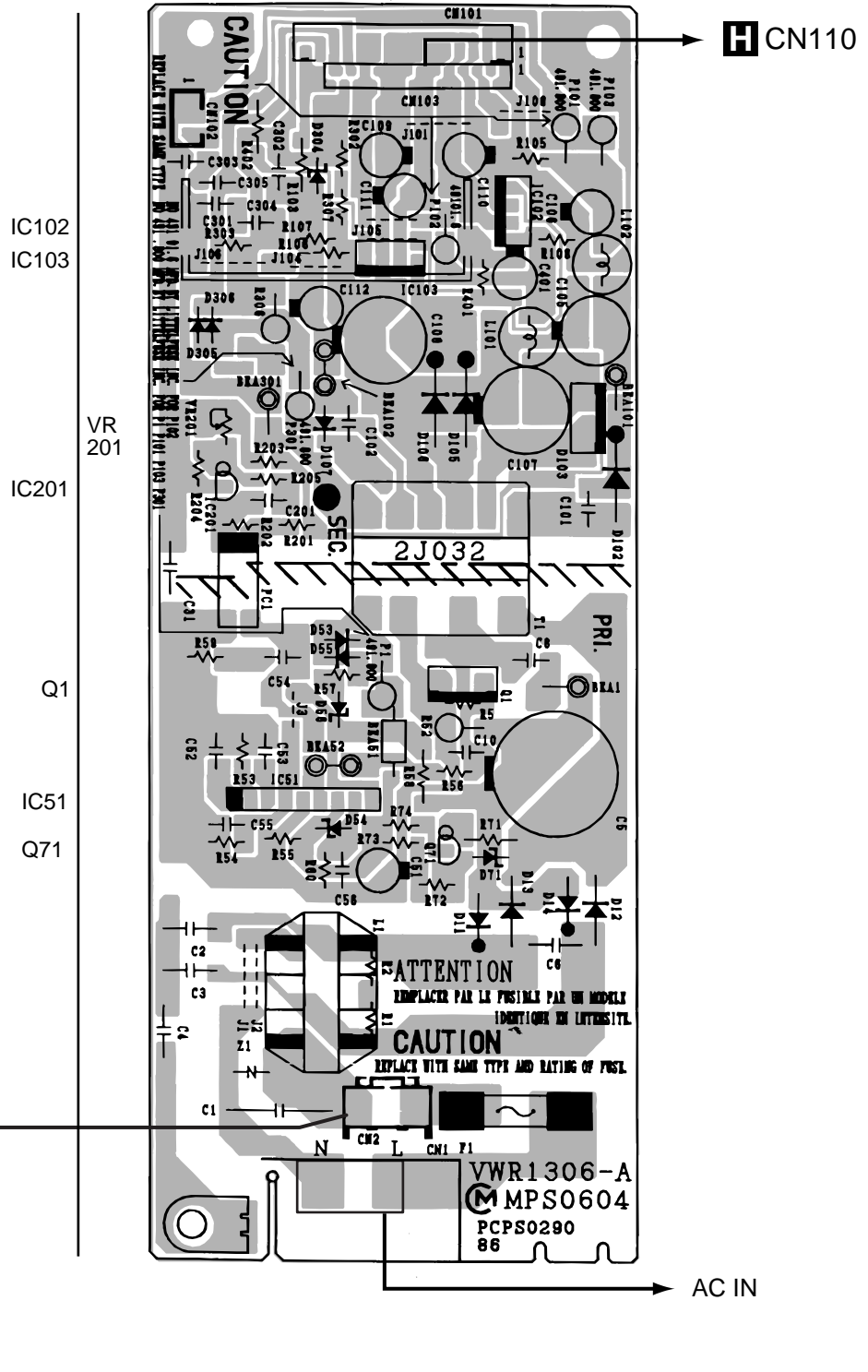

## **L** MSWB ASSY

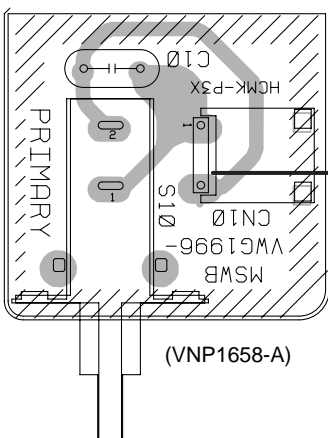

# 5. PCB PARTS LIST

NOTES: ● Parts marked by "NSP" are generally unavailable because they are not in our Master Spare Parts List.

● The  $\Delta$  mark found on some component parts indicates the importance of the safety factor of the part. Therefore, when replacing, be sure to use parts of identical designation.

● When ordering resistors, first convert resistance values into code form as shown in the following examples.

Ex.1 When there are 2 effective digits (any digit apart from 0), such as 560 ohm and 47k ohm (tolerance is shown by J=5%, and K=10%).

560 → 56 x 10<sup>1</sup> → 561 ..... RD1/4PU 561J  
 47k → 47 x 10<sup>3</sup> → 473 ..... RD1/4PU 473J  
 0.5 → R50 ..... RN2H R50K  
 1 → 1R0 ..... RS1P 1R0K

Ex.2 When there are 3 effective digits (such as in high precision metal film resistors).

5.62k → 562 x 10<sup>1</sup> → 5621 ..... RN1/4PC 5621F

Mark	No.	Description	Part No.	Mark	No.	Description	Part No.
------	-----	-------------	----------	------	-----	-------------	----------

## ■ LIST OF WHOLE PCB ASSEMBLIES

NSP	LOAB ASSY	VWM1798
NSP	└ LOMB ASSY	VWG1886
NSP	└ LOSB ASSY	VWG1885
NSP	SMEB ASSY	VWG1968
NSP	FGSB ASSY	VWG2009
NSP	FLKB ASSY	VWM1860
NSP	└ FLKY ASSY	VWG1980
NSP	└ PWSB ASSY	VWG1988
NSP	└ DILB ASSY	VWG1991
	DVDM ASSY	VWS1349
NSP	JKSB ASSY	VWM1863
	└ AVJB ASSY	VWV1617
	└ SCRB ASSY	VWV1623
NSP	└ MSWB ASSY	VWG1996
	DNRB ASSY	VWV1619
$\Delta$	POWER SUPPLY ASSY	VWR1306

## **A** LOMB ASSY

### OTHERS

CN401	KR CONNECTOR	B2B-PH-K-S
-------	--------------	------------

## **B** LOSB ASSY

### SWITCH

S301		VSK1011
------	--	---------

### OTHERS

CN303	KR CONNECTOR	B2B-PH-K-S
CN302	8P FFC CONNECTOR	VKN1268
CN301	12P FFC CONNECTOR	VKN1272

## **C** SMEB ASSY

### SWITCH

S201		DSG1016
------	--	---------

## OTHERS

CN201	3P FFC CONNECTOR	52044-0345
CN202	8P FFC CONNECTOR	VKN1212
	PC BOARD(SMEB)	VNP1654

## **D** FGSB ASSY

### SEMICONDUCTOR

PC101		TLP910(O)
-------	--	-----------

### RESISTORS

All Resistors		RS1/10S□□□J
---------------	--	-------------

## ■ FLKB ASSY

### OTHERS

PC BOARD(FLKB)		VNP1656
----------------	--	---------

## **E** FLKY ASSY

### SEMICONDUCTORS

IC101		PE5018B
IC102		S-806D
Q101		DTD113ES
Q102		PDTA124EK
D102		EP05Q04

### SWITCHES AND RELAYS

S101-S105		RSG1030
-----------	--	---------

### CAPACITORS

C101, C103, C117		CEJA470M6R3
C108, C110-C113		CKSQYB102K50
C106, C107, C114-C116, C119		CKSQYF104Z25
C123, C170		CKSQYF104Z25

### RESISTORS

All Resistors		RS1/10S□□□J
---------------	--	-------------

Mark	No.	Description	Part No.
<b>OTHERS</b>			
	CN102	CONNECTOR 7P REMOTE RECEIVER UNIT	07P-FJ GP1U28X
	J101	CONNECTOR ASSY	PF02NN2D12
	V101	FL TUBE SPACER	VAW1046 VEC1599
	CN101	14P CONNECTOR HOLDER	VKN1274 VNF1087
	X101	CERAMIC RESONATOR (5MHz)	VSS1104

**F PWSB ASSY**

**SEMICONDUCTORS**

Q201	PDTC124EK
D201-D204	SLP9118C51H

**CAPACITORS**

C201	CKSQYF104Z25
------	--------------

**RESISTORS**

All Resistors	RS1/10S□□□J
---------------	-------------

**OTHERS**

CN201	CONNECTOR 7P	07R-FJ
-------	--------------	--------

**G DILB ASSY**

**SEMICONDUCTORS**

D301	MA111
------	-------

**OTHERS**

PL301	LAMP	VEL1022
-------	------	---------

**H DVDM ASSY**

**SEMICONDUCTORS**

IC301	ADC1175CIJMX
IC371	BA10393F
△ IC401	BA178M08FP
IC352	BA5982FP
IC251	BA6195FP
IC901	CY2081SL-638
IC702	HM514800CJ-7
IC101	LA9701M
IC201	LC78651W
IC802	MB811171622A-100FN
IC801	MB86371C
IC261, IC302	NJM2100M
IC601	PD3381A
IC701	PD4833A
IC602	PDK036A
IC501	PE5012A
IC502	SRM2B256SLMX70
IC604	TC551001BFL-85

Mark	No.	Description	Part No.
	IC504		TC74HC573AF
	IC303		TC74HCU04AF
	IC807, IC808		TC74LCX245FT
	IC810		TC74VHC00FT
	IC506, IC605		TC74VHC139FT
	IC505		TC74VHC20FT
	IC805, IC806, IC809		TC74VHC541FT
	IC507		TC74VHCT245AFT
	IC703		TC74VHCT541AFT
	IC903, IC904, IC906		TC7WU04F
	IC603		VYW1599
△	Q401		2SB1260

Q603	DTA114EK
Q107, Q602	DTC114EK
Q601, Q661, Q662, Q803	DTC114TK
Q108	HN1K03FU
Q102, Q106, Q109	IMT1A

Q101, Q105, Q112-Q114, Q201	IMX1
Q402	IMX1
Q103, Q281, Q301	IMZ1A
D301	KV1410
D371, D372	MA152WK

D601	RB501V-40
------	-----------

**COILS AND FILTERS**

F6630, F6640, F6710	CHIP BEADS	DTF1067
F4010, F4020, F4030	CHIP BEADS	DTF1070
F4040, F4050, F4060	CHIP BEADS	DTF1070
F8010, F8050, F8900	CHIP BEADS	DTF1070
F8920, F8990	CHIP BEADS	DTF1070

F8450, F8460	FERRITE BEADS	VTF1073
L304	(1.5mH)	VTL1059
L101, L303	(10mH)	VTL1061
L804	(22μH)	VTL1067
L6740, L6750, L6760	CHIP BEADS	VTL1075

L6770, L6780, L6790	CHIP BEADS	VTL1075
L6800, L6810, L6820	CHIP BEADS	VTL1075
L9050, L9580, L9590	CHIP BEADS	VTL1075
L9620, L9630, L9870	CHIP BEADS	VTL1075
L9880, L9890, L9960	CHIP BEADS	VTL1075

L8420	CHIP BEADS	VTL1108
-------	------------	---------

**CAPACITORS**

C605	CCSRCH100D50
C123, C282, C610, C611, C716	CCSRCH101J50
C903	CCSRCH101J50
C206, C210, C211, C240	CCSRCH151J50
C126, C307, C905	CCSRCH180J50

C116	CCSRCH220J50
C152, C208	CCSRCH221J50
C135	CCSRCH270J50
C322	CCSRCH330J50
C352, C360	CCSRCH331J50

C104-C108, C124, C209, C314	CCSRCH470J50
-----------------------------	--------------









Mark	No.	Description	Part No.
	CN102, CN103	22P CONNECTOR	VKN1253
	CN101	26P CONNECTOR SCREW PLATE	VKN1257 VNE1948
	KN1-KN3	EARTH METAL FITTING	VNF1084
	X201	CERAMIC RESONATOR(24MHz)	VSS1118

## J DNRB ASSY

### SEMICONDUCTORS

△	IC301	BA178M05FP
	IC101	CXD1854Q
	IC102	MC44724A
	IC103	TC74HCT02AF
	IC104	TC74HCT74AF
	IC105	TC7WU04F
	Q501, Q502, Q511, Q512	2PB709A
	Q521, Q522, Q541, Q542	2PB709A
	Q551, Q552, Q622	2PB709A
	Q621	2PD601A

### COILS AND FILTERS

F1102, F201, F202, F501	DTF1070
F101, F102	VTF1147
L9404, L9409	VTL1074
L621	VTL1113

### CAPACITORS

C402	CCSRCH101J50
C622	CCSRCH470J50
C106, C213, C302, C304, C307	CEV470M6R3
C301, C303, C305, C306, C404	CKSQYF104Z25
C102	CKSQYF105Z16
C101, C103-C105, C107, C201	CKSRYF104Z16
C203, C205, C207, C209, C212	CKSRYF104Z16
C214, C215, C217-C220, C401	CKSRYF104Z16
C403, C501, C502, C511, C512	CKSRYF104Z16
C521, C522, C541, C542	CKSRYF104Z16
C551, C552, C623	CKSRYF104Z16

### RESISTORS

R133, R134, R311, R312	RA4C470J
R313, R314, R322, R9101	RS1/10S0R0J
R9401, R9402	RS1/10S0R0J
R217, R219	RS1/16S1001F
R214, R215	RS1/16S1801F
R216, R218	RS1/16S2201F
R505, R515, R525, R545, R555	RS1/16S5600F
VR501-VR503, VR505, VR506(220Ω)	VCP1179
Other Resistors	RS1/16S□□□□J

### OTHERS

CN101	CONNECTOR	VKN1530
-------	-----------	---------

Mark	No.	Description	Part No.
------	-----	-------------	----------

## K SCRB ASSY

### SEMICONDUCTORS

Q1204	2PB709A
Q1001, Q1201, Q1203, Q1205	2PD601A
Q1223	2SA933S
Q1202, Q1221, Q1222	PDTC124EK
D1002, D1004, D1223	MA111
D1221, D1222	UDZS5.1B

### SWITCHES AND RELAYS

RY1001-RY1004	RSR1029
---------------	---------

### CAPACITORS

C1151, C1152, C1161, C1162	CCSQCH391J50
C1012	CEAT101M10
C1011	CEAT101M16
C1001-C1008, C1016, C1221	CKSQYF104Z25
C1401-C1405	CKSQYF104Z25

### RESISTORS

R1105, R1106, R1110-R1112, R1208	RN1/10SC75R0D
R1171-R1175	RN1/10SE1801D
R1151, R1152, R1161, R1162	RN1/10SE2200D
Other Resistors	RS1/10S□□□J

### OTHERS

JA1001	CONNECTOR	VKB1056
CN1001	22P CONNECTOR	VKN1282
	EARTH PLATE	VNF1097

## L MSWB ASSY

### SWITCHES AND RELAYS

△ S10	ASG1006
-------	---------

### CAPACITORS

△ C10	ACG7010
-------	---------

### OTHERS

△ CN10	CONNECTOR2P	2-178496-4
--------	-------------	------------

## M POWER SUPPLY ASSY

### OTHERS

△ F1	FUSE (2.5A)	REK1102
△ P101	PROTECTOR (1A)	AEK7009
△ P103, P301	PROTECTOR (800mA)	AEK7008
△ P102	PROTECTOR (1.6A)	AEK7012

## 6. ADJUSTMENT

### 6.1 ADJUSTMENT ITEMS AND LOCATION

#### ■ Adjustment Points (PCB Part)

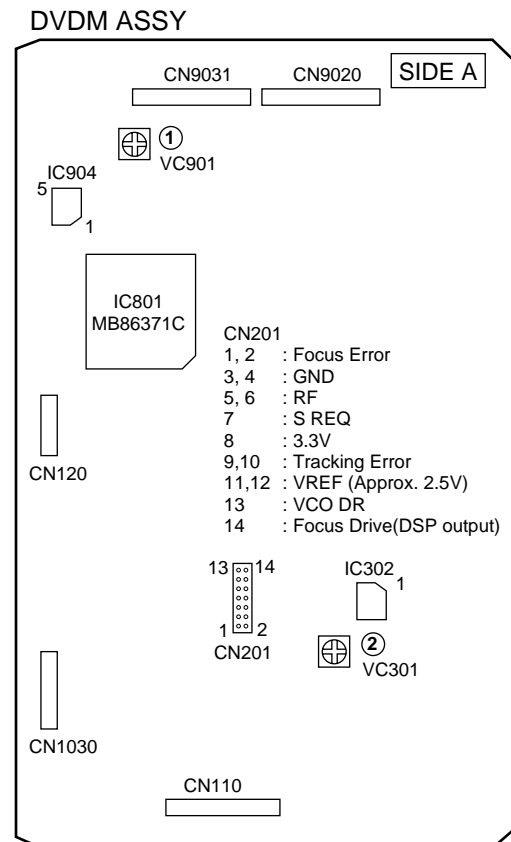

#### ■ Adjustment Items

[Electrical Part]

- ① 16MHz Master Clock Adjustment
- ② VCO Offset Adjustment
- ③ Y Level Adjustment
- ④ C Level Adjustment
- ⑤ R Level Adjustment
- ⑥ G Level Adjustment
- ⑦ B Level Adjustment

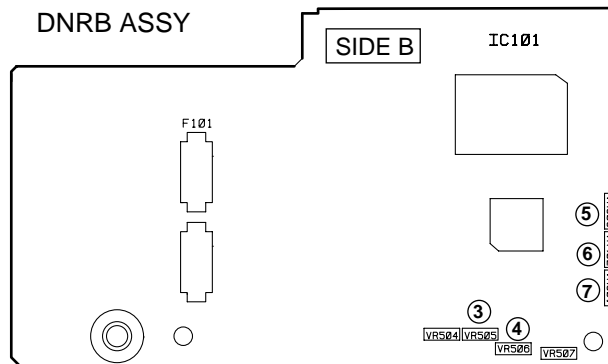

#### ■ How to output the VIDEO SIGNAL without the DNRB ASSY

##### a) When PC Board No. is VNP1651

- ① Connect A1 and A2 with the wire jumper
- ② Connect B1 and B2 with the Resistor(150Ω)

##### b) When PC Board No. is VNP1684



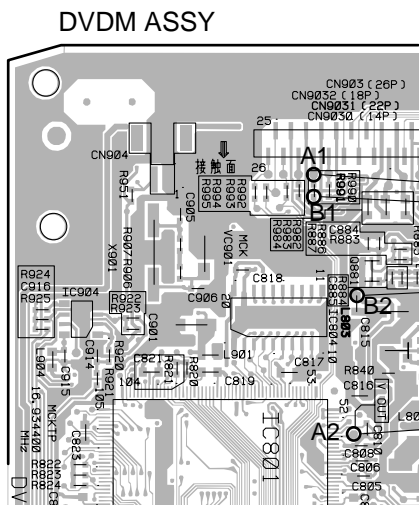

- ① Connect A1 and A2 with the wire jumper

Note: The PC Board was running-changed from VNP1651 to VNP1684

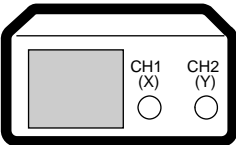

location  
 A1:R991(CN9031 20pin)  
 A2:IC801 45pin  
 B1:R991  
 B2:L803(Resistor 0Ω)

### 6.2 JIGS AND MEASURING INSTRUMENTS

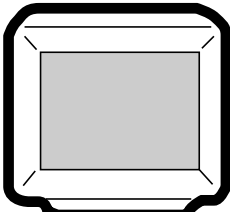
 <p>DVD test disc (DVD-MJK1)</p>	 <p>⊖ Screwdriver(small)</p>	 <p>⊕ Screwdriver(small)</p>	 <p>Dual-trace oscilloscope (with delay) Frequency band <math>\geq</math> 40MHz</p>
 <p>Frequency counter Display digit <math>\geq</math> 8-digit</p>	 <p>TV monitor</p>		

### 6.3 NECESSARY ADJUSTMENT POINTS

When	Adjustment Points
<p>■ EXCHANGE PCB ASSY</p>	
<p>Exchange board AVJB ASSY</p>	<p>Mechanical point _____</p> <p>Electric point _____</p>
<p>Exchange board DVDM ASSY</p>	<p>Mechanical point _____</p> <p>Electric point _____</p> <p>Note : ① and ② are adjusted already.</p>
<p>Exchange board DNRB ASSY</p>	<p>Mechanical point _____</p> <p>Electric point _____</p> <p>Note : ③ , ④ , ⑤ , ⑥ and ⑦ are adjusted already.</p>

## 6.4 ELECTRICAL ADJUSTMENT

### ① 16MHz Master Clock Adjustment

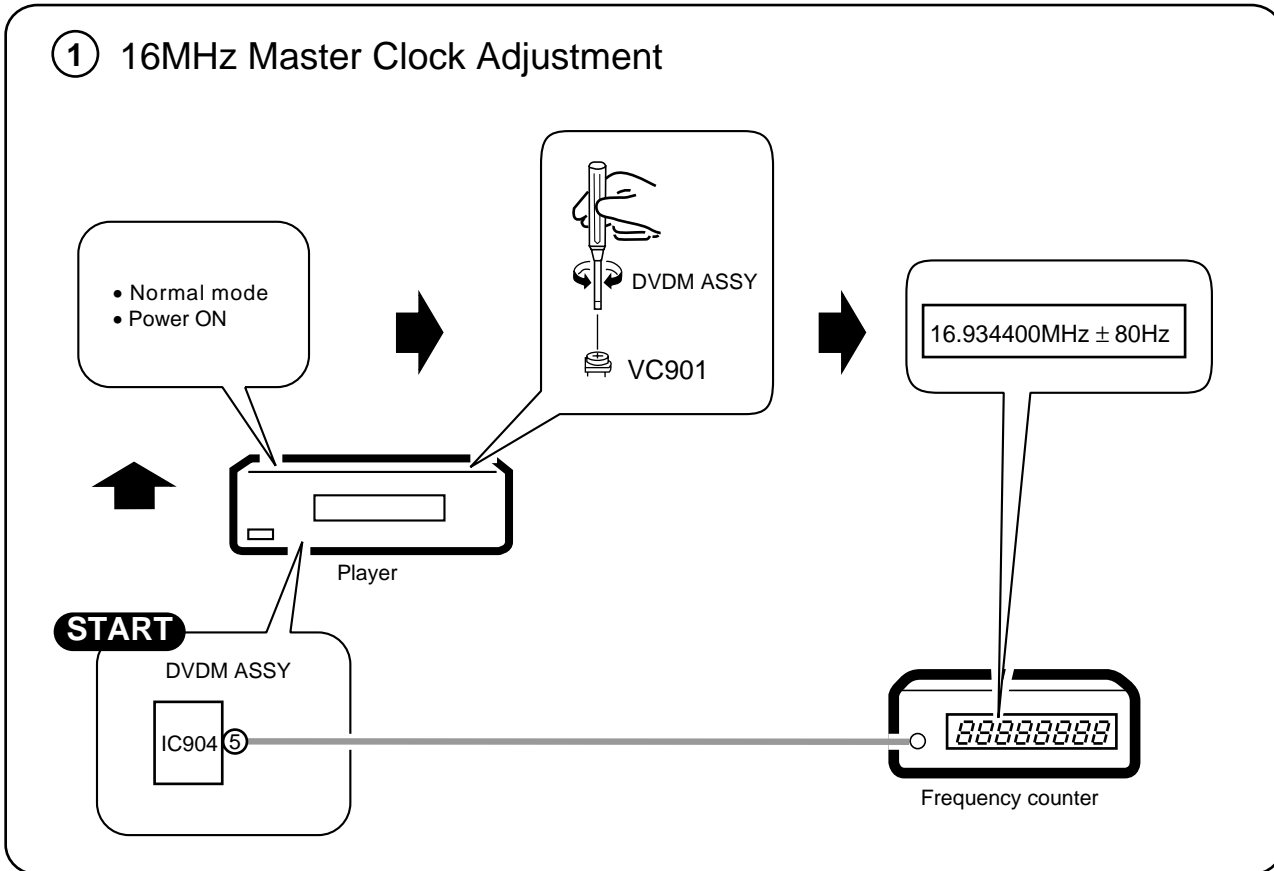

### ② VCO Offset Adjustment

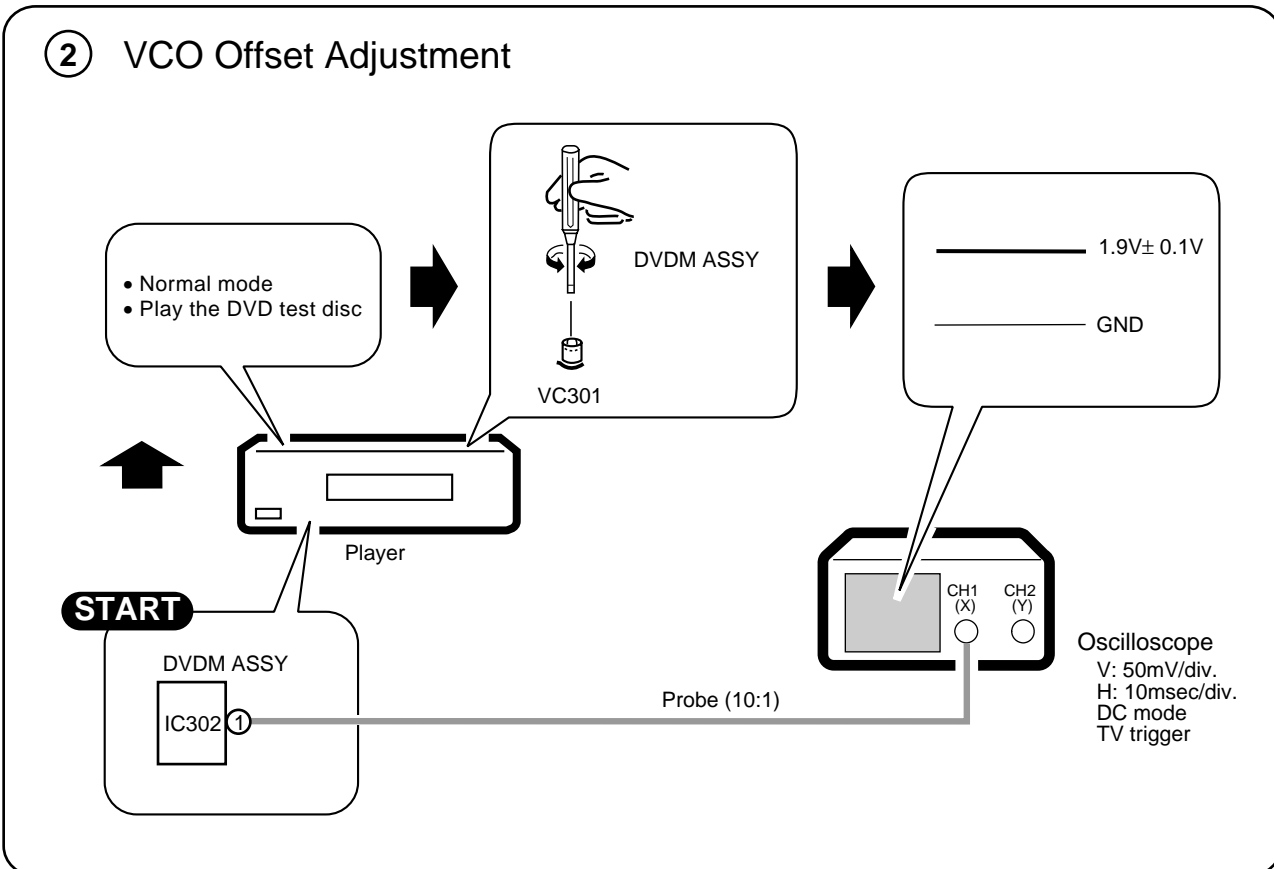

### ③ Y Level Adjustment

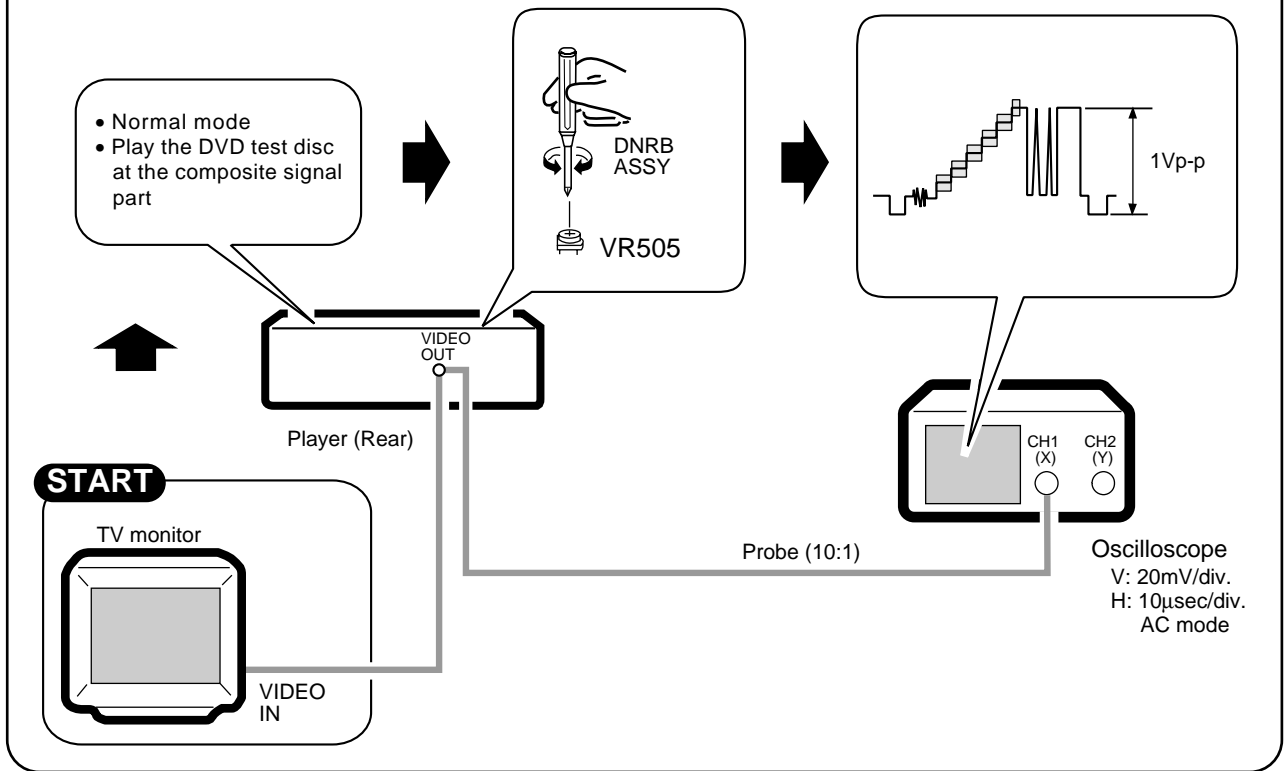

### ④ C Level Adjustment

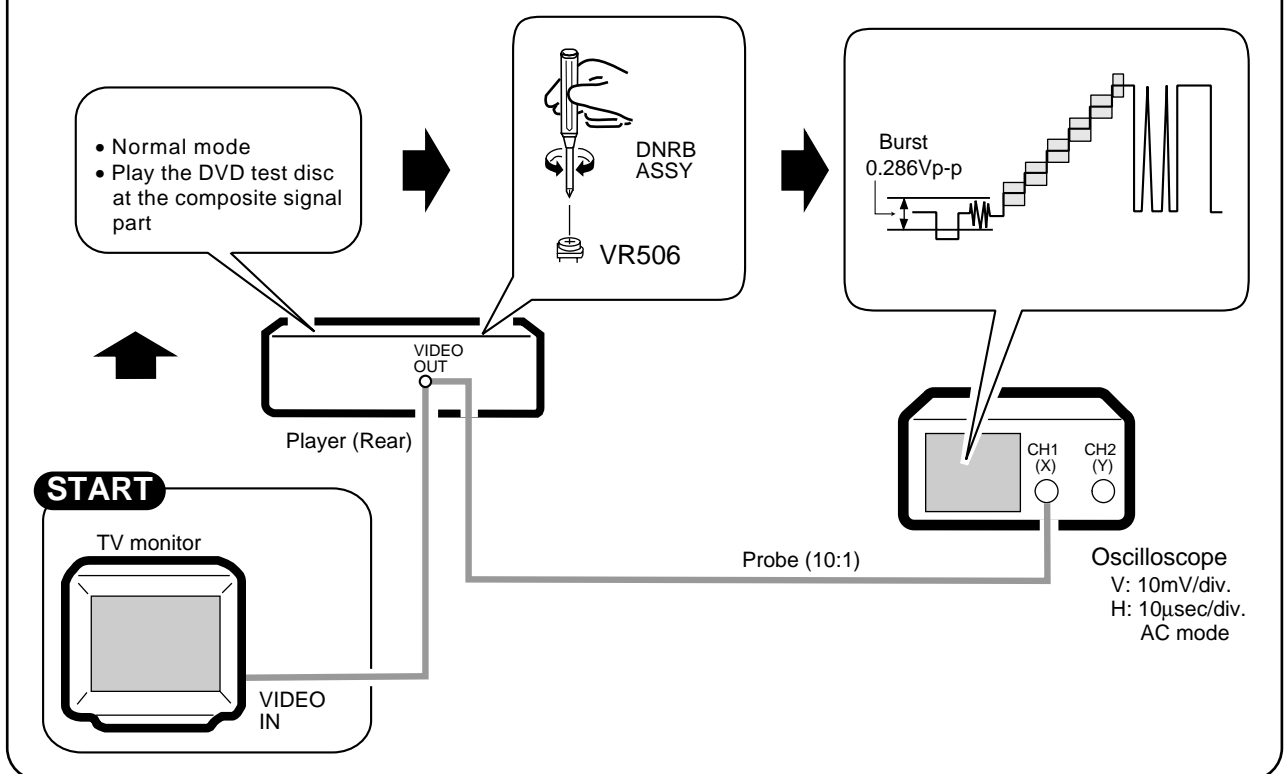

### ⑤ R Level Adjustment

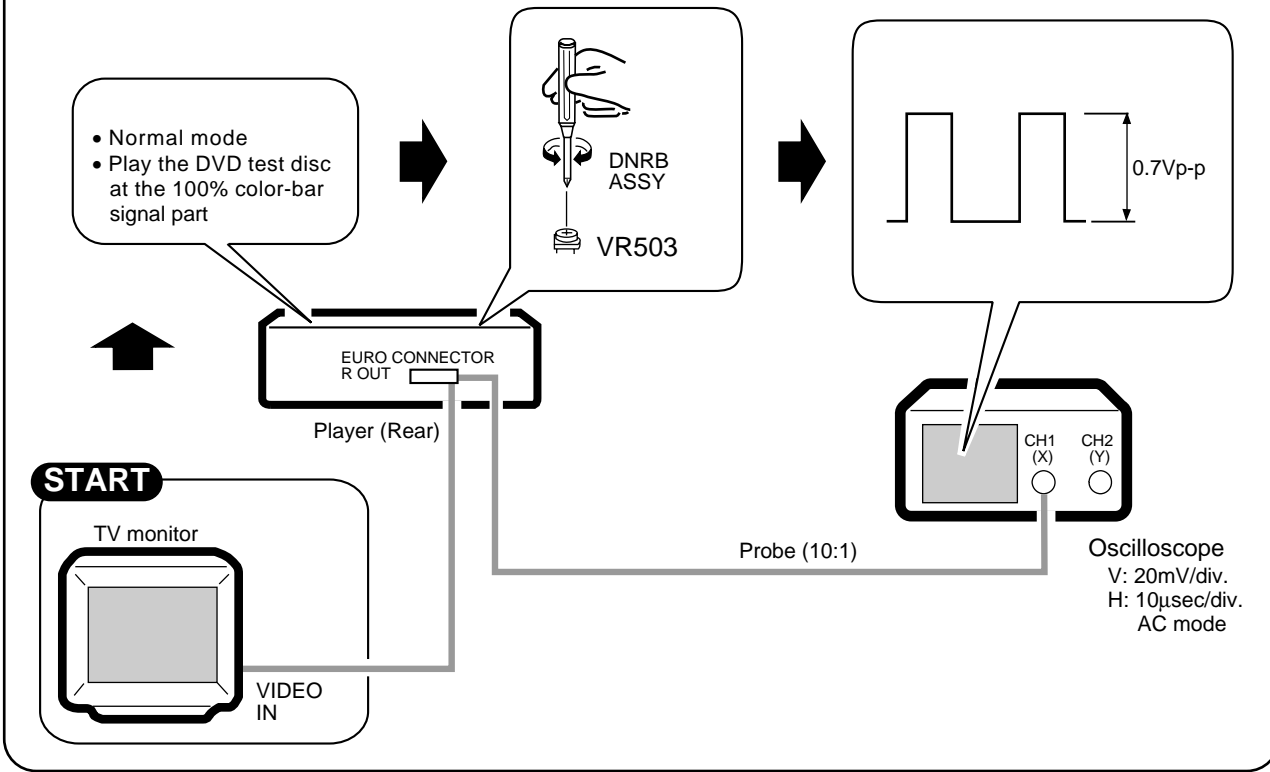

### ⑥ G Level Adjustment

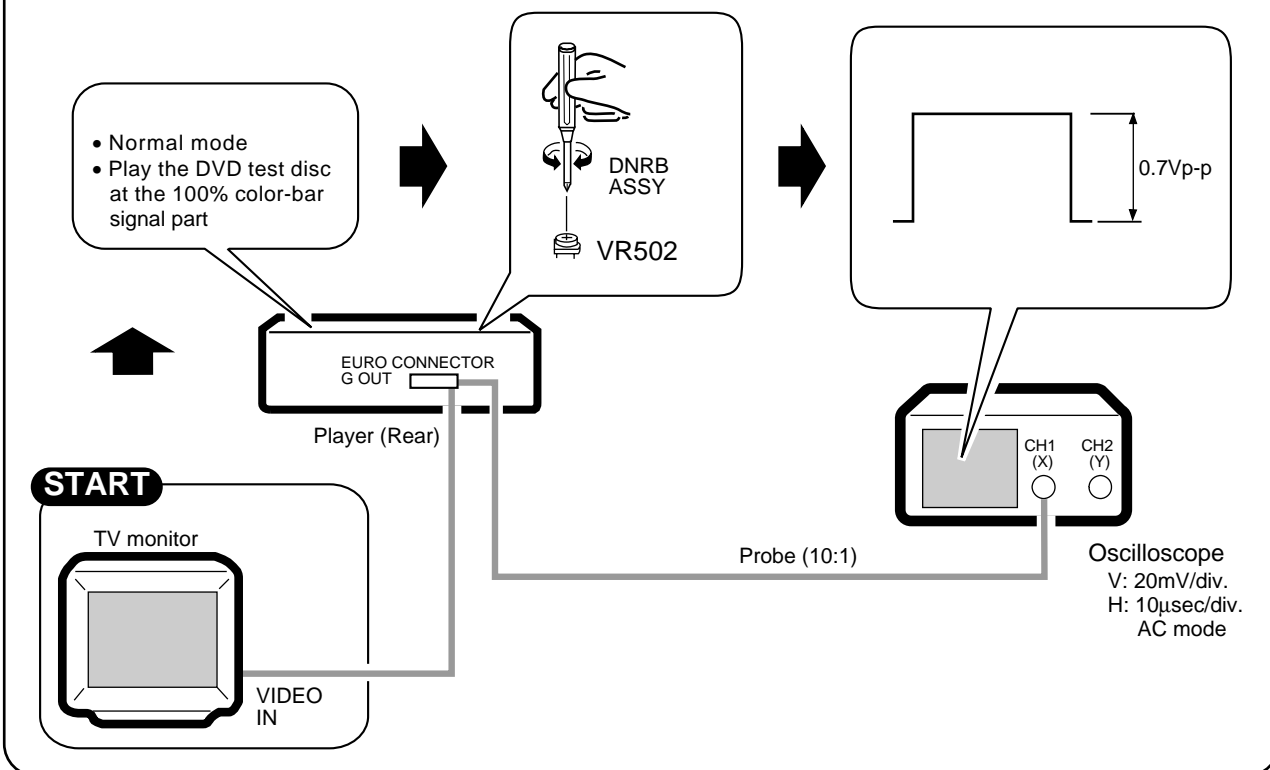

## ⑦ B Level Adjustment

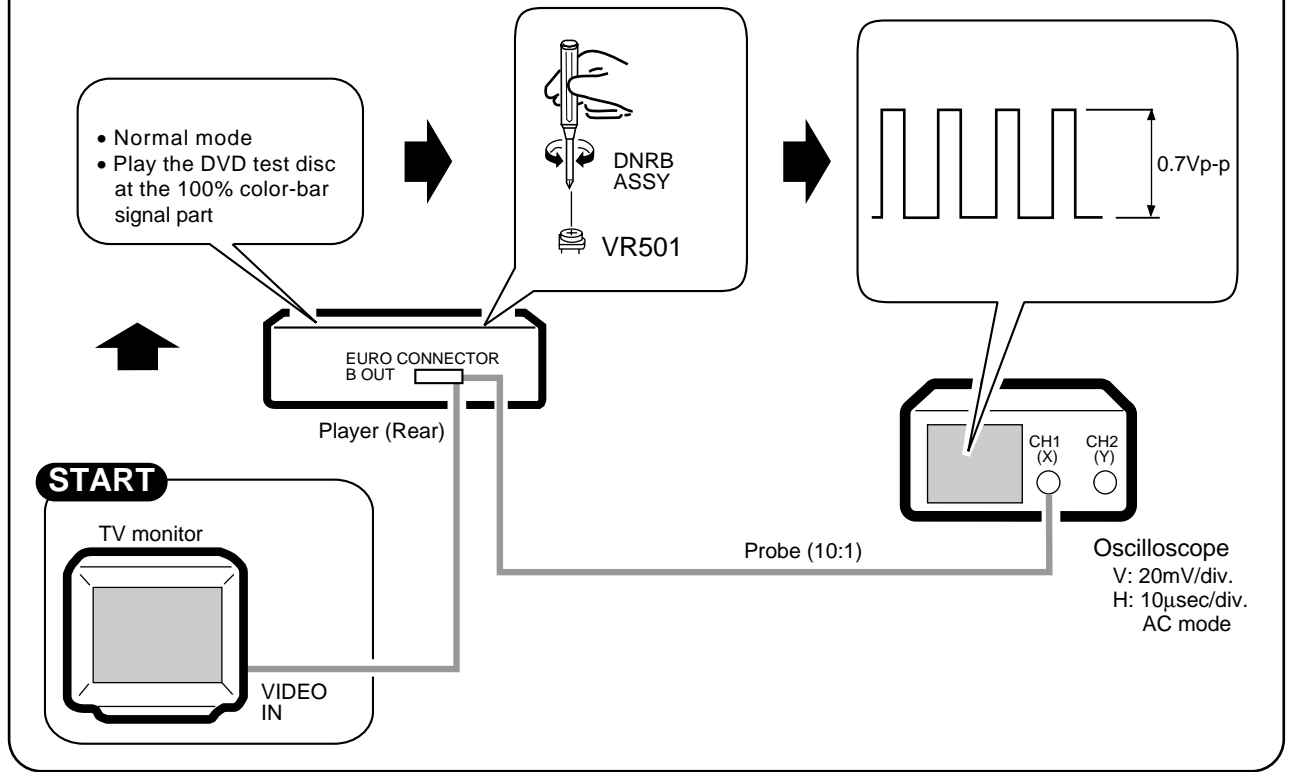

## 7. GENERAL INFORMATION

### 7.1 PARTS

#### 7.1.1 IC

• The information shown in the list is basic information and may not correspond exactly to that shown in the schematic diagrams.

#### •List of IC

PE5018B, PE5012A, PD3381A

#### ■PE5018B (FLKY ASSY : IC101)

##### • FL Control IC

#### • Pin Function

No.	Mark	Pin Name	I/O	Function	No.	Mark	Pin Name	I/O	Function
1	P94	G7	O	FL timing output H: ON	41	P32	P32	I	Not used
2	P93	G6			42	P31	P31	I	Not used
3	P92	G5			43	P30	(NC)	O	Non connection
4	P91	G4			44	P03	P03	I	Not used
5	P90	G3			45	P02	ON POWER	I	Switch the STBY/POWER ON at FL controller is rised u.p L: STBY
6	P81	G2			46	P01	LT	I	Communication handshake line with system controller H: Communication permission
7	P80	G1			47	P00	SEL IR	I	Remote control signal input
8	VDD	VCC	-	Power supply pin	48	IC	IC	-	-
9	P27	(NC)	O	Non connection	49	P72	(NC)	O	Non connection
10	P26	(NC)	O	Non connection	50	P71	FL OFF LED	O	FL OFF LED ON/OFF L: ON
11	P25	(NC)	O	Non connection	51	P70	V.D.S. LED	O	Virtual Dolby Surround LED ON/OFF L:ON (DV-515 only)
12	P24	LAMP	O	DVD lamp ON/OFF H: ON	52	VDD	VDD	-	Power supply pin
13	P23	XREADY	O	Communication handshake line with system controller L: Communication permission	53	P127	(NC)	O	Non connection
14	P22	SCK	I/O	Communication clock output with system controller	54	P126	(NC)		
15	P21	SO	I/O	Communication data output with system controller	55	P125	(NC)		
16	P20	SI	I	Communication data input with system controller	56	P124	(NC)		
17	RESET	RESET IN	I	Reset input L: Reset	57	P123	(NC)		
18	P74	(NC)	O	Non connection	58	P122	(NC)		
19	P73	(NC)	O	Non connection	59	P121	(NC)		
20	AVSS	VSS	-	GND	60	P120	(NC)		
21	P17	POWER ON	O	SW 5V ON/OFF H: ON	61	P117	P15		
22	P16	RESET OUT	O	System reset input L: Reset	62	P116	P14		
23	P15	(NC)	O	Non connection	63	P115	P13		
24	P14	KIN2	I	Key input	64	P114	P12		
25	P13	KIN1			65	P113	P11		
26	P12	KIN0			66	P112	P10		
27	P11	MS1	I	Destination discrimination input	67	P111	P9		
28	P10	MS0			68	P110	P8		
29	AVDD	AVDD	-	Power supply pin	69	P107	P7		
30	AVREF	AVREF	-	Reference power supply pin	70	P106	P6		
31	P04	P04	I	Not used	71	VLOAD	- 27V	-	Input for - 27V
32	XT2	(NC)	-	Non connection	72	P105	P5	O	FL segment output H: ON
33	VSS	VSS	-	GND	73	P104	P4		
34	X1	X1	I	Connect a microprocessor clock	74	P103	P3		
35	X2	X2	-		75	P102	P2		
36	P37	(NC)	O	Non connection	76	P101	P1		
37	P36	(NC)	O	Non connection	77	P100	G11		
38	P35	(NC)	O	Non connection	78	P97	G10		
39	P34	P34	I	Not used	79	P96	G9		
40	P33	P33	I	Not used	80	P95	G8		



## ■ PE5012A (DVDM ASSY : IC501)

### • Mechanism Control IC

#### • Pin Function

No.	Pin Name	I/O	Function	No.	Pin Name	I/O	Function
1	LODDRV	I/O	Loading motor drive output	33	XCSB	O	DSP parallel command setting output "L"
2	XDF INH	I/O	High impedance (input) at DEFECT ON "L" output at DEFECT OFF	34	ASTB	O	Address strobe of multiplexed address/data bus
3	FOFST3	O	Not used (H fixed)	35	XRESET	I	System reset input "L"
4	EFLG	I	Count data input of error rate Measureable by using timer 1 and 2.	36	SBSY	INT	Subcode frame sync. input (H: S0+S1 period)
5	FSX	I		37	THLD	INT	T HOLD
6	ATBO	I/O	Tracking offset adjustment	38	XABUSY	INT	DSP auto sequence busy input "L"
7	V PB	I	EFM servo lock signal H/L = rough servo / phase servo	39	XMIRQ2	INT	LSI-11 interrupt input "L"
8	FOFST1	I/O	Focus offset adjustment 1	40	VDD	-	Power supply pin
9	VSS	-	GND	41	X2	-	Connect a crystal for main system clock oscillation
10	MAD0	I/O	External address data bus	42	X1	I	Connect a crystal for sub system clock oscillation
11	MAD1			43	VPP	-	Internal connection Connect to Vss.
12	MAD2			44	PXT2	-	Connect a crystal for sub system clock oscillation
13	MAD3			45	XCURDET	I	Acuator over-current detection input "L": Servo OFF for 300 ms.
14	MAD4			46	AVSS	-	Ground for A/D converter
15	MAD5			47	LODPOS	I	Loading clamp position SW input
16	MAD6			48	SLDPOS	I	Slider position SW input
17	MAD7			49	DOORSW	I	Not used
18	MA8	O	External address bus	50	FOFST4	I/O	Not used (H fixed)
19	MA9			51	XDSPRST	O	Not used
20	MA10			52	MON	O	Spindle motor ON output "L"
21	MA11			53	FOFST2	I/O	Focus offset adjustment 2
22	MA12			54	OEICG	O	"H": OEIC gain up to 6dB
23	MA13			55	AVDD	-	Analog power supply for A/D converter
24	VSS	-	GND	56	AVREF	I	Reference voltage input for A/D converter
25	MA14	O	External address bus	57	LD1ON	O	650nm laser diode ON signal
26	MA15			58	LD2ON	O	780nm laser diode ON signal
27	(P60)	O	Not used	59	AGOFF	O	"H": AGC of RFIC turns to OFF
28	DRXLD	O	Not used	60	DVD/XCD	O	H: DVD, L: CD
29	XCBUSY	I	DSP command reception is possible "L"	61	DPDXTE	O	Tracking error switch (H: 1 beam, L: 3 beams)
30	WRQ	I	Readable flag of subcode Q	62	TOFSTA	I/O	Tracking balance adjustment A
31	XMRD	O	CPU read pulse "L"	63	XCD2X	O	Not used
32	XMWR	O	CPU write pulse "L"	64	TOFSTC	I/O	Tracking balance adjustment C

## ■ PD3381A (DVDM ASSY : IC601)

### • System Control IC

### • Pin Function

No.	Pin Name	I/O	Function	No.	Pin Name	I/O	Function
1	PB14/XIRQ6	I	LSI-11 interrupt #1	57	XWRL	O	Low Byte write pulse
2	PB15/XIRQ7	I	AV Chip interrupt #0	58	XWRH	O	High Byte write pulse
3	VSS	-	GND	59	XRD	O	Read pulse
4	AD0	I/O	Data bus	60	PA7	O	Serial data latch pulse
5	AD1			61	VSS	-	GND
6	AD2			62	PA8	I	Final-stage mute of audio output
7	AD3			63	PA9	I	Parallel expansion port enable (S9)
8	AD4			64	PA10/TIOCA1	I	AV Chip interrupt #1
9	AD5			65	PA11/TIOCB1	I	Communication response to FL controller
10	AD6			66	PA12/DACK0	O	
11	AD7	I/O	Data bud	67	PA13/XDREQ0	I	
12	VSS			-	GND	68	PA14/XDACK1
13	AD8	I/O	Data bud	69	PA15/XDREQ1	I	
14	AD9			-	V+5D	70	VCC
15	VCC	-	V+5D	71	CK	O	
16	AD10	I/O	Data bus	72	VSS	-	GND
17	AD11			73	EXTAL	-	20MHz ceramic resonator
18	AD12			74	XTAL	-	
19	AD13			75	VCC	-	V+5D
20	AD14			76	NMI	I	D+5V
21	AD15			77	VCC (Vpp)	-	V+5D
22	VSS	-	GND	78	WDTOVF	O	
23	A0	O	Address bus	79	XRES	I	
24	A1			80	MD0	I	MD1, MD0 = 01 external ROM
25	A2			81	MD1	I	MD1, MD0 = 10 internal ROM
26	A3			82	MD2	I	GND
27	A4			83	VCC	-	V+5D
28	A5			84	VCC	-	V+5D
29	A6			85	AVCC	-	V+5D
30	A7			86	AVref	-	V+5D
31	VSS	-	GND	87	PC0/AN0	I	Rear panel switch H/M/L = NTSC/Auto/PAL
32	A8	O	Address bus	88	PC1/AN1	I	Authoring emulator mode setting
33	A9			89	PC2/AN2	I	(YAKU) special mode setting
34	A10			90	PC3/AN3	I	Reception error (unlock signal) input of DIR (S9)
35	A11			91	AVSS	-	GND
36	A12			92	PC4/AN4	I	Not used
37	A13			93	PC5/AN5	I	Test mode entry
38	A14			94	PC6/AN6	I	CDG data input
39	A15			95	PC7/AN7	I	RS232 transmittable input
40	VSS	-	GND	96	VSS	-	GND
41	A16	O	Address bus	97	PB0/TIOCA2	I	RS232 transmittable output
42	A17	-	V+5D	98	PB1/TIOCB2	I	DAC fs 48/44 selection
43	VCC			99	VCC	-	V+5D
44	A18	O	Address bus	100	PB2/TIOCA3	I	HiBit function ON
45	A19			101	PB3/TIOCB3	I	AV Chip interrupt #2
46	A20			102	PB4/TIOCA4	I	Communication request from FL controller
47	A21			103	PB5/TIOCB4	I	Block sync. input of external digital input (S9)
48	XCS0			O	(N.C. during ROM mode)	104	PB6/TCLKC
49	XCS1	O	External address decoder enable	105	PB7/TCLKD	I	Dolby virtual chip reset & pulse (DV-515 only)
50	XCS2	O		106	VSS	-	GND
51	XCS3	O	LSI-11 chip select	107	PB8/SI0	I	Serial bus data input
52	VSS	-	GND	108	PB9/SO0	O	Serial bus data output
53	PA0/XCS4	O	Dolby virtual chip enable (DV-515 only)	109	PB10/SI1	I	RS-232C RxD
54	PA1/XCS5	O	Dolby virtual chip command/data control (DV-515 only)	110	PB11/SO1	I	RS-232C TxD
55	PA2/XCS6	O	AV Chip chip select	111	PB12/SCK0	I/O	Serial bus clock input and output
56	XWAIT	I	External wait input	112	PB13/XIRQ5	I	LSI-11 interrupt #0

## 7.2 DISASSEMBLY

### BONNET

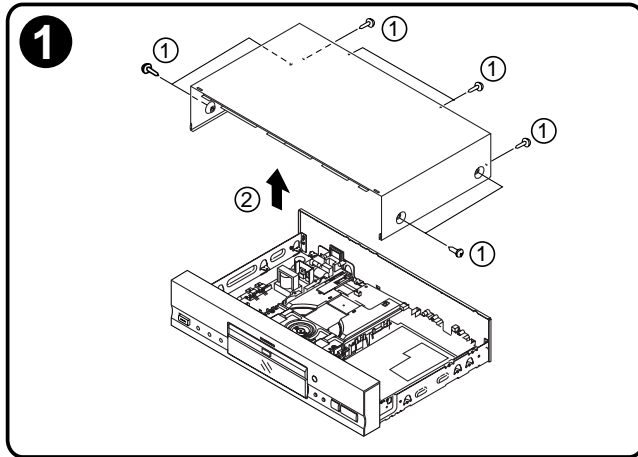

### DISC TRAY

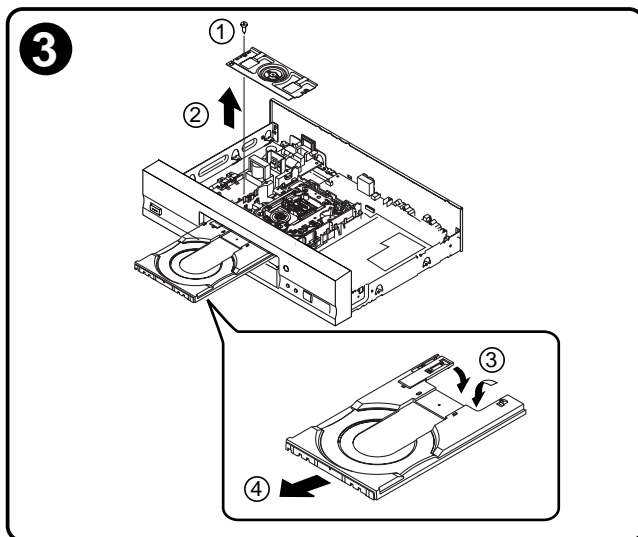
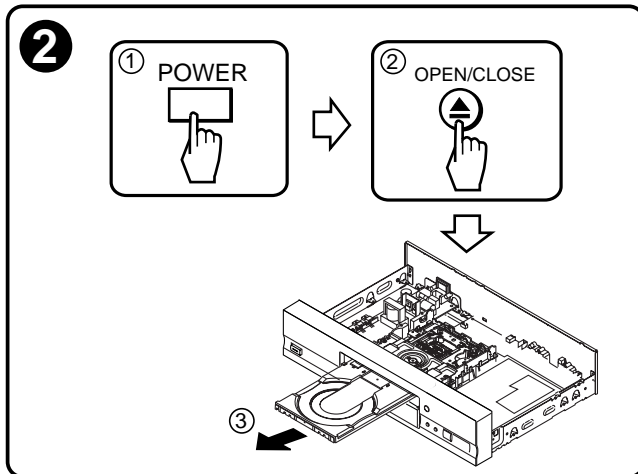

### DVDM ASSY

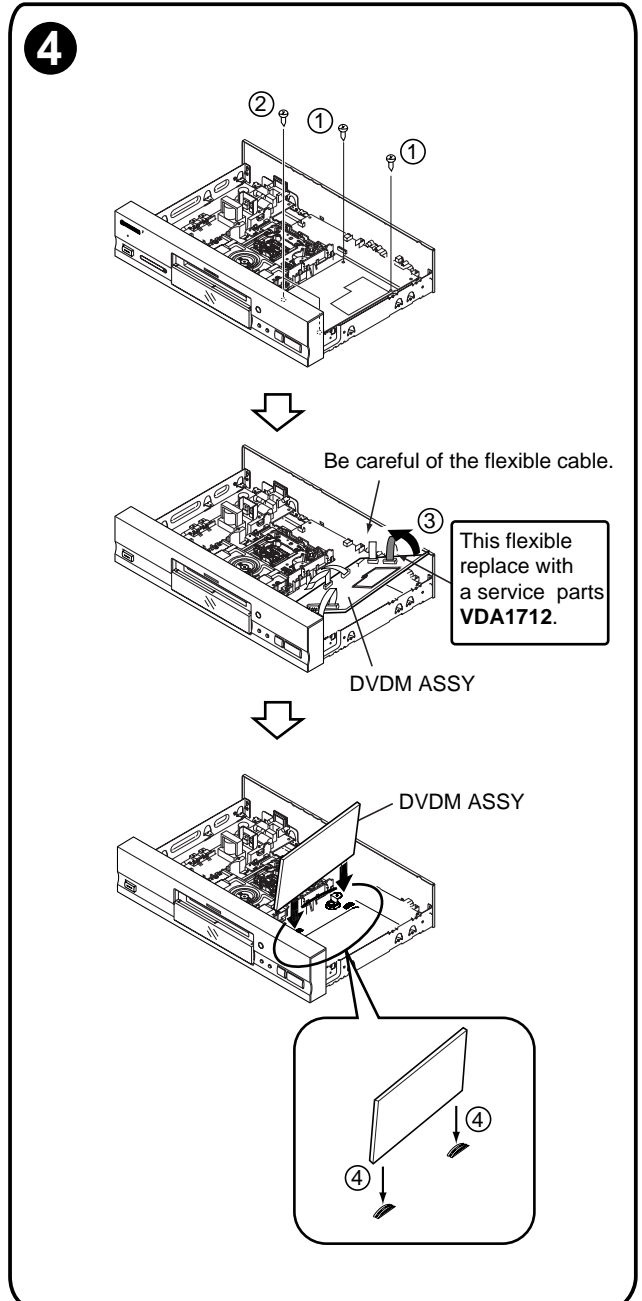

7.3 BLOCK DIAGRAM

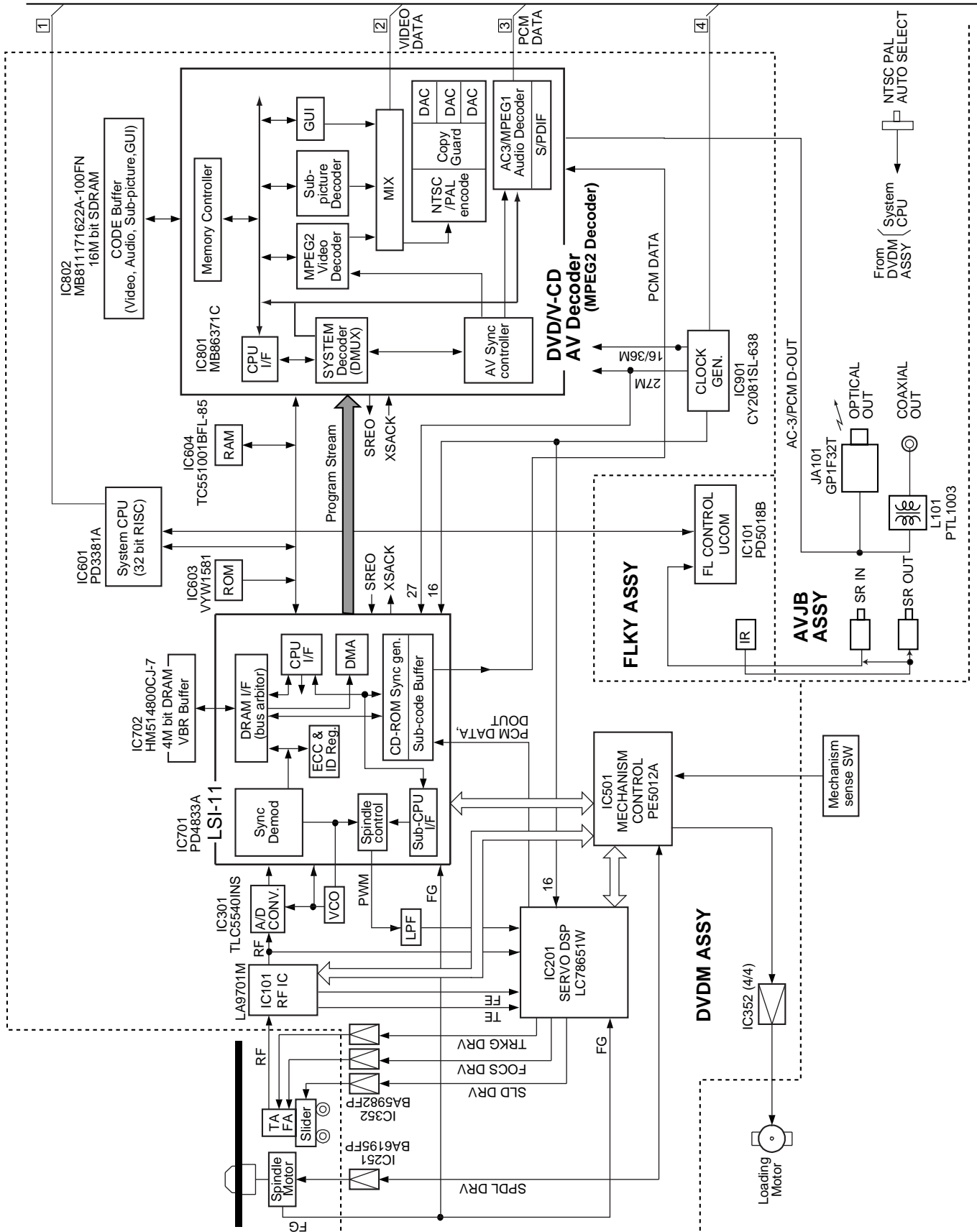

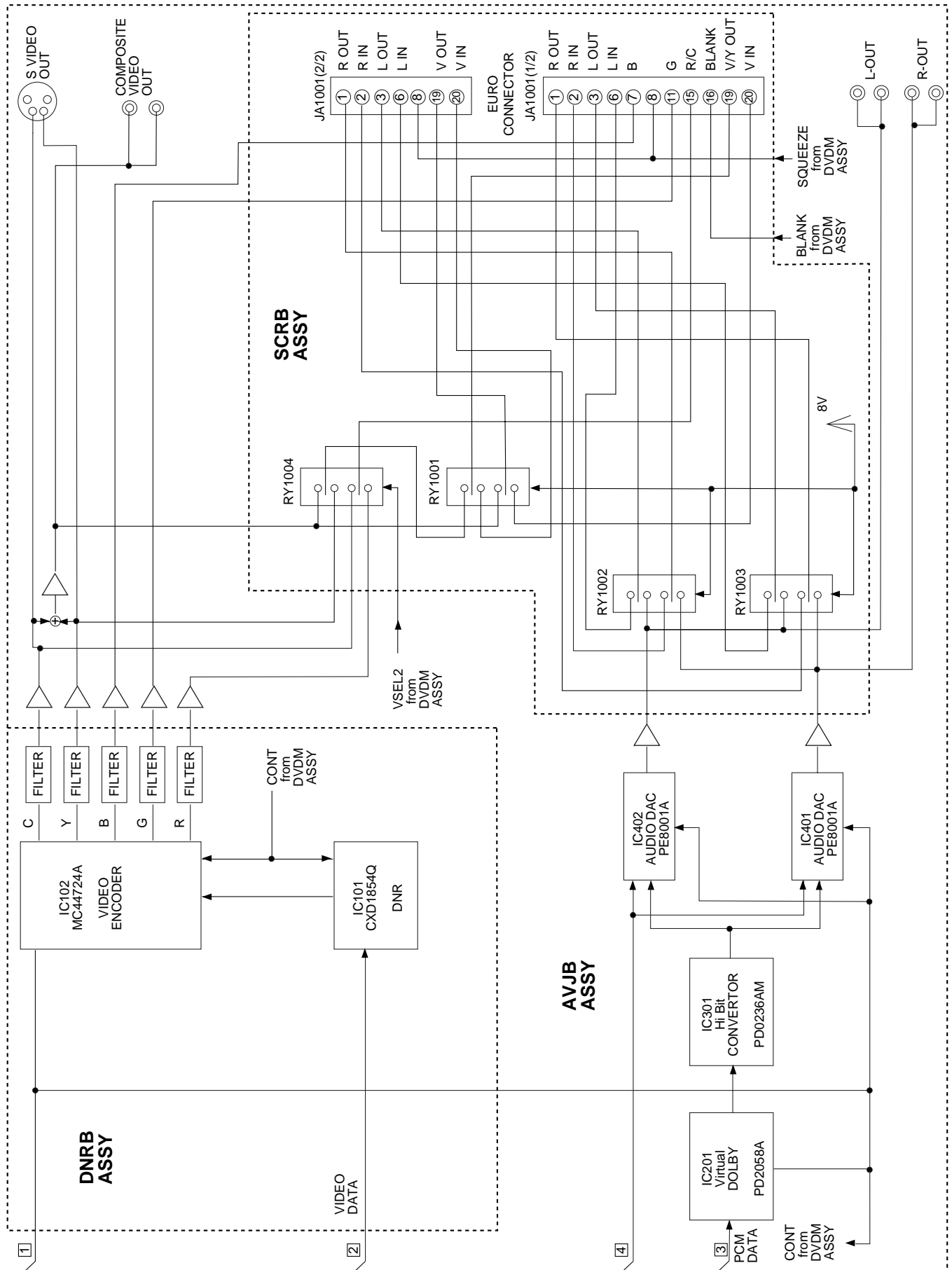

## 7.4 CIRCUIT DESCRIPTION

### 7.4.1 VIDEO SIGNAL PROCESSING BLOCK

#### ■ CXD1854Q Block

The major processing functions of the CXD1854Q block are:

- (1) Field-correlative cyclic digital noise reduction
- (2) Block noise reduction
- (3) Horizontal contour compression

These functions are performed for the Y signal and not performed for the C signal.

#### (1) Field Correlative Cyclic Digital Noise Reduction

For eight-bit digital video data input to the CXD1854Q, noise reduction is achieved through the subtraction of data of one field from the corresponding data one field before. This data is stored in a buffer zone where the subtraction process takes place and this buffer zone is a 512Kbit DRAM.

The noise signal detected as a result is sent to a non-linear circuit. If the difference is larger than a specific value, it is regarded as “a change in picture,” and no canceling calculation is made.

#### (2) Block Noise Reduction

The Horizontal Block Noise components in the field which are generated through DCT for the MPEG encoding are rejected.

They are detected through comparing input data between blocks.

The noise signal detected as a result is sent to a non-linear circuit. If the difference is larger than a specific value, it is regarded as “a change in picture,” and no canceling calculation is made.

#### (3) Horizontal Contour Compensations

This is performed by emphasizing components in the region of 2.3MHz.

#### ■ MC44724A Block

The digital video encoder MC44724A changes the digital component signals to analog video signals (Y signal, C signal, R signal, G signal and B signal).

It is added the digital video encoder for the digital processing of CXD1854Q.

## 8. PANEL FACILITIES AND SPECIFICATIONS

### ■ Front panel

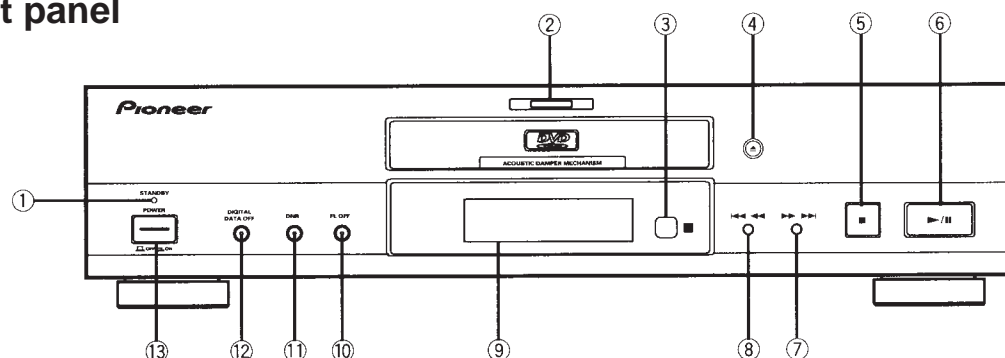

- ① STANDBY indicator (STANDBY)
- ② Disc illumination  
Turned off when a disc other than a DVD is played back.
- ③ Remote sensor
- ④ Open/Close ▲ button
- ⑤ Stop ■ button
- ⑥ Play/Pause ►/|| button
- ⑦ Forward ►►►►► button
- ⑧ Reverse ◀◀◀◀◀ button
- ⑨ Display window
- ⑩ FL OFF indicator  
Lights when the remote control's FL DIMMER button is pressed to turn the display window off.
- ⑪ Digital Noise Reduction indicator (DNR)  
When DNR button is selected, the indicator lights up.
- ⑫ Digital output OFF (DIGITAL DATA OFF) indicator  
Lights when digital output is set to OFF.
- ⑬ POWER switch

### ■ Rear panel

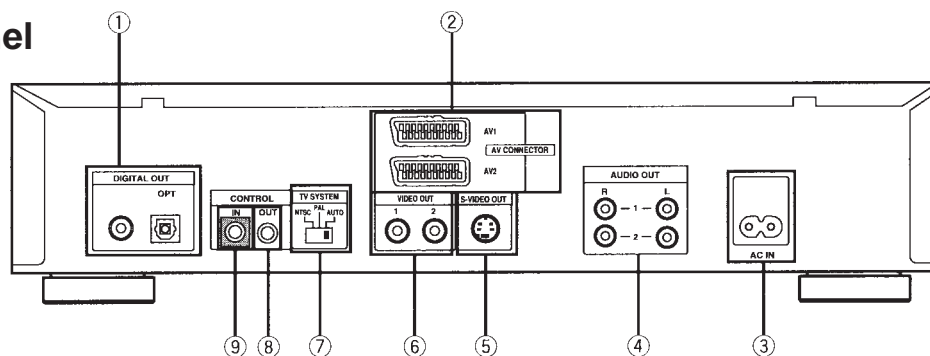

- ① Digital Output Jacks (Coaxial/OPTICAL)  
This is used for output of the digital audio signal recorded on discs.  
Set digital output to the setting suitable for the amplifier used.
- ② AV connector output jacks  
There are two terminals (1 and 2) making 2 system connections possible. Video output, S-Video output or RGB output can be selected when AV 1 is used. Output selection is done on the OUTPUT setup screen.
- ③ Power cord connection terminal
- ④ Audio output jacks\*
- ⑤ S-Video output jack
- ⑥ Video output jacks\*
- ⑦ TV system switch
- ⑧ Control output jack
- ⑨ Control input jack

\* There are two sets of outputs, 1 and 2, which you can simultaneously connect. Connect 1 to the TV, and 2 to your AV amplifier.

## Remote control

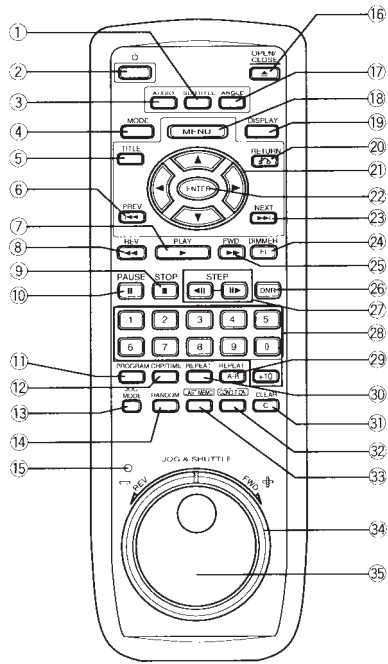

- ① Subtitle button (SUBTITLE)
- ② STANDBY/ON button (⏻)
- ③ Audio switching button (AUDIO)
- ④ Mode button (MODE)
- ⑤ ☆ Title button (TITLE)
- ⑥ ☆ Previous button (PREV ◀◀)
- ⑦ Play button (PLAY ▶)
- ⑧ Fast reverse button (REV ◀◀)
- ⑨ Stop button (STOP ■)
- ⑩ Pause button (PAUSE ||)
  
- ⑪ Program button (PROGRAM)
- ⑫ Chapter/time button (CHP/TIME)
- ⑬ Jog mode button (JOG MODE)
- ⑭ Random button (RANDOM)
- ⑮ Jog mode indicator
- ⑯ Open/Close button (OPEN/CLOSE ▲)
- ⑰ Angle button (ANGLE)
- ⑱ ☆ Menu button (MENU)
- ⑲ Display button (DISPLAY)
- ⑳ ☆ Return button (RETURN ↻)
  
- ㉑ ☆ Direction buttons (◀▶•▲•▼)
- ㉒ ☆ Enter button (ENTER)
- ㉓ ☆ Next button (NEXT ▶▶)
- ㉔ FL dimmer button (FL DIMMER)
- ㉕ Forward button (FWD ▶▶)
- ㉖ Digital noise reduction button (DNR)
- ㉗ Step buttons (STEP ◀|| / ||▶)
- ㉘ Number buttons (1-9, 0, +10)
- ㉙ Repeat A-B button (REPEAT A-B)
- ㉚ Repeat button (REPEAT)
  
- ㉛ Clear button (CLEAR)
- ㉜ Condition button (CONDITION)
- ㉝ Last Memory button (LAST MEMO)
- ㉞ Shuttle ring (SHUTTLE)
- ㉟ Jog dial (JOG)

## Display window

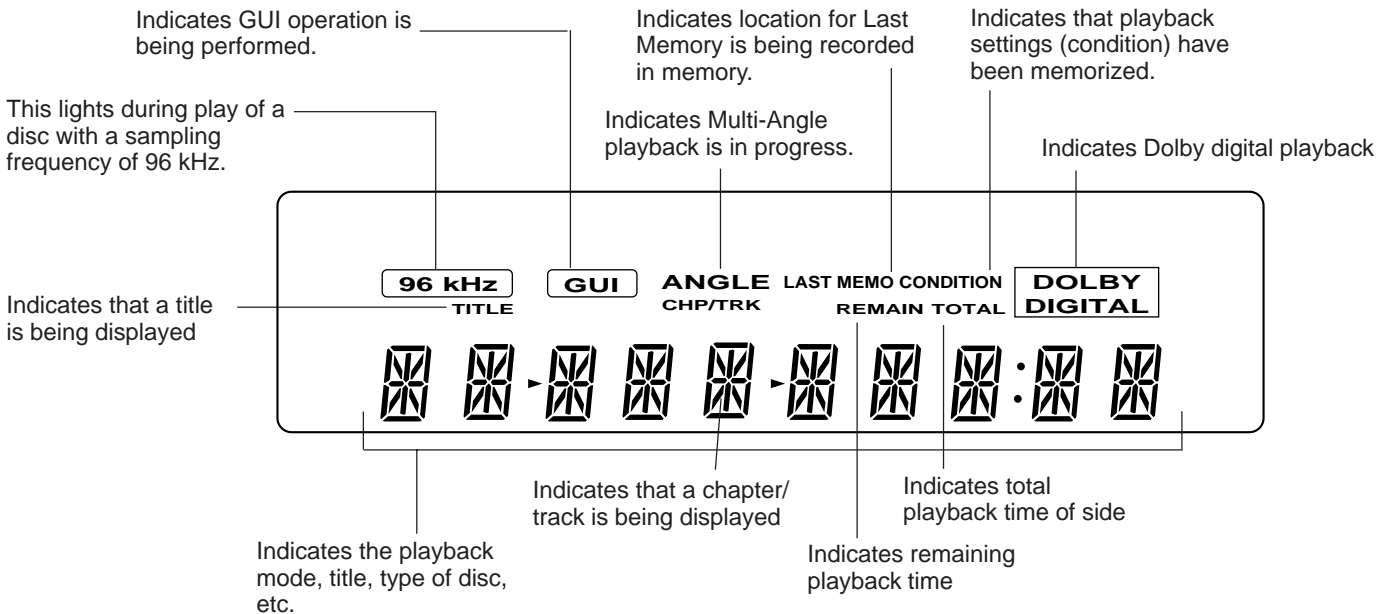



## ■ SPECIFICATIONS

### General

System ..... DVD system and Compact Disc digital audio system  
 Power requirements ..... AC 220 - 240 V, 50/60 Hz  
 Power consumption ..... 27 W  
 Power consumption in standby mode ..... 2.0 W  
 Weight ..... 6.6 kg  
 Dimensions ..... 420 (W) x 371 (D) x 128 (H) mm  
 (Not including protruding cables, etc.)  
 Operating temperature ..... +5°C to +35°C  
 Operating humidity ..... 5% to 85% (no condensation)

### S-Video Output

Y (luminance) - Output level ..... 1Vp-p (75 Ω)  
 C (color) - Output level ..... 286 mVp-p (75 Ω)  
 Jacks ..... S-VIDEO jack

### Video Output <2 system>

Output level ..... 1 Vp-p (75 Ω)  
 Jacks ..... RCA  
 AV connector input/output ..... 21-pin connector  
 This connector provides the video and audio signals for connection to a colour video TV monitor ( or TV set) which has a "AV CONNECTOR" terminal.

### 21-pin connector assignment

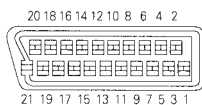

PIN no.	1 Audio 2/R out	11 G* out
	3 Audio 1/L out	15 R* or C* out
	4 GND	17 GND
	7 B* out	19 Video or Y* out
	8 Status	21 GND

\* ..... AV1 is output  
 AV2 is not output

### Audio Output <2 system>

Output level  
 During audio output ..... 200 mVrms (1 kHz, -20 dB)  
 Number of channels ..... 2  
 Jacks ..... RCA

### Digital audio characteristics (DVD fs: 96 kHz/24 bit)

Frequency response	4 Hz to 44 kHz (DVD fs: 96 kHz)
S/N ratio	115 dB
Dynamic range	103 dB
Total harmonic distortion	0.002 %
Wow and flutter	Limit of measurement (±0.001% W. PEAK) or lower

### Other Terminals

Optical digital output ..... Optical digital jack  
 Coaxial digital output ..... RCA jack  
 CONTROL IN/OUT ..... Minijack (3.5ø)

### Accessories

Remote control unit ..... 1  
 AA (R6P) dry cell batteries ..... 2  
 Audio cord ..... 1  
 Video cord ..... 1  
 Power cord ..... 1  
 Operating Instructions ..... 1  
 Warranty card (Region number ② and ⑤ models only.) ..... 1

### NOTE:

The specifications and design of this product are subject to change without notice, due to improvement.

"Dolby, Digital (AC-3)" and the double-D symbol are trademarks of Dolby Laboratories Licensing Corporation.

## ■ Accessories

Audio cord (VDE1033)  
 (L=1.5m)

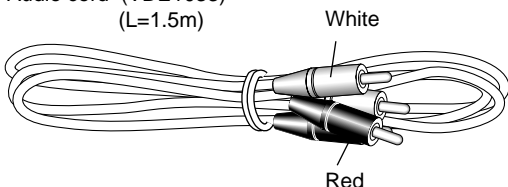

Video cord (VDE1048)  
 (L=1.5m)

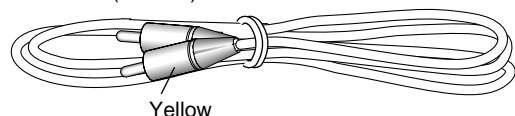

Power cord (ADG1127)

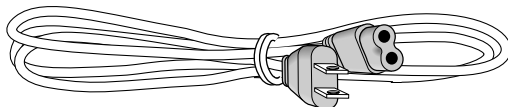

Remote control unit (VXX2601)  
 (CU-DV025)

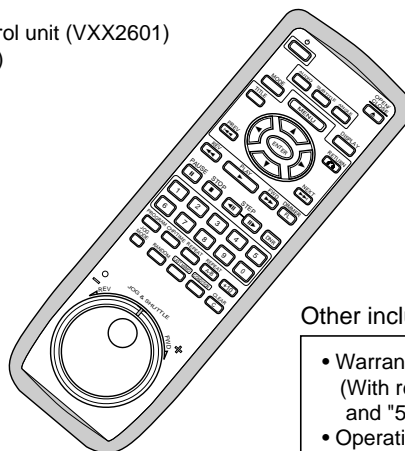

Other included items :

- Warranty card (With region No."2" and "5" models only)
- Operating instructions

Batteries (R6P,AA) .... 2

