

Panasonic

DVD Home Theater Sound System

Operating Instructions

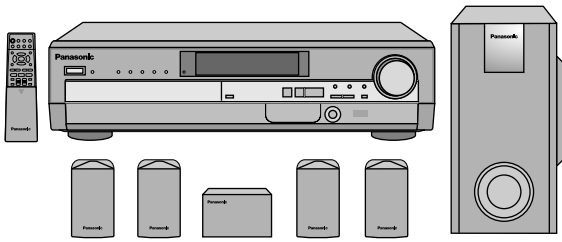

The illustration shows SC-HT75.

Model No. **SC-HT95**
SC-HT75



Before connecting, operating or adjusting this product, please read these instructions completely.

Please keep this manual for future reference.



As an ENERGY STAR® Partner, Panasonic has determined that this product meets the ENERGY STAR® guidelines for energy efficiency.

This unit responds to the region number information on DVD-Video. The unit can only play DVD-Video if the region number of the disc matches the region number of this unit. See page 5 for details.

For U.S.A. only

The servicer list and warranty can be found on pages 38 and 39.

CAUTION!

THIS PRODUCT UTILIZES A LASER.
USE OF CONTROLS OR ADJUSTMENTS OR PERFORMANCE OF PROCEDURES OTHER THAN THOSE SPECIFIED HEREIN MAY RESULT IN HAZARDOUS RADIATION EXPOSURE.
DO NOT OPEN COVERS AND DO NOT REPAIR YOURSELF. REFER SERVICING TO QUALIFIED PERSONNEL.

WARNING:

TO REDUCE THE RISK OF FIRE, ELECTRIC SHOCK OR PRODUCT DAMAGE, DO NOT EXPOSE THIS APPARATUS TO RAIN, MOISTURE, DRIPPING OR SPLASHING AND THAT NO OBJECTS FILLED WITH LIQUIDS, SUCH AS VASES, SHALL BE PLACED ON THE APPARATUS.

CAUTION!

- DO NOT INSTALL, OR PLACE THIS UNIT, IN A BOOK-CASE, BUILT-IN CABINET OR IN ANOTHER CONFINED SPACE. ENSURE THE UNIT IS WELL VENTILATED. TO PREVENT RISK OF ELECTRIC SHOCK OR FIRE HAZARD DUE TO OVERHEATING, ENSURE THAT CURTAINS AND ANY OTHER MATERIALS DO NOT OBSTRUCT THE VENTILATION VENTS.
- DO NOT OBSTRUCT THE UNIT'S VENTILATION OPENINGS WITH NEWSPAPERS, TABLECLOTHS, CURTAINS, AND SIMILAR ITEMS.
- DO NOT PLACE SOURCES OF NAKED FLAMES, SUCH AS LIGHTED CANDLES, ON THE UNIT.
- DISPOSE OF BATTERIES IN AN ENVIRONMENTALLY FRIENDLY MANNER.

THE FOLLOWING APPLIES ONLY IN THE U.S.A. AND CANADA:

CAUTION:

TO PREVENT ELECTRIC SHOCK MATCH WIDE BLADE OF PLUG TO WIDE SLOT, FULLY INSERT.

For units with PX printed on the outer packaging THIS UNIT IS INTENDED FOR USE IN MODERATE CLIMATES.

For Latin America

THIS UNIT IS INTENDED FOR USE IN TROPICAL CLIMATES.

For areas except U.S.A. and Canada

CAUTION:

The AC voltage is different according to the area.
Be sure to set the proper voltage in your area before use.
(For details, please refer to page 9.)

DANGER	- VISIBLE AND INVISIBLE LASER RADIATION WHEN OPEN. AVOID DIRECT EXPOSURE TO BEAM. (FDA 21 CFR)
CAUTION	- VISIBLE AND INVISIBLE LASER RADIATION WHEN OPEN. AVOID EXPOSURE TO BEAM. (IEC60825-1)
ATTENTION	- RAYONNEMENT LASER VISIBLE ET INVISIBLE EN CAS D'OUVERTURE. EXPOSITION DANGEREUSE AU FAISCEAU.
ADVARSEL	- SYNLIG OG USYNLIG LASERSTRÅLING VED ÅBNING. UNNGÅ EKSPONERING FOR STRÅLEN.
VARO!	- AVATTAESSA OLET ALLTIIN NÄKYVÄÄ JA NÄKYMÄTÖN LASERSÄTEILYLLÄ. ÄLÄ KATSO SÄTEESEEN.
VARNING	- SYNLIG OCH OSYNLIG LASERSTRÅLING NÄR DENNA DEL ÄR ÖPPNAD. BETRÄKTA EJ STRÅLEN.
ADVARSEL	- SYNLIG OG USYNLIG LASERSTRÅLING NÄR DEKSEL ÅPNES. UNNGÅ EKSPONERING FOR STRÅLEN.
VORSICHT	- SICHTBARE UND UNSICHTBARE LASERSTRÄHLUNG, WENN ABDECKUNG GEÖFFNET. NICHT DEM STRAHL AUSSETZEN.
注意	- 打开时有可见及不可见激光辐射。避免激光束照射。
注意	- ここを開くと可視及び不可視のレーザー光が出ます。ビームを直接見たり、触れたりしないでください。 RQLS0233

(Inside of product)

THE FOLLOWING APPLIES ONLY IN THE U.S.A.:

CAUTION:

This equipment has been tested and found to comply with the limits for a Class B digital device, pursuant to Part 15 of the FCC Rules.

These limits are designed to provide reasonable protection against harmful interference in a residential installation. This equipment generates, uses and can radiate radio frequency energy and, if not installed and used in accordance with the instructions, may cause harmful interference to radio communications. However, there is no guarantee that interference will not occur in a particular installation. If this equipment does cause harmful interference to radio or television reception, which can be determined by turning the equipment off and on, the user is encouraged to try to correct the interference by one or more of the following measures:

- Reorient or relocate the receiving antenna.
- Increase the separation between the equipment and receiver.
- Connect the equipment into an outlet on a circuit different from that to which the receiver is connected.
- Consult the dealer or an experienced radio/TV technician for help.

Any unauthorized changes or modifications to this equipment would void the user's authority to operate this device.

This device complies with Part 15 of the FCC Rules. Operation is subject to the following two conditions: (1) This device may not cause harmful interference, and (2) this device must accept any interference received, including interference that may cause undesired operation.

THE FOLLOWING APPLIES ONLY IN THE U.S.A. AND CANADA:

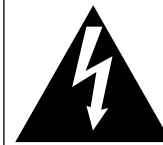
**CAUTION**

RISK OF ELECTRIC SHOCK
DO NOT OPEN



CAUTION: TO REDUCE THE RISK OF ELECTRIC SHOCK, DO NOT REMOVE SCREWS. NO USER-SERVICEABLE PARTS INSIDE. REFER SERVICING TO QUALIFIED SERVICE PERSONNEL.

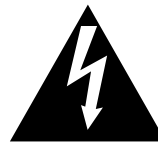

The lightning flash with arrowhead symbol, within an equilateral triangle, is intended to alert the user to the presence of uninsulated "dangerous voltage" within the product's enclosure that may be of sufficient magnitude to constitute a risk of electric shock to persons.



The exclamation point within an equilateral triangle is intended to alert the user to the presence of important operating and maintenance (servicing) instructions in the literature accompanying the appliance.

For areas except U.S.A. and Canada

CLASS 1
LASER PRODUCT

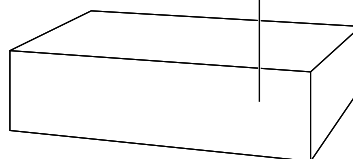

(Back of product)

Dear customer

Thank you for purchasing this product.
For optimum performance and safety, please read these instructions carefully.

System	SC-HT95	SC-HT75
Main unit	SA-HT95	SA-HT75
Front speakers	SB-AFC286	SB-AFC95
Center speaker	SB-AFC286	SB-PC89
Surround speakers	SB-AFC95	SB-AFC95
Subwoofer	SB-W81	SB-W95

- These operating instructions are applicable to models SC-HT95 and SC-HT75. Unless otherwise indicated, illustrations in these operating instructions are of SC-HT75.
- Operations in these instructions are described mainly with the remote control, but you can do the operations on the main unit if the controls are the same.

HT95: indicates features applicable to SC-HT95 only.
HT75: SC-HT75 only.

Accessories



Please check and identify the supplied accessories. Use numbers indicated in parentheses when asking for replacement parts.

(Only for U.S.A.)

To order accessories contact 1-800-332-5368 or web site (<http://www.panasonic.com>).

(For other areas)

To order accessories, call the dealer from whom you have made your purchase.

- 1 Remote control (EUR7502XF0)

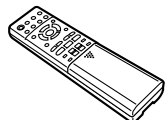

- 1 AC power supply cord
For U.S.A. and Canada
(RJA0065-1D)

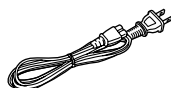

- 2 Batteries for remote control

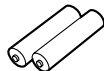

- For others**
(RJA0019-2X)

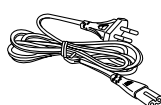

- 1 Video cable (RJL1P016B15A)



- 1 Sheet of speaker feet (RFA0631A-K)
Replacements sold in sets of 4.

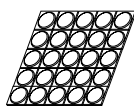

- 1 AM loop antenna set (RSA0012)

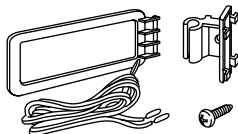

- 1 FM indoor antenna (RSA0006-J)



- 1 Sheet of speaker-cord stickers (12 stickers)
One set is extra.
The sheet cannot be purchased separately.

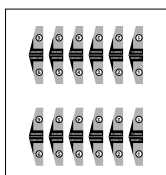

For areas except U.S.A. and Canada

- 1 Power plug adaptor (SJP5213-2)

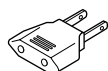

Table of contents

Getting started

Accessories	3
IMPORTANT SAFETY INSTRUCTIONS	4
Disc information	5
Disc handling	5
Simple setup	
STEP 1 Locating and connecting the speakers ..	6
STEP 2 Television	8
STEP 3 Antennas and AC power supply cord ..	9
STEP 4 The remote control	10
STEP 5 Selecting TV screen type	10
Control reference guide	11

Disc operations

Discs—Basic play	12
Playing MP3	13
Resume function	13
Skipping chapters or tracks	13
Fast forward and rewind—SEARCH	13
Slow-motion play/Frame-by-frame viewing	13
Starting play from a selected track	14
Disc skip/Cinema/Marking places to play again—MARKER ..	14
Using the disc manager	15
Selecting groups to play	15
Selecting still pictures—Page Skip	15
Discs—Convenient functions	16
A-B repeat play/Repeat play	16
All group play/Program play/Random play/All disc random play ..	17
Changing soundtracks, subtitle languages and angles	18
Soundtracks/Subtitles/Angles	18
Using On-Screen Menu Icons	19
Common procedures	19
Disc information/Unit information	20
Shuttle screen	21

Radio operations

The radio: manual tuning	22
The radio: preset tuning	23

Sound quality/sound field operations

Sound field	24
DOLBY DIGITAL and DTS/DOLBY PRO LOGIC	25
Changing sound field and quality	25
SUPER SURROUND/SEAT POSITION/CENTER FOCUS ..	26
Adjusting the bass	26

Other functions

Convenient functions	27
Muting the volume/Turning off the display	27
Timer functions	27
Using headphones	27
Changing settings	28
Common procedures	29
Entering a password (Ratings)/Changing the delay time ..	29
Using the remote control with other equipment ..	30
Operating a television/Operating a video cassette recorder ..	30
Changing the remote control code	31
Listening to an external source/ Recording to other equipment	32
Optional antenna connections	33

Reference

Troubleshooting guide	34
Maintenance	35
Glossary	36
Language code list	36
Specifications	37
Servicenter List (U.S.A.)	38
Limited Warranty (U.S.A.)	39
Product Service (U.S.A. and Canada)	39

IMPORTANT SAFETY INSTRUCTIONS

Read these operating instructions carefully before using the unit. Follow the safety instructions on the unit and the safety precautions listed below. Keep these operating instructions handy for future reference.

Getting started

Safety

1. **Power source**—Connect the unit to a power source of the type described in these instructions or as marked on the unit.
2. **Polarization**—The unit is equipped with a polarized power plug where one blade is wider than the other. This safety feature ensures that the plug fits into your household AC outlet only one way. If the plug doesn't fit one way, try reversing it. If the plug still doesn't fit, contact an electrician to replace the obsolete outlet. Do not attempt to defeat the safety purpose of the plug.
3. **Power cord protection**—Route the AC power supply cord so that it will not be walked on or pinched by items placed on or against it. Never take hold of the plug or cord with wet hands. Always grasp the plug body firmly when connecting and disconnecting it.
4. **Overloading**—When connecting the AC power supply cord, be careful not to overload the household AC outlet, extension cord, or outlet from any other device as this can result in fire or electric shock.
5. **Nonuse periods**—Turn the unit off when it is not in use. Unplug the unit from the household AC outlet if it is not to be used for a long time. Unplug the unit during lightning storms.
6. **Attachments and accessories**—Use only the attachments and accessories recommended in these operating instructions.

Installation

Placement

1. **Ventilation**—Situate the unit so that it receives proper ventilation. Do not install in a confined space such as a bookcase or cabinet. Allow at least 10 cm (4 inches) clearance from the rear of the unit. To prevent the risk of electric shock or fire due to overheating ensure curtains and other materials do not obstruct the unit's ventilation.
2. **Foreign material**—Ensure objects and liquids do not get into the unit. Avoid exposing the unit to excessive smoke, dust, mechanical vibration, and shock.
3. **Magnetism**—Situate the unit away from equipment and devices that generate strong magnetic fields.
4. **Stacking**—Do not place heavy objects on top of this unit.
5. **Surface**—Place the unit on a flat, level surface.
6. **Carts and stands**—Use the unit only with carts and stands recommended by the manufacturer. Move carts with care. Sudden stops, excessive force, and uneven surfaces can cause carts to overturn.
7. **Wall and ceiling mounting**—Do not mount the unit on walls or ceilings unless specified in the instructions.



Environment

1. **Water and moisture**—Do not use the unit near water, such as near a bathtub or swimming pool. Avoid damp basements.
2. **Heat**—Situate the unit away from heat sources, such as radiators.
Do not situate where temperatures fall below 5°C (41°F) or rise above 35°C (95°F).

Item 2 in "Safety" applies only in the U.S.A. and Canada.

3. **Power lines**—Take care when setting up an outdoor antenna that it is not near overhead power lines, electric lights, or electrical circuits, and that there is no danger of the antenna falling on power lines, electric lights, or electrical circuits. When installing an outdoor antenna, take extreme care not to touch such power lines or circuits, as contact with them can be fatal.
4. **Outdoor antenna grounding**—If you connect an outdoor antenna, ground the antenna system to protect against voltage surges and built-up static charges. Section 810 of the National Electrical Code, ANSI/NFPA No. 70-1990, provides information about grounding of the mast and supporting structure, grounding of the lead-in wire to an antenna discharge unit, size of grounding conductors, location of antenna-discharge unit, connection to grounding electrodes, and requirements for the grounding electrode. Refer to this diagram.

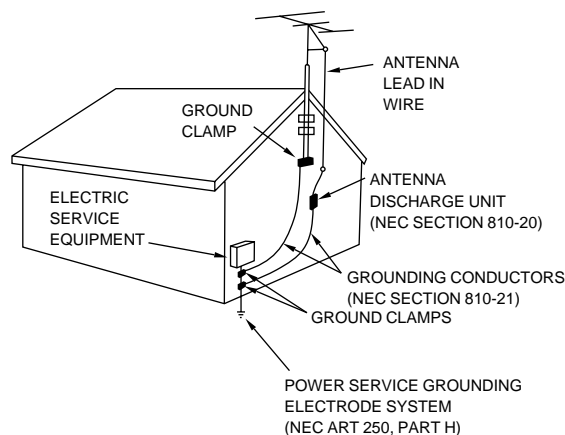

NEC—NATIONAL ELECTRICAL CODE

Maintenance

(See page 35 for details.)

Unplug the unit from the household AC outlet before cleaning.
Clean with a damp cloth.
Do not use abrasive pads, scouring powders, or solvents.

Service

1. **Damage requiring service**—The unit should be serviced by qualified service personnel if:
 - (a) The AC power supply cord or the plug has been damaged; or
 - (b) Objects or liquids have gotten into the unit; or
 - (c) The unit has been exposed to rain; or
 - (d) The unit does not operate normally or exhibits a marked change in performance; or
 - (e) The unit has been dropped or the cabinet damaged.
2. **Servicing**—Do not attempt to service the unit beyond that described in these operating instructions. Refer all other servicing to authorized servicing personnel.
3. **Replacement parts**—When parts need replacing ensure the servicer uses parts specified by the manufacturer or parts that have the same characteristics as the original parts. Unauthorized substitutes may result in fire, electric shock, or other hazards.
4. **Safety check**—After repairs or service, ask the servicer to perform safety checks to confirm that the unit is in proper working condition.

Disc information

Discs that can be played

Disc type	Logo	Indication used in instructions
DVD-Audio		DVD-A
DVD-Video		DVD-V
DVD-R		
Audio CD		CD (Including CD-R/RW and discs recorded with MP3)
Video CD		VCD

Discs that cannot be played

PAL discs (the audio on DVD-Audio can be played), DVD-ROM, DVD-RAM, CD-ROM, CDV, CD-G, +RW, DVD-RW, CVD, SVCD, SACD, Divx Video Discs and Photo CD.

Region Management Information (DVD-Video only)

This unit responds to the Region Management Information recorded on DVD-Video. You cannot play the disc if the region number on the DVD-Video does not correspond to the region number on the unit. Read the disc's instructions carefully.

For U.S.A., Canada, and units with PX printed on the outer packaging

- The region number of this unit is "1".
- You can play discs with labels containing the region number "1" and "ALL".



For Latin America

- The region number of this unit is "4".
- You can play discs with labels containing the region number "4" and "ALL".



Playing DVDs and Video CDs

The producer of these discs can control how they are played so you may not always be able to control play as described in these operating instructions. Read the disc's instructions carefully.

CD-R and CD-RW discs

This unit can play CD-DA (digital audio) and video CD format audio CD-R and CD-RW that have been finalized (a process that enables CD-R/CD-RW players to play audio CD-R and CD-RW) upon completion of recording.

It may not be able to play some CD-R or CD-RW due to the condition of the recording.

DVD-R discs

Panasonic DVD-R recorded and finalized on a Panasonic DVD video recorder are played as DVD-Video on this unit.

It may not be possible to play these discs in all cases due to the type of disc or condition of the recording.

Disc handling

Do not use irregularly shaped discs, such as heart-shaped. (These can damage the unit.)

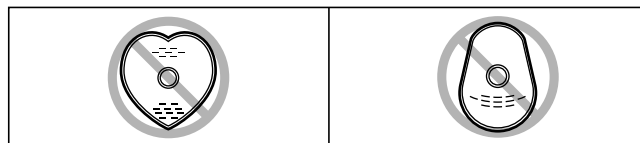

How to hold a disc

Do not touch the recorded surface.

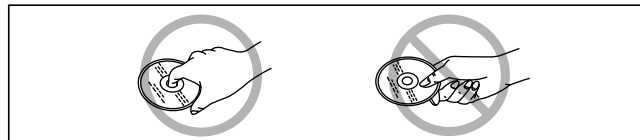

If the surface is dirty

Wipe it with a damp cloth and then wipe dry.

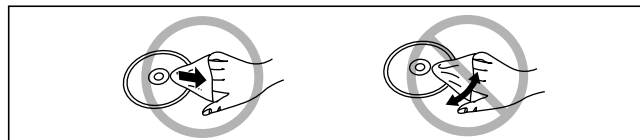

If the disc is brought from a cold to a warm environment, moisture may form on the disc

Wipe with a soft, dry, lint-free cloth before using the disc.

Handling precautions

- Do not write on the label side with a ball-point pen or other writing instrument.
- Do not use record cleaning sprays, benzene, thinner, static electricity prevention liquids or any other solvent.
- Do not attach labels or stickers to discs. (Do not use discs with exposed adhesive from tape or left over peeled-off stickers.)
- Do not use scratch-proof protectors or covers.
- Do not use discs printed with label printers available on the market.

Do not place or store discs in the following places

- Locations exposed to direct sunlight
- Humid or dusty locations
- Locations directly exposed to a heat vent or heating appliance

To prevent damage

- Load only 1 disc per tray.

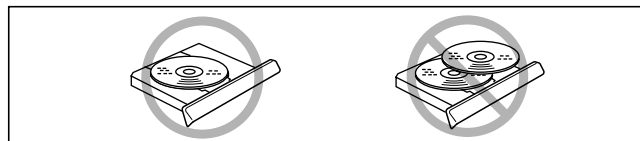

- Load discs as shown in figure.

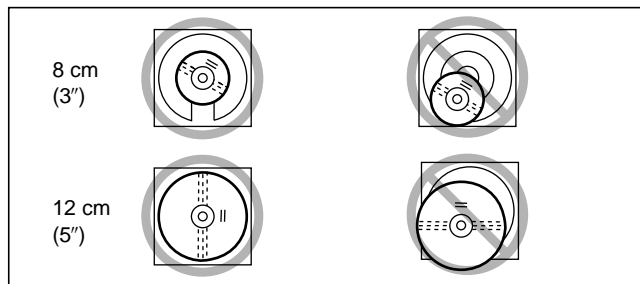

- An adaptor is not needed with 8 cm (3") discs (singles).
- Set the system on a flat, level surface. Do not set it on top of magazines, inclined surfaces, etc.
- Do not move the system while trays are opening/closing, or when loaded.
- Do not put anything except discs in trays.
- Do not use cleaning discs or discs which are badly warped or cracked.

Simple setup

Refer also to "Speaker setup", a separate guide included with these operating instructions.

STEP 1 Locating and connecting the speakers

Use only supplied speakers

Using other speakers can damage the unit and sound quality will be negatively affected.

Set the speakers up on an even surface to prevent them from falling. Take proper precautions to prevent the speakers from falling if you cannot set them up on an even surface.

Front speakers (① Left ② Right)

HT95

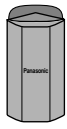

SB-AFC286

HT75



SB-AFC95

- The left and right speakers are the same.
- You can rotate the brand plate of SB-AFC286 vertically.

Center speaker (⑤)

HT95

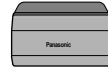

SB-AFC286

HT75



SB-PC89

- You can also put this speaker directly under the television.
- Do not place the center speaker on the main unit as sound quality will be affected.
- Vibration caused by the center speaker can disrupt the picture if it is placed directly on the television. Put the center speaker on a rack or shelf.

Main unit

Keep your speakers at least 10 mm (13/32") away from the system for proper ventilation.

Subwoofer (⑥) HT95 SB-W81 HT75 SB-W95

Place near the television, on the floor or a sturdy shelf so that it won't cause vibration.

HT75

- A woofer unit is located on the side of the subwoofer. Leave 10-cm (4") clearance for it to be effective.

Place the front, center, and surround speakers at approximately the same distance from the seating position. The angles in the diagram are approximate.

Surround speakers (③ Left ④ Right) SB-AFC95

Place either side of listening position, or slightly to the rear, about 1 meter (3 feet) higher than ear level.

- The left and right speakers are the same.

Attaching the speaker feet

Attach these speaker feet to prevent vibration causing the speakers to move or fall over.

Standing

Front (①②)/surround (③④) speakers

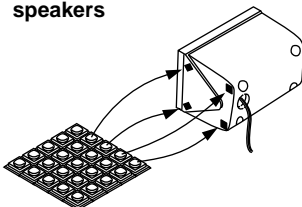

Laying down

Center speaker (⑤)

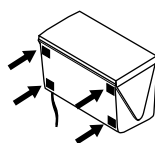

Positioning for best effect

How you set up your speakers can affect the bass and the sound field. Note the following points.

- Place speakers on flat secure bases.
- Placing speakers too close to floors, walls, and corners can result in excessive bass. Cover walls and windows with thick curtain.

Caution

- Use the speakers only with the recommended system. Failure to do so may lead to damage to the amplifier and/or the speakers, and may result in the risk of fire. Consult a qualified service person if damage has occurred or if you experience a sudden change in performance.
- Do not attempt to attach these speakers to walls using methods other than those described in this manual.



If irregular coloring occurs on your television

These speakers are designed to be used close to a television, but the picture may be affected with some televisions and setup combinations.

If this occurs, turn the television off for about 30 minutes.

The television's demagnetizing function should correct the problem. If it persists, move the speakers further away from the television.

Speaker cords

Attach the stickers to the speaker cords.

- Attach the numbered stickers to the end of the speaker cords so the numbers match the positions of the speakers shown in the diagram.

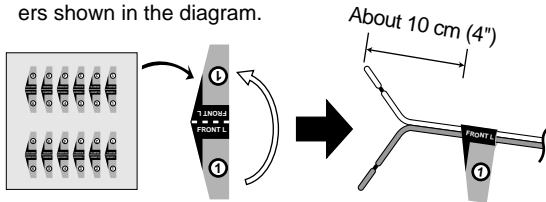

- Connect the cords to the terminals of same color so the numbers on the stickers match the numbers under the terminals.
- Never short-circuit positive (+) and negative (-) speaker wires.
- Be sure to connect only positive (red or gray) wires to positive (+) terminals and negative (black or gray with blue stripe) wires to negative (-) terminals. Incorrect connection can damage the speakers.
- After you have completed setup and connection, wind the excess cord and keep together with string.
- The speaker nets cannot be removed.

Notes on speaker use

- You can damage your speakers and shorten their useful life if you play sound at high levels over extended periods.

Reduce the volume in the following cases to avoid damage.

- When playing distorted sound.
- When the speakers are receiving howling from a microphone or record player, noise from FM broadcasts, or continuous signals from an oscillator, test disc, or electronic instrument.
- When adjusting the sound quality.
- When turning the unit on or off.

Twist the vinyl tip and pull off.

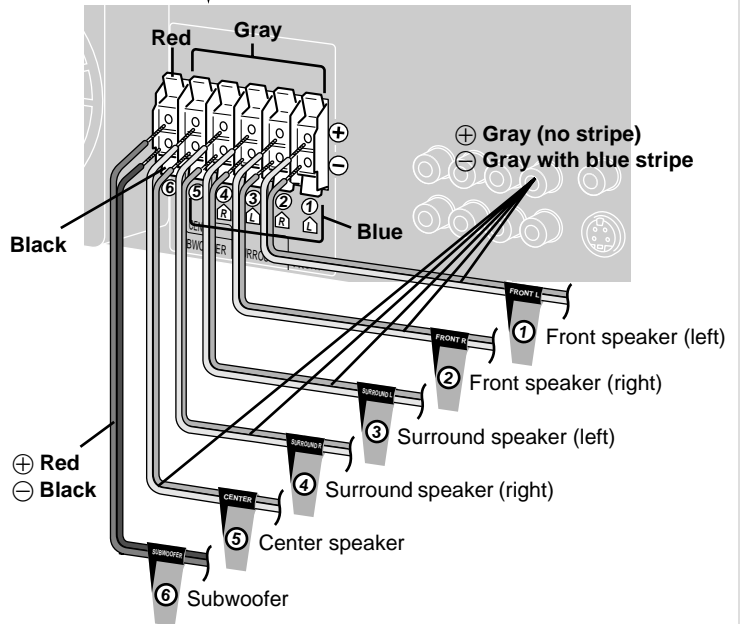
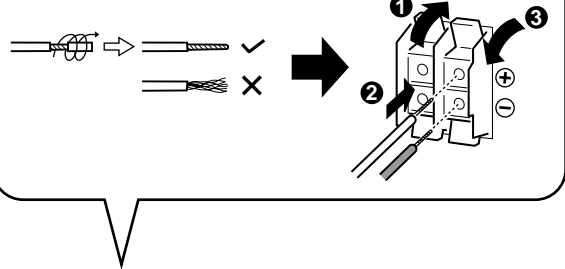

Attaching to a wall

Front and surround speakers can be attached to a wall. Attach four speaker feet to each speaker, ensuring they do not cover the holes. Set the speaker onto screws and slide through bracket to lock into position.

HT95

Speaker feet (included)

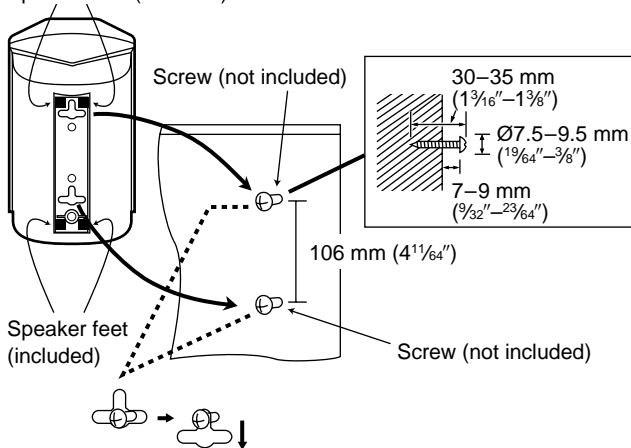

HT75

The method for attaching speakers to a wall is the same except that there is only one bracket.

Note

The wall or pillar on which the speakers are to be attached should be capable of supporting 10 kg (22 lb.) for SB-AFC286 and 5 kg (11 lb.) for SB-AFC95 per screw.

Attaching to speaker stands

Ensure the following conditions are met when you purchase your speaker stands.

- Observe the diameter and length of the screws and the distance between screws as shown in the diagram.
- The stands must be able to support over 10 kg (22 lb.) for SB-AFC286 and 5 kg (11 lb.) for SB-AFC95.
- The stands must be stable even if the speakers are in a high position.

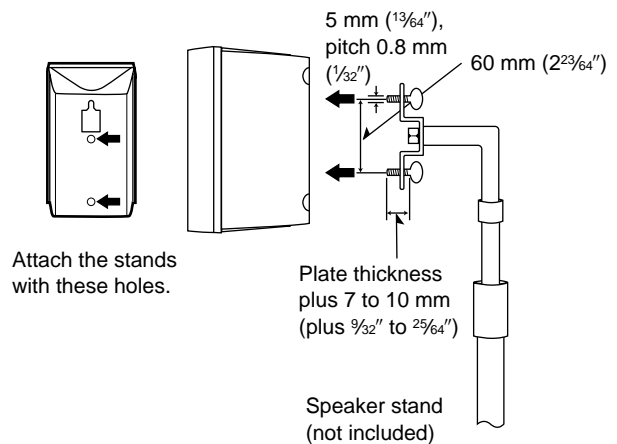

Simple setup

STEP 2 Television

The illustration shows SC-HT95.

Connect directly to your television.

Do not connect the unit through a video cassette recorder, because the picture may not be played correctly due to the copy guard.

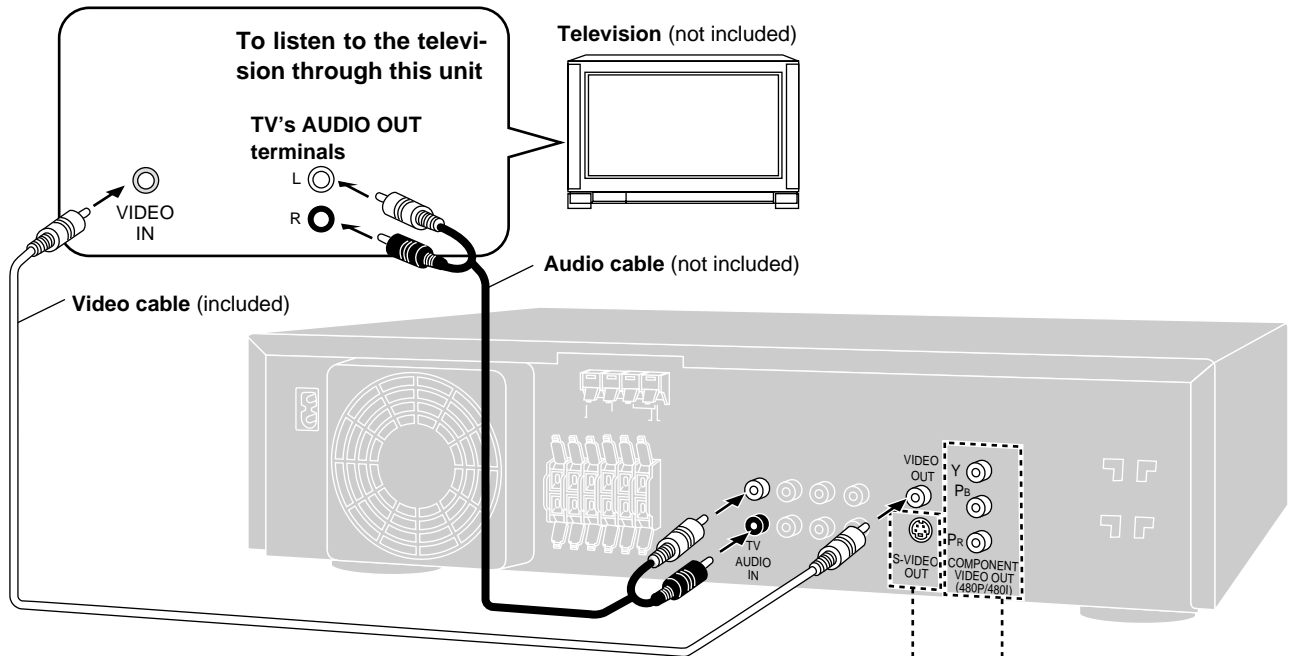

For better images

S-VIDEO OUT terminal

The S-VIDEO OUT terminal achieves a more vivid picture than the VIDEO OUT terminal by separating the chrominance (C) and luminance (Y) signals before transmitting them to the television.

(Actual results depend on the television.)

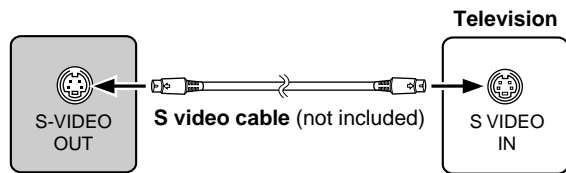

For better images

HT95

COMPONENT VIDEO OUT terminal (see below)

These terminals can be used for either interlace or progressive output and provide a purer picture than the S-VIDEO OUT terminal. Connection using these terminals outputs the color difference signals (P_B/P_R) and luminance signal (Y) separately in order to achieve high fidelity in reproducing colors.

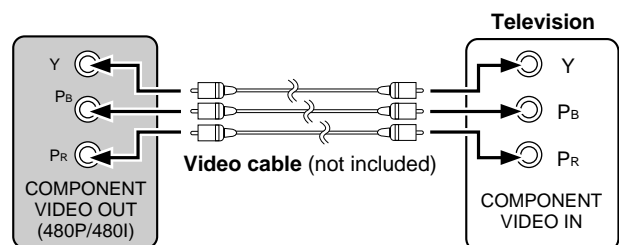

HT95

COMPONENT VIDEO OUT terminal

- The description of the component video input terminals depends on the television or monitor (e.g. Y/P_B/P_R, Y/B-Y/R-Y, Y/C_B/C_R). Connect to terminals of the same color.
- After making this connection, change the black level for a better picture (➔ page 28, Video—Black Level Control).

To enjoy progressive video

1. Connect to the component video (480p) input terminals on a television compatible with this unit's copy guard system.
2. Press [PROGRESSIVE OUT] on the front panel so the indicator lights (➔ page 12).

NOTE

This unit does not output video signals from the VIDEO OUT and S-VIDEO OUT terminals when the "PROGRESSIVE OUT" indicator is on.

Note

- The screen may shift off center when using progressive output. Adjust the position of the screen if this occurs (➔ page 21, Video—Horizontal position).
- Video will not be displayed correctly if you connect to a television that is incompatible with this unit's copy guard system.
- This unit does not output video signals from the VIDEO OUT and S-VIDEO OUT terminals when the "PROGRESSIVE OUT" indicator is on.

For your reference

All televisions manufactured by Panasonic and that have 480p input terminals are compatible. Consult the manufacturer if you have another brand of television.

STEP 3

Antennas and AC power supply cord

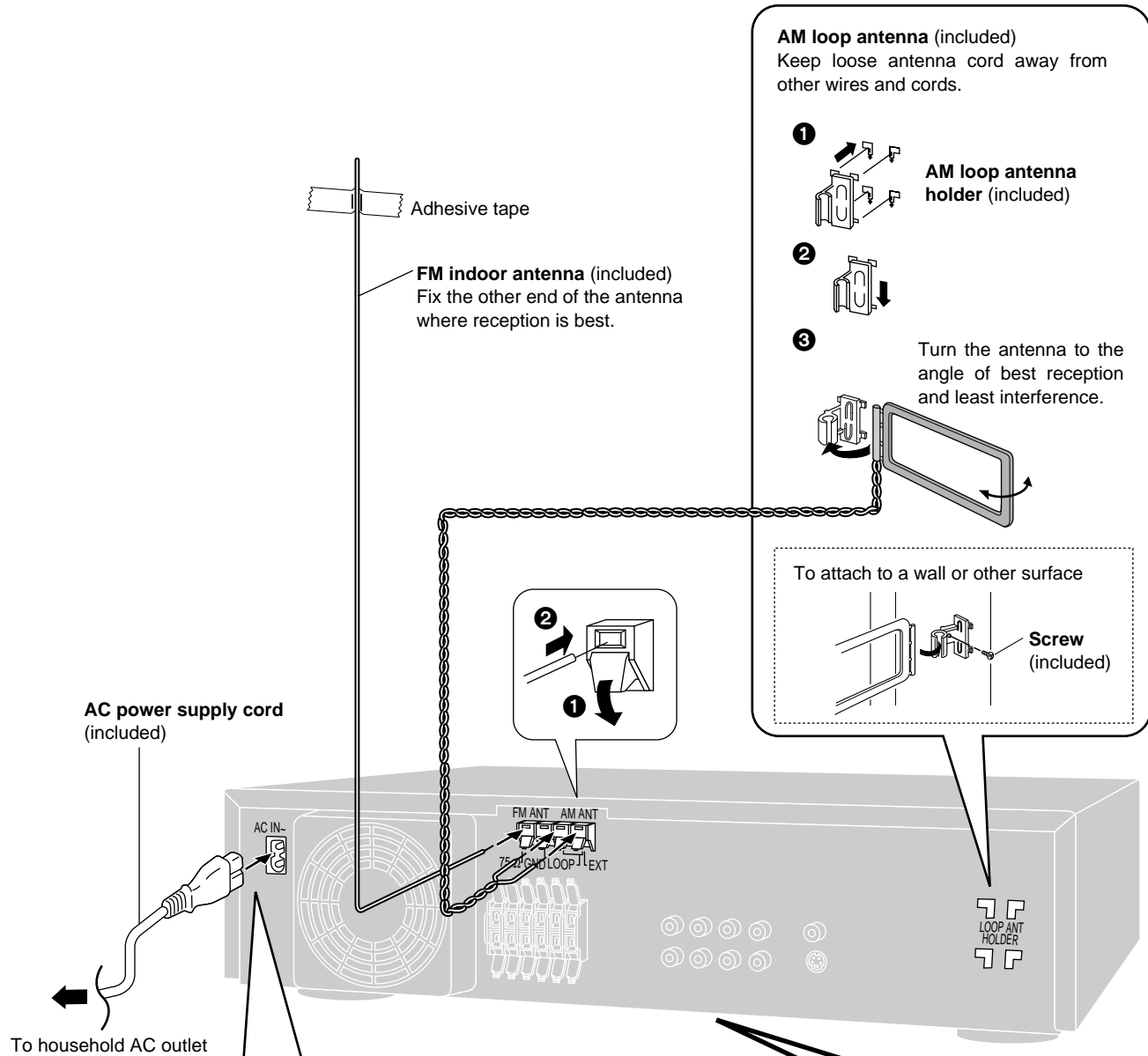

AM loop antenna (included)
Keep loose antenna cord away from other wires and cords.

- AM loop antenna holder (included)**
-
- Turn the antenna to the angle of best reception and least interference.

To attach to a wall or other surface

Screw (included)

Note
The included AC power supply cord is for use with this unit only. Do not use it with other equipment.

Conserving power
The unit consumes power (for U.S.A. and Canada: approx. 0.28 W, for Latin America and others: approx. 0.8 W) even when it is turned off with [⏻]. To save power when the unit is not to be used for a long time, unplug it from the household AC outlet. Remember to reset the radio stations and any other memory items before using the unit again.

For your reference
Information you enter into the unit's memory remains intact for up to a week after the AC power supply cord is disconnected.

For areas except U.S.A. and Canada
If the power plug will not fit your AC outlet
Use the power plug adaptor (included).

If it still doesn't fit, contact an electrical parts distributor for assistance.

For areas except U.S.A. and Canada
Before connecting the AC power supply cord

Set the voltage.
(Bottom panel)

VOLT ADJ

Use a flat-head screwdriver to turn the voltage selector on the bottom of the unit to the appropriate position for the area in which this system is used.

If the power supply in your area is 115 V or 120 V, please set the voltage selector as follows:

- For 115 V: Set to 110 V.
- For 120 V: Set to 127 V.

Simple setup

STEP 4 The remote control

■ Batteries

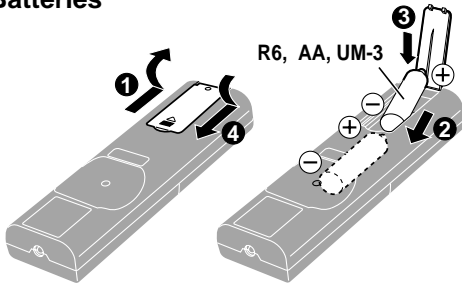

- Insert so the poles (+ and -) match those in the remote control.
- Do not use rechargeable type batteries.

Do not;

- mix old and new batteries.
 - use different types at the same time.
 - heat or expose to flame.
 - take apart or short circuit.
 - attempt to recharge alkaline or manganese batteries.
 - use batteries if the covering has been peeled off.
- Mishandling of batteries can cause electrolyte leakage which can damage items the fluid contacts and may cause a fire.

Remove if the remote control is not going to be used for a long period of time. Store in a cool, dark place.

■ Use

Aim at the sensor, avoiding obstacles, at a maximum range of 7 m (23 feet) directly in front of the unit.

STEP 5 Selecting TV screen type

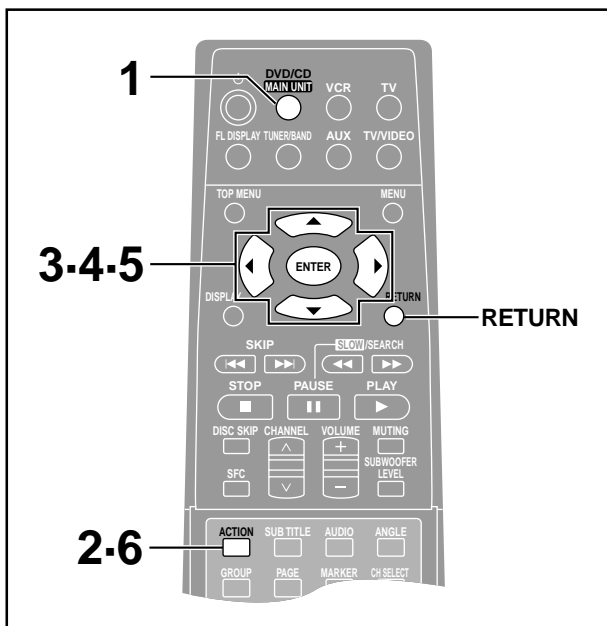

Remote control only

Change the setting to suit your television.

The menu language is set to English, but you can change it to French or Spanish (→ page 28, Display—Menu Language). English is used in the examples.

Preparation

Turn on the television and select the appropriate video input on the television to suit the connections for the unit.

- 1 Press [DVD/CD] to turn on the unit.
The unit comes on automatically and “DVD/CD” is selected as the source.
- 2 Press [ACTION] to show the menus.

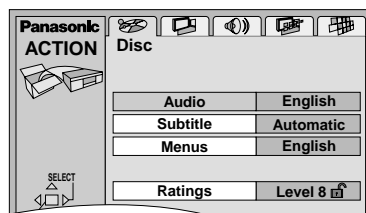

- 3 Press [◀, ▶] to select the “Video” tab.
- 4 Press [▲, ▼] to select “TV Aspect” and press [ENTER].
- 5 Press [▲, ▼] to select the item and press [ENTER].

- **4:3 Pan&Scan** (Factory preset)
Select if you have a regular television and to view 16:9 software in the pan and scan style.



16:9 software prohibited from being shown in the pan and scan style will appear in the letterbox style despite the setting here.

- **4:3 Letterbox**
Select if you have a regular television and to view 16:9 software in the letterbox style.



- **16:9**
Select if you have a widescreen (16:9) television. Use the television's screen modes to change the way the picture is shown.

- 6 Press [ACTION] to end the settings.

To return to the previous screen

Press [RETURN].

HT95

- When viewing video made for a standard 4:3 aspect television on a wide 16:9 aspect television using progressive output

This unit shows the correct aspect when playing wide 16:9 aspect software, but when showing standard 4:3 aspect software, the picture is stretched horizontally to fill the screen.

- If your television can change the aspect when input is progressive
Use the television to change the aspect to the correct one.
- If your television cannot change the aspect when input is progressive
Press [PROGRESSIVE OUT] so the “PROGRESSIVE OUT” indicator goes out. Output will now be interlace.

NOTE

This unit does not output video signals from the VIDEO OUT and S-VIDEO OUT terminals when the “PROGRESSIVE OUT” indicator is on.

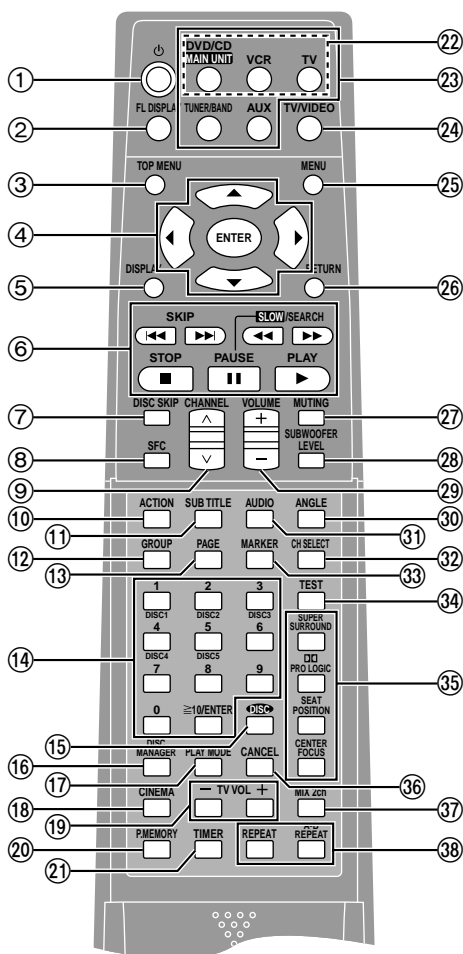

①	Power button [⏻]	12
②	FL display button [FL DISPLAY]	27
③	Top menu button [TOP MENU]	12
④	Cursor buttons [▲, ▼, ◀, ▶]/Enter button [ENTER]	10
⑤	Display button [DISPLAY]	19
⑥	Basic operation buttons	
⑦	Disc skip button [DISC SKIP]	14
⑧	Sound field control button [SFC]	25
⑨	Channel select buttons [▲, ▼, CHANNEL]	23, 30
⑩	Initial settings button [ACTION]	10, 29
⑪	Subtitle button [SUB TITLE]	18
⑫	Group button [GROUP]	15
⑬	Page button [PAGE]	15
⑭	Numbered buttons (1–9, 0, ≧10/ENTER)	12
⑮	Disc button [DISC]	12
⑯	Disc manager button [DISC MANAGER]	15
⑰	Play mode button [PLAY MODE]	17
⑱	Cinema button [CINEMA]	14
⑲	TV volume buttons [– TV VOL +]	30
⑳	Position memory button [P.MEMORY]	13
㉑	Timer button [TIMER]	27
㉒	Equipment buttons and indicators Select the equipment you want to operate. ● Press [DVD/CD] to operate this unit. ● Press [VCR] to operate a video cassette recorder. ● Press [TV] to operate a television. These buttons light for a few seconds to indicate the remote control mode.	
㉓	Input select buttons [DVD/CD, MAIN UNIT, VCR, TV, TUNER/BAND, AUX] Pressing [DVD/CD] or [TUNER/BAND] also turns the unit on. [TUNER/BAND] also switches radio bands.	
㉔	TV/Video button [TV/VIDEO]	30
㉕	Menu button [MENU]	12
㉖	Return button [RETURN]	10, 29
㉗	Muting button [MUTING]	27
㉘	Subwoofer level button [SUBWOOFER LEVEL]	26
㉙	Volume buttons [+ , – , VOLUME]	12, 22
㉚	Angle button [ANGLE]	18
㉛	Audio button [AUDIO]	18
㉜	Speaker channel select button [CH SELECT]	25
㉝	Marker button [MARKER]	14
㉞	Test button [TEST]	25
㉟	Sound field and effect buttons	25, 26
㊱	Cancel button [CANCEL]	14
㊲	Mix 2ch button [MIX 2ch]	25
㊳	Repeat buttons [REPEAT, A-B REPEAT]	16

How to open the remote control

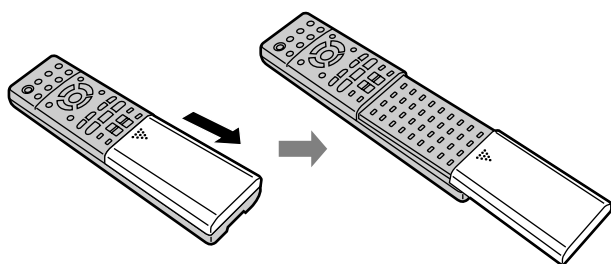

HT95

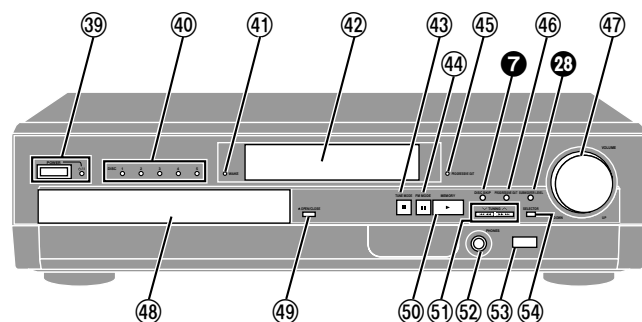

Buttons ⑦ and ㉓ function the same as the controls on the remote control.

Main unit

㉑	Standby/on switch [POWER]	12
	Press to switch the unit from on to standby mode or vice versa. In standby mode, the unit is still consuming a small amount of power.	
	Standby/on indicator [⏻/I] When the unit is connected to the AC mains supply, this indicator lights red in standby mode and lights green when the unit is turned on.	
④	Disc indicators [DISC 1–5]	12
④	Wake timer indicator [WAKE]	27
④	Display	
④	Stop, tune mode button [■, TUNE MODE]	12, 22
④	Pause, FM mode button [⏸, FM MODE]	12, 22
④	HT95 Progressive out indicator [PROGRESSIVE OUT]	12
④	HT95 Progressive out button [PROGRESSIVE OUT]	12
④	HT75 Sound field control button [SFC]	25
④	Volume control [VOLUME, DOWN, UP]	12, 22
④	Disc tray	12
④	Open/close button [▲ OPEN/CLOSE]	12
④	Play, memory button [▶, MEMORY]	12, 23
④	Skip/search, tuning buttons [◀◀/▶▶, ▼ TUNING ▲]	13, 22
④	Headphone jack [PHONES]	27
④	Remote control signal sensor	
④	Input select button [SELECTOR]	12

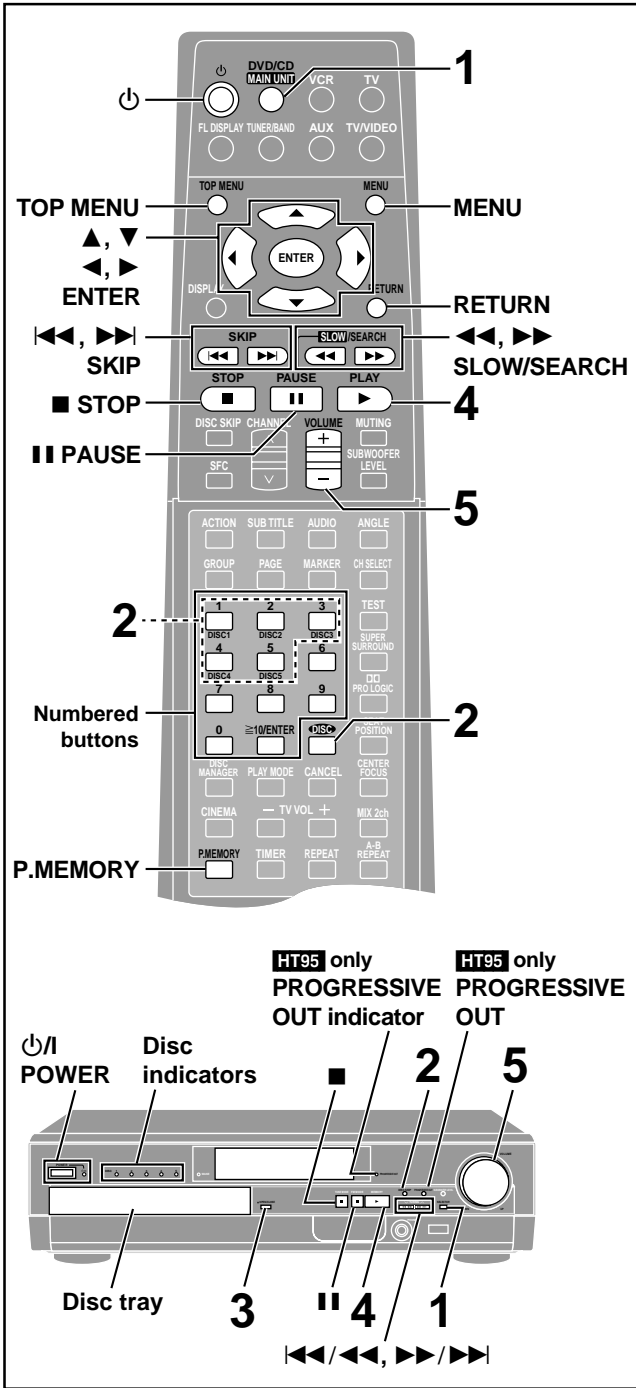

DVD-A DVD-V CD VCD

Preparation

- Turn on the television and select the appropriate video input on the television to suit the connections for the player.
- Press [POWER] to turn on the unit.

1 Press [SELECTOR] to select “DVD/CD”.

Each time you press the button:
DVD/CD → FM → AM → TV → VCR → AUX

Remote control: Press [DVD/CD].

HT95
For progressive output:
 Press [PROGRESSIVE OUT] so the indicator lights.

NOTE
 This unit does not output video signals from the VIDEO OUT and S-VIDEO OUT terminals when the “PROGRESSIVE OUT” indicator is on.

2 Press [DISC SKIP] to select a tray.

The indicator lights.
 Play starts if a disc is in the tray. (One touch play)

Remote control:
 Press [DISC] and then press [1]–[5] corresponding to the required tray.

3 Press [▲] to open the disc tray and insert a disc.

Press again to close and start play.

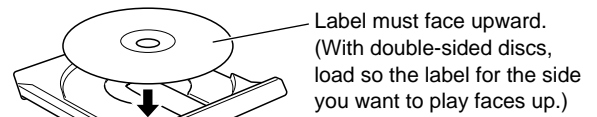

Repeat steps 2 and 3 to insert other discs.

4 If play doesn't start after step 3

Press [▶] (PLAY).

Lights during play.

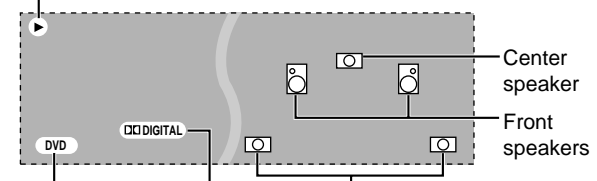

5 Adjust the volume.

■ To stop play

Press [■] (→ page 13, Resume function).

■ To pause play

Press [⏸] during play.
 Press [▶] (PLAY) to restart play.

Note

- If “⊘” appears on the television
 The operation is prohibited by the unit or disc.
- The disc continues to rotate while the menu is displayed even after you finish playing an item. Press [■] when you finish to preserve the unit's motor and your television screen.
- Volume may be lower when playing DVDs than when playing other discs or during television broadcasts.
 If you turn the volume up, be sure to reduce the volume again before playing other sources so that a sudden increase in output does not occur.

When a menu appears on the television

DVD-A DVD-V VCD

Remote control only

Press the numbered buttons to select an item.

To select a 2-digit number

Example: To select item 23, press [≧10/ENTER] → [2] → [3].

- When playing DVDs, you can also use [▲], [▼], [◀], [▶] to select items. Press [ENTER] to confirm your selection.

Play of the selected item now begins.

Other buttons used to operate menus

Read the disc's instructions for further details about operation.

[▶▶]: Shows the next menu.

[◀◀]: Shows the previous menu.

[RETURN]: Shows the menu screen. **VCD**

[TOP MENU]: Shows the first menu screen. **DVD-A DVD-V**

[MENU]: Shows the menu screen. **DVD-V**

Playing MP3

CD

Discs recorded using MP3 differ to CDs in the following ways.

•Structure of the disc (example)

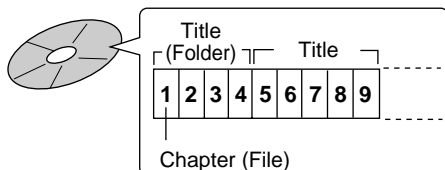

•Starting play from a selected chapter

Press the numbered buttons and press [ENTER].

Example: Chapter 23: [2] → [3] → [ENTER]

(Pressing [≥10/ENTER] is unnecessary.)

•Repeat play

You can use chapter repeat or title repeat.

•Program play, random play and disc manager

You cannot use program play, random play or disc manager.

Note

- If you play an MP3 track that includes still picture data, it will take some time before the music itself starts playing and the elapsed time will not be displayed during this time. Even after the track starts, the correct play time will not be displayed.
- This unit is not compatible with ID3 tags.
- This unit is not compatible with files with a sampling rate of 32 kHz.

Refer to the glossary on page 36 for more information about MP3.

Resume function

DVD-A DVD-V CD VCD

(When the elapsed play time is displayed)

“RESUME” lights on the display when the unit has recorded the position at which you stopped play.

RESUME

Press [▶] (PLAY) to start play from that position.

(When playing DVD-Video → Chapter Preview below)

- The position is cleared when:
 - The unit is turned off.
 - The disc is changed or removed.
 - A source other than DVD/CD is selected.
- Press [■] to clear the position.

Position Memory function DVD-V CD VCD

During play

Press [P.MEMORY] to memorize a position.

The message “Position memorized” appears on the television.

This position is saved if you turn the unit off or change the source.

When you turn the unit on or reselect DVD/CD, “RESUME” lights on the display.

Press [▶] (PLAY) to start play from the memorized position.

The position is cleared.

(When playing DVD-Video → Chapter Preview below)

Chapter Preview DVD-V

The message “Press PLAY to Preview Chapters” appears immediately after you press [▶] (PLAY).

Press [▶] (PLAY) while the message is displayed and the beginning portions of each chapter up to the current one are played.

Full play resumes from the point where you pressed [■] or [P.MEMORY].

(This feature works only within a title.)

If you do not press [▶] (PLAY), the message disappears and play starts from where you pressed [■] or [P.MEMORY].

Skipping chapters or tracks

DVD-A DVD-V CD VCD

Press [◀◀] or [▶▶].

- Each press increases the number of skips.
- Press [◀◀/▶▶, ▶▶/▶▶] on the main unit.

Fast forward and rewind—SEARCH

DVD-A DVD-V CD VCD

During play

Press [◀◀] or [▶▶].

- Press and hold [◀◀/▶▶, ▶▶/▶▶] on the main unit.

- Audio will be heard during the first forward search speed. You can turn this audio off if you want to (→ page 28, Audio—Audio during Search).

Slow-motion play

DVD-A DVD-V VCD

While paused

Press [◀◀] or [▶▶].

- Press and hold [◀◀/▶▶, ▶▶/▶▶] on the main unit.

Frame-by-frame viewing

DVD-A DVD-V VCD

Remote control only

While paused

Press [◀] or [▶].

The frame changes each time you press the button.

- The frames change in succession if you press and hold the button.
- Pressing [■] also activates forward frame-by-frame.

Notes

- The speed of search and slow-motion increases up to 5 steps.
- Press [▶] (PLAY) to restart play.
- You cannot move backwards with Video CD during frame-by-frame and slow-motion.
- Frame-by-frame and slow-motion only work on the moving picture parts of DVD-Audio.

When playing Video CDs with playback control

Pressing buttons to perform skip, search or slow-motion may take you to a menu screen.

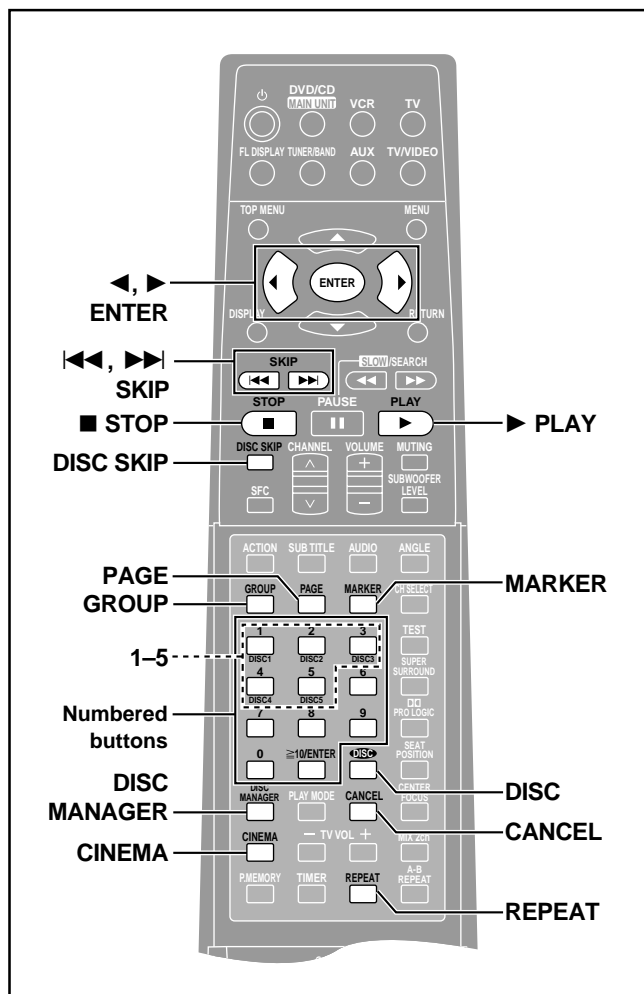

Starting play from a selected track

CD VCD

Remote control only

- 1 Press [DISC].
- 2 Press [1]–[5] to select a disc.
- 3 Wait for the disc to change and play to start
Press the numbered buttons to select the track.
To select a 2-digit number
Example: To select track 23, press [≥ 10 /ENTER] \Rightarrow [2] \Rightarrow [3].

Play starts from the selected item.

Note

This works only when stopped with some discs.

Disc skip

DVD-A DVD-V CD VCD

Press [DISC SKIP].

Play starts from the beginning of the disc in the next tray.
You will skip to tray 1 when the current tray is 5.

Note

[DISC SKIP] does not work during program and random play or while the disc manager is on.

Cinema

DVD-A DVD-V VCD

Remote control only

You can change the picture quality for movie viewing.

Press [CINEMA].

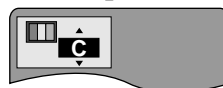

Each time you press the button:

C: Mellows images and enhances detail in dark scenes.



N: Normal mode (Factory preset)

For your reference

You can make finer adjustments to the picture if desired (\Rightarrow page 21, Digital picture mode—User mode).

Marking places to play again— MARKER

DVD-A DVD-V CD VCD

(When the elapsed play time is displayed)

Remote control only

You can mark up to 5 points on a disc to return to later.

- 1 During play
Press [MARKER].



- 2 Press [ENTER] at the point you want to mark.

To select another marker, press [\leftarrow , \rightarrow].

To play from a marked position

Press [\leftarrow , \rightarrow] to select a marker number and press [ENTER].

To clear a marker

Press [\leftarrow , \rightarrow] to select a marker number and press [CANCEL].

Note

- Some subtitles may fail to appear around the marker.
- All the markers are cleared when:
 - The unit is turned off.
 - The disc is changed or removed.
 - A source other than DVD/CD is selected.

Using the disc manager

CD VCD

Remote control only

The disc manager allows you to choose one track or disc to play or to play all five discs in succession.

- 1 **While stopped**
Press [DISC MANAGER] to select the desired method.

Each time you press the button:

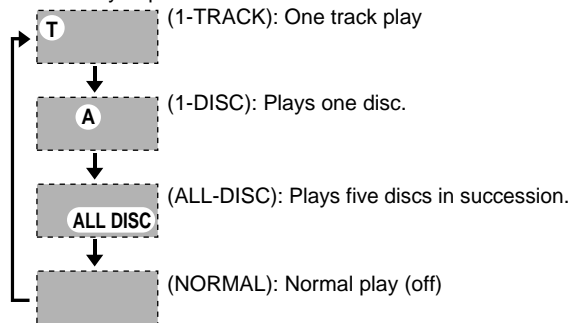

- 2 **Select the disc and track.**

- When selecting “1-DISC”, press [DISC] and [1]–[5].
- When selecting “1-TRACK”, press the numbered buttons.
To select a 2-digit number
Example: To select track 23: press [≥ 10 /ENTER] \Rightarrow [2] \Rightarrow [3].
You can also select the track by pressing [◀◀] and [▶▶].

- 3 **Press [▶] (PLAY).**

To cancel disc manager

Press [■].

To play a track or disc repeatedly

Press [REPEAT] during disc manager play.

Note

- You cannot use the disc manager while “RANDOM” or “PRGM” are on.
- When playing video CDs with playback control in the “A” or “ALL DISC” mode, you can play the disc without having to operate the disc’s menus.
- The disc manager skips any DVD and MP3 discs that are loaded.

Selecting groups to play

DVD-A

Remote control only

The tracks on DVD-Audio are divided into groups. How these groups are played differs with the disc so read the instructions that came with the disc for further details.

- 1 **Press [GROUP].**

The group number changes each time you press the button.



- 2 **Press [ENTER].**
- 3 **Press the numbered buttons to select the track number and press [ENTER].**
The selected group and track begin to play.

Playing all the groups in succession (\Rightarrow page 17, All group play)

Playing bonus groups

Some discs contain bonus groups. To enjoy these groups you may have to enter a password. Refer to the disc’s jacket.

1. Press [GROUP] to select the bonus group and press [ENTER].
2. Enter the 4-digit password with the numbered buttons and press [ENTER].
 - If you enter the wrong password, you can erase a digit by pressing [CANCEL].
3. Press the numbered buttons to select a track and press [ENTER].

- The password is cleared when:
 - The unit is turned off.
 - The disc is changed or removed.
 - A source other than DVD/CD is selected.

Selecting still pictures—Page Skip

DVD-A

Remote control only

During play

- Press [PAGE].

The page changes each time you press the button.

PAGE 1

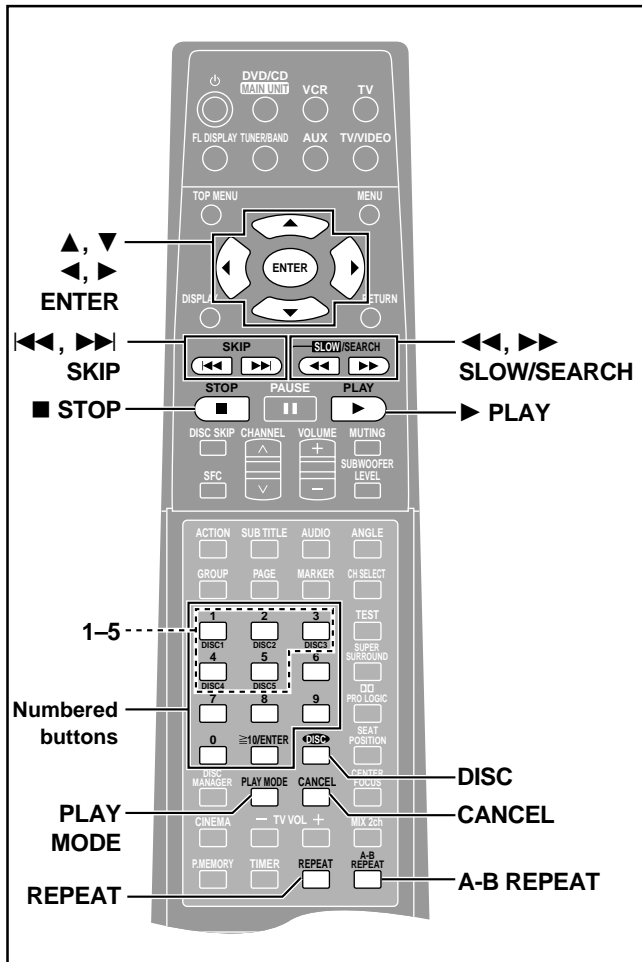

DVD-A DVD-V (When the elapsed play time is displayed)
CD VCD

Remote control only

A-B repeat play

You can repeat a section between points A and B within a title or track.

- 1 During play
 Press **[A-B REPEAT]** at the starting point (A).



- 2 Press **[A-B REPEAT]** at the finishing point (B).

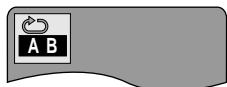

A-B repeat starts.

To cancel

Press **[A-B REPEAT]** until “” is displayed.

Note

- Some subtitles recorded around point A or B may fail to appear.
- The unit automatically determines the end of a title/track as point B when the end of the title/track is reached.

Repeat play

During play

Press **[REPEAT]**.

Each time you press the button:

DVD-A

Track → Whole group → OFF

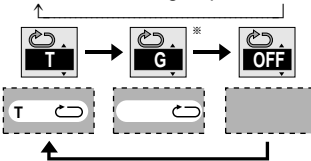

* During All group, Program, or Random play mode, “A” is displayed instead of “G”.

DVD-V CD (MP3 disc)

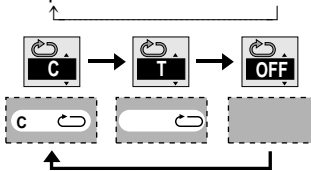

Chapter → Title → OFF



CD VCD

Repeat on ↔ OFF

You can repeat tracks as follows depending on the DISC MANAGER setting (⇒ page 15).

Normal or 1-DISC	1-TRACK	ALL-DISC
		

If the Video CD has playback control

1. Press **[■]**.
2. Press the numbered buttons to select a track to start play (⇒ page 14).
3. Press **[REPEAT]** (⇒ above).

Note

You cannot use repeat play to repeat an entire DVD-Video or an entire MP3 disc.

To repeat only your favorite tracks

DVD-A CD VCD

Start program play (⇒ page 17) and press **[REPEAT]** to display the repeat mode you like.

All group play/Program play/Random play/All disc random play

DVD-A

CD VCD (There is no on-screen display.)

Remote control only

While stopped

Press **[PLAY MODE]** to select the play mode.

The mode changes as follows each time you press the button.



After selecting the mode, follow the steps for the mode.

DVD-A If you select bonus groups, you will have to enter a 4-digit password (→ page 15).

All group play **DVD-A**

To play all the groups in succession

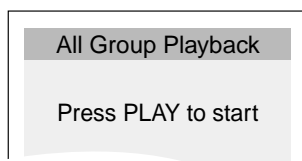

Press **[▶]** (PLAY).

Random play

To play tracks on the current disc randomly

e.g. **DVD-A** (three groups)

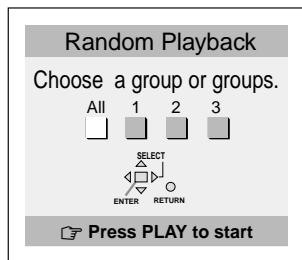

1 DVD-A

Press **[◀, ▶]** to select a group and press **[ENTER]**.

• You can select more than one group.

2 Press [▶] (PLAY).

Play now begins in random order.

To clear a group **DVD-A**

Press **[◀, ▶]** to select the group you want to clear, then press **[ENTER]**.

All disc random play **CD VCD**

To play tracks on all discs randomly

Press **[▶]** (PLAY).

Play now begins in random order.

• DVD and MP3 discs are skipped during all disc random play.

Program play

To play a maximum of 24 tracks in a programmed order

DVD-A Select tracks from the disc in the play position.

CD VCD Select tracks from any disc.

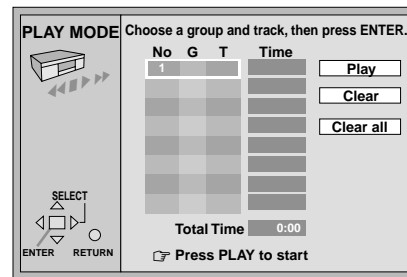

e.g. **DVD-A**

1

DVD-A

Press the numbered buttons to select a group.

CD VCD

Press **[DISC]** and **[1]–[5]** to select the disc.

2

Press the numbered buttons to select a track.

• Repeat steps 1 and 2 to program other tracks.

• **CD VCD**

Step 1 is unnecessary when programming tracks on the same disc.

• **DVD-A** To select a track using the cursor buttons

Press **[ENTER]** and **[▲, ▼]** to select a group or track, then press **[ENTER]** again to register the number.

All the tracks in the selected group are selected when you select "ALL".

3

Press **[▶]** (PLAY).

Play now begins in the programmed sequence.

When play is stopped and the program contents are shown on the display, you can also do the following.

• To add tracks

Repeat steps 1 and 2.

• To check program contents

Press **[◀◀]** or **[▶▶]**.

• To clear tracks

Press **[CANCEL]** to clear the last track in the program, or press **[◀◀]** or **[▶▶]** to select a track and press **[CANCEL]**.

• To clear the whole program

Press **[■]** so "CLEAR" is displayed. (If "CLEAR" is not displayed, start and stop play, then press **[■]** again.)

DVD-A (Follow the on-screen instructions.)

To add or change groups or tracks

Press **[▲, ▼]** to select an available item, then repeat steps 1 and 2.

To move to the page before or after the one shown

Press **[◀◀]** or **[▶▶]**.

To clear a track

1. Select the item you want to clear.

2. Select "Clear" with **[▲, ▼, ◀, ▶]** and press **[ENTER]**.

To clear the whole program

Select "Clear all" with **[▲, ▼, ◀, ▶]** and press **[ENTER]**.

Note

Groups, discs or tracks the unit cannot find can be programmed but are canceled during play. This is also the case if you program DVD-Audio, DVD-Video and MP3 discs.

Normal play

The play mode is canceled (normal play mode is restored) when:

–The unit is turned off.

–The disc is changed or removed.

–A source other than DVD/CD is selected.

CD VCD

The program is retained in memory.

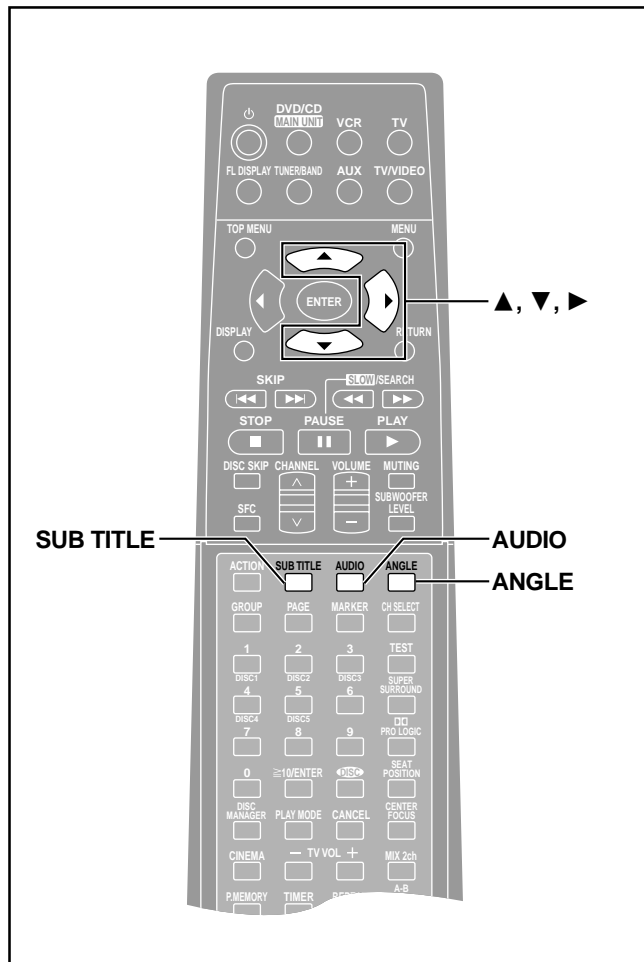

Subtitles

During play

Press [SUB TITLE].

The number changes each time you press the button.

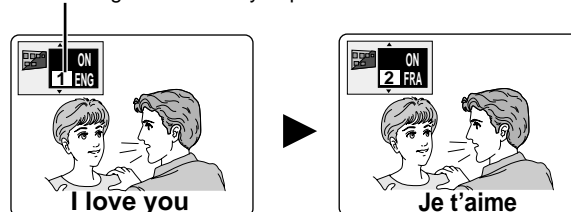

- In some cases, the subtitle language is not changed to the selected one immediately.
- If the subtitles overlap closed captions recorded on discs, turn the subtitles off.
- Refer to **A** on page 20 for language abbreviations.

To clear/display the subtitles

1. Press [SUB TITLE].
2. Press [▶].
3. Press [▲, ▼] to select "OFF" or "ON".

Angles

"ANGLE" lights on the unit's display when this is available.

During play

Press [ANGLE].

The number changes each time you press the button.

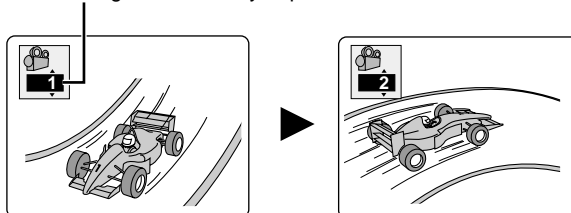

DVD-A DVD-V

Remote control only

Some DVDs have multiple soundtracks, subtitle languages and camera angles, and you can change these during play.

- "—" or "--" is displayed instead of the language number in circumstances such as when no language is recorded on the disc.

Soundtracks

During play

Press [AUDIO].

The number changes each time you press the button.

DVD-Audio

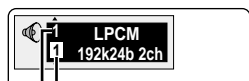

Soundtrack selected
Soundtrack playing

DVD-Video

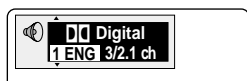

- Play restarts from the beginning of the soundtrack when changing DVD-Audio soundtracks that are accompanied by still pictures.
- Even if a second soundtrack isn't recorded on a DVD-Audio, two soundtrack numbers will normally be shown when you press [AUDIO]. The soundtrack currently playing is number 1.
- You can also use this button to turn the vocals on and off on karaoke discs. Read the disc's instructions for details.
- Refer to **A** and **B** on page 20 for language abbreviations and audio signal type details.

VCD

Audio changes as follows each time you press [AUDIO]:

LR → L → R
↑

This may not work with some discs.

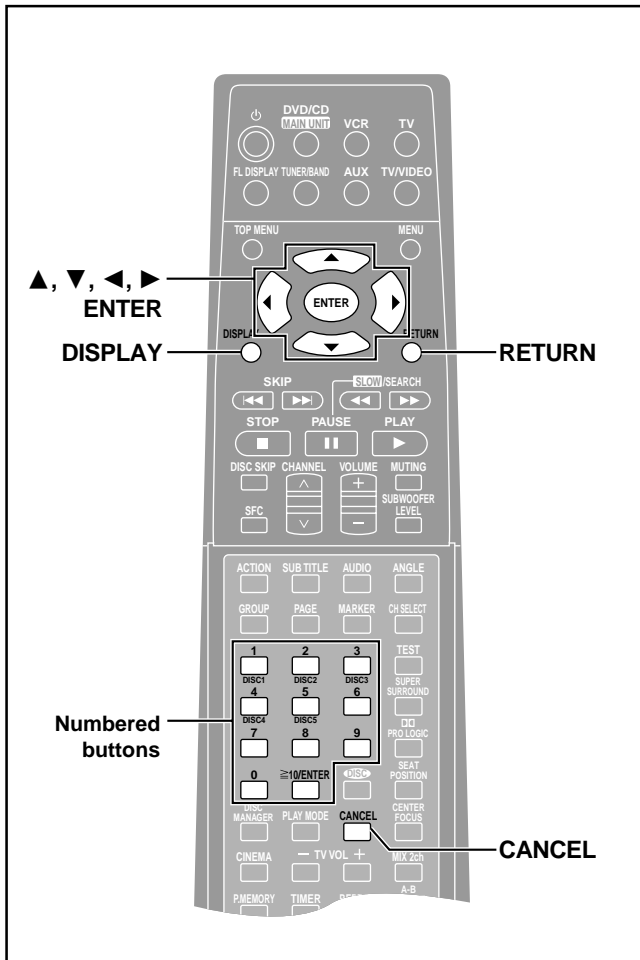

DVD-A DVD-V

Remote control only

On-Screen Menu Icons are menus that contain information about the disc or unit. These menus allow you to perform operations by changing this information.

Common procedures

1 Press [DISPLAY].

Each time you press the button:

e.g. DVD-Video

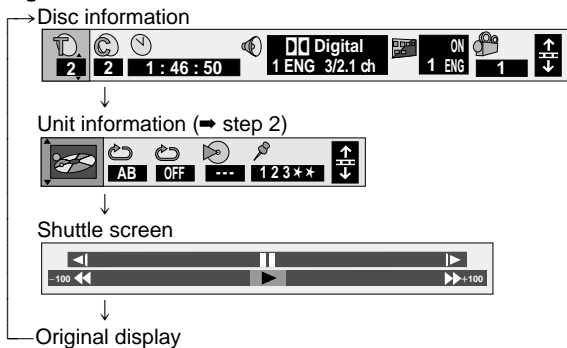

• The screens depend on disc contents.

2 Unit information only

While the leftmost icon is highlighted

Press [▲, ▼] to select the menu.

Each time you press the button:

e.g. DVD-Video

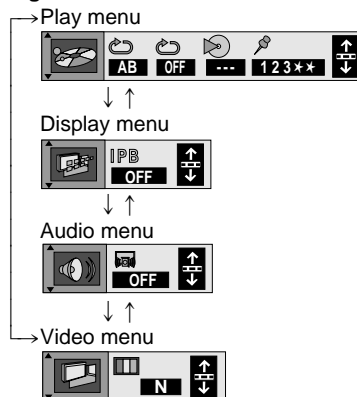

3 Press [◀, ▶] to select the item.

4 Press [▲, ▼] to select the setting.

- Items with “▲” or “▼” above and below can be changed by [▲, ▼].
- Press [ENTER] if the setting does not change after pressing [▲, ▼].
- Some items require different operations. Read the explanations on the following pages.

For your reference

- Depending on the condition of the unit (playing, stopped, etc.) and the type of software you are playing, there are some items that you cannot select or change.
- When numbers are displayed (e.g. title No.), the numbered buttons are also effective for setting. After entering the numbers, press [ENTER] to register the setting.

To clear the menus

Press [RETURN] until the menus disappear.

■ To change the position of the menus

1. Press [◀, ▶] to select the rightmost icon.
2. Press [▲, ▼] to move the menus.



(There are 5 positions.)

Disc information

e.g. DVD-Video



Icon	Content
	DVD-A Group number
	DVD-A Track number DVD-V Title number
	DVD-V Chapter number
	Time Select a position to start play by specifying a time with the numbered buttons. DVD-A Changing the time display Press [▲, ▼] to show the elapsed play time, remaining time for the track, or remaining time for the group.
	Soundtrack a) Soundtrack language (See A at right for language abbreviations.) b) Audio signal type (See B at right for details.)
	Karaoke vocal on/off (Karaoke DVD only) Solo: OFF or ON Duet: OFF, V1+V2, V1 or V2

Icon	Content
	Subtitle language (See A below for language abbreviations.)
	Subtitles on/off ON ↔ OFF
	Angle number
	DVD-A Still picture number Selected picture is shown during play.

A Audio/Subtitle language

ENG: English	SVE: Swedish	CHI: Chinese
FRA: French	NOR: Norwegian	KOR: Korean
DEU: German	DAN: Danish	MAL: Malay
ITA: Italian	POR: Portuguese	VIE: Vietnamese
ESP: Spanish	RUS: Russian	THA: Thai
NLD: Dutch	JPN: Japanese	*: Others

B Signal type/data

LPCM/PPCM/Digital/DTS: Signal type

k (kHz): Sampling frequency

b (bit): Number of bits

ch (channel): Number of channels

Example:

3/2 .1ch

.1: Subwoofer signal
(not displayed if there is no subwoofer signal)

0: No surround
1: Mono surround
2: Stereo surround (left/right)

1: Center
2: Front left+Front right
3: Front left+Front right+Center

Unit information

Play menu

Icon	Content
	A-B repeat (⇒ page 16) [ENTER] (start point) ⇒ [ENTER] (finish point) To cancel: [ENTER]
	Repeat play (⇒ page 16) DVD-A Track (T) ↔ Whole group (G) ↔ OFF During All group, Program, or Random play mode, "A" is displayed instead of "G". DVD-V Chapter (C) ↔ Title (T) ↔ OFF

Icon	Content
	DVD-A Play mode display ---: Normal play RND: Random play PGM: Program play ALL: All group play
	Marker (⇒ page 14) You can mark up to 5 positions to play again. [ENTER] (The unit is now ready to accept markers.) To mark a position [ENTER] (at the desired point) To mark another position: [◀, ▶] ⇒ [ENTER] To recall a marker: [◀, ▶] ⇒ [ENTER] To erase a marker: [◀, ▶] ⇒ [CANCEL]



 **Display menu**

Icon	Content
	I/P/B display (⇒ page 36) ON↔OFF Displays the picture type (I/P/B) in the still picture mode.

 **Audio menu**

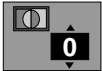

Icon	Content
	(Dolby Digital/DTS, 3-channel or over only) DVD-V Dialogue Enhancer ON↔OFF The volume of the dialogue from the center channel is raised when you select "ON".

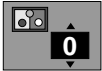
 **Video menu**

Icon	Content
	Digital picture mode N: Normal mode C: Cinema mode (⇒ page 14) U: User mode The following items are also displayed when you select "U".
	Contrast (-7 to +7) Increases the contrast between white and black parts of the picture.
	Brightness (0 to +15) Brightens the picture.
	Color (-7 to +7) Adjust the shade of the picture's color.

HT95





When the progressive indicator is on (⇒ page 12):

Icon	Content
	Digital picture mode N: Normal mode C: Cinema mode (⇒ page 14)
	Transfer MODE Select the method of conversion for progressive output to suit the type of material being played (⇒ page 36, "Film and video"). Auto (normal): for viewing film material Video: for video material
	Horizontal position Press the numbered buttons to change the horizontal position of the picture. After highlighting the icon shown at left: 1. Press [1]. 2. Press [1] to move the picture to the left or [3] to move the picture to the right. • Pressing [2] returns the position to the factory preset. This position is saved even if you turn the unit off.

Shuttle screen

There are five speeds for both backward and forward slow-motion and search.

The numbers on either side of the shuttle screen indicate the maximum speeds of the search.

Icon	Content
	Pause
	Slow-motion play ◀: Backward ▶: Forward
	Play
	Search ◀◀: Backward ▶▶: Forward

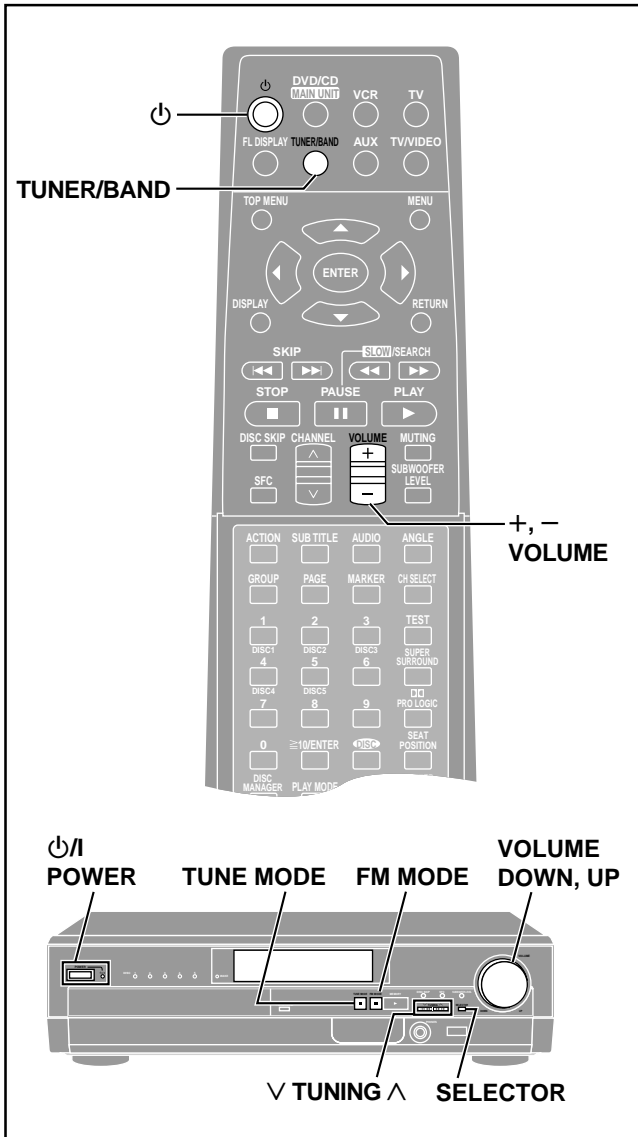

Radio stations can be tuned manually by selecting the station's frequency or they can be preset into channels to make it easy to tune (➔ page 23).

Unless otherwise indicated, frequency display examples shown are for the model for the U.S.A., Canada, and units with PX printed on the outer packaging.

Preparation

Press [POWER] to turn on the unit.

1 Press [SELECTOR] to select "FM" or "AM".

Each time you press the button:

DVD/CD → FM → AM → TV → VCR → AUX

• Remote control: Press [TUNER/BAND].



2 Press [TUNE MODE] to select "MANUAL".

Each time you press the button:

MANUAL ↔ PRESET



3 Press [TUNING (V or ^)] to select the frequency of the required station.

Displayed when a stereo FM broadcast is being received.



Displayed when a radio station is tuned.

Press and hold [TUNING (V or ^)] until the frequency starts scrolling to start automatic tuning. Tuning stops when a station is found.

4 Adjust the volume.

If noise is excessive in FM

Main unit only

Press [FM MODE] to display "MONO".



This mode improves sound quality if reception is weak but broadcasts are heard in monaural.

Press [FM MODE] again to cancel the mode.

The mode is also canceled when you changed the frequency.

Turn "MONO" off for normal listening.

Stereo and monaural broadcasts are automatically played as they are received.

Allocation settings

Main unit only

Each country allocates broadcast bands according to their particular system.

For U.S.A., Canada, and units with PX printed on the outer packaging

You can change the FM step. The step is factory-set to 0.2 MHz, but you can change it to receive broadcasts allocated 0.1-MHz steps.

For Latin America

You can change the AM step. The step is factory-set to 9 kHz, but you can change it to receive broadcasts allocated 10-kHz steps.

① Press [SELECTOR] to select "FM" (for either band).

② Press and hold [SELECTOR].

After a few seconds, the current minimum frequency flashes on the display. Continue to hold the button down. The minimum frequency changes and the step is changed.

To return to the original step, repeat the above steps.

Note

Preset in channels (FM and AM) will be changed by this procedure. Preset them again.

The radio: preset tuning

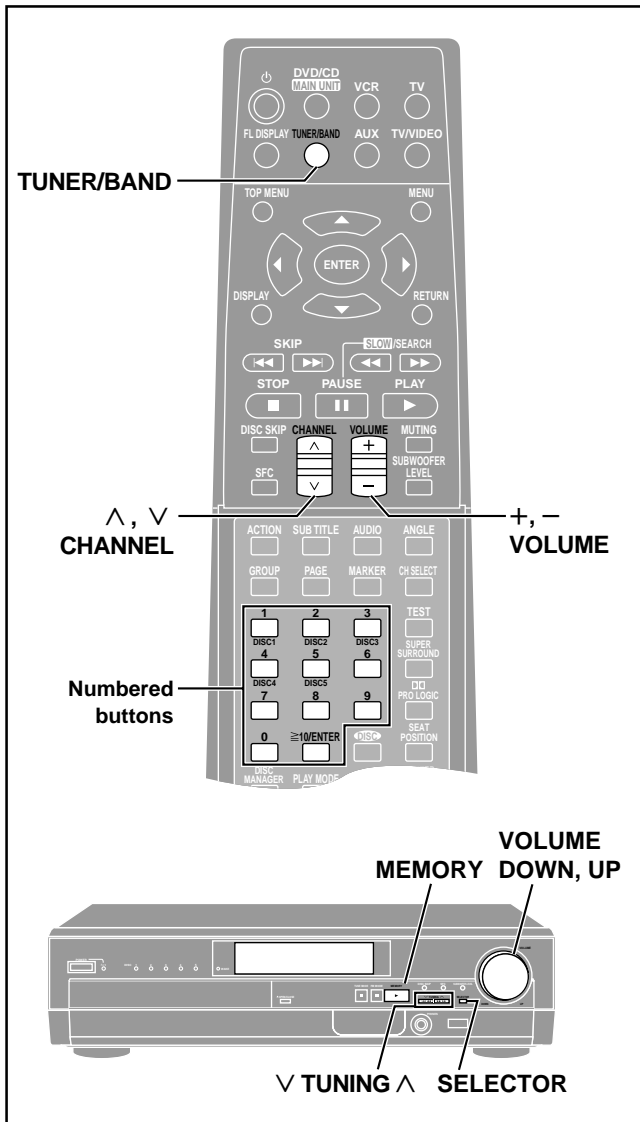

There are two methods of presetting stations.
Automatic presetting: The stations the tuner can receive are preset.
Manual presetting: You can select the stations to preset and the order they are preset in.
 Up to 12 stations can each be set in the FM and AM bands.

Automatic presetting

Main unit only

For U.S.A., Canada, and units with PX printed on the outer packaging

- 1 Tune to “FM 87.9 MHz” (or “FM 87.5 MHz”) (⇒ page 22).
- 2 Press and hold [MEMORY].
The FM stations the unit can receive are preset.
- 3 Tune to “AM 520 kHz” (⇒ page 22).
- 4 Press and hold [MEMORY].
The AM stations the unit can receive are preset.



The last station to be preset is displayed when presetting finishes.

For Latin America

- 1 Tune to “FM 87.50 MHz” (⇒ page 22).
- 2 Press and hold [MEMORY].
The FM stations the unit can receive are preset.
- 3 Tune to “AM 522 kHz” (or “AM 520 kHz”) (⇒ page 22).
- 4 Press and hold [MEMORY].
The AM stations the unit can receive are preset.



The last station to be preset is displayed when presetting finishes.

Manual presetting

Main unit only

Preset the stations one at a time.

- 1 Tune to the station (⇒ page 22).
- 2 Press [MEMORY] twice.
- 3 Press [TUNING (∨ or ∧)] to select a channel.
- 4 Press [MEMORY].

The station occupying a channel is erased if another station is preset in that channel.

Selecting channels

- 1 Press [TUNER/BAND] to select “FM” or “AM”.

•Main unit: Press [SELECTOR].
 Each time you press the button:
 DVD/CD → FM → AM → TV → VCR → AUX



- 2 Press the numbered buttons or [CHANNEL (∧ or ∨)] to select the channel.

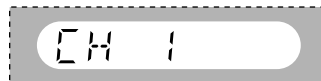

To select a 2-digit number
 Example: To select channel 12, press [≥10/ENTER] → [1] → [2].
 •Main unit: Press [TUNING (∨ or ∧)] while “PRESET” is selected.



- 3 Adjust the volume.

Note

- Dolby Pro Logic and Super Surround cannot be used if headphones are connected.
- You may experience a reduction in sound quality when these sound field systems and effects are used with some sources. If this occurs, turn the sound field system or effect off.

Sound field system	Features	Software	Other effects									
DOLBY DIGITAL and DTS (→ page 25)	<ul style="list-style-type: none"> •Dolby Digital and DTS are digital encoding systems used on DVD to carry surround sound. Both were originally developed for use in cinemas. •This unit automatically recognizes and decodes these systems. 	Software encoded with Dolby Digital can be identified with this mark.  Software encoded with DTS can be identified with this mark.  •DVD	Seat position Center focus									
DOLBY PRO LOGIC (→ page 25)	Dolby Pro Logic is a decoding system that was developed to get a better sense of presence from sources encoded with Dolby Surround. The feeling of position has been improved by the addition of a separate center speaker channel.	Software encoded with Dolby Surround can be identified with this mark.  •DVD •CD, Video CD •Laser Disc •Video tape	Seat position Center focus									
<table border="1"> <tr> <td rowspan="2"> SUPER SURROUND (→ page 26) </td> <td> MUSIC </td> <td> <ul style="list-style-type: none"> •This mode adds surround effects to stereo sources. •You can adjust the volume of the surround speakers to get the best surround effect. </td> <td rowspan="2"> Any stereo sound source. </td> <td> — </td> </tr> <tr> <td> MOVIE </td> <td> <ul style="list-style-type: none"> •This mode adds surround effects to movie software that hasn't been recorded with the above systems. •You can adjust the volume of the surround speakers to get the best surround effect. </td> <td> Seat position </td> </tr> </table>	SUPER SURROUND (→ page 26)	MUSIC	<ul style="list-style-type: none"> •This mode adds surround effects to stereo sources. •You can adjust the volume of the surround speakers to get the best surround effect. 	Any stereo sound source.	—	MOVIE	<ul style="list-style-type: none"> •This mode adds surround effects to movie software that hasn't been recorded with the above systems. •You can adjust the volume of the surround speakers to get the best surround effect. 	Seat position				
SUPER SURROUND (→ page 26)		MUSIC	<ul style="list-style-type: none"> •This mode adds surround effects to stereo sources. •You can adjust the volume of the surround speakers to get the best surround effect. 		Any stereo sound source.	—						
	MOVIE	<ul style="list-style-type: none"> •This mode adds surround effects to movie software that hasn't been recorded with the above systems. •You can adjust the volume of the surround speakers to get the best surround effect. 	Seat position									
SFC (Sound Field Control) (→ page 25)	Use SFC effects to change the sound quality and add reverberation.	Any source.	—									

Seat position (→ page 26)

- This mode helps maintain the sound position even if the listening position itself is changed.

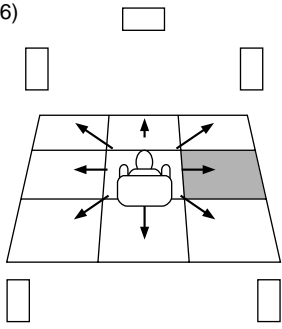

Center focus (→ page 26)

- This mode makes it seem like the sound from the center speaker is coming from within the television.
- You can select one of two levels.
- The center speaker should be placed above the television.

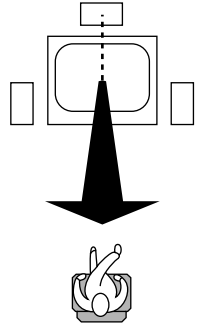

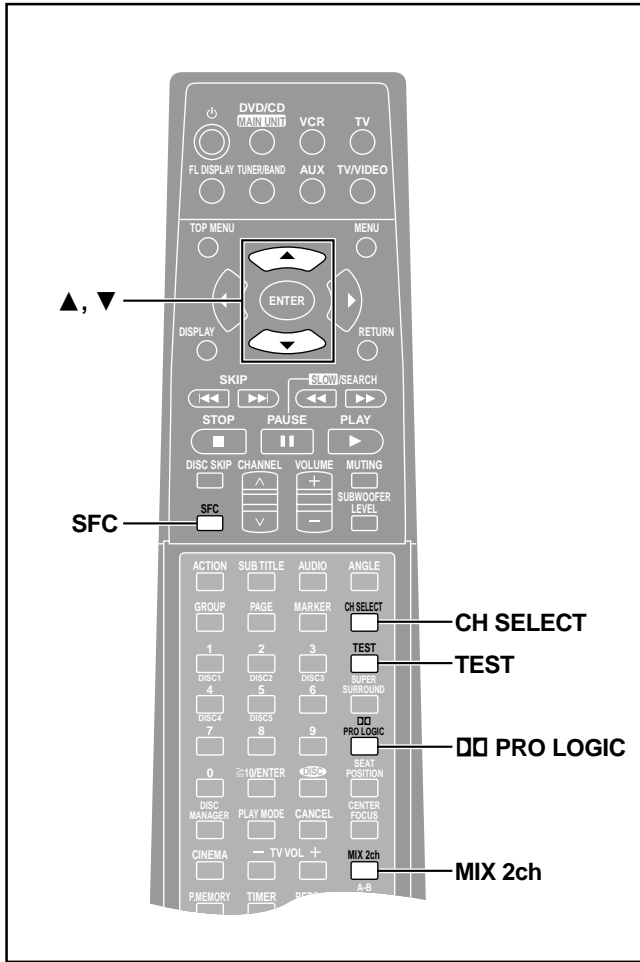

Remote control only

DOLBY DIGITAL and DTS

Play a DOLBY DIGITAL or DTS source.

"DOLBY DIGITAL" or "DTS" lights.



OR

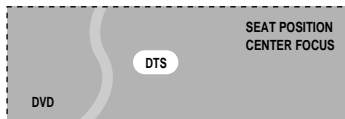

To add power to the bass from the subwoofer ➔ page 26.

To down-mix Dolby Digital or DTS (5.1 ch) signals to 2 channels (Front L/R)

Press [MIX 2ch] during play.

To cancel, press [MIX 2ch] again.



When "MIX2ch" is flashing

The DVD-Audio disc you are playing contains multiple-channel signals that cannot be down-mixed ("NO DOWN-MIX" also appears).

DOLBY PRO LOGIC

1 Press [DOLBY PRO LOGIC].



2 Play a Dolby Surround source.

To cancel

Press [DOLBY PRO LOGIC].

Note

Turn Dolby Pro Logic off when playing a DVD recorded with Dolby Digital or DTS. The surround effects will not be reproduced correctly if this is left on.

Speaker level adjustments

If the level of the speakers appears to be different while listening to a source, adjust the level of the speakers to the same apparent level.

Preparation

DOLBY DIGITAL and DTS: Turn off the other sound field systems.

DOLBY PRO LOGIC: Press [DOLBY PRO LOGIC].

- ① Remove the discs (or select an empty tray).
- ② Press [TEST] to output a test signal.



- Lch: Front left (-16 dB to 0 dB)
- Cch: Center (+6 dB to -10 dB)
- Rch: Front right (-16 dB to 0 dB)
- RSch: Right surround (+6 dB to -10 dB)
- LSch: Left surround (+6 dB to -10 dB)

- The surround channel for Dolby Pro Logic is monaural so the indicator appears as "Sch" instead.

- ③ Press [▲] (to increase) or [▼] (to decrease).
To stop the test signal, press [TEST] again.

To adjust speaker level during play

1. Press [CH SELECT] to select the speaker.
Lch → Cch → Rch → RSch → LSch → SWch

SWch: Subwoofer (+10 dB to -10 dB)

Dolby Pro Logic

- The surround channel is monaural so the indicator appears as "Sch" instead.
- "SWch" does not appear.

2. Press [▲] (to increase) or [▼] (to decrease).

Changing sound field and quality

Press [SFC] to select a setting.



Each time you press the button:

HEAVY: Adds punch to rock (factory preset).

CLEAR: Clarifies higher sounds.

SOFT: For background music.

DISCO: Reverberates sound to make you feel like you were in a disco.

LIVE: Makes vocals more alive.

HALL: Expands sound to make you feel like you were in a hall.

FLAT: Canceled (no effect is added).

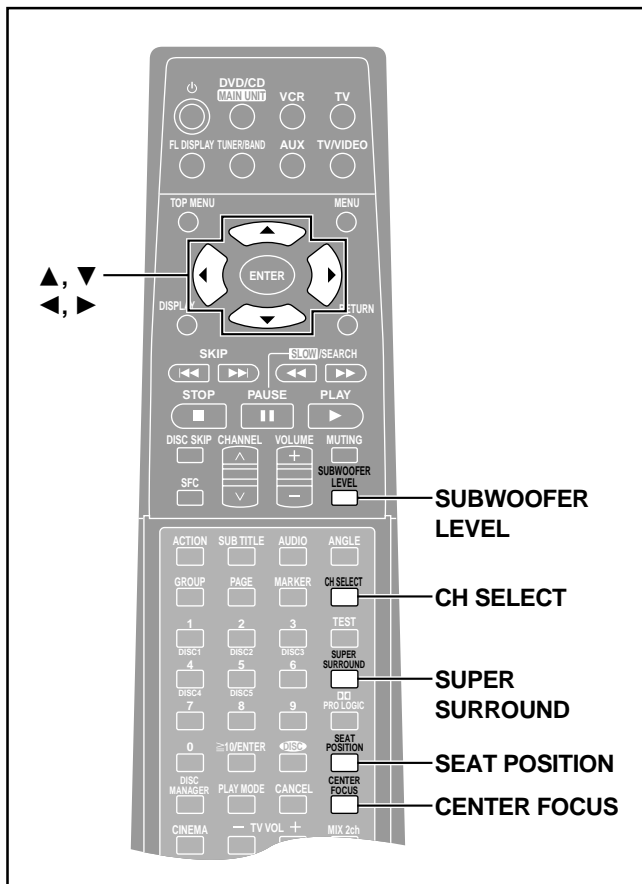

Remote control only

SUPER SURROUND

Press [SUPER SURROUND] to select "MUSIC" or "MOVIE".

Each time you press the button:

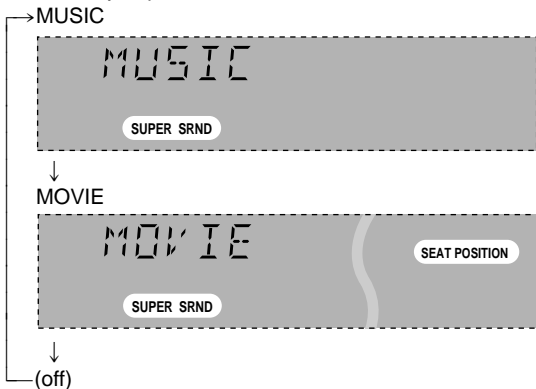

Note

Turn super surround off when playing a DVD recorded with Dolby Digital or DTS. The surround effects will not be reproduced correctly if this is left on.

To adjust the surround speaker level

While playing a source

- ① Press [CH SELECT].
- ② Press [▲] (to increase) or [▼] (to decrease).

SEAT POSITION

Using this function makes you feel like you are sitting in the ideal seating position (in the center of the circle formed by the speakers), even if you cannot due to the layout of your room.

1 Press [SEAT POSITION].

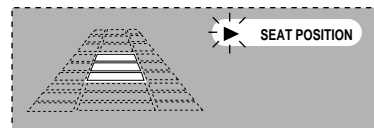

2 While "▶" is flashing Press [▲, ▼, ◀, ▶] to select a position.

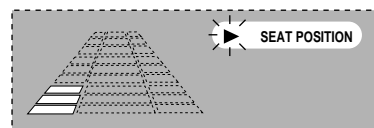

To cancel
Press [SEAT POSITION] to clear "▶".

CENTER FOCUS

You can make the sound of the center speaker seem like it is coming from within the television. Place the center speaker above the television.

Press [CENTER FOCUS].



Each time you press the button:
CENTER FOCUS 1 → CENTER FOCUS 2 → OFF

The CENTER FOCUS 2 enhances the effect and makes it easier to hear dialogue even at low volume.

To cancel
Press [CENTER FOCUS] to clear "▶".

Adjusting the bass

Press [SUBWOOFER LEVEL].

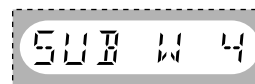

Each time you press the button:
SUB W 1 → SUB W 2 → SUB W 3 → SUB W 4 → SUB W 0 (off)

Note

You cannot adjust the bass while you are using headphones ("ERROR" appears on the display).

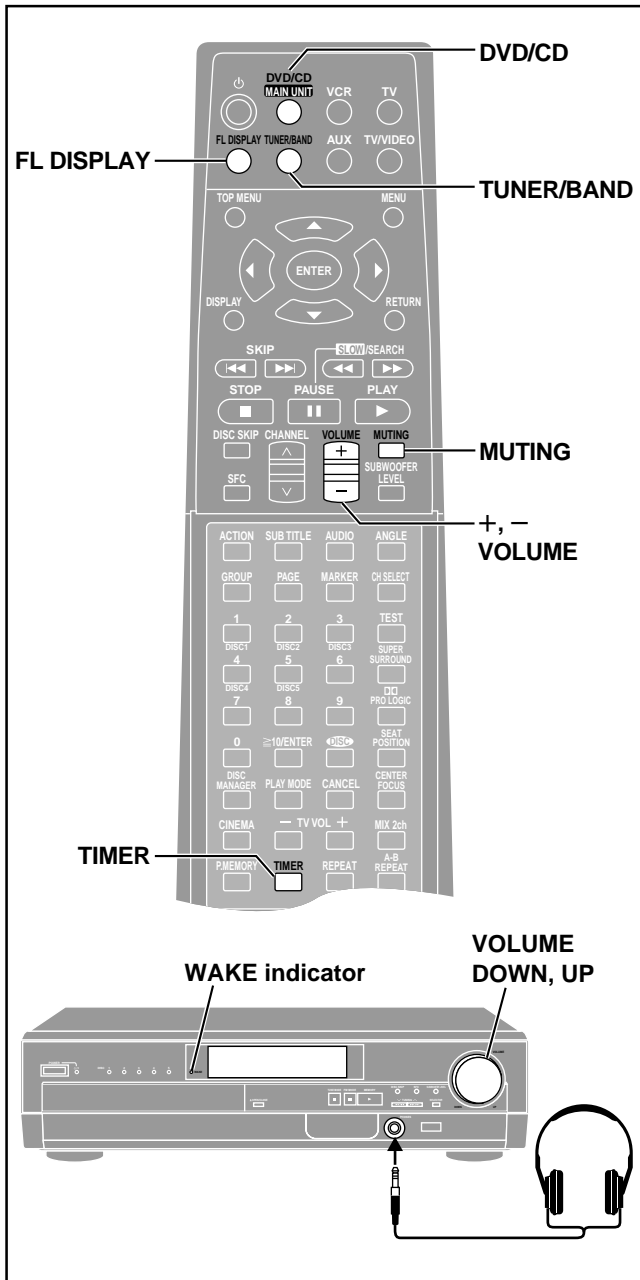

Turning off the display

Remote control only

The display and all indicators, except for the standby/on indicator, are turned off for better television viewing.

Press [FL DISPLAY].

To cancel, press [FL DISPLAY] again.

Timer functions

Remote control only

The SLEEP timer can turn the unit off after a set time and the WAKE timer can turn it on. You can use only one timer at a time.

Preparation

Select the desired source.

•Disc

Press [DVD/CD] to display "DVD/CD", and insert an Audio CD, etc.

•The radio

Press [TUNER/BAND] to select "FM" or "AM" and tune in the desired station.

1 Press [TIMER] to select the timer.

Each time you press the button:

SLEEP → WAKE → OFF

2 Within 5 seconds,

Press and hold [TIMER] and release when the timer you require is displayed.

The display changes as follows:

•SLEEP (in minutes)

30 → 60 → 90

•WAKE (in hours)

5H → 7H → 9H

•SLEEP starts working immediately.

•WAKE starts working when you switch the unit to standby. (The "WAKE" indicator lights up.)

Muting the volume

Remote control only

Press [MUTING].



Volume is reduced to minimum.

To cancel

Press [MUTING] again or reduce the volume to minimum (--- dB), then raise it to the required level.

Muting is also canceled when the unit is turned off.

To cancel the timer

Press [TIMER] to select "OFF".

To check the setting

Press [TIMER] once.

•If you set SLEEP, the time remaining appears.

•If you set WAKE, the setting appears.

To change the setting

Repeat the procedure from the beginning.

Using headphones

1 Reduce the volume and connect the headphones (not included).

Headphone plug type: 6.3 mm (1/4") stereo

2 Adjust headphone volume with [VOLUME].

Audio is automatically switched to stereo (2-channel). If sound is distorted, turn on dynamic range compression (⇒ page 28, Audio—D. Range Compression).





Note

Avoid listening for prolonged periods of time to prevent hearing damage.

Changing settings

This chart shows the settings for this unit. Change the settings to suit your preferences and to suit the unit to the environment in which it is being used. These settings are retained in memory until they are changed, even if the unit is turned off. See page 29 for details on menu operation.

• Underlined items are the factory preset.

Menus	Items	Options
Disc 	Audio <u>DVD-A</u> <u>DVD-V</u> Choose the preferred audio language.	<u>English</u> French Spanish Original Other ***** Original: The original language of each disc will be selected. Other *****: Input a code number with the numbered buttons (⇒ page 36).
	Subtitle <u>DVD-A</u> <u>DVD-V</u> Choose the preferred subtitle language.	<u>Automatic</u> English French Spanish Other ***** Automatic: If the language selected for "Audio" is not available, subtitles of that language will automatically appear if available on that disc.
	Menus <u>DVD-A</u> <u>DVD-V</u> Choose the preferred language for disc menus.	<u>English</u> French Spanish Other *****
	Ratings <u>DVD-V</u> (⇒ page 29) Set a ratings level to limit DVD-Video play. • The password screen is shown if you choose levels 0 to 7 or if you choose "Ratings" when levels 0 to 7 have been selected. • Select "Level 0" to prevent play of discs that do not have ratings levels recorded on them.	Setting ratings (When level 8 is selected) 8 <u>No Limit</u> : All DVD-Video can be played. 1 to 7: Prohibits play of DVD-Video with corresponding ratings recorded on them. 0 <u>Lock All</u> : Prohibits play of all DVD-Video. <hr/> Changing ratings (When level 0–7 is selected) Unlock Player Change Level Change Password Temporary Unlock
Video 	TV Aspect (⇒ page 10) Choose the setting to suit your television and preference.	<u>4:3 Pan&Scan</u> 4:3 Letterbox 16:9
	Still Mode (⇒ page 36) Specify the type of picture shown when paused.	<u>Automatic</u> Field Frame
	Black Level Control Change the black level of the picture.	<u>Lighter</u> Darker <u>HT95</u> Select "Darker" if you connected using the COMPONENT VIDEO OUT terminals.
Audio 	Speaker Setting <u>DVD-V</u> (⇒ page 29) (Dolby Digital only) Set the delay time for your center and surround speakers.	Center: 0/1.3/2.6/3.9/5.3 ms Surround (L/R): 0/5.3/10.6/15.9 ms
	D. Range Compression <u>DVD-V</u> (Dolby Digital only) Change the dynamic range for late night viewing.	<u>Off</u> On Turn dynamic range compression on in the following cases. • For clear dialogue when listening at low volume. • When sound is distorted while playing multi-channel DVD through two channels (when headphones are connected or when using the MIX 2ch mode.)
	Audio during Search <u>DVD-A</u> <u>DVD-V</u> <u>VCD</u> Choose whether to have sound during search.	<u>On</u> Off: Audio will still be heard during search with some DVD-Audio.
Display 	Menu Language Choose the preferred language for these menus and the on-screen messages.	<u>English</u> Français Español
	On-Screen Messages Choose whether to show on-screen messages or not.	<u>On</u> Off
Others 	DVD-Video Mode Select how to play pictures contained on some DVD-Audio. The setting returns to "Off" when: –The unit is turned off. –The disc is changed or removed. –A source other than DVD/CD is selected.	<u>Off</u> :DVD-Audio are played as DVD-Audio. On: DVD-Video contents found on DVD-Audio can be played.

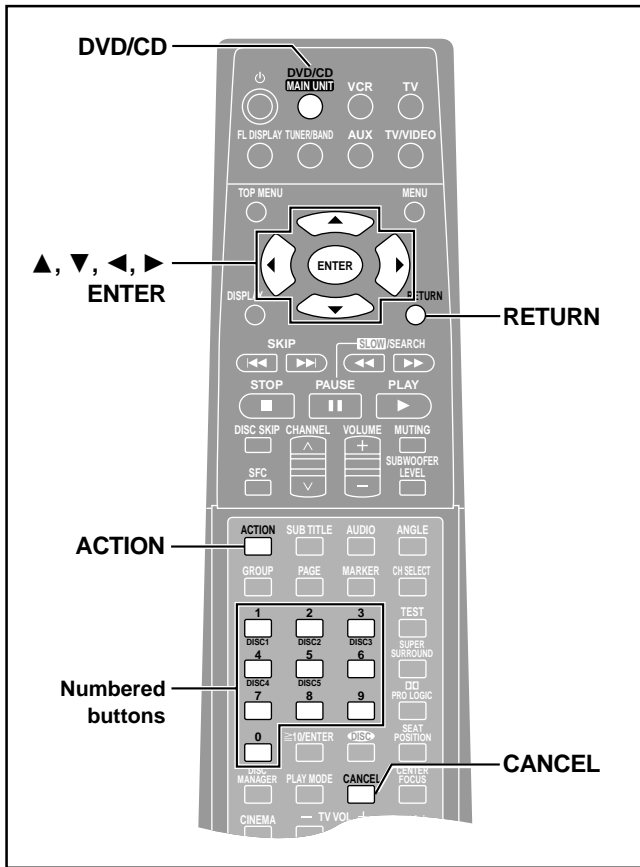

Common procedures

Remote control only

See page 28 for menu and option details.

Preparation

Press [DVD/CD] to select "DVD/CD".

1 Press [ACTION] to show the menus.

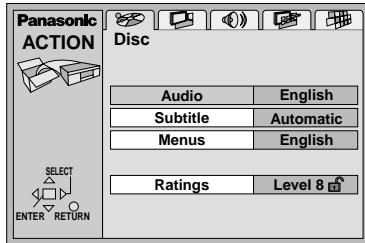

2 Press [◀, ▶] to select the menu's tab.

The screen changes to display the menu.

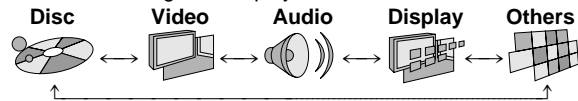

3 Press [▲, ▼] to select the item you want to change and press [ENTER].

4 Press [▲, ▼] to select the option and press [ENTER].

The screen now shows the menu again.

To return to the previous screen

Press [RETURN].

When you are finished

Press [ACTION].

Entering a password (Ratings)

DVD-V

The password screen is shown when you select levels 0 to 7.

- Input a 4-digit password with the numbered buttons and press [ENTER].
 - If you enter a wrong number, press [CANCEL] to erase it before you press [ENTER].
 - The lock symbol appears closed to show the rating is locked.
 - Do not forget your password.**
- Press [ENTER] to confirm the 4 digits.

Now, when you insert a DVD-Video that exceeds the ratings limit you set, a message appears on the television. Follow the on-screen instructions.

Changing the delay time

DVD-V (Dolby Digital, center and surround speakers only)

For optimum listening with 5.1-channel sound, all the speakers, except for the subwoofer, should be the same distance from the seating position. If you have to place the center or surround speakers closer to the seating position, adjust the delay time to make up for the difference.

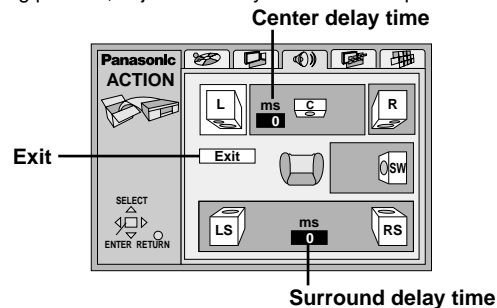

Changing the delay time

- Press [▲, ▼, ▶, ◀] to select the delay time box and press [ENTER].
- Press [▲, ▼] to adjust the delay time and press [ENTER].

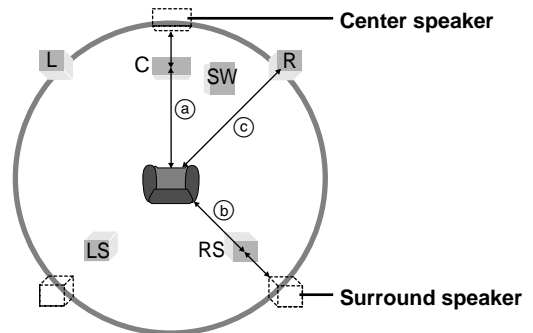

Values

If distance (a) or (b) is greater than or equal to distance (c), set to "0". If distance (a) or (b) is less than distance (c), set as follows.

(a) Center speaker

Difference	Setting
Approx. 50 cm (1½ feet)	1.3 ms
Approx. 100 cm (3 feet)	2.6 ms
Approx. 150 cm (5 feet)	3.9 ms
Approx. 200 cm (6 feet)	5.3 ms

(b) Surround speakers

Difference	Setting
Approx. 200 cm (6 feet)	5.3 ms
Approx. 400 cm (12 feet)	10.6 ms
Approx. 600 cm (18 feet)	15.9 ms

When you are finished

Press [◀] to select "Exit" and press [ENTER].

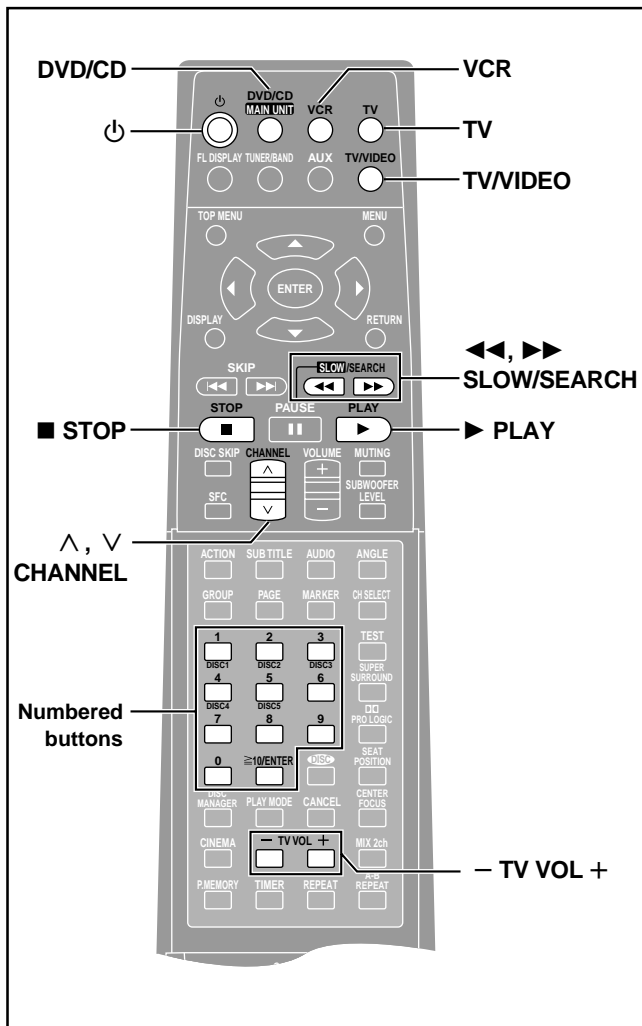

Other functions

Remote control only

Operating a television

Switching to television operation mode

Press [TV].
The button lights.
The main unit also switches to television input.

Turning the television on/off

Press [⏻].

Changing channels

Press [CHANNEL (▲ or ▼)].
You can also select the channel with the numbered buttons.

To select a 2-digit number

Example: To select channel 23, press [≧10/ENTER] → [2] → [3].

Adjusting the volume

Press [TV VOL (- or +)].

Switching the television's video input mode

Press [TV/VIDEO].

Operating a video cassette recorder

Switching to video cassette recorder operation mode

Press [VCR].
The button lights.
The main unit also switches to VCR input.

Turning the video cassette recorder on/off

Press [⏻].

Changing channels

Press [CHANNEL (▲ or ▼)].
Channels 1 to 10 can also be selected with the numbered buttons.
[0] selects channel 10.

Starting play

Press [▶] (PLAY).

Fast-forwarding and rewinding

Press [⏮] or [⏭].

To stop play

Press [■].

Note

- Some models cannot be operated by this remote control.
- To prevent accidental operation, press [DVD/CD] after operation so the unit is ready to operate this unit.

Changing the remote control code

This remote control can operate Panasonic and Technics audiovisual equipment that have remote control sensors. You may need to change the remote control code.

It can also operate some other brands of televisions and video cassette recorders. Check the table for the brand and enter the code as follows.

Aiming the remote control at the television or video cassette recorder, carefully and slowly

While pressing and holding [TV] or [VCR], press the numbered buttons to enter the code number.

The remote control outputs the on/off signal.

If the code is correct, the equipment turns on or off.

If it doesn't, try entering another code.

- Note that this remote control cannot operate some equipment and that it may not be able to perform some operations.
- Reenter the codes after you change the batteries.

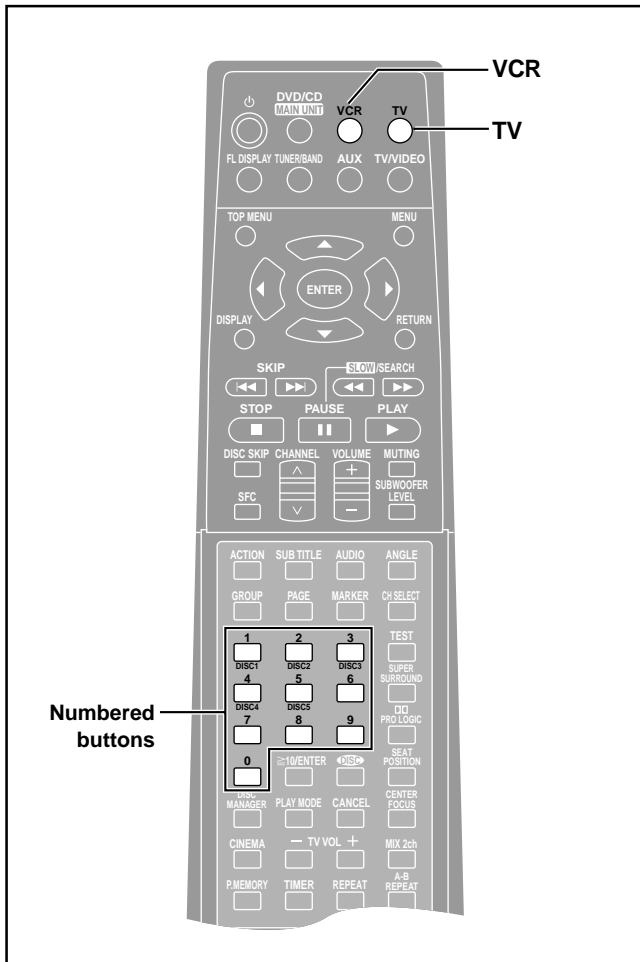

Numbered buttons

Television code list

Panasonic:	01, 02, 26	Philco:	06, 07
Sony:	04	Philips:	06
Fisher:	14	Pioneer:	02, 10, 19
G-E:	02, 03, 07, 09	Quasar:	02
Gold Star:	07, 15	RCA:	03, 07, 09, 13, 23, 24, 25
Hitachi:	05, 07	Sanyo:	14
JVC:	12	Sharp:	08, 21
LXI:	03, 06, 07, 10, 14, 15	Sylvania:	06, 07, 15
Magnavox:	06, 07, 11, 15, 22	Symphonic:	17
Mitsubishi:	07, 15, 16, 21	Toshiba:	10, 21
NEC:	07, 15	Zenith:	18, 20

Video cassette recorder code list

Panasonic:	01, 02, 09, 33	NEC:	19, 25, 31, 38
Sony:	05, 06, 07, 35, 36, 37	Philco:	02, 09, 12, 30
Fisher:	13, 14, 15, 18, 34	Philips:	02, 09, 12
Funai:	08, 30	Pioneer:	09
G-E:	02, 03, 11	Quasar:	01, 02, 09, 33
Gold Star:	27	RCA:	02, 03, 04, 09, 10, 11, 12, 23, 24, 26
Hitachi:	09, 10, 11	Sanyo:	14, 18, 34
JVC:	19, 25, 31, 38, 39, 40	Sharp:	16, 17
LXI:	10, 13, 14, 15, 18, 27, 30	Shintom:	32
Magnavox:	02, 09, 12	Sylvania:	02, 09, 12, 30
Mitsubishi:	21, 22, 28, 29	Symphonic:	30
		Toshiba:	23, 24
		Zenith:	20

Listening to an external source/Recording to other equipment

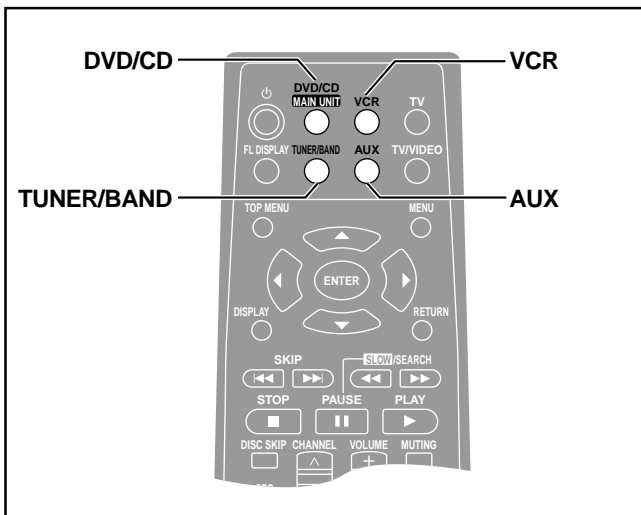

- Turn the unit off before making connections.
- Refer to the manual of the other unit for details.
(Cables and equipment not included.)

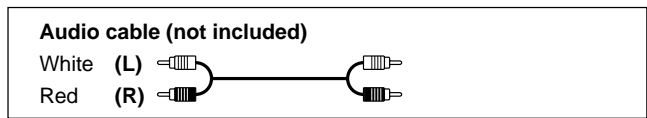

Video cassette recorder (not included)

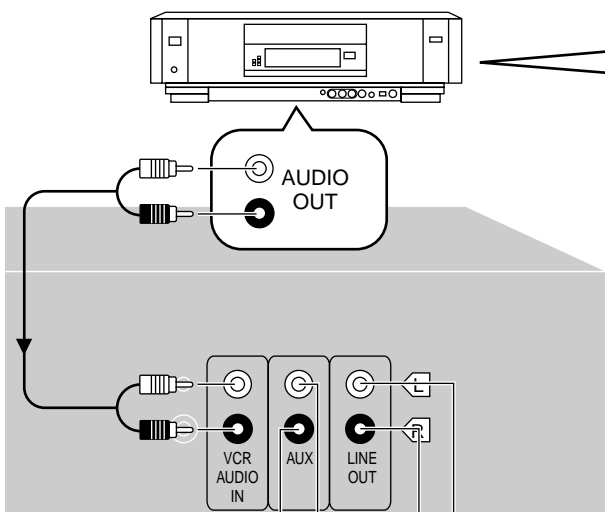

You can playback the sound from a video cassette recorder through this unit's speaker.

- 1 Press [VCR].**
 - Main unit: Press [SELECTOR].
Each time you press the button:
DVD/CD → FM → AM → TV → VCR → AUX
- 2 Start play.**

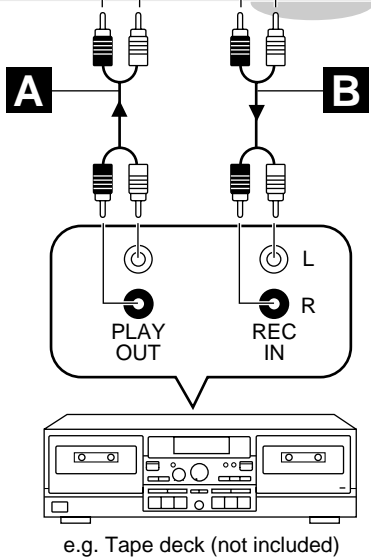

e.g. Tape deck (not included)

- A** You can playback the sound from a tape deck/laser disc player, etc., through this unit's speaker.
- 1 Press [AUX].**
 - Main unit: Press [SELECTOR].
Each time you press the button:
DVD/CD → FM → AM → TV → VCR → AUX
 - 2 Start play.**

- B** You can record sound from the radio or discs, etc. to a tape deck.
- **Disc**
Press [DVD/CD] to select "DVD/CD".
 - **The radio**
Press [TUNER/BAND] to select "FM" or "AM".
 - Main unit → see above.
 - 2 Start recording and play.**

When connecting a record player

We recommend using a record player with a built-in phono equalizer. If your player doesn't have a built-in equalizer, connect it first to a separate equalizer and then connect that to this unit.

Other functions

Optional antenna connections

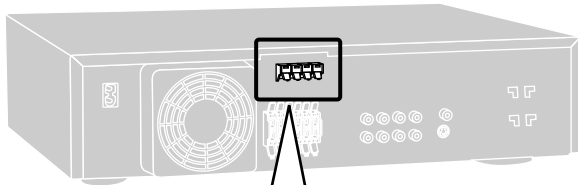

Use outdoor antennas if radio reception is poor.

A FM outdoor antenna (Using a television antenna)

- Disconnect the FM indoor antenna.
- The antenna should be installed by a competent technician.

B AM outdoor antenna (Using a vinyl wire)

Run a piece of vinyl wire horizontally across a window or other convenient location.
Leave the loop antenna connected.

Note

Disconnect the outdoor antenna when the unit is not in use.
Do not use the outdoor antenna during an electrical storm.

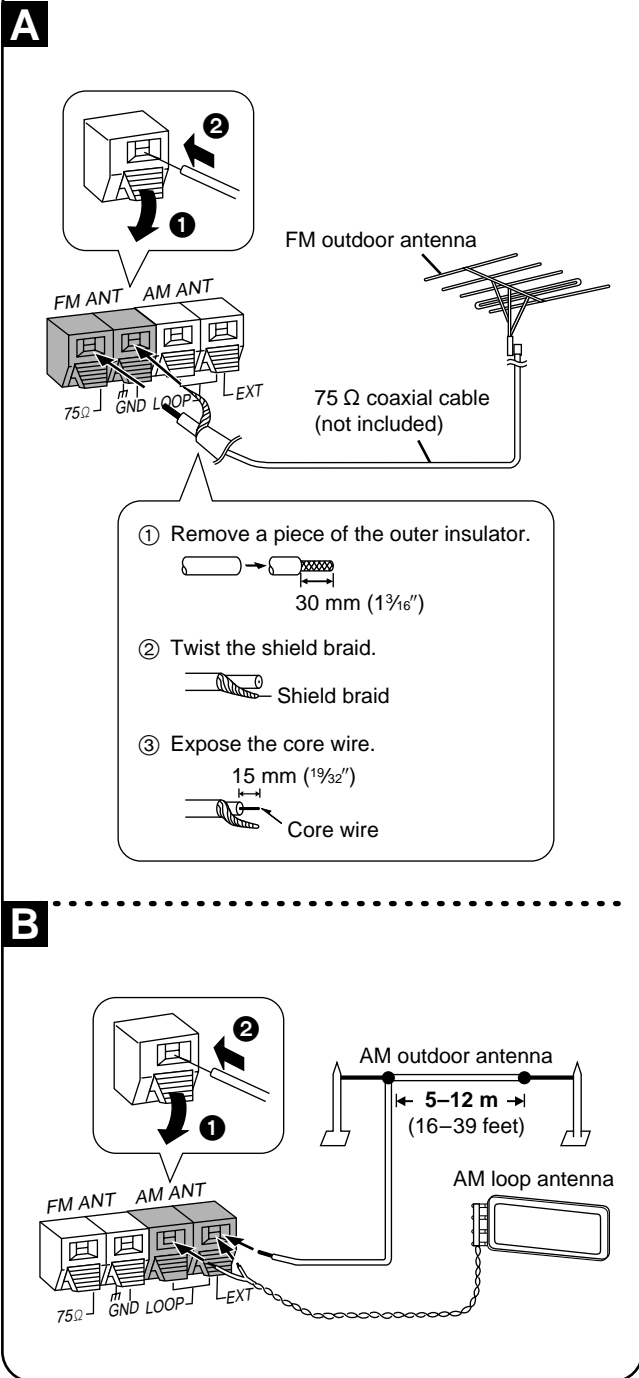

Troubleshooting guide

Before requesting service, make the below checks. If you are in doubt about some of the check points, or if the remedies indicated in the chart do not solve the problem:

In the U.S.A., contact the Panasonic Customer Call Center at 1-800-211-7262, or e-mail consumerproducts@panasonic.com, or web site (<http://www.panasonic.com>).

In Canada, contact Panasonic Canada Inc. Customer Care Centre at 1-800-561-5505, web site (www.panasonic.ca), or an authorized Servicentre closest to you.

In other areas, consult your dealer.

Reference pages are shown as black circled numbers ⑨.

Power

No power.	● Insert the AC power supply cord securely into the household AC outlet. ⑨
The unit is automatically switched to the standby mode.	● The unit was switched to standby by the sleep timer. 27

Operation

No response when buttons pressed.	<ul style="list-style-type: none"> ● Some operations may be prohibited by the disc. ● The unit may not be operating properly due to lightning, static electricity or some other external factor. <p>Reset procedure: Press [⏻] to switch the unit to the standby mode and then back to ON. Alternatively, press [⏻] to switch the unit to the standby mode, disconnect the AC power supply cord, and then reconnect it.</p>
No operations can be performed with the remote control.	<ul style="list-style-type: none"> ● Check the batteries are installed correctly. 10 ● The batteries are depleted: Replace them with new ones. 10 ● Point the remote control at the remote control sensor and operate. ● It may be in the television or video cassette recorder operation mode. Press [DVD/CD] to operate this unit. ● If the remote control doesn't operate the television or video cassette recorder, try changing the code. This remote control cannot operate some televisions or video cassette recorders. 30 31
Play fails to start even when [▶] (PLAY) is pressed. Play starts but then stops immediately.	<ul style="list-style-type: none"> ● Condensation has formed: Wait 1 to 2 hours for it to evaporate. ● This unit cannot play discs other than DVD-Audio, DVD-Video, CD and Video CD. 5 ● You can only play DVD-Video if their region number is the same or includes the same region number as the unit or if the DVD-Video is marked "ALL". Confirm the region number for the unit on the rear panel. 5 ● The disc may be dirty and may require cleaning. 5 ● Ensure that the disc is installed with the label of the side to be played facing upwards. 12
Alternative languages fail to be selected.	<ul style="list-style-type: none"> ● An alternative language is not selected with discs which do not contain more than one language. ● In the case of some discs, the alternative language cannot be selected with [AUDIO] or [SUB TITLE]. Try selecting it from the disc's menu if one is available. 12
No menu play.	● Menus are only displayed if they are recorded on the disc.
No subtitles.	<ul style="list-style-type: none"> ● Subtitles appear only with discs that contain them. ● Subtitles are cleared from the television. Display the subtitles. 18
Soundtrack and/or subtitle language is not the one selected with the ACTION menus.	● The language is not recorded on the disc.
Angle cannot be changed.	● This function is dependent on software availability. Even if a disc has a number of angles recorded, these angles may be recorded for specific scenes only. 18
The ACTION menu cannot be accessed.	<ul style="list-style-type: none"> ● Select "DVD/CD" as the source. ● Cancel program and random play. 17
You have forgotten your ratings password. Reset all the settings to Factory Preset.	● While stopped, press and hold [■] on the unit and [≥10/ENTER] on the remote control for about 3 seconds until "Initialized" disappears from the television. Turn the unit off and on again. All settings will return to the default values.

Sound

No sound. Distorted sound.	<ul style="list-style-type: none"> ● Check the connections. 7 8 9 32 ● Turn the volume up. ● Turn muting off. 27 ● Switch off the unit, determine and correct the cause, then switch the unit on. Causes include: <ul style="list-style-type: none"> – Shorting (bare wires touching) of positive and negative speaker wires. 7 – Using speakers with an impedance lower than that rated for this unit. 37 – Straining of the speakers through excessive volume or power. – Using the unit in a hot environment without proper ventilation.
Humming heard during play.	<ul style="list-style-type: none"> ● An AC power supply cord or fluorescent light is near the cables. Keep other appliances and cords away from this unit's cables. ● If possible in your area, turn the AC power supply cord's plug or connector over to reverse the plug's polarity.
No sound from the subwoofer.	● Check that the subwoofer has not been set to "0". 26

Picture

<p>Picture distorted.</p> <p>No picture.</p>	<ul style="list-style-type: none"> •Some distortion is normal during SEARCH. •Ensure that the television is connected properly. ③ •Make sure the television is on. •Ensure the television's video input setting (e.g., VIDEO 1) is correct. •If "This disc is PAL system. The output is sound only." is on the television, then you have loaded a PAL system DVD-Audio and only the audio portion of the disc can be played. <p>HT95</p> <ul style="list-style-type: none"> •The unit does not output video signals from the VIDEO OUT and S-VIDEO OUT terminals when the "PROGRESSIVE OUT" indicator is on. Press [PROGRESSIVE OUT] to turn progressive out off.
<p>The picture shown on the television is not normal.</p>	<ul style="list-style-type: none"> •Ensure that the unit is connected directly to the television, and is not connected through a video cassette recorder. •Go to the Video menu in the ACTION screen, and change "TV Aspect" to suit your television. You may also need to change the screen mode on the television itself. ⑩ <p>HT95</p> <p>If your television cannot change the aspect when input is progressive Press [PROGRESSIVE OUT] so the indicator goes out. Output will now be interlace.</p>
<p>HT95</p> <p>There is ghosting when progressive output is on.</p>	<ul style="list-style-type: none"> •Turn progressive output off. This problem is caused by the editing method or material used on the DVD, but should be corrected if you use interlace output.
<p>Picture quality is poor.</p>	<ul style="list-style-type: none"> •Check the settings in the On-Screen Menu Icons' video menu. ④ •Adjust the horizontal position with the on-screen menu icons. ④
<p>HT95</p> <p>The picture is off center when using progressive output.</p>	
<p>The picture on the television disappears or stripes appear on the screen.</p>	<ul style="list-style-type: none"> •The location and orientation of the antenna are incorrect. If you are using an indoor antenna, change to an outdoor antenna. ③ •The television antenna wire is too close to the unit. Separate the antenna wire of the television from the unit.

Listening to the radio

<p>Noise is heard.</p> <p>The stereo indicator flickers or doesn't light.</p> <p>Sound is distorted.</p>	<ul style="list-style-type: none"> •Adjust the position of the FM or AM antenna. ⑨ •Use an outdoor antenna. ③
<p>A beat sound is heard.</p>	<ul style="list-style-type: none"> •Turn the television off or separate it from the unit.
<p>A low hum is heard during AM broadcasts.</p>	<ul style="list-style-type: none"> •Separate the antenna from other cables and cords.

Unit displays

<p>This unit's display is off.</p>	<ul style="list-style-type: none"> •Press [FL DISPLAY] to turn the display on. ⑦
<p>"NO PLAY"</p>	<ul style="list-style-type: none"> •You inserted a disc the unit cannot play; insert one it can. ⑤
<p>"NO DISC"</p>	<ul style="list-style-type: none"> •You haven't inserted a disc; insert one. •You haven't inserted the disc correctly; insert it correctly. ⑫
<p>"F61"</p>	<ul style="list-style-type: none"> •Check and correct the speaker cord connections. ⑦ If this does not fix the problem, there is a power supply problem. Consult the dealer.
<p>"DVD U11"</p>	<ul style="list-style-type: none"> •The disc is dirty. Wipe it with a soft cloth. ⑤
<p>"ERROR"</p>	<ul style="list-style-type: none"> •Incorrect operation performed. Read the instructions and try again. •The track playing has been recorded with a nonstandard system.
<p>"DVD H□□"</p> <p>□□ stands for a number.</p>	<ul style="list-style-type: none"> •Trouble is likely to have occurred. The number following "H" depends on the status of the unit. <p>Reset procedure: Press [⏻] to switch the unit to the standby mode and then back to ON. Alternatively, press [⏻] to switch the unit to the standby mode, disconnect the AC power supply cord, and then reconnect it. •If the service numbers fail to clear, note the service number and contact a qualified service person. </p>
<p>"TAKE OUT DISC"</p>	<ul style="list-style-type: none"> •A problem has occurred with the tray mechanism. The tray will open automatically. Take out the disc and close the tray. The unit will make the disc changing noises for a few moments and then should operate normally.

Television displays

<p>No on-screen display.</p>	<ul style="list-style-type: none"> •Go to Display in the ACTION menus, and select "On" for "On-Screen Messages". ⑫
<p>On-Screen Menu Icons not displayed or only partially displayed on the television.</p>	<ul style="list-style-type: none"> •Press [▲, ▼] while the rightmost icon is highlighted to move them down. ⑩
<p>The disc's menu is displayed in a different language.</p>	<ul style="list-style-type: none"> •Go to Disc in the ACTION menus, and select the preferred language for "Menu". ⑫

Maintenance

To clean this unit, wipe with a soft, damp cloth.

- Never use alcohol, paint thinner or benzene to clean this unit.
- Before using chemically treated cloth, read the instructions that came with the cloth carefully.

Before moving the unit, ensure the disc tray is empty.
Failure to do so will risk severely damaging the disc and the unit.

Bitstream

This is the digital form of multiple channel audio data (e.g., 5.1 channel) before it is decoded into its various channels.

Decoder

A decoder restores the coded audio signals on DVDs to normal. This is called decoding.

Dolby Digital

This is a method of coding digital signals developed by Dolby Laboratories. Apart from stereo (2-channel) audio, these signals can also be 5.1-channel audio. A large amount of audio information can be recorded on one disc using this method.

Dolby Pro Logic

A surround system where a 4-channel audio track is recorded as 2 channels and then is restored to 4 channels for play. The surround channel is monaural and can reproduce up to 7 kHz.

DTS (Digital Theater Systems)

This surround system is used in many movie theaters around the world. There is good separation between the channels, so realistic sound effects are possible.

Dynamic range

Dynamic range is the difference between the lowest level of sound that can be heard above the noise of the equipment and the highest level of sound before distortion occurs.

Film and video

DVDs are recorded using either film or video. Usually, film is recorded at 24 frames per second, the rate movies are filmed at, while video is recorded at 30 frames per second.

Frame still and field still

Frames are the still pictures that go together to make a moving picture. There are about 30 frames shown each second.

One frame is made up of two fields. A regular television shows these fields one after the other to create frames.

A still is shown when you pause a moving picture. A frame still is made up of two alternating fields, so the picture may appear blurred, but overall quality is high.

A field still is not blurred, but it has only half the information of a frame still so picture quality is lower.

Interlace and progressive output

NTSC, the video signal standard, has 480 interlaced (i) scan lines, whereas progressive scanning uses twice the number of scan lines. This is called 480p.

The 480i video signals output from this unit's COMPONENT VIDEO OUT terminals (Y, P_B, P_R) allow you to enjoy higher quality pictures than if the signals were output from the video output terminal or S-VIDEO OUT terminal. The COMPONENT VIDEO OUT terminals are also able to handle 480p (progressive) video signals which are of even greater resolution.

I/P/B

MPEG 2, the video compression standard adopted for use with DVD-Video, codes frames using these 3 picture types.

I: Intra coded picture (I-picture)

This is the standard picture and is a complete picture in itself.

This means it has the best picture quality and is the best to use when adjusting the picture.

P: Predictive coded picture (P-picture)

This picture is calculated based on past I or P-pictures.

B: Bidirectionally-predictive coded picture (B-picture)

This picture is calculated by comparing past and future I and P-pictures so it has the lowest volume of information.

Linear PCM (pulse code modulation)

These are uncompressed digital signals, similar to those found on CDs.

MP3

A method of compressing audio, MPEG Audio Layer 3 (MP3) allows audio to be reduced to up to one tenth its original size without overtly hurting audio quality.

When creating MP3 files to play on this unit

- Disc formats: ISO9660 level 1 and level 2 (except for extended formats)

Files: MP3 files with the suffix ".mp3" or ".MP3"

- To have this unit play files in a certain order, prefix folder and file names with numbers in the order you want to play them. This may not work in all cases.

Not compatible with multi-session recordings

If you record MP3 onto CD-R/CD-RW over a number of sessions, this unit can play only the recordings made in the first session.

Playback control (PBC)

If a Video CD has playback control, you can select scenes and information with menus.

Language code list

Abkhazian: 6566	Chinese: 9072	Hausa: 7265	Lithuanian: 7684	Romanian: 8279	Telugu: 8469
Afar: 6565	Corsican: 6779	Hebrew: 7387	Macedonian: 7775	Russian: 8285	Thai: 8472
Afrikaans: 6570	Croatian: 7282	Hindi: 7273	Malagasy: 7771	Samoan: 8377	Tibetan: 6679
Albanian: 8381	Czech: 6783	Hungarian: 7285	Malay: 7783	Sanskrit: 8365	Tigrinya: 8473
Ameharic: 6577	Danish: 6865	Icelandic: 7383	Malayalam: 7776	Scots Gaelic: 7168	Tonga: 8479
Arabic: 6582	Dutch: 7876	Indonesian: 7378	Maltese: 7784	Serbian: 8382	Turkish: 8482
Armenian: 7289	English: 6978	Interlingua: 7365	Maori: 7773	Serbo-Croatian: 8372	Turkmen: 8475
Assamese: 6583	Esperanto: 6979	Irish: 7165	Marathi: 7782	Shona: 8378	Twi: 8487
Aymara: 6588	Estonian: 6984	Italian: 7384	Moldavian: 7779	Sindhi: 8368	Ukrainian: 8575
Azerbaijani: 6590	Faroese: 7079	Japanese: 7465	Mongolian: 7778	Singhalese: 8373	Urdu: 8582
Bashkir: 6665	Fiji: 7074	Javanese: 7487	Nauru: 7865	Slovak: 8375	Uzbek: 8590
Basque: 6985	Finnish: 7073	Kannada: 7578	Nepali: 7869	Slovenian: 8376	Vietnamese: 8673
Bengali; Bangla: 6678	French: 7082	Kashmiri: 7583	Norwegian: 7879	Somali: 8379	Volapük: 8679
Bhutani: 6890	Frisian: 7089	Kazakh: 7575	Oriya: 7982	Spanish: 6983	Welsh: 6789
Bihari: 6672	Galician: 7176	Kirghiz: 7589	Pashto, Pushto: 8083	Sundanese: 8385	Wolof: 8779
Breton: 6682	Georgian: 7565	Korean: 7579	Persian: 7065	Swahili: 8387	Xhosa: 8872
Bulgarian: 6671	German: 6869	Kurdish: 7585	Polish: 8076	Swedish: 8386	Yiddish: 7473
Burmese: 7789	Greek: 6976	Laotian: 7679	Portuguese: 8084	Tagalog: 8476	Yoruba: 8979
Byelorussian: 6669	Greenlandic: 7576	Latin: 7665	Punjabi: 8065	Tajik: 8471	Zulu: 9085
Cambodian: 7577	Guarani: 7178	Latvian, Lettish: 7686	Quechua: 8185	Tamil: 8465	
Catalan: 6765	Gujarati: 7185	Lingala: 7678	Rhaeto-Romance: 8277	Tatar: 8484	

Specifications

AMPLIFIER SECTION **HT95**

FTC TTL POWER OUTPUT	360 W
120 Hz–20 kHz, 1.0 % total harmonic distortion	
FRONT	30 W per ch (6 Ω)
CENTER	80 W (6 Ω)
SURROUND	38 W per ch (6 Ω)
45 Hz–120 Hz, 1.0 % total harmonic distortion	
SUBWOOFER	144 W (6 Ω)
RMS TTL POWER OUTPUT	500 W
1 kHz, 10 % total harmonic distortion	
FRONT	46 W per ch (6 Ω)
CENTER	106 W (6 Ω)
SURROUND	56 W per ch (6 Ω)
100 Hz, 10 % total harmonic distortion	
SUBWOOFER	190 W (6 Ω)
Input sensitivity/input impedance	
AUX	250 mV, 10 kΩ

AMPLIFIER SECTION **HT75 for U.S.A. and Canada**

FTC TTL POWER OUTPUT	300 W
120 Hz–20 kHz, 1.0 % total harmonic distortion	
FRONT	30 W per ch (6 Ω)
CENTER	35 W (6 Ω)
SURROUND	35 W per ch (6 Ω)
45 Hz–120 Hz, 1.0 % total harmonic distortion	
SUBWOOFER	135 W (6 Ω)
RMS TTL POWER OUTPUT	400 W
1 kHz, 10 % total harmonic distortion	
FRONT	46 W per ch (6 Ω)
CENTER	46 W (6 Ω)
SURROUND	46 W per ch (6 Ω)
100 Hz, 10 % total harmonic distortion	
SUBWOOFER	170 W (6 Ω)
Input sensitivity/input impedance	
AUX	250 mV, 10 kΩ

AMPLIFIER SECTION **HT75 for Latin America and others**

RMS TTL POWER OUTPUT	400 W
1 kHz, 10 % total harmonic distortion	
FRONT	41 W per ch (6 Ω)
CENTER	42 W (6 Ω)
SURROUND	52 W per ch (6 Ω)
100 Hz, 10 % total harmonic distortion	
SUBWOOFER	172 W (6 Ω)
PMPO TTL POWER OUTPUT	2300 W
Input sensitivity/input impedance	
AUX	250 mV, 10 kΩ

FM TUNER SECTION

Frequency range	
For U.S.A., Canada and others	87.9–107.9 MHz (200 kHz steps) 87.5–108.0 MHz (100 kHz steps)
For Latin America	87.50–108.00 MHz (50 kHz steps)
Antenna terminals	75 Ω unbalanced

AM TUNER SECTION

Frequency range	
For U.S.A., Canada and others	520–1710 kHz (10 kHz steps)
For Latin America	522–1629 kHz (9 kHz steps) 520–1630 kHz (10 kHz steps)

DISC SECTION

Compatible disc types	DVD-AUDIO DVD-VIDEO DVD-R (DVD-VIDEO formatted) CD (CD-DA), VIDEO-CD CD-R/RW (CD-DA, VIDEO-CD, or MP3 format)
------------------------------	---------------------------------------------------------------------------------------------------------------------------

Audio	
Number of channels	5.1 (FL, FR, SL, SR, C, SW)
Video	
Signal system	NTSC
Output terminal	RCA (composite video) S terminal (Y, C) RCA (component video)
Progressive scan HT95	
Pick up	
Beam Source	Semiconductor Laser
Wavelength	
CD/VCD	790 nm
DVD	658 nm

SPEAKER SECTION

HT95 SB-AFC95	Surround speakers
HT75 SB-AFC95	Front and surround speakers
Type	1 way 1 speaker Bass-ref.
Speaker	
Full range	8 cm (3 ¹ / ₈ ") cone type
Impedance	6 Ω
Input power	60 W (music)
Output sound pressure level	79 dB/W (1.0 m)
Frequency range	80 Hz–22 kHz (–16 dB) 110 Hz–20 kHz (–10 dB)
Dimensions (W×H×D)	88×135×112 mm (3 ¹ / ₂ "×5 ¹ / ₂ "×4 ⁷ / ₁₆ ")
Mass	Approx. 0.8 kg (1.8 lb.)

HT95 SB-AFC286	Front and center speakers
Type	2 way 2 speaker Bass-ref.
Speaker unit	
Woofer	10 cm (4") cone type
Tweeter	6 cm (2 ³ / ₈ ") cone type
Impedance	6 Ω
Input power	110 W (music)
Output sound pressure level	83 dB/W (1.0 m)
Cross over frequency	4 kHz
Frequency range	67 Hz–22 kHz (–16 dB) 92 Hz–20 kHz (–10 dB)
Dimensions (W×H×D)	120×208×163 mm (4 ³ / ₄ "×8 ³ / ₁₆ "×6 ⁷ / ₁₆ ")
Mass	Approx. 1.9 kg (4.2 lb.)

HT75 SB-PC89	Center speaker
Type	1 way 1 speaker Bass-ref.
Speaker	
Full range	8 cm (3 ¹ / ₈ ") cone type
Impedance	6 Ω
Input power	60 W (music)
Output sound pressure level	79 dB/W (1.0 m)
Frequency range	80 Hz–22 kHz (–16 dB) 110 Hz–20 kHz (–10 dB)
Dimensions (W×H×D)	135×88×112 mm (5 ¹ / ₂ "×3 ¹ / ₂ "×4 ⁷ / ₁₆ ")
Mass	Approx. 0.8 kg (1.8 lb.)

HT95 SB-W81	Subwoofer
Type	1 way 1 speaker Bass-ref.
Speaker unit	
Woofer	17 cm (6 ³ / ₄ ") cone type
Impedance	6 Ω
Input power	200 W (music)
Output sound pressure level	80 dB/W (1.0 m)
Frequency range	41 Hz–1.8 kHz (–16 dB) 45 Hz–1.6 kHz (–10 dB)
Dimensions (W×H×D)	200×450×300 mm (7 ⁷ / ₈ "×17 ² / ₃₂ "×11 ¹ / ₁₆ ")
Mass	Approx. 5.9 kg (13.0 lb.)

HT75 SB-W95	Subwoofer
Type	1 way 1 speaker Bass-ref.
Speaker unit	
Woofer	17 cm (6 ³ / ₄ ") cone type
Impedance	6 Ω
Input power	200 W (music)
Output sound pressure level	80 dB/W (1.0 m)
Frequency range	42 Hz–1.5 kHz (–16 dB) 46 Hz–900 Hz (–10 dB)
Dimensions (W×H×D)	173×315×300 mm (6 ³ / ₁₆ "×12 ¹ / ₂ "×11 ¹ / ₁₆ ")
Mass	Approx. 4.0 kg (8.8 lb.)

GENERAL **For U.S.A. and Canada**

Power supply	AC 120 V, 60 Hz
Power consumption	190 W
Dimensions (W×H×D)	430×114×368 mm (16 ¹ / ₁₆ "×4 ¹ / ₂ "×14 ¹ / ₂ ")
Mass	Approx. 8.4 kg (18.5 lb.)

GENERAL **For Latin America and others**

Power supply	AC 110 V/127 V/220 V–230 V/240 V, 50/60 Hz
Power consumption	171 W
Dimensions (W×H×D)	430×114×368 mm (16 ¹ / ₁₆ "×4 ¹ / ₂ "×14 ¹ / ₂ ")
Mass	Approx. 8.4 kg (18.5 lb.)

Power consumption in standby mode

For U.S.A. and Canada	0.28 W
For Latin America and others	0.80 W

Note

- Specifications are subject to change without notice. Mass and dimensions are approximate.
- Total harmonic distortion is measured by the digital spectrum analyzer.



*For Product Information, Operating Assistance, Literature Request, Dealer Locations, and all Customer Service inquiries please contact:
1-800-211-PANA (7262), Monday–Friday 9 am–9 pm; Saturday–Sunday 9 am–7 pm, EST.*

*Web Site: <http://www.panasonic.com>
You can purchase parts, accessories or locate your nearest servicenter by visiting our Web Site.*

Accessory Purchases:

1-800-332-5368 (Customer Orders Only)
Panasonic Services Company 20421 84th Avenue South, Kent, WA 98032
(6 am to 5 pm Monday–Friday; 6 am to 10:30 am Saturday; PST)
(Visa, MasterCard, Discover Card, American Express, Check)

Factory Servicenters Locations

<p>CALIFORNIA 6550 Katella Avenue Cypress, CA 90630</p> <p>800 Dubuque Avenue S. San Francisco CA 94080</p> <p>3878 Ruffin Road Suite A San Diego, CA 92123</p>	<p>GEORGIA 8655 Roswell Road Suite 100 Atlanta, GA 30350</p> <p>ILLINOIS 1709 North Randall Road Elgin, IL 60123</p> <p>MASSACHUSETTS 60 Glacier Drive Suite G Westwood, MA 02090</p>	<p>MINNESOTA 7850-12th Avenue South Airport Business Center Bloomington, MN 55425</p> <p>OHIO 2236 Waycross Road Civic Center Plaza Forest Park, OH 45240</p> <p>PENNSYLVANIA 2221 Cabot Blvd. West Suite B Langhorne, PA 19047</p>	<p>TEXAS 13615 Welch Road Suite 101 Farmers Branch TX 75244</p> <p>WASHINGTON 20425-84th Avenue South Kent, WA 98032</p> <hr/> <p>HAWAII 99-859 Iwaiwa Street Aiea, Hawaii 96701 Phone (808) 488-1996 Fax (808) 486-4369</p>
------------------------------------------------------------------------------------------------------------------------------------------------------------------------------------------------	--------------------------------------------------------------------------------------------------------------------------------------------------------------------------------------------------------------------------------------------	---------------------------------------------------------------------------------------------------------------------------------------------------------------------------------------------------------------------------------------------------------------------------------------------------------	------------------------------------------------------------------------------------------------------------------------------------------------------------------------------------------------------------------------------------------------------------------------------------------------------

Reference

Service in Puerto Rico

*Matsushita Electric of Puerto Rico, Inc. Panasonic Sales Company/Factory Servicenter:
Ave. 65 de Infanteria, Km. 9.5, San Gabriel Industrial Park, Carolina, Puerto Rico 00985
Phone (787) 750-4300 Fax (787) 768-2910*

Limited Warranty (U.S.A.)

Panasonic Consumer Electronics Company,
Division of Matsushita Electric Corporation of America
One Panasonic Way Secaucus, New Jersey 07094

Panasonic Sales Company, Division of Matsushita Electric
of Puerto Rico, Inc.
Ave. 65 de Infantería, Km. 9.5
San Gabriel Industrial Park, Carolina, Puerto Rico 00985

Panasonic/Technics Audio Products Limited Warranty

Panasonic Consumer Electronics Company or Panasonic Sales Company (collectively referred to as "the Warrantor") will repair or replace this product with new or refurbished parts or equivalent product, free of charge in the U.S.A. or Puerto Rico, in the event of a defect in materials or workmanship as follows (all time periods commence from the date of original purchase):

AUDIO PRODUCTS—labor and parts for one (1) year.

ALL AUDIO RACKS (cabinets)—parts only 30 days.

TECHNICS STAND ALONE SPEAKERS, SUBWOOFER SPEAKERS—labor and parts for three (3) years.

USB READER-WRITER, PERSONAL COMPUTER CARD ADAPTERS—(when applicable)—exchange defective unit with a new or refurbished one for one (1) year.

ACCESSORIES—HEADPHONES, CARTRIDGES, MICROPHONES, ADAPTERS—labor and parts for ninety (90) days.

RECHARGEABLE BATTERIES—(when applicable)—exchange defective item for new one for ten (10) days. Non-rechargeable batteries are not warranted.

SD MEMORY CARDS, RECHARGEABLE BATTERY PACKS—(when applicable)—exchange defective item for new one for ninety (90) days. Non-rechargeable battery packs are not warranted.

Carry-in or mail-in service in the U.S.A. can be obtained during the warranty period by contacting a Panasonic Services Company (PASC) Factory Servicenter listed in the Servicenter Directory. Or call toll free, 1-800-211-7262 to locate a PASC authorized Servicenter. Carry-in or mail-in service in Puerto Rico can be obtained during the warranty period by calling the Panasonic Sales Company telephone number listed in the Servicenter Directory.

This warranty is extended only to the original purchaser. A purchase receipt or other proof of date of original purchase will be required before warranty service is rendered.

This warranty only covers failures due to defects in materials and workmanship which occur during normal use and does not cover normal wear to the stylus (when applicable) or a dealer installed cartridge or stylus. The warranty does not cover damages which occur in shipment or failures which are caused by products not supplied by the warrantor, or failures which result from accident, misuse, abuse, neglect, mishandling, faulty installation, misapplication, set-up adjustments, maladjustment of consumer controls, improper operation or maintenance, improper antenna, inadequate signal reception or pick-up, alteration, modification, power line surge, improper voltage supply, lightning damage, commercial use, such as; hotel, office, restaurant, or other business or rental use of the product, or service by anyone other than a PASC Factory Servicenter or a PASC authorized Servicenter, or damage that is attributable to acts of God.

LIMITS AND EXCLUSIONS

There are no express warranties except as listed above.

THE WARRANTOR SHALL NOT BE LIABLE FOR INCIDENTAL OR CONSEQUENTIAL DAMAGES RESULTING FROM THE USE OF THIS PRODUCT, OR ARISING OUT OF ANY BREACH OF THIS WARRANTY, INCLUDING WITHOUT LIMITATION, DAMAGE TO TAPES, RECORDS OR DISCS. ALL EXPRESS AND IMPLIED WARRANTIES, INCLUDING THE WARRANTIES OF MERCHANTABILITY, AND FITNESS FOR A PARTICULAR PURPOSE, ARE LIMITED TO THE APPLICABLE WARRANTY PERIOD SET FORTH ABOVE. Some states do not allow the exclusion or limitation of incidental or consequential damages, or limitations on how long an implied warranty lasts, so the above exclusions or limitations may not apply to you.

This warranty gives you specific legal rights and you may also have other rights which vary from state to state.

If a problem with this product develops during or after the warranty period, you may contact your dealer or Servicenter. If the problem is not handled to your satisfaction, then write to the Consumer Affairs Department at the company address indicated above.

If you ship the product

Carefully pack and send it prepaid, adequately insured and preferably in the original carton. Attach a postage-affixed letter, detailing the complaint, to the outside of the carton. Do NOT send the product to the Executive or Regional Sales offices. They are NOT equipped to make repairs

Product Service (U.S.A. and Canada)

- 1. Damage requiring service**—The unit should be serviced by qualified service personnel if:
 - (a) The AC power supply cord or AC adaptor has been damaged; or
 - (b) Objects or liquids have gotten into the unit; or
 - (c) The unit has been exposed to rain; or
 - (d) The unit does not operate normally or exhibits a marked change in performance; or
 - (e) The unit has been dropped or the cabinet damaged.
- 2. Servicing**—Do not attempt to service the unit beyond that described in these operating instructions. Refer all other servicing to authorized servicing personnel.
- 3. Replacement parts**—When parts need replacing ensure the servicer uses parts specified by the manufacturer or parts that have the same characteristics as the original parts. Unauthorized substitutes may result in fire, electric shock, or other hazards.
- 4. Safety check**—After repairs or service, ask the servicer to perform safety checks to confirm that the unit is in proper working condition.

The servicer will require all components to service your system. Therefore, should service ever be necessary, be sure to bring the entire system.

Product information

For product information or assistance with product operation:

In the U.S.A., contact the Panasonic Customer Call Center at 1-800-211-7262, or e-mail consumerproducts@panasonic.com, or web site (<http://www.panasonic.com>).

In Canada, contact Panasonic Canada Inc. Customer Care Centre at 1-800-561-5505, web site (www.panasonic.ca), or an authorized Servicentre closest to you.

Listening caution



Selecting fine audio equipment such as the unit you've just purchased is only the start of your musical enjoyment. Now it's time to consider how you can maximize the fun and excitement your equipment offers. This manufacturer and the Electronic Industries Association's Consumer Electronics Group want you to get the most out of your equipment by playing it at a safe level. One that lets the sound come through loud and clear without annoying blaring or distortion—and, most importantly, without affecting your sensitive hearing.

We recommend you to avoid prolonged exposure to excessive noise.

Sound can be deceiving. Over time your hearing "comfort level" adapts to higher volumes of sound. So what sounds "normal" can actually be loud and harmful to your hearing.

Guard against this by setting your equipment at a safe level BEFORE your hearing adapts.

To establish a safe level:

- Start your volume control at a low setting.
- Slowly increase the sound until you can hear it comfortably and clearly, and without distortion.

Once you have established a comfortable sound level:

- Set the dial and leave it there.

Taking a minute to do this now will help to prevent hearing damage or loss in the future. After all, we want you listening for a lifetime.

This product may receive radio interference caused by mobile telephones during use. If such interference is apparent, please increase separation between the product and the mobile telephone.

Manufactured under license from Dolby Laboratories. "Dolby", "Pro Logic" and the double-D symbol are trademarks of Dolby Laboratories.

Manufactured under license from Digital Theater Systems, Inc. US Pat. No. 5,451,942, 5,956,674, 5,974,380, 5,978,762 and other world-wide patents issued and pending. "DTS" and "DTS Digital Surround" are registered trademarks of Digital Theater Systems, Inc. © 1996, 2000 Digital Theater Systems, Inc. All rights reserved.

User memo:

DATE OF PURCHASE _____
DEALER NAME _____
DEALER ADDRESS _____

TELEPHONE NUMBER _____

The model number and serial number of this product can be found on either the back or the bottom of the unit. Please note them in the space provided below and keep for future reference.

MODEL NUMBER _____
SERIAL NUMBER _____

Apparatus Claims of U.S. Patent Nos. 4,631,603, 4,577,216, and 4,819,098, licensed for limited viewing uses only.

This product incorporates copyright protection technology that is protected by method claims of certain U.S. patents and other intellectual property rights owned by Macrovision Corporation and other rights owners. Use of this copyright protection technology must be authorized by Macrovision Corporation, and is intended for home and other limited viewing uses only unless otherwise authorized by Macrovision Corporation. Reverse engineering or disassembly is prohibited.

For U.S.A.

Panasonic Consumer Electronics Company, Division of Matsushita Electric Corporation of America
One Panasonic Way Secaucus,
New Jersey 07094
<http://www.panasonic.com>

For units with PX printed on the outer packaging

Matsushita Electric Industrial Co., Ltd.
Corporate Management Division for the Americas
Sales Office for North America
Tokyo Panasonic Sales Section
32nd Floor, World Trade Center 4-1,
Hamamatsu-cho, 2-Chome, Minato-Ku,
Tokyo 105-6132, Japan

Panasonic Sales Company,
Division of Matsushita Electric of Puerto Rico, Inc. ("PSC")
Ave. 65 de Infantería, Km. 9.5
San Gabriel Industrial Park, Carolina,
Puerto Rico 00985

Panasonic Marketing Europe
G.M.B.H. Wiesbaden N.
(a Division of Panasonic Marketing G.M.B.H.)
Military Sales Department
6200 Wiesbaden-Biebrich,
Hagenauerstr. 43
Germany

For Canada

Panasonic Canada Inc.
5770 Ambler Drive
Mississauga, Ontario
L4W 2T3
www.panasonic.ca

For others

Matsushita Electric Industrial Co., Ltd.
Web Site: <http://www.panasonic.co.jp/global/>

En