

SAFETY NOTES ON THE UNIT

WARNING

- To prevent fire or shock hazard, do not expose the unit to rain or moisture.
- Do not use headphones/earphones while driving, cycling, or operating a motorized vehicle. It may create a traffic hazard and is illegal in some areas. It can also be potentially dangerous to play your headphones/earphones at high volume while walking, especially at pedestrian crossings. You should exercise extreme caution or discontinue use in potentially hazardous situations.
- To prevent shock hazards, never open the unit while it is connected to the power source.

CAUTION

- Do not use headphones/earphones at high volume. Hearing experts advise against continuous, loud and extended play. If you experience a ringing in your ears, reduce volume or discontinue use.
- Keep the volume at a moderate level. This will allow you to hear outside sounds and to be considerate to the people around you.

SAFETY NOTES ON POWER SOURCES

To avoid battery leakage, fire, damage, explosion, etc., follow the descriptions below.

DANGER

- Do not carry dry batteries with coins or other metallic objects. It can generate heat if the positive and negative terminals of the batteries are accidentally contacted by a metallic object.

WARNING

- Use only the recommended AC power adaptor (not supplied). Check also the local voltage to avoid a short circuit to the AC power adaptor.
- To disconnect the AC power adaptor, only use the plug and not the cable.
- Do not charge a dry battery.
- Check the \oplus and \ominus on the batteries, and be sure to insert them like the illustration in this manual.

CAUTION

- When you are not going to use your Walkman for a long time, remove the batteries to prevent damage from battery leakage and corrosion.

About This manual

The instructions in this manual are for WM-EX364 and WM-EX362. Before you start reading, check your model number. WM-EX364 is the model used for illustration purposes. Any differences in operation are clearly indicated in the text, for example, "EX364 only".

Precautions

- Do not leave the unit in a location near heat sources, or in a place subject to direct sunlight, excessive dust or sand, moisture, rain, mechanical shock, or in a car with its windows closed.
- Do not wind the headphones/earphones cord around the unit. The buttons may be kept pressed, causing unnecessary battery usage.
- Do not use cassettes longer than 90 minutes except for long continuous playback.
- If the unit has not been used for a long time, set it in the playback mode to warm it up for a few minutes before inserting a cassette.
- For cleaning the case, use a soft cloth slightly moistened with mild detergent solution. Do not use alcohol, benzene or thinner.

If you have any questions or problem concerning your Walkman, please consult your nearest Sony dealer.

Specifications

- Power requirements**
3V DC batteries R6 (AA) x 2/External DC 3V power sources
- Dimensions**
112.9 x 87.6 x 33.4 mm (4 1/2 x 3 1/2 x 1 3/8 inches) (w/h/d) incl. projecting parts and controls
- Mass**
Approx. 130g (4.6 oz) / Approx. 210g (7.5 oz) incl. batteries and a cassette
- Supplied accessories**
Stereo headphones (1)/Belt clip (1)

Design and specifications are subject to change without notice.

Troubleshooting

The volume is not turned up.

- AVLS is set to LIMIT.

The sound is unstable or no audio.

- Insert two R6 (size AA) batteries properly.
- Replace all batteries if they are weak.

Poor tape playback quality.

- Dirty head. Clean the head and tape path with a cotton swab slightly moistened with cleaning fluid or alcohol.

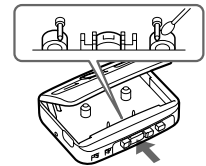

- Clean the headphones/earphones plug.

Location of parts and controls

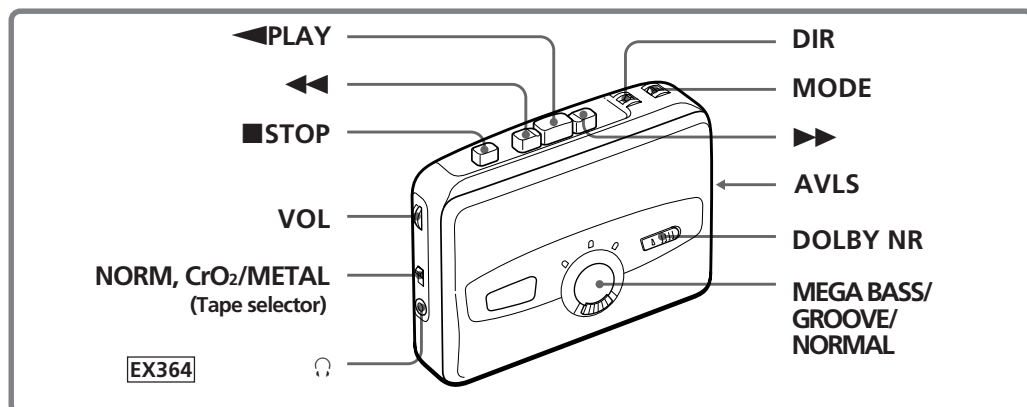

Preparations

To Insert batteries

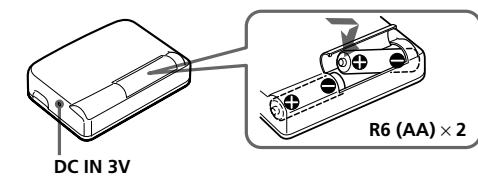

Battery life (approximate hours) (EIAJ*)

	Sony alkaline LR6 (SG)	Sony R6P (SR)
Playback	22	7

* Measured value by the standard of EIAJ (Electronic Industries Association of Japan). (Using a Sony HF series cassette tape)

Notes

- The battery life may shorten depending on the operation of the unit.
- For maximum performance we recommend that you use alkaline batteries.
- If the battery compartment lid comes off, attach it as shown.

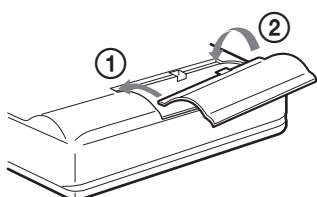

To use external power

- For house current: Connect AC-E30HG AC power adaptor (not supplied) to the DC IN 3V jack. The polarity of the plug is as shown.
- Specifications for AC-E30HG varies for each area. Check your local voltage and the shape of plug before purchasing.

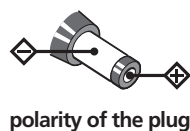

To use the belt clip

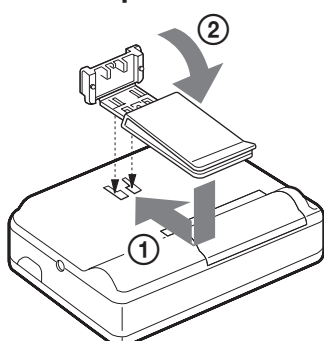

When Using Headphones/Earphones

Wear the "L" marked side to the left ear and the "R" marked side to the right ear.

Playing a tape

- Select NORM or CrO₂/METAL to match the tape type.

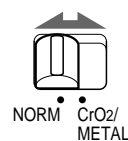

- Insert a cassette and press \blacktriangleleft PLAY.

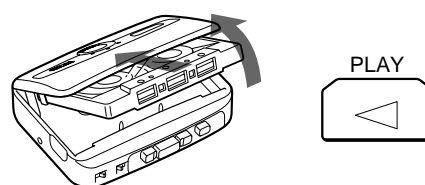

To	Press or Switch
Stop playback*	\blacksquare STOP
Fast-forward or rewind the tape**	$\blacktriangleright\blacktriangleright$ or $\blacktriangleleft\blacktriangleleft$ (For the side facing forward)
Change sides	DIR
Play both sides once	MODE to \blacktriangleright
Play both sides repeatedly	MODE to $\blacktriangleleft\blacktriangleright$

* When the tape direction is set to \blacktriangleright mode, the depressed button \blacktriangleleft PLAY is released automatically at the end of the reverse side (Auto shut-off function).

** Notes on fast-forward and rewind

- Check tape direction and choose $\blacktriangleright\blacktriangleright$ or $\blacktriangleleft\blacktriangleleft$ accordingly.
- If you leave the unit after the tape has been wound or rewound, the batteries will be consumed rapidly. Be sure to press \blacksquare STOP.

To limit the maximum volume automatically

Set AVLS (Automatic Volume Limiter System) to LIMIT. The maximum volume is kept down to protect your ears, even if you turn the volume up. To cancel the AVLS function, set AVLS to NORM.

To emphasize sound

To emphasize deep bass sound, set the switch to MEGA BASS. To emphasize deeper bass sound, set the switch to GROOVE.

To play a tape recorded with Dolby* NR system (EX364 only)

Set DOLBY NR to ON.

* Dolby noise reduction manufactured under license from Dolby Laboratories Licensing Corporation. "DOLBY" and the double-D symbol \square are trademarks of Dolby Laboratories Licensing Corporation.

Notes

- When you set AVLS to LIMIT:
 - the MEGA BASS/GROOVE effect is reduced.
 - turn down the volume, if the bass-boosted sound becomes distorted or unstable.
- Do not open the cassette holder while the tape is running.
- To select the direction of the tape, set MODE to \blacktriangleright for both sides repeatedly or \blacktriangleright for both sides once (from the front side to the reverse side only). If play begins from the reverse side, the tape stops at the end of that side.