

Sagane™

• Lampe • Lamp • Lamp

849 21/23/24

 **legrand**®

- **Caractéristiques techniques**
- **Technische gegevens**
- **Technical data**

	• Lampe • Lamp • Lamp	• Tension • Spanning • Voltage	• Consommation • Verbruik • Consumption
849 21		12 V	0,4 W
849 23		230 V	0,55 mA
849 24		230 V	1,7 mA

- **Câblage**
- **Bedrading**
- **Wiring**

- Câbler votre appareil
- Uw toestel kablere
- Make the electrical connection

849 21
849 23

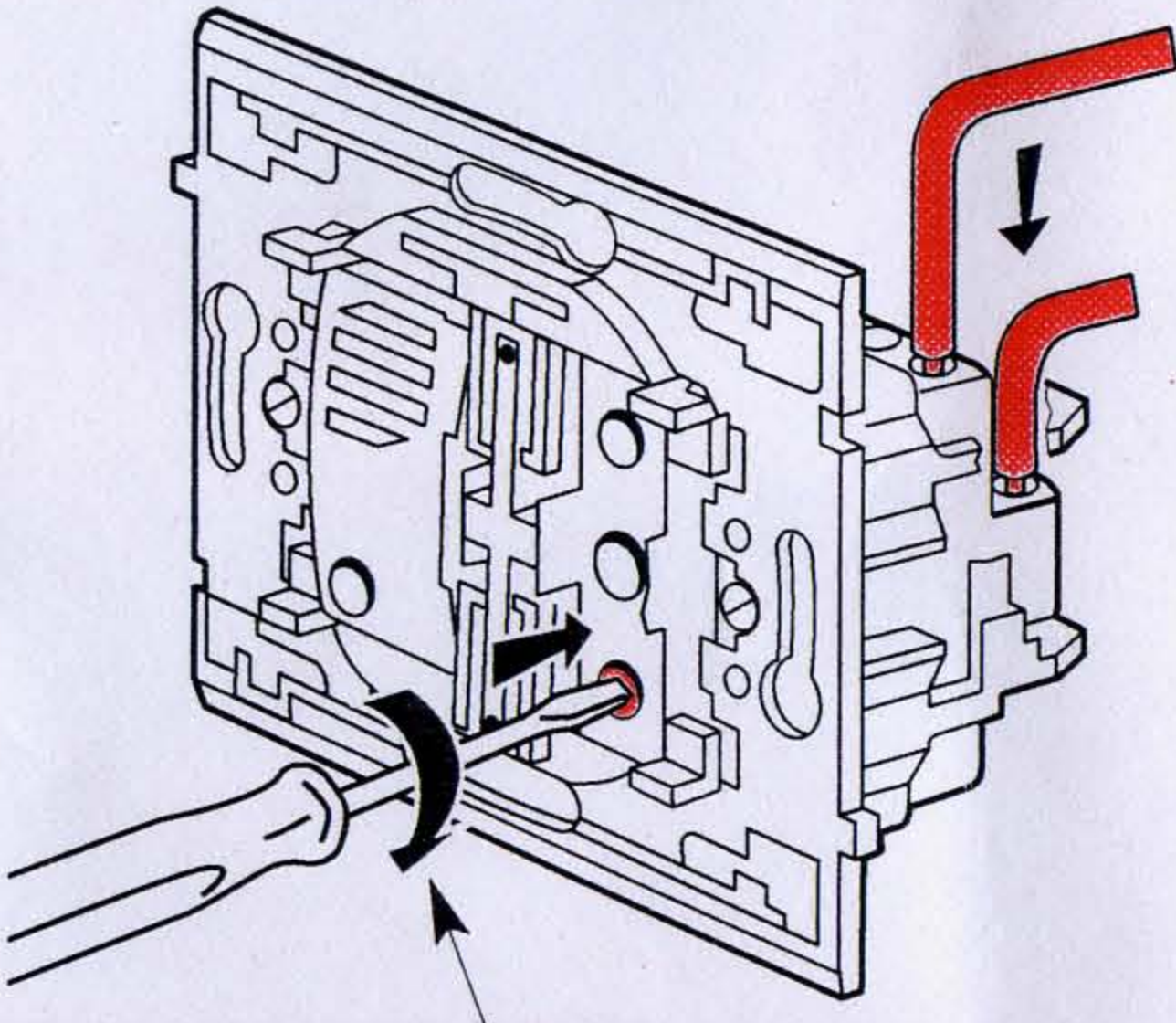

849 24

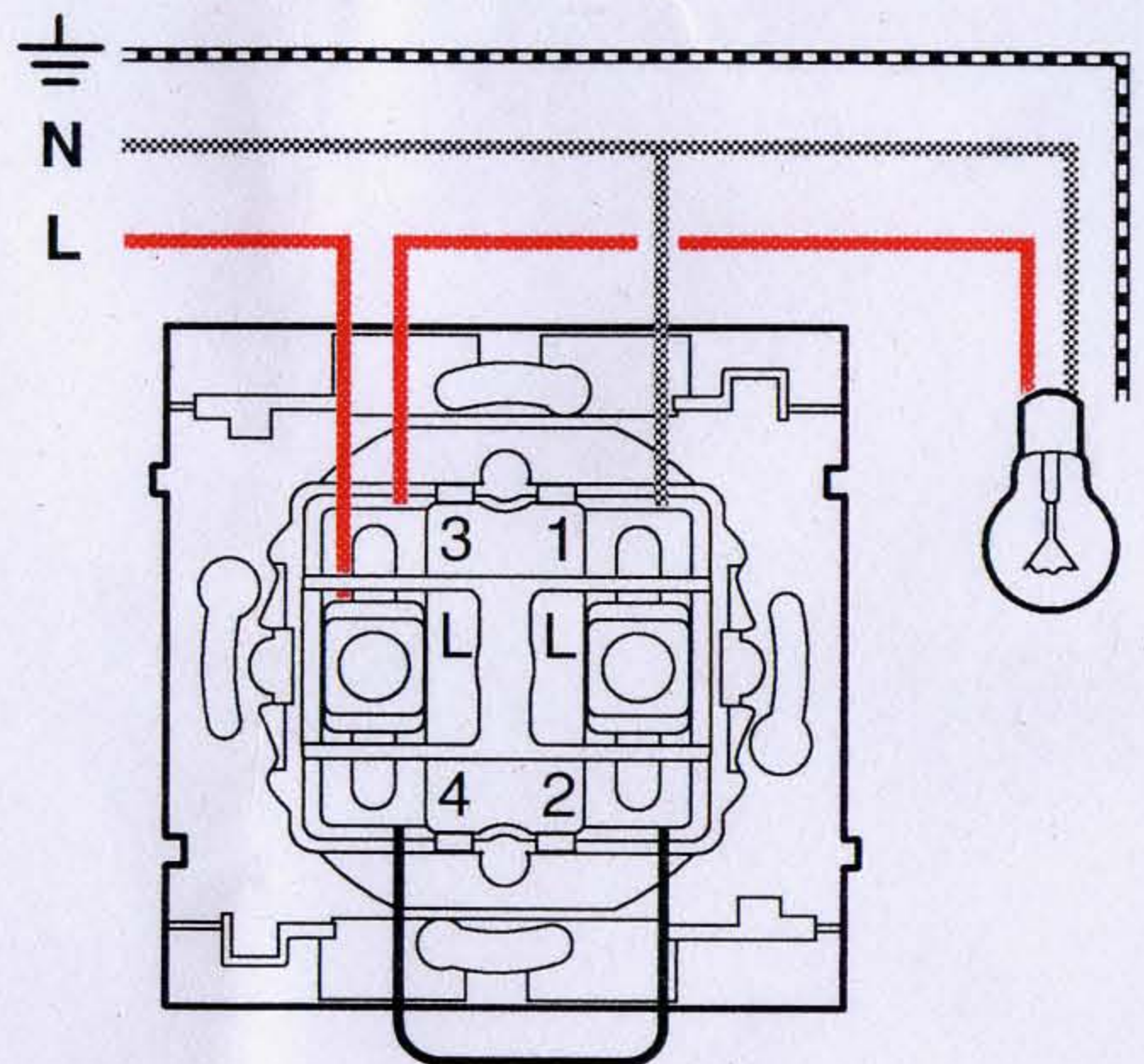

- **Important** : en utilisation en interrupteur lumineux visser la 3eme vis pour assurer le contact
- **Belangrijk** : bij gebruik van een verlichte schakelaar de 3de schroef aanbrengen om het contact tot stand te brengen
- **Important** : when using illuminated switch engage 3rd screw to ensure contact

- **Montage**
- **Montage**
- **Mounting**

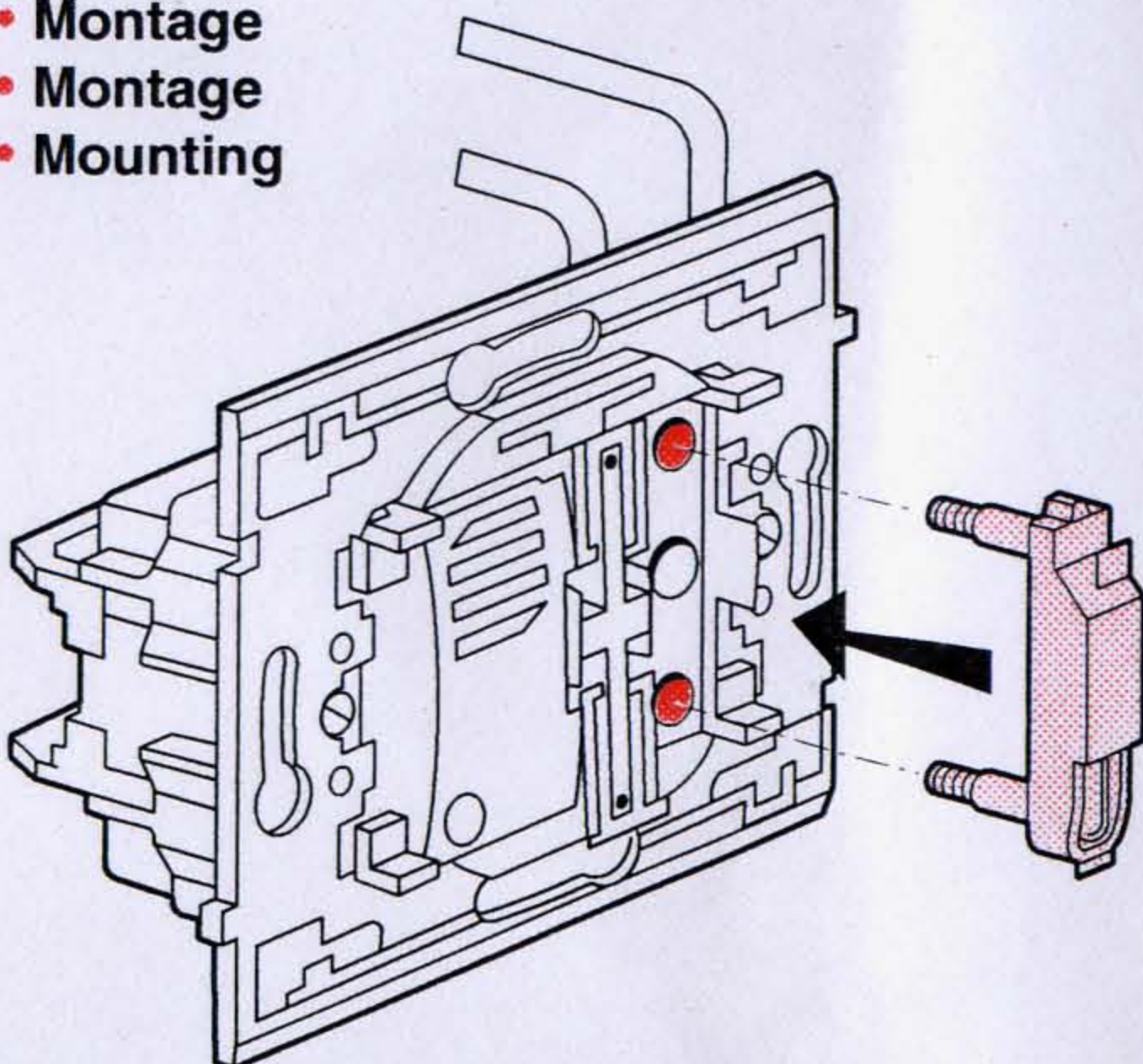

- **Démontage**
- **Demontieren**
- **Dismounting**

