

# Assembly Instructions

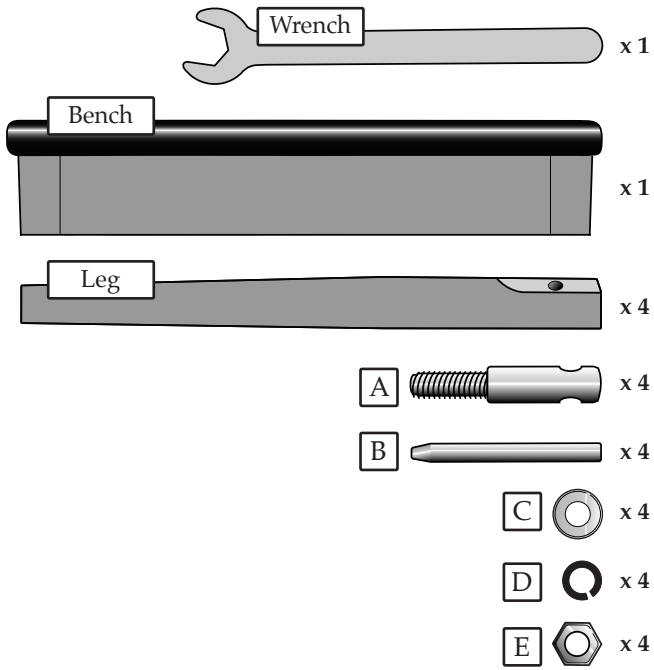

1 Put Screw A through Hole F, lining up the hole in Screw A with Hole G.

2 Drop Pin B (point side down) into Hole G.

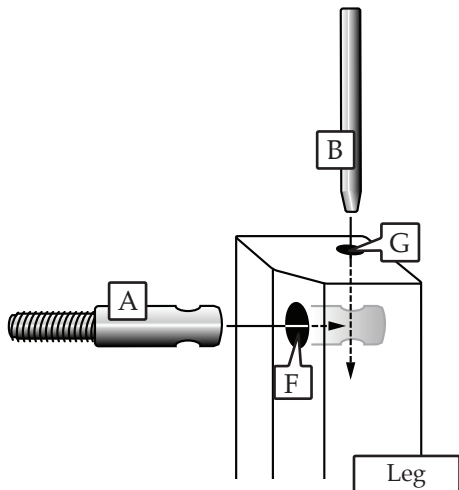

3 Place finger over Hole G (to keep Pin B from falling out) and turn leg upside down.

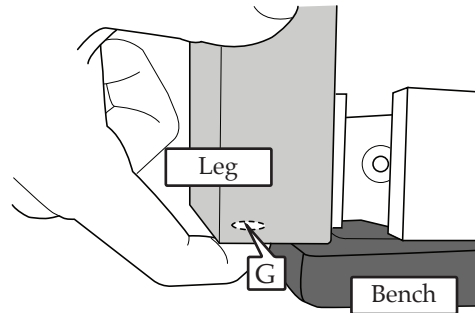

4 With finger still covering Hole G, slide leg into corner of bench, pushing Screw A through hole in bracket.

5 Place Flat Washer C and then Tension Washer D over Screw A, and then tighten Nut E with included wrench.

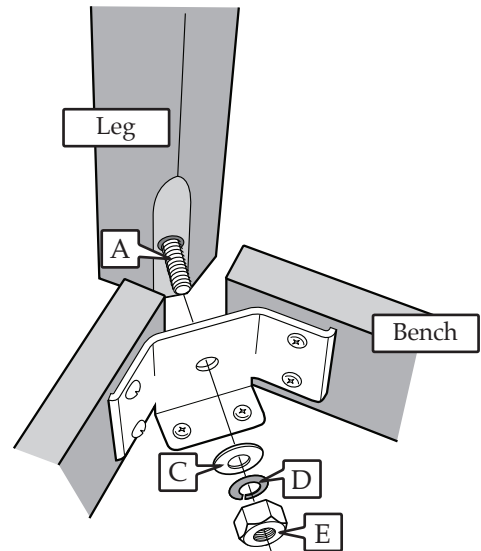

6 Repeat Steps 1-5 to attach remaining three legs.