

e903

Bedienungsanleitung
Instruction Manual
Notice d'emploi
Istruzioni per l'uso
Instrucciones para el uso
Gebruiksaanwijzing

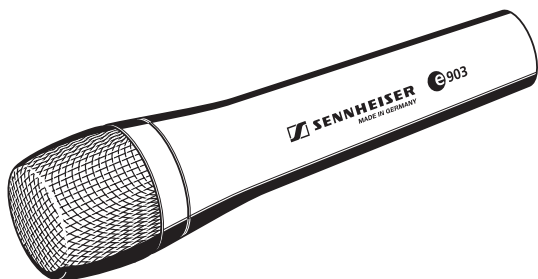

 evolution

| | |
|---------------------------------|----|
| Bedienungsanleitung | 3 |
| Instruction Manual | 7 |
| Notice d'emploi | 11 |
| Istruzioni per l'uso | 15 |
| Instrucciones para el uso | 19 |
| Gebruiksaanwijzing | 23 |

e903

Hochwertiges dynamisches Mikrofon mit Nierencharakteristik. Speziell zur Abnahme von Percussion-Instrumenten und Schlagzeug.

Merkmale

- einzigartige Feedback-Sicherheit
- extrem robust für den rauen Bühnenalltag
- druckvoller, satter Sound bei Instrumenten, Amps etc.
- enorm lebendiger Sound bei Drums und Percussions

Lieferumfang

Mikrofon **e903**

Klammer MZQ 800 Art.-Nr. 4711

Tasche

Bedienungsanleitung

Garantiekarte

Besprechen

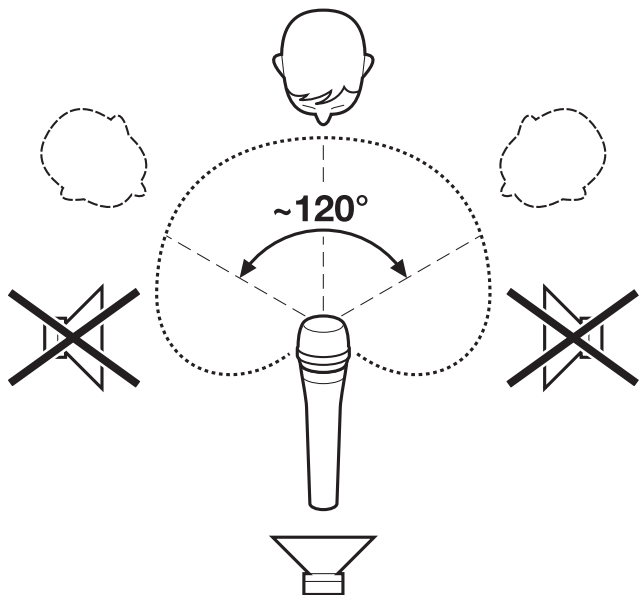

Mikrofonanschluss

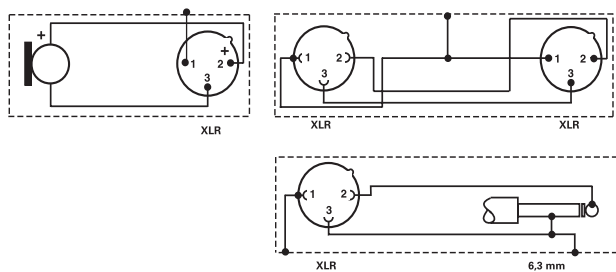
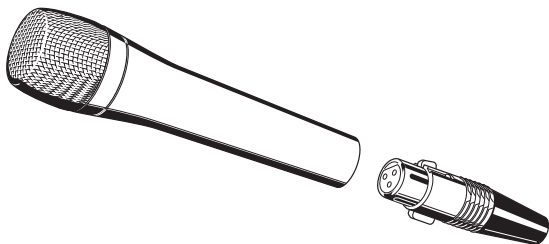

Einsprachekorb abdrehen



Technische Daten

| | |
|---|--------------------------------------|
| Wandlerprinzip | dynamisch |
| Akustische Arbeitsweise | Druckgradientenempfänger |
| Übertragungsbereich | 40–18.000 Hz |
| Richtcharakteristik | Niere |
| Freifeldleerlauf- Übertragungsfaktor (bei 1 kHz) | 2,8 mV/Pa \pm 3 dB |
| Magnetfeldstörfaktor (bei 50 Hz) | $\leq 1\mu\text{V}/\mu\text{T}$ |
| Nennimpedanz (bei 1 kHz) | 350 Ω |
| Min. Abschlussimpedanz | 1 k Ω |
| Rückwärtsdämpfung (bei 1 kHz und 180°) | > 15 dB |
| Stecker | 3-polig XLR-3-Stecker |
| Gewicht | 325 g |
| Maße | \varnothing 40,75 mm, Länge 176 mm |

e903

High-quality dynamic microphone with cardioid pick-up pattern, especially suitable for use with percussion instruments and drums.

Features

- Exceptional feedback rejection
- Extremely rugged for rough stage use
- Rich, powerful sound with instruments, amps, etc.
- Extremely vivid sound with drums and percussions

Delivery includes

e903 microphone

MZQ 800 microphone clamp Cat. No. 4711

Pouch

Instruction manual

Guarantee Certificate

Sound pick-up

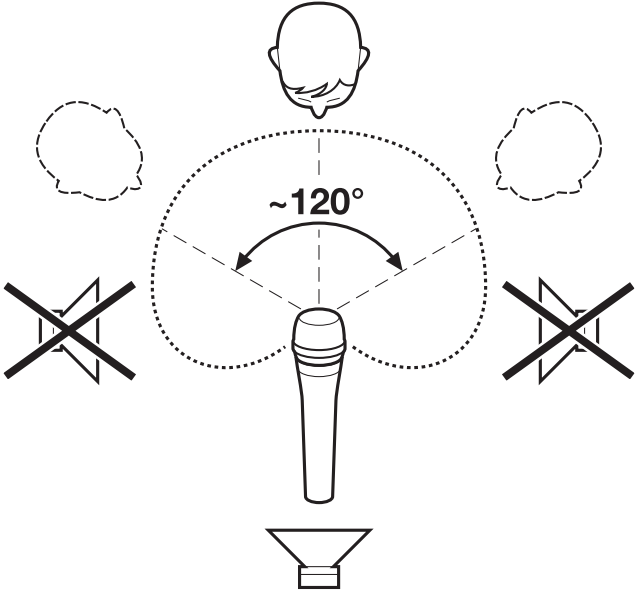

Connection details

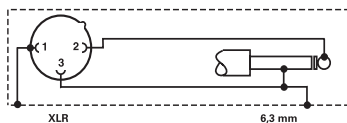
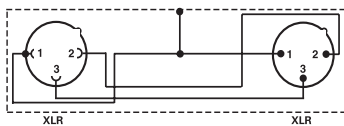
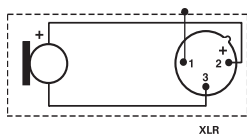
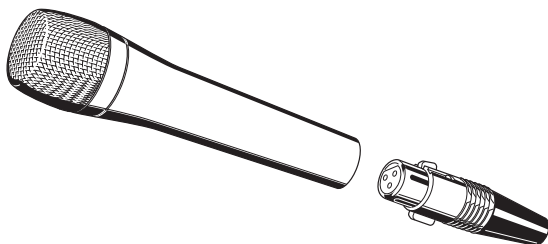

Removing the sound inlet basket



Specifications

| | |
|--|---------------------------------------|
| Transducer principle | dynamic |
| Acoustic operating principle | pressure gradient receiver |
| Frequency response | 40–18,000 Hz |
| Pick-up pattern | cardioid |
| Sensitivity (free field, no load) (at 1 kHz) | 2.8 mV/Pa \pm 3 dB |
| Magnetic field interference factor (at 50 Hz) | $\leq 1\mu\text{V}/\mu\text{T}$ |
| Nominal impedance (at 1 kHz) | 350 Ω |
| Min. terminating impedance | 1 k Ω |
| Front-to-back rejection (at 1 kHz and 180°) | > 15 dB |
| Connector | XLR-3 |
| Weight | 325 g |
| Dimensions | diameter: 40.75 mm, length: 176 mm |

e903

Microphone dynamique de haute qualité, de directivité cardioïde, convenant particulièrement à la batterie et aux instruments à percussion.

Points forts

- Exceptionnelle réjection du Larsen
- Très grande robustesse, pour résister aux rigueurs des concerts
- Son riche et puissant sur les instruments, les amplificateurs, etc.
- Son très vivant sur la batterie et les percussions

L'emballage contient

Microphone **e903**

Pince MZQ 800 N° Réf. 4711

Étui

Notice d'emploi

Document de garantie

Directivité – zone de couverture

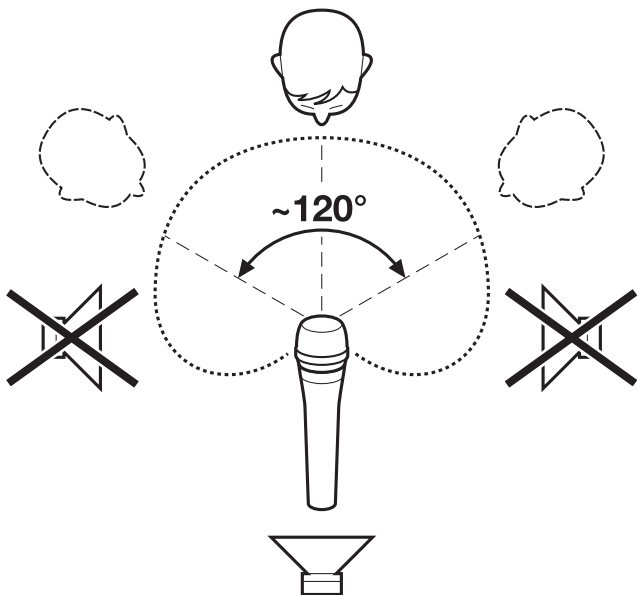

Connexion du microphone

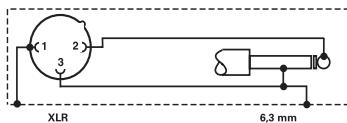
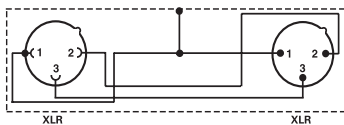
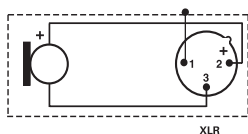
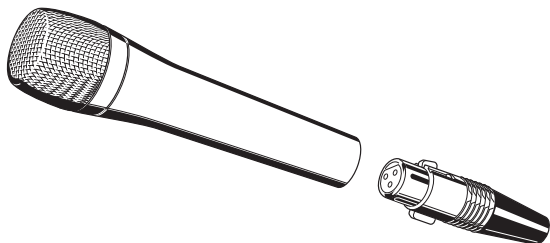

Démontage de la tête de microphone



Caractéristiques techniques

| | |
|--|---|
| Principe transducteur | dynamique |
| Principe acoustique de fonctionnement | gradient de pression |
| Réponse en fréquence | 40–18.000 Hz |
| Directivité | cardioïde |
| Sensibilité (champ libre, à vide) (à 1 kHz) | 2,8 mV/Pa \pm 3 dB |
| Sensibilité aux champs magnétiques (à 50 Hz) | $\leq 1\mu\text{V}/\mu\text{T}$ |
| Impédance nominale (à 1 kHz) | 350 Ω |
| Impédance de charge minimale | 1 k Ω |
| Réjection arrière (à 1 kHz et 180°) | > 15 dB |
| Connecteur | XLR-3, 3 contacts |
| Poids | 325 g |
| Dimensions | diamètre : 40,75 mm, longueur : 176 mm |

e903

Microfono dinamico cardioide di qualità elevata.
Progettato per la registrazione di strumenti a percussione e batteria.

Caratteristiche

- straordinaria protezione contro il feedback
- massima robustezza per il duro lavoro quotidiano sul palco
- suono pieno e potente con strumenti, amplificatori, ecc.
- suono estremamente realistico con batteria e percussioni

Dotazione di fornitura

Microfono **e903**

Dispositivo di fissaggio MZQ 800 N. art. 4711

Custodia

Istruzioni per l'uso

Scheda di garanzia

Raggio di azione

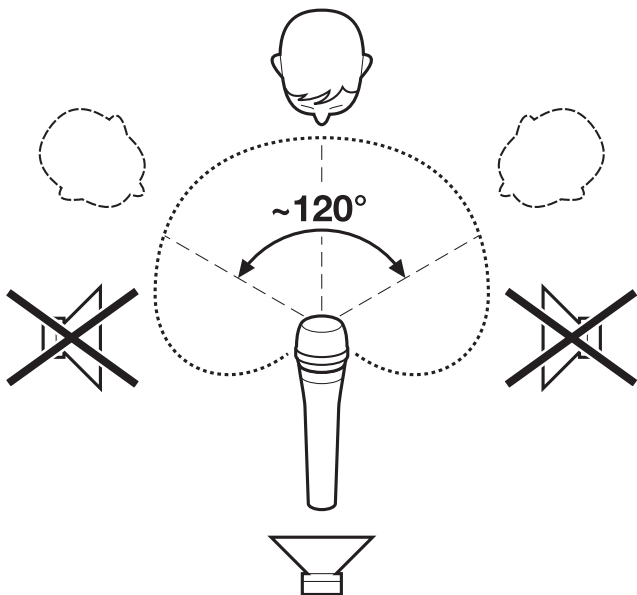

Collegamento del microfono

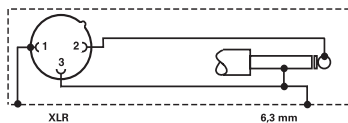
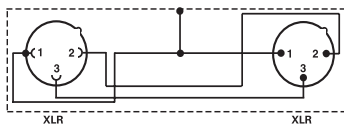
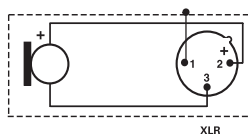
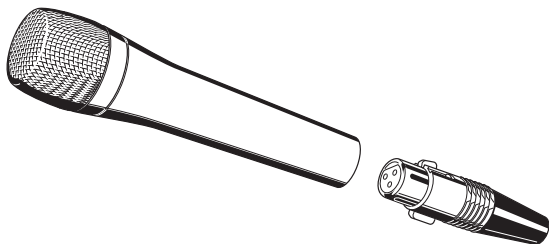

Svitare la testa del microfono



Dati tecnici

| | |
|--|---|
| Principio di funzionamento | dinamico |
| Principio di funzionamento | a gradiente di pressione |
| Risposta in frequenza | 40–18.000 Hz |
| Direttività | cardioide |
| Sensibilità (in campo libero, senza carico) ad 1 kHz | 2,8 mV/Pa \pm 3 dB |
| Sensibilità ai campi magnetici (a 50 Hz) | $\leq 1\mu\text{V}/\mu\text{T}$ |
| Impedenza nominale (ad 1 kHz) | 350 Ω |
| Impedenza minima di carico | 1 k Ω |
| Attenuazione avanti/indietro (ad 1 kHz e 180°) | > 15 dB |
| Connettore | connettore XLR-3 a 3 poli |
| Peso | 325 g |
| Dimensioni | \varnothing 40,75 mm, lunghezza 176 mm |

e903

Micrófono dinámico de alta calidad con característica cardioide. Especial para el registro de instrumentos de percusión y baterías.

Características

- extraordinaria seguridad contra el reacoplamiento
- extremadamente robusto para el uso duro en el escenario
- sonido pleno y saturado en instrumentos, amplificadores, etc.
- sonido enormemente vivo en baterías e instrumentos de percusión

Volumen de suministro

Micrófono **e903**

Pinza MZQ 800 nº art. 4711

Bolsa

Instrucciones para el uso

Tarjeta de garantía

Hablar

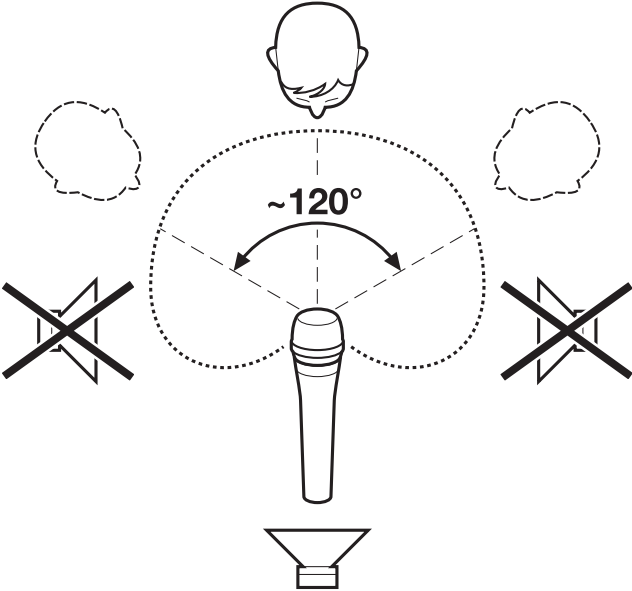

Conexión de micrófono

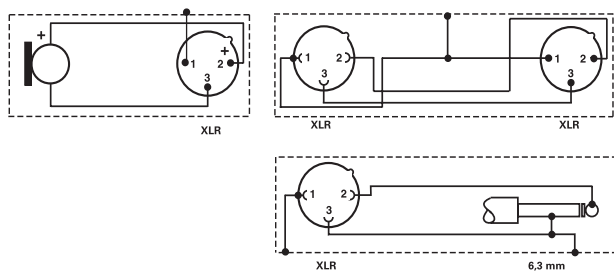
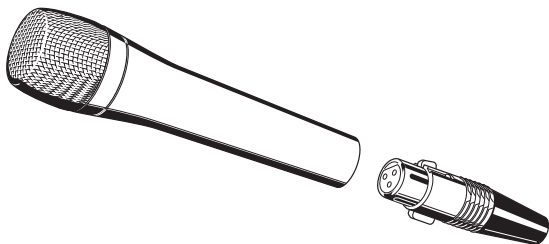

Desmontaje de cesto de registro



Datos técnicos

| | |
|---|--------------------------------------|
| Principio transductor | dinámico |
| Modo acústico | Receptor de gradiente de presión |
| Respuesta | 40–18.000 Hz |
| Característica direccional | cardioide |
| Factor de transmisión neutro en campo libre (con 1 kHz) | 2,8 mV/Pa \pm 3 dB |
| Factor de interferencia de campo magnético (con 50 Hz) | $\leq 1\mu\text{V}/\mu\text{T}$ |
| Impedancia nominal (con 1 kHz) | 350 Ω |
| Impedancia terminal mín. | 1 k Ω |
| Atenuación inversa (con 1 kHz y 180°) | > 15 dB |
| Conector | Conector XLR-3 de 3 polos |
| Peso | 325 g |
| Dimensiones | \varnothing 40,75 mm, largo 176 mm |

903

Hoogwaardige dynamische microfoon met nierkarakteristiek. Speciaal voor de opname van percussie-instrumenten en slagwerk.

Eigenschappen

- unieke feedback-betrouwbaarheid
- extreem robuust t.b.v. de meest zware podiumomstandigheden
- indrukwekkend geluid bij instrumenten, versterkers enz.
- enorm levendig geluid bij drums en percussie-instrumenten

Omvang levering

Microfoon  903

Klem MZQ 800 Art.-Nr. 4711

Hoes

Gebruiksaanwijzing

Garantiebewijs

Vergaderen

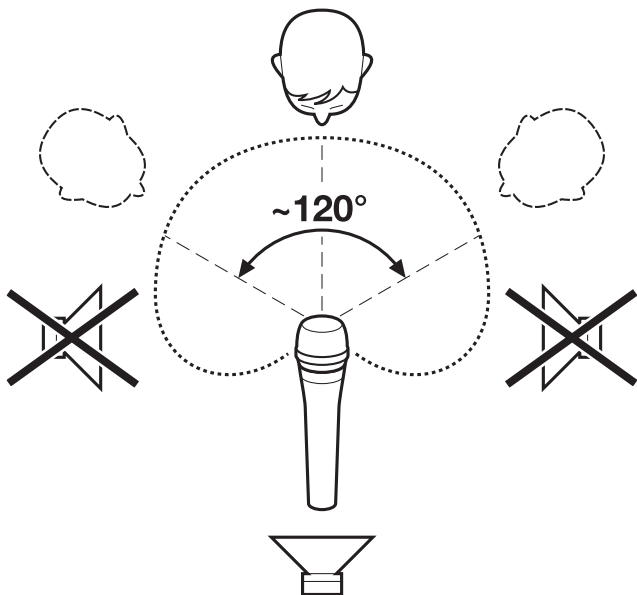

Microfoonaansluiting

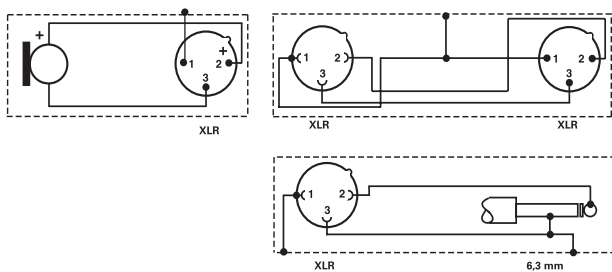
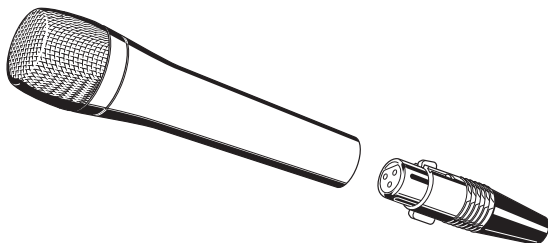

Spreekorf losdraaien



Technische gegevens

| | |
|---|---------------------------------------|
| Omvormerprincipe | dynamisch |
| Akoestische werking | drukgradiënt |
| Frequentiebereik | 40–18.000 Hz |
| Richtkarakteristiek | Nier |
| Onbelaste werking | |
| Frequentiefactor veld (bij 1 kHz) | 2,8 mV/Pa \pm 3 dB |
| Storingsfactor magneetveld (bij 50 Hz) | $\leq 1\mu\text{V}/\mu\text{T}$ |
| Nom. impedantie (bij 1 kHz) | 350 Ω |
| Min. afsluitimpedantie | 1 k Ω |
| Achterwaartse demping (bij 1 kHz en 180°) | > 15 dB |
| Stekker | 3-polige XLR-3-stekker |
| Gewicht | 325 g |
| Afmeting | \varnothing 40,75 mm, lengte 176 mm |

Soll-Frequenzgang
 Nominal Frequency response
 Courbe de réponse
 Risposta armonica nominale
 Respuesta nominal
 Streefwaarde-Frequentiearakteristiek

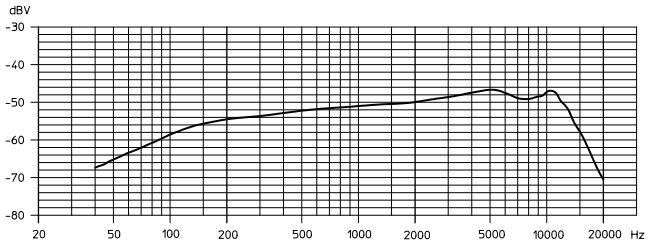

Polardiagramm
 Pick-up pattern
 Diagramme de la directivité
 Diagramma polare
 Diagrama de la directividad
 Polardiagram

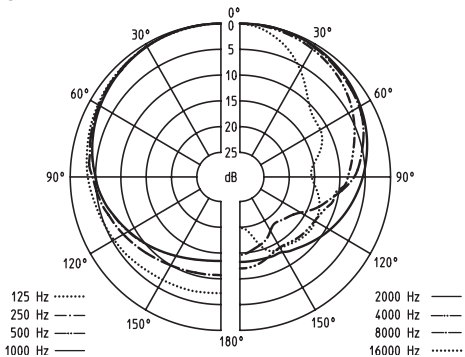



Konformitätserklärung

Sennheiser electronic GmbH & Co. KG erklären, dass dieses Gerät die anwendbaren CE-Normen und Vorschriften erfüllt.

Approval

Sennheiser electronic GmbH & Co. KG declare that this device is in compliance with the applicable CE standards and regulations.

Certification

Sennheiser electronic GmbH & Co. KG déclarons que cet appareil est en conformité avec les normes CE.

Certificazione

Sennheiser electronic GmbH & Co. KG dichiara che questo apparecchio risponde alle normative e alle prescrizioni CE applicabili.

Autorizacion

Sennheiser electronic GmbH & Co. KG declara que este aparato cumple las normas y directrices de la CE aplicables.

Vergunning

Sennheiser electronic GmbH & Co. KG verklaren, dat dit toestel voldoet aan de toepasselijke CE-normen en voorschriften.

Diese Service-Nummer gilt nur für Deutschland



K.I.S.S.

Kunden-Informationssystem-Sennheiser

0180 / 5221 539

0,12 € je Minute

Montag -Freitag: 8.00 Uhr - 18.00 Uhr

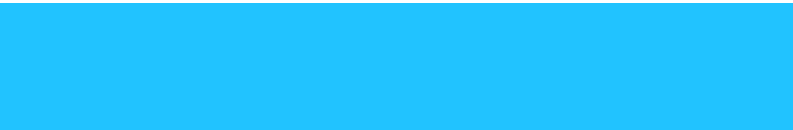

Sennheiser electronic GmbH & Co. KG

D-30900 Wedemark

Fon +49 +5130/600 0

Fax +49 +5130/600 300

www.sennheiser.com

Printed in Germany

Publ. 03/03

89057/A01