



PIAGGIO®

WORKSHOP MANUAL

633112



Liberty 50 Catalyzed



WORKSHOP MANUAL

Liberty 50 Catalyzed

The descriptions and illustrations supplied in this publication are not binding. PIAGGIO therefore reserves the right to make any changes to pieces, parts or accessory supplies, which it believes to be appropriate for improvement purposes or any requirement of a constructive or commercial nature, at any time, without the obligation to up-dating this publication before time, the essential characteristics of the type described and illustrated here remaining valid.

Not all versions reported in this publication are available in all Countries. The availability of single versions should be checked at the official Piaggio sales network.

"© Copyright 2003 - PIAGGIO & C. S.p.A. Pontedera. All rights reserved. No part of this publication may be reproduced."

PIAGGIO & C. S.p.A. - After Sales Service

www.piaggio.com

V.le R. Piaggio, 23 - 56025 PONTEDERA (Pi)

WORKSHOP MANUAL

Liberty 50 Catalyzed

This workshop manual has been drawn up by Piaggio & C. Spa to be used by the workshops of Piaggio-Gilera dealers. This manual is addressed to Piaggio service mechanics who are supposed to have a basic knowledge of mechanics principles and of vehicle fixing techniques and procedures. Any important changes made to the vehicles or to specific fixing operations will be promptly reported by updates to this manual. Nevertheless, no fixing work can be satisfactory if the necessary equipment and tools are unavailable. It is therefore advisable to read the sections of this manual relating to specific tools, along with the specific tool catalogue.

N.B. Provides key information to make the procedure easier to understand and carry out.

CAUTION Refers to specific procedures to carry out for preventing damages to the vehicle.

WARNING Refers to specific procedures to carry out to prevent injuries to the repairer.



Personal safety Failure to completely observe these instructions will result in serious risk of personal injury.



Safeguarding the environment Sections marked with this symbol indicate the correct use of the vehicle to prevent damaging the environment.



Vehicle intactness The incomplete or non-observance of these regulations leads to the risk of serious damage to the vehicle and sometimes even the invalidity of the guarantee.



INDEX OF TOPICS

CHARACTERISTICS	CAR
TOOLING	ATT
MAINTENANCE	MAN
TROUBLESHOOTING	RIC GUA
ELECTRICAL SYSTEM	IMP ELE
ENGINE FROM VEHICLE	MOT VE
ENGINE	MOT
SUSPENSIONS	SOSP
BRAKING SYSTEM	IMP FRE
CHASSIS	CARROZ
PRE-DELIVERY	PRECON
TIME	TEMP

INDEX OF TOPICS

CHARACTERISTICS

CAR

Rules

This section describes general safety rules for any interventions to be performed on the vehicle.

Safety rules

- Should it be necessary to keep the engine running while servicing, make sure that the area or room is well ventilated, and use special exhaust fans, if required. Never let the engine running in closed rooms. In fact, exhaust gases are toxic.
 - The battery electrolyte contains sulphuric acid. Protect your eyes, cloths and skin. Sulphuric acid is highly corrosive; in the event of contact with your eyes or clothes, rinse thoroughly with water and consult a doctor immediately.
 - The battery produces hydrogen, a gas that can be highly explosive. Do not smoke and avoid sparks and flames when close to the battery, especially during recharge.
 - Fuel is highly flammable, and in some conditions it can be explosive. Do not smoke in the working area, and avoid free flames or sparks.
 - Clean the brake pads in a well ventilated environment, directing the compressed air jet so as to not intake the dust produced by the wear of the friction material. Even though the latter contains no asbestos, dust inhalation is harmful.
-

Safety rules

- Use original PIAGGIO spare parts and lubricants recommended by the Manufacturer. Non-original or non-conforming spares may damage the vehicle.
 - Use only the specific tools designed for this vehicle.
 - Always use new gaskets, sealing rings and split pins upon reassembly.
 - After removal, clean the components using non-flammable or low fire-point solvent. Lubricate all working surfaces before reassembly, except for conical couplings.
 - After reassembly, check that all components have been installed properly and that they are in good working order.
 - For removal, overhaul and reassembly operations use only tools provided with metric measures. Metric bolts, nuts and screws are not interchangeable with coupling members with English measurement. Using improper coupling members and tools may impair the vehicle.
 - Should any interventions to the vehicle electric system be required, check that the electrical connections - especially earth and battery connections - have been implemented properly.
-

Vehicle identification

FRAME/ENGINE PREFIX

Specification	Desc./Quantity
Frame prefix	ZAPC42100÷1001
Engine prefix	C421M÷1001

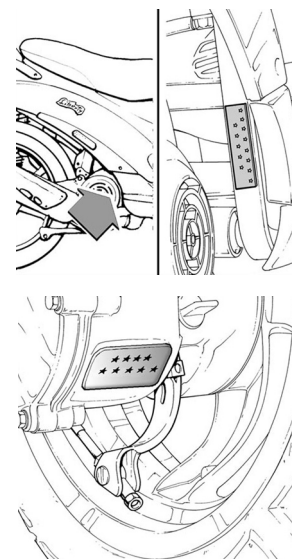

Dimensions and mass

WEIGHT AND DIMENSIONS

Specification	Desc./Quantity
Dry weight	88 Kg
Width	670 mm
Length	1.930 mm
Wheel base	1.330 mm
Seat height	775 mm.

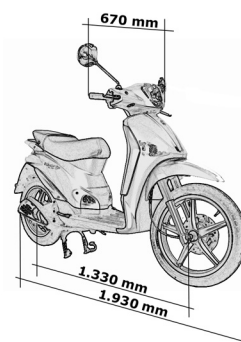

Engine

ENGINE

Specification	Desc./Quantity
Engine type	Piaggio Hi-PER2, 2-stroke, single-cylinder
Bore x stroke	40 x 39,3 mm
Displacement	49,40 cm ³
Compression ratio	10,3 :1
Carburettor	DELLORTO PHVA 17,5
CO adjustment	3,5% ± 0,5
Engine idle	1800 ÷ 2000 g/min.
Air filter	Sponge, impregnated with mixture (50% Selenia Air Filter Oil and 50% lead-free fuel).
Starter system	starter motor/kick-start.
Lubrication	Guaranteed by oil from fuel-oil mixture and varied

Specification	Desc./Quantity
	with engine speed and throttle opening through a pump driven by the crankshaft via toothed belt.
Fuel system	Gravity, unleaded petrol (minimum octane number 95), through carburettor.
Cooling system	forced air

Transmission

TRASMISSIONS

Specification	Desc./Quantity
Transmission	Expanding pulley type automatic speed variator with vee belt, automatic clutch and gear final drive.

Capacities

CAPACITY

Specification	Desc./Quantity
Rear hub oil	Quantity : ~ 85 cc
Mixer oil	1.2 litres
Fuel tank	6 litres (including 1-litre reserve)

Electrical system

ELECTRICAL COMPONENTS

Specification	Desc./Quantity
Ignition type	capacitive discharge electronic ignition with incorporated high-voltage coil.
Ignition advance variable, with microprocessor (before T.D.C.)	Fixed $17^{\circ} \pm 1$
Reccomended spark plug	CHAMPION RGN2C
Battery	12V-4Ah
Main fuse	7,5 A
Generator	In alternate current with three-second output

Frame and suspensions

FRAME AND SUSPENSION

Specification	Desc./Quantity
Type	Welded steel pipes with pressed sheet metal stiffening
Front suspension	mechanical telescopic steering tube
Front suspension stroke	66,8 mm
Trail	100 mm
Rear suspension	Single double-acting hydraulic shock absorber with coaxial spiral spring. Engine-frame mount by swinging arm.
Rear suspension bump position	70 mm

Brakes

BRAKE

Specification	Desc./Quantity
Front brake	220 mm disc brake with hydraulic linkage (r.h. brake lever).
Rear brake	drum brake (Ø 140 mm) with mechanical linkage.(l.h. brake lever).

Wheels and tyres

WHEELS AND TYRES

Specification	Desc./Quantity
Front tyre	Tubeless 90/80-16"
Front wheel rim	Die-cast aluminium alloy 2.15 x16"
Rear tyre	Tubeless 110/80-14"
Rear wheel rim	Die-cast aluminium alloy 2.75 x14"
Tyre pressure (front wheel)	2 bar
Tyre pressure (rear wheel)	2,2 bar
Tyre pressure (rear wheel driver and luggage)	2,5 bar

N.B.

**CHECK AND ADJUST TYRE PRESSURE WITH TYRES AT AMBIENT TEMPERATURE.
ADJUST PRESSURE ACCORDING TO THE WEIGHT OF THE RIDER AND ACCESSORIES.**

Secondary air

In order to clean the sponge filters of the secondary air system, please proceed as follows:

- 1) Remove the plastic cap (1) from the transmission cover by inserting a small screwdriver through one of the three slits and pressing against the retaining spline, to release it.
- 2) Wash the polyurethane sponge filter with soap and water, then dry it with compressed air and re-locate it in its housing. Refit the intake cover minding the angle reference.
- 3) Loosen the two screws (2) fixing the SAS aluminium cover in order to reach the polyurethane sponge located inside the box; clean the sponge as indicated in 2) and refit each component, after having in the meantime ensured that the steel plate is not deformed or unable to guarantee a perfect sealing when shut; replace if necessary.

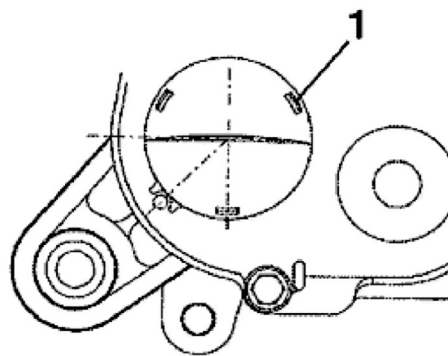

N.B.

WHEN REFITTING THE VALVE COMPONENTS, ENSURE TO CORRECTLY PLACE THE STEEL LATH IN THE HOUSING MACHINED ON THE PLASTIC AND ALUMINIUM COVERS.

CAUTION

DURING THE OPERATION 3) ALWAYS CHECK THE LEAK TIGHTNESS OF THE TWO RUBBER SLEEVES (3) LOCATED AT THE END OF THE SECONDARY AIR DUCT; REPLACE IF NECESSARY; USE NEW ZIP TIES.

Carburettor

50cc Version

Dell'Orto

DELLORTO CARBURETTOR

Specification	Desc./Quantity
Type	PHVA 17,5 RD
Choke diameter	Ø 17,5
Adjustments reference number	8423

Specification	Desc./Quantity
Maximum thrust:	53
Maximum air thrust (on body):	Ø1,5
Tapered pin stamping:	A22
Needle position (notches from top):	1
Jet mixer:	209 HA
Minimum thrust:	32
Minimum air thrust (on body):	Free
Initial minimum mixture screw opening:	1 1/2
Starter jet	50
Starter air thrust (on body)	Ø 1,5
Starter pin stroke	11 mm
Choke maximum cone	Ø 1,5

Overhaul data

Assembly clearances

Cylinder - piston assy.

CONNECTION PISTON AND CYLINDER

Name	Play	Initials	Cylinder	Piston	Play on fitting
Cylinder	Ø 40+0,033+0,00 5	M	40,005 - 40,012	39,943 - 39,95	0,055 - 0,069
Cylinder	Ø 40+0,033+0,00 5	N	40,012 - 40,019	39,95 - 39,957	0,055 - 0,069
Piston	Ø 40-0,029-0,057	O	40,019 - 40,026	39,957 - 39,964	0,055 - 0,069
Piston	Ø 40-0,029-0,057	P	40,026 - 40,033	39,964 - 39,971	0,055 - 0,069
Cylinder first uprat	Ø 40+0,033+0,00 5	M1	40,205 - 40,212	40,143 - 40,15	0,055 - 0,069
Cylinder first uprat	Ø 40+0,033+0,00 5	N1	40,212 - 40,219	40,15 - 40,157	0,055 - 0,069
Piston first up-	Ø	O1	40,219 -	40,157 -	0,055 - 0,069

Name	Play	Initials	Cylinder	Piston	Play on fitting
rat.	40-0,029-0,057		40,226	40,164	
Piston first up- rat.	\emptyset 40-0,029-0,057	P1	40,226 - 40,233	40,164 - 40,171	0,055 - 0,069
Cylinder second uprat.	\emptyset 40+0,033+0,00 5	M2	40,405 - 40,412	40,343 - 40,35	0,055 - 0,069
Cylinder second uprat.	\emptyset 40+0,033+0,00 5	N2	40,412 - 40,419	40,35 - 40,357	0,055 - 0,069
Piston second uprat.	\emptyset 40-0,029-0,057	O2	40,419 - 40,426	40,357 - 40,364	0,055 - 0,069
Piston second uprat.	\emptyset 40-0,029-0,057	P2	40,426 - 40,433	40,364 - 40,371	0,055 - 0,069

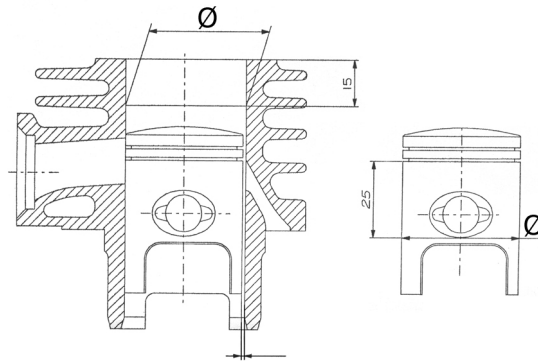

Piston rings

UPRATING TABLE

Name	Dimensions	Initials	Quantity
Compression lining	40	A	0,10 ÷ 0,25
Compression lining 1° greater	40,2	A	0,10 ÷ 0,25
Compression lining 2° greater	40,4	A	0,10 ÷ 0,25

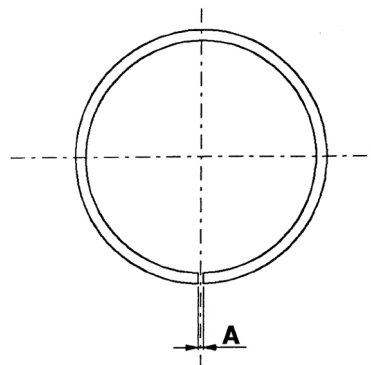

Crankcase - crankshaft - connecting rod

END PLAY BETWEEN DRIVING SHAFT AND CONNECTING ROD

Name	Dimensions	Initials	Quantity
Connecting rod	11,750-0,05	A	E = 0,25 ÷ 0,50
Packing washer	0,5 ± 0,03	G	E = 0,25 ÷ 0,50
Half shaft transmission side	13,75+0,040	C	E = 0,25 ÷ 0,50
Half shaft flywheel side	13,75+0,040	D	E = 0,25 ÷ 0,50
Spacing tool	40,64	H	E = 0,25 ÷ 0,50
Cage	11,80-0,35	B	F = 0,20 ÷ 0,75
Packing washer	0,5 ± 0,03	G	F = 0,20 ÷ 0,75
Half shaft transmission side	13,75+0,040	C	F = 0,20 ÷ 0,75
Half shaft flywheel side	13,75+0,040	D	F = 0,20 ÷ 0,75
Spacing tool	40,64	H	F = 0,20 ÷ 0,75

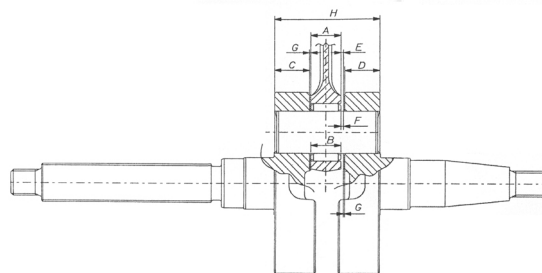

Slot packing system

- Fit the cylinder without positioning the base gasket
- Position a dial gauge on the special tool and zero it on rectified surface.
- Fix the tool on the top of the cylinder using two nuts to fix it to the studs and then bring the piston to T.D.C.
- The gasket thickness to be adopted varies with the measurement. For this reason gaskets with three different thicknesses are available as

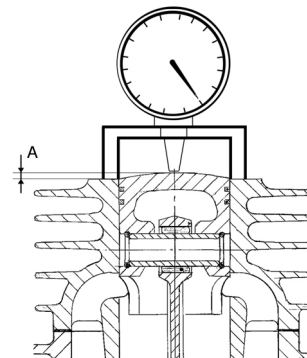

spares.

Specific tooling

020272Y Tool for checking the position of the piston

PACKING SYSTEM

Name	Measure A	Thickness
Packing	2,80 ÷ 3,04	0,4
Packing	3,04 ÷ 3,24	0,6
Packing	3,25 ÷ 3,48	0,8

Products

TABLE OF RECOMMENDED PRODUCTS

Product	Description	Specifications
TUTELA ZC 90	Rear hub oil	SAE 80W/90 Oil that passes API GL3 specifications
SELENIA HI Scooter 2 Tech	Oil for flexible transmission lubrication (acceleration control, mixer and km counter)	Oil for two-stroke motors
SELENIA Air Filter Oil	Oil for air filter sponge	Mineral oil with specific additive for increasing the ISO VG 150
SYSTEM TW 249 AREXONS	Grease (brake/acceleration command levers)	Compound calcium soap grease NGLI 1-2
SELENIA HI Scooter 2 Tech	Mixer Oil	Synthetic oil that passes API TC ++ specifications
TUTELA TOP 4	Brake fluid	Synthetic fluid SAE J1703, NHTSA 116 DOT 4, ISO 4925
MONTBLANC MOLYBDENUM GREASE	Grease for driven pulley shaft compensating ring and mobile driven pulley sliding seat	Molybdenum bisulphide grease
TUTELA ZETA 2	Grease for steering, seats of pin and swing arm	Lithium soap and zinc oxide grease NLG12
TUTELA MRM2	Grease for driven pulley bushing and mobile driven pulley seat	Bisulphide soap grease with Molybdenum NLGI2

INDEX OF TOPICS

TOOLING

ATT

TOOLS

Stores code	Description
001330Y	Steering seat installer, to be fitted with parts: 001330Y009-For lower seat, 001330Y013-For upper seat
001467Y006	20-mm pliers
001467Y007	Bell for bearings external Ø 54 mm
001467Y009	Bell for bearings external Ø 50 mm
001467Y013	15-mm pliers
001467Y014	15 mm pliers
001467Y017	Bell for bearings external Ø 39 mm
001467y021	11 mm bearing clip
002465Y	Pliers for snap rings
006029y	Drift for fitting thrust ring seats on steering tube
020004Y	Drift for removing thrust rings from steering head tube
020055Y	Steering tube ring nut spanner
020150Y	Support for air heater "METABO HG 1500/2"
020151Y	Air heater "METABO HG 1500/2"
020162y	Flywheel extractor
020163y	Crankcase splitting plate
020164y	Half-pulleys fixing sheath
020165y	Starter sprocket retainer
020166y	Piston rings fixing tool
020261Y	Kick-starter spring assembler
020262Y	Crankcase detachment plate
020265y	Bearing fitting stand
020325y	Pliers for brake-shoe springs
020329Y	Pump MITYVAC
020330Y	Stroboscopic gun for two- and four-stroke engines
020331Y	Digital multimeter
020332Y	Digital rpm counter
020333Y	Single battery charger
020334Y	Multiple battery charger
020335Y	Magnetic stand and comparator
020350y	Electric system diagnostic device

Stores code	Description
020357Y	32 x 35 mm adaptor
020359Y	42 x 47 mm hub bearing fitting adaptor
020376Y	Handle for punches
020412Y	15 mm guide
020456Y	Ø 24 mm adaptor
020483Y	30 mm guide
020487Y	Fork oil seal removing tool
020565Y	Compass flywheel stop spanner
494929	Exhaust gas analyser

INDEX OF TOPICS

MAINTENANCE

MAN

Maintenance chart

EVERY 2 YEARS

Action

Brake fluid - Change

AT 1000 KM OR 4 MONTHS

Action

Hub Oil - Replacement

Oil mixer/throttle linkage - Adjust

Speedometer cable - Grease

Steering - Adjust

Brake levers - Grease

Brake fluid level - Check

Nuts, bolts and fasteners - Check

Electrical system and battery - Check

Tires-inflation and wear - Check

Vehicle and brake test - Road test

AT 5000 KM OR 12 MONTHS, 25000 KM, 35000 KM AND 55000 KM

Action

Hub oil level - Check

Spark plug/Electrode gap - Change

Air filter - cleaning

Oil mixer/throttle linkage - Adjust

Brake levers - Grease

Brake pads - Check condition + wear

Brake fluid level - Check

Electrical system and battery - Check

Tires-inflation and wear - Check

Vehicle and brake test - Road test

AT 10000 KM OR 24 MONTHS AND 50000 KM

Action

Hub Oil - Replacement

Spark plug/spark gap - replacement

Air filter - cleaning

Idle speed/Fuel (*) - Adjust

Action

Oil mixer/throttle linkage - Adjust

Variator rollers - Change

Speedometer cable - Grease

Transmission Belt - Check

Steering - Adjust

Brake levers - Grease

Brake pads - Check condition + wear

Brake fluid level - Check

Transmissions - Lubricate

Nuts, bolts and fasteners - Check

Suspensions - Check

Electrical system and battery - Check

Headlight - Adjust

Tires-inflation and wear - Check

Vehicle and brake test - Road test

(*) See CO regulation in the «Adjusting the engine idle» section

AT 15000 KM AND 45000 KM

Action

Hub oil level - Check

Spark plug/spark gap - replacement

Air filter on carburetor - Clean

Oil mixer/throttle linkage - Adjust

Transmission Belt - Replacemen

Brake levers - Grease

Brake pads - Check condition + wear

Brake fluid level - Check

Electrical system and battery - Check

Tires-inflation and wear - Check

Vehicle and brake test - Road test

SAS box (sponge) (**) - Clean

SAS suction cap (sponge) (**) - Clean

(**) See rules in the «Secondary Air System» section

AT 20000 KM AND 40000 KM

Action

Hub Oil - Replacement

Spark plug/Electrode gap - Change

Air filter - cleaning

Idle speed/Fuel (*) - Adjust

Cylinder cooling system - Check/Clean

Oil mixer/throttle linkage - Adjust

Transmission Belt - Check

Variator rollers - Change

Fule-oil mixer belt - Change

Speedometer cable - Grease

Steering - Adjust

Brake levers - Grease

Brake pads - Check condition + wear

Brake fluid level - Check

Transmissions - Lubricate

Nuts, bolts and fasteners - Check

Suspensions - Check

Electrical system and battery - Check

Headlight - Adjust

Tires-inflation and wear - Check

Vehicle and brake test - Road test

(*) See CO regulation in the «Adjusting the engine idle» section

At 30000 Km

Action

Hub Oil - Replacement

Spark plug/spark gap - replacement

Air filter - cleaning

Idle speed/Fuel (*) - Adjust

Oil mixer/throttle linkage - Adjust

Transmission Belt - Check

Transmission Belt - Replacemen

Variator rollers - Change

Speedometer cable - Grease

Steering - Adjust

Action

Brake levers - Grease

Brake pads - Check condition + wear

Braking circuit hose - Replacement

Brake fluid level - Check

Transmissions - Lubricate

Nuts, bolts and fasteners - Check

Suspensions - Check

Electrical system and battery - Check

Headlight - Adjust

Tires-inflation and wear - Check

Vehicle and brake test - Road test

SAS box (sponge) (**) - Clean

SAS suction cap (sponge) (**) - Clean

(*) See CO regulation in the «Adjusting the engine idle» section (**) See rules in the «Secondary Air System» section

AT 60000 KM

Action

Hub Oil - Replacement

Spark plug/spark gap - replacement

Air filter - cleaning

Idle speed/Fuel (*) - Adjust

Cylinder cooling system - Check/Clean

Oil mixer/throttle linkage - Adjust

Transmission Belt - Check

Transmission Belt - Replacemen

Variator rollers - Change

Fule-oil mixer belt - Change

Speedometer cable - Grease

Steering - Adjust

Brake levers - Grease

Brake pads - Check condition + wear

Braking circuit hose - Replacement

Brake fluid level - Check

Transmissions - Lubricate

Nuts, bolts and fasteners - Check

Action

Suspensions - Check

Electrical system and battery - Check

Headlight - Adjust

Tires-inflation and wear - Check

Vehicle and brake test - Road test

SAS box (sponge) (**) - Clean

SAS suction cap (sponge) (**) - Clean

(*) See CO regulation in the «Adjusting the engine idle» section (**) See rules in the «Secondary Air System» section

Carburettor

Disassemble all carburettor components, accurately wash them in solvent, then dry them with compressed air. To ensure thorough cleaning, pay special attention to the passages in the carburettor body.

- Carefully check the condition of all components.
- The **throttle** must slide freely in the chamber, if the play is excessive because of wear, replace the throttle.
- Replace the carburettor if the chamber shows signs of wear as to prejudice the valve's regular seal or free sliding (though it is new).
- When reassembling the carburettor, it is a good rule to replace the gaskets.

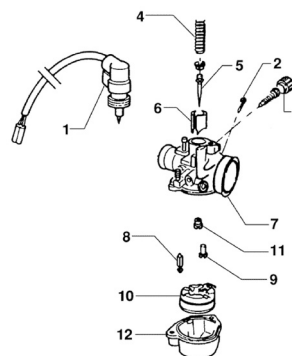
WARNING

PETROL IS HIGHLY EXPLOSIVE. ALWAYS FIT NEW SEALS AND GASKETS TO PREVENT LEAKAGE.

1. Automatic choke device - 2. Idle air adjusting screw - 3. Idle adjusting screw - 4. Throttle valve spring - 5. Conical needle - 6. Throttle valve - 7. Carburettor body - 8. Needle - 9. Idle jet - 10. Float - 11. Main jet - 12. Float bowl.
-

Checking the spark advance

- The check must be carried out at over 4,000 rpm with a strobe light. The spark advance must be 17° before the T.D.C.
- This value is correct when the reference mark shown on the flywheel cover is aligned with that machined on the cooling fan and the phase-shifter on the strobe light is set onto 17°.



N.B.

IN THE EVENT OF IRREGULAR OPERATION, PERFORM THE CHECKS LISTED IN THE ELECTRICAL CIRCUIT CHAPTER.

CAUTION

BEFORE PERFORMING THE ABOVE MENTIONED INSPECTIONS, CHECK THE FLYWHEEL IS CORRECTLY KEYED ONTO THE CRANKSHAFT

Specific tooling

020330Y Stroboscopic gun for two- and four-stroke engines

Spark plug

- Rest the vehicle on its centre-stand;
- Remove the central flap, shown in the figure, by loosening the two fixing screws;
- Detach the H.T. cable cap from the spark plug;
- Remove the spark plug using the supplied box spanner;
- Examine the spark plug conditions, the insulator integrity, and measure the spark gap using a suitable feeler gauge;
- Proceed by adjusting the spark gap by carefully bending the outer electrode.

If defective, replace the spark plug with new of the prescribed model;

- Insert the spark plug in with the correct inclination, screwing it in by hand, hence tighten it using

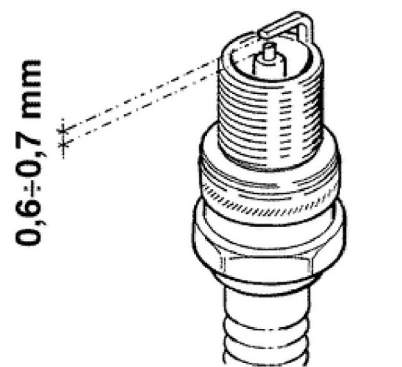

the supplied box

-spanner at the prescribed torque; -Reattach the spark plug cap; -Refit the central flap.

CAUTION

THE SPARK PLUG REMOVAL MUST BE CARRIED OUT WITH THE ENGINE COLD. THE SPARK PLUG MUST BE REPLACED EVERY 5,000 KM. THE USE OF NON APPROVED ELECTRONIC IGNITION DEVICES OR SPARK PLUGS OTHER THAN THE PRESCRIBED MODEL MAY SERIOUSLY DAMAGE THE ENGINE.

Characteristic

Recommened spark plug

CHAMPION RGN2C

Electric characteristic

Electrode gap

0,6 ÷ 0,7 mm.

Locking torques (N*m)

Spark plung 25 - 30 Nm

Hub oil

Check

A new hub oil dipstick (item no. 832019) has been introduced. This dipstick differs from the previous one in that it is 5 mm longer and has a cube on the lower end with a dot at the centre of two of its four side faces. Such dot is the reference for the engine oil level check on the Beverly; (see figure).



To check the correct oil level, proceed as follows:

- 1) Place the vehicle on the stand on level ground.
- 2) Unscrew oil dipstick «A», wipe it with a clean rag, reinsert it and screw it in fully.
- 3) Pull out the dipstick and check that the oil level

is in the middle (two-notch dipstick) or reaches the middle notch (three-notch dipstick).

4) Reinsert the dipstick and screw it in fully.

Recommended products

TUTELA ZC 90 Rear hub oil

SAE 80W/90 Oil that passes API GL3 specifications

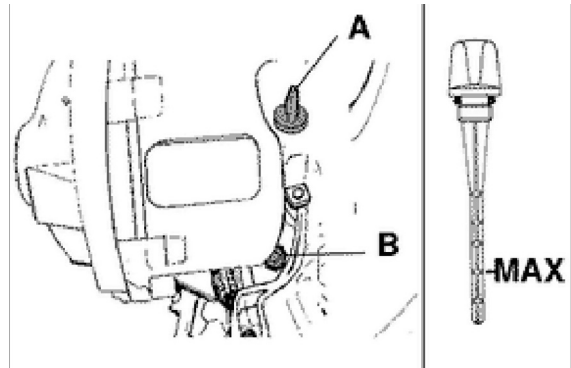

Replacement

- Remove the oil filler cap «A».
- Loosen the oil draining cap «B» and let the oil completely drain the tank.
- Tighten the draining cap and refill the hub with oil (approx. 75 cc).

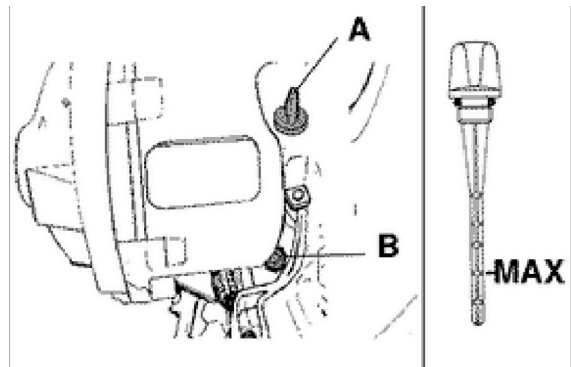

Air filter

- Remove the cleaner plug by unloosing the 6 fixing screws. Remove the filtering element.

Cleaning:

- Wash with water and neutral soap.
- Dry with a clean cloth and small jets of compressed air.
- Soak with a 50% fuel/oil mixture.
- Let the filtering element drain and then squeeze it with your hands without crushing it.
- Let it dry and refit it. Mineral oil with special additives to increase its adhesiveness ISO VG 150

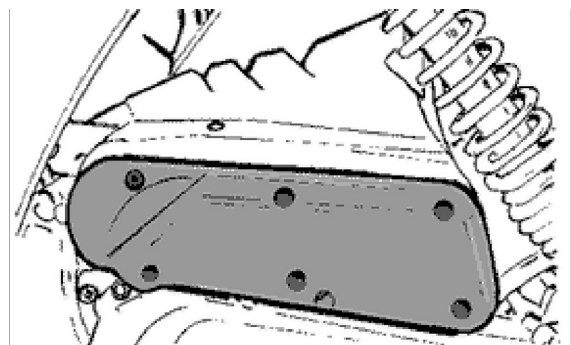

CAUTION

NEVER RUN THE ENGINE WITHOUT THE AIR FILTER, THIS WOULD RESULT IN AN EXCESSIVE WEAT OF THE PISTON AND CYLINDER

Recommended products

Selenia Air Filter Oil Air filter sponge oil

Mineral oil with specific additives to increase adhesion ISO VG 150

Checking the ignition timing

-Adjust the control cables:

Mixer cable: see "Mixer timing" procedure, below.

Throttle cable: adjust the screw on the carburettor so that there is no play on the sheath.

Splitter control cable: adjust the screw on the throttle grip on the handlebar so that there is no play on the twist grip.

All cables must be adjusted so that there is no play on their sheaths.

Mixer timing

- Adjust via the transmission screw on the crankcase, with the throttle cable released, the reference machined on the rotating plate which must be aligned to that shown on the mixer body as indicated in the figure. While performing this operation the engine must be fed with a 2% oil-fuel mixture (at least 0.5 litres if the tank is empty).

CAUTION

WHEN RUNNING OUT OF OIL OR REMOVING THE OIL TANK, FOLLOW THE MIXER BLEEDING OPERATIONS AS FOLLOWS: REFILL THE OIL TANK, WITH THE MIXER FITTED ONTO THE ENGINE, AND THE ENGINE NOT RUNNING, DETACH THE MIXER TUBE FROM THE CARBURETTOR AND LOOSEN THE BLEED SCREW (SEE ARROW IN FIGURE) UNTIL OIL STARTS FLOWING OUTWARDS. RECONNECT THE INLET TUBE TO THE CARBURETTOR, FIXING IT WITH THE APPROPRIATE METALLIC CLAMP.

Recommended products

SELENIA HI Scooter 2 Tech Mixer Oil

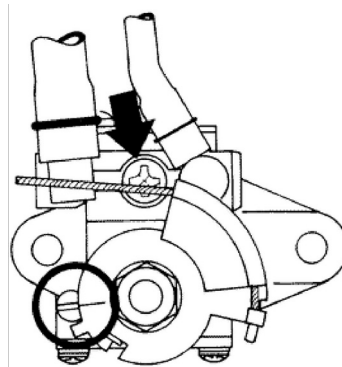

Synthetic oil that passes API TC ++ specifications

Braking system

Level check

Proceed as follows:

- Rest the vehicle onto its centre-stand and align the handlebars;
- Check the liquid level through the inspection hole «A».

A certain decrease in the liquid level is due to the wear of the pads.

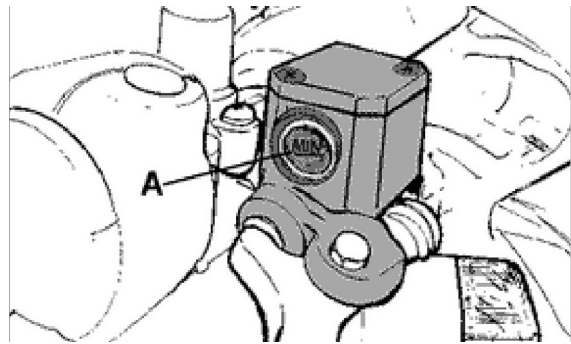

Top-up

Use the following procedure:

Loosen the two screws, remove the reservoir cap, remove the gasket and top up only with the prescribed fluid without exceeding the maximum level.

CAUTION

BRAKE FLUID TYPE TUTELA TOP 4

CAUTION

KEEP THE BRAKE FLUID AWAY FROM THE SKIN, THE EYES AND CLOTHING. IN CASE OF CONTACT, RINSE GENEROUSLY WITH WATER.

CAUTION

THE BRAKE FLUID IS HIGHLY CORROSIVE. TAKE CARE NOT TO SPILL IT ON THE PAINTWORK.

CAUTION

THE BRAKE FLUID IS HYGROSCOPIC, I.E. IT ABSORBS HUMIDITY FROM THE AIR. IF THE HUMIDITY CONTAINED IN THE FLUID EXCEEDS A GIVEN CONCENTRATION, THE BRAKING ACTION BECOMES INSUFFICIENT. NEVER DRAW THE FLUID FROM OPEN OR PARTLY EMPTY CONTAINERS.

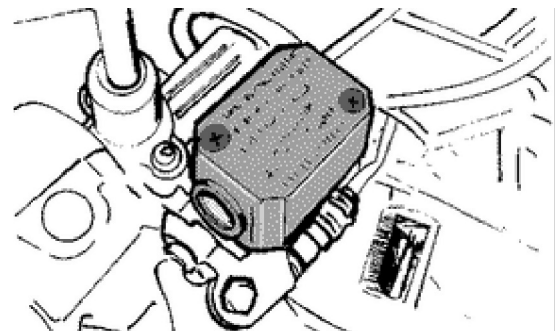

UNDER NORMAL CLIMATIC CONDITIONS THE FLUID SHOULD BE RENEWED EVERY 20,000 KM, OR IN ANY CASE EVERY TWO YEARS.

N.B.

CHANGE THE BRAKE FLUID AND BLEED THE SYSTEM AS DESCRIBED IN CHAPTER BRAKING SYSTEM

Recommended products

TUTELA TOP 4 Brake fluid

Synthetic fluid SAE J1703, NHTSA 116 DOT 4, ISO 4925

Headlight adjustment

Place the unloaded vehicle on flat ground 10 m away from a half-lit white wall and ensure the vehicle axis is perpendicular to the wall.

Mark a horizontal line on the wall at 65 ÷ 70 cm from the ground.

Start the engine, turn on the headlight and set it on high-beam, then adjust the headlight so that the line separating the lit and the non lit regions stays below the line marked on the wall. To adjust the headlight it is necessary to remove the front top cover (see Bodywork Chapter) and act upon screw «**A**» located behind the headlight, as shown in the picture.

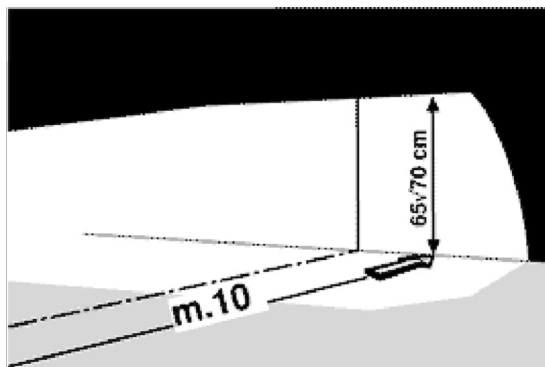

Before carrying out the adjustment operation, check the tyres are inflated at the prescribed pressure.

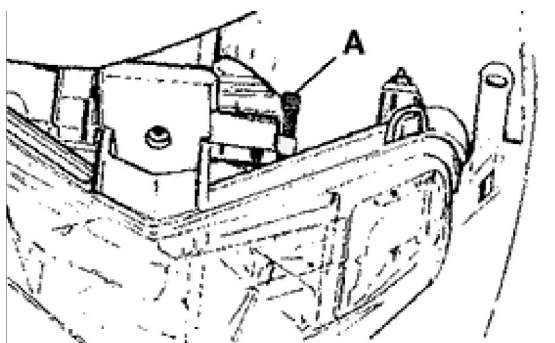

CO check

The check must be carried out after having carefully cleaned all carburettor components, with the air filter clean and the spark plug in good conditions.

- 1) Warm up the engine riding the vehicle at 45 Km/h for ~10 min.; this is necessary to disengage the automatic choke device.
- 2) Shut down the engine in order to carry out operations 3) and 4).
- 3) Insert a ~ 50 cm extension duct to the exhaust gas outlet on the silencer.
- 4) Carefully ensure leak tightness between the exhaust and the duct. Insert the analyser sensor in the duct.
- 5) Start the engine.
- 6) Switch on the high-beam.
- 7) Wait for a few moments, until the idle speed settles.
- 8) **Without ever twisting the throttle** and using the appropriate flux screw, bring the engine up to 1800 ± 100 rpm.
- 9) Adjust the flux screw so to have a "CO" value equal to $3.5\% \pm 0,5\%$.
- 10) Slowly twist the throttle grip until the engine reaches 4,000 rpm, then shut it back down; ensure the idle speed goes back to the initial value, otherwise repeat the operation starting from point (3).

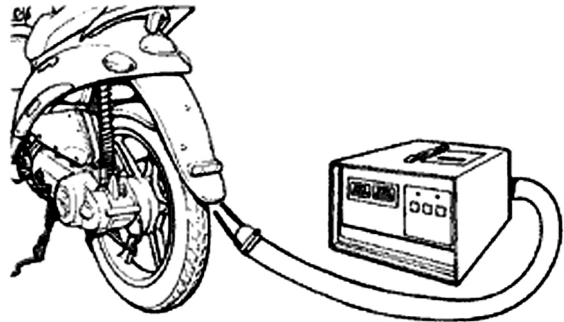

Specific tooling

020332Y Digital rpm counter

494929 Exhaust gas analyser

INDEX OF TOPICS

TROUBLESHOOTING

RIC GUA

This section is for finding solutions to solve problems.

A list of possible causes is provided for each problem and related operations.

Engine

Poor performance

POOR PERFORMANCE

Possible Cause	Work
Carburettor jets or fuel cock clogged or dirty	Remove, wash in solvent and dry with compressed air
Excessive carbon deposits on cylinder ports and in combustion chamber	Decoke
Poor compression: worn compression rings or cylinder	Check parts and replace if necessary
Silencer clogged by excessive carbon deposits	Replace silencer and check carburation and mixer timing
Air filter clogged or dirty	Clean
Choke failure (it remains inserted)	Check mechanical sliding, circuit continuity, power supply, and electrical connections
Clutch slippage	Check and if necessary replace the centrifugal weights and/or clutch housing
Defective sliding of movable pulleys	Check parts and replace if necessary. Lubricate the driven pulley with Montblanc-Molibdenum Grease (drg. 498345).
Worn driving belt	Replace
Carburettor jets clogged or dirty	Remove, wash in solvent and dry with compressed air
Fuel filter on vacuum cock obstructed	Replace cock filter
Worn rollers; presence of oil; dirt	Check presence of the plug with filter on the transmission cover; clean the speed variator; replace worn rollers

Rear wheel spins at idle

REAR WHEEL

Possible Cause	Work
Idle speed set too high	Adjust slow running speed and C.O, if necessary.
Faulty clutch	Check springs/weight of friction and clutch housing pan
Air filter box not sealed	Refit filter box. Replace if it is damaged

Starting difficulties
STARTING DIFFICULTIES

Possible Cause	Work
Carburettor jets clogged or dirty	Remove, wash in solvent and dry with compressed air
Fuel cock failure	Check that the fuel comes through the feed pipe when the engine is started, with the throttle closed; if not, replace the vacuum cock
Choke failure	Check: electrical connections, circuit continuity, mechanical sliding and power supply
Spark plug faulty or electrodes gap incorrect	Check spark plug and electrodes gap. Replace if necessary
Battery is down	Check the battery charge condition. If the battery shows signs of sulfation, replace it. Before installing the new battery, charge it for eight hours with a current corresponding to 1/10 of the capacity of the battery
Engine flooding	Open the throttle wide and try to start the engine. If the engine does not start, remove the spark plug, run the engine with throttle open making sure the cap is connected to the spark plug and the spark plug is earthed, far from the hole. Fit a dry spark plug and start the engine.
Wrong fuel specifications	Drain the fuel and then refuel
Spark plug defective	Brush clean and restore the correct gap between electrodes, or replace with a plug of recommended type. Remember that many engine problems are attributable to the use of an unsuitable spark plug
Intake manifold cracked or clips not tightened	Renew intake manifold and check sealing on head
Cleaner-carburettor union damaged	Replace

Excessive oil consumption/Exhaust smoke
EXCESSIVE CONSUMPTION

Possible Cause	Work
Excessive carbon deposits on cylinder ports and in combustion chamber	Decoke

Engine tends to cut-off at full throttle

ENGINE TENDS TO CUT OUT AT FULL THROTTLE

Possible Cause	Work
Maximum jet dirty - lean carburetion	Wash with solvent and dry with compressed air
Fuel cock failure	Check that the fuel comes through the feed pipe when the engine is started, with the throttle closed; if not, replace the vacuum cock
Water in the carburettor	Empty the basin by the special drain
Float valve faulty	Check float sliding and needle valve operation
Float valve defective	Check float and needle sliding
Fuel vent pipe clogged	Restore the proper tank aeration

Engine tends to cut-off at idle

ENGINE TENDS TO STOP WHEN IDLING

Possible Cause	Work
Idle nozzle dirty	Wash with solvent and dry with compressed air
The choke stays open	Check: electrical connections, circuit continuity, mechanical sliding and power supply
The reed valve does not close	Check / replace the reed pack
Slow running incorrectly tuned up	Tune up slow running and check C.O. level
Spark plug faulty	Replace spark plug with an equivalent part having the prescribed heat grade. Check electrodes gap

High fuel consumption

EXCESSIVE CONSUMPTION

Possible Cause	Work
Air filter clogged or dirty	Clean
Inefficient starter	Check: electric connections, circuit continuity, mechanical sliding, and presence of power

Excessive exhaust noise

INCREASED EXHAUST NOISE

Possible Cause	Work
Secondary air metal pipeline is worn	Check pipeline sealing on crankcase and box, check presence and correct assembly of plug with filter on transmission cover.
Secondary air circuit components faulty	Check components and pipeline, check correct assembly. Replace components if they are damaged

SAS malfunctions

LOOSENESS OF RUBBER UNION OF SECONDARY AIR TUBE TO SILENCER

Possible Cause	Work
Secondary air reed blocking	Replace
Secondary air filter clogged	Clean filter and box
Secondary air union to silencer clogged	Decoke the union taking care not to let the carbon deposits fall inside the silencer

Transmission and brakes

Clutch grabbing or performing inadequately

CLUTCH DEFECTIVE

Possible Cause	Work
Jerky or irregular operation	<p>Check that the weights shift and return smoothly.</p> <p>Check that there is no grease on the weights.</p> <p>Check that the contact surface of the clutch weights with the housing is at the centre, and that the 3 weights have the same specifications.</p> <p>Check that the clutch housing is not scored or does not show anomalous signs of wear. Never run the engine without the clutch housing.</p> <p>Check that the plug with filter on the transmission cover is there</p>

Insufficient braking

BRAKING SYSTEM FAILURE

Possible Cause	Work
Insufficient braking force	<p>The rear brake (drum brake) is adjusted by setting the relative registers (on the wheel), remembering that the wheels must turn freely when the brake levers are fully released.</p> <p>The braking action should start when brake levers are pulled at 1/3 of their travel.</p> <p>Check wear of brake pads. If there are problems that cannot be overcome simply by normal adjustment of the control linkages, proceed to inspect the pads and front brake disc, the shoes and the rear drum.</p> <p>If surfaces are excessively worn or scored, replace the affected parts as necessary</p>
Air bubbles in the braking hydraulic system	Carefully bleed the hydraulic system (spring ac-

Possible Cause	Work
	tion of the brake lever should not be felt)
Fluid leakage	Spring connections, piston gaskets or brake pump failure. Replace
Worn fluid	Change the front brake fluid and restore correct level in the pump
Cables not sliding properly in sheaths	Lubricate or replace
Noisy brake	Check pads and/or shoes wear

Brakes overheating

BRAKES OVERHEATING

Possible Cause	Work
Defective piston sliding	Check the caliper and replace any damaged parts
Brake disc or drum deformed	Check by means of a dial gauge the disc levelness with the wheel correctly mounted, or concentricity of the rear drum

Electrical system

Battery

BATTERY

Possible Cause	Work
Battery	This one component of the system needs checking more frequently and servicing more carefully than any other. If the vehicle is to stand idle for any length of time (one month or longer), the battery will need recharging periodically. The battery discharges completely over a period of around 5 - 6 months. When fitting the battery to the vehicle, take care not to switch the connections: the black earth lead is connected to the negative terminal and the red lead to the positive terminal marked +. To charge the battery, follow the instructions described in Chapter ELECTRICAL EQUIPMENT.

Steering and suspensions

Rear wheel

REAR WHEEL

Possible Cause	Work
Idle speed set too high	Adjust idle speed. Adjust C.O. if necessary
Faulty clutch	Check springs / frictional weights and clutch housing.

Heavy steering

STEERING STIFF

Possible Cause	Work
Unacceptable tightening	Check the tightening torque of the upper and lower collar. If the steering fails to turn smoothly even when correctly tightened, inspect the bearing races and replace if they show signs of uneven wear

Excessive steering play

EXCESSIVE STEERING PLAY

Possible Cause	Work
Excessive steering play	Check the tightening torque of the upper and lower collar. If the steering fails to turn smoothly even when correctly tightened, inspect the bearing races and replace if they show signs of uneven wear

Noisy suspension

NOISY SUSPENSION

Possible Cause	Work
Noisy suspension	If the front suspension is noisy, check: efficiency of front suspension; condition of the ball bearings and relative locking nuts; rubber stroke end bumpers; sliding bushes

Suspension oil leakage

OIL LEAKING FROM SUSPENSION

Possible Cause	Work
Oil leaking from suspension	Check pumping elements and condition of sleeves and sealing rings. Replace if damaged.

INDEX OF TOPICS

ELECTRICAL SYSTEM

IMP ELE

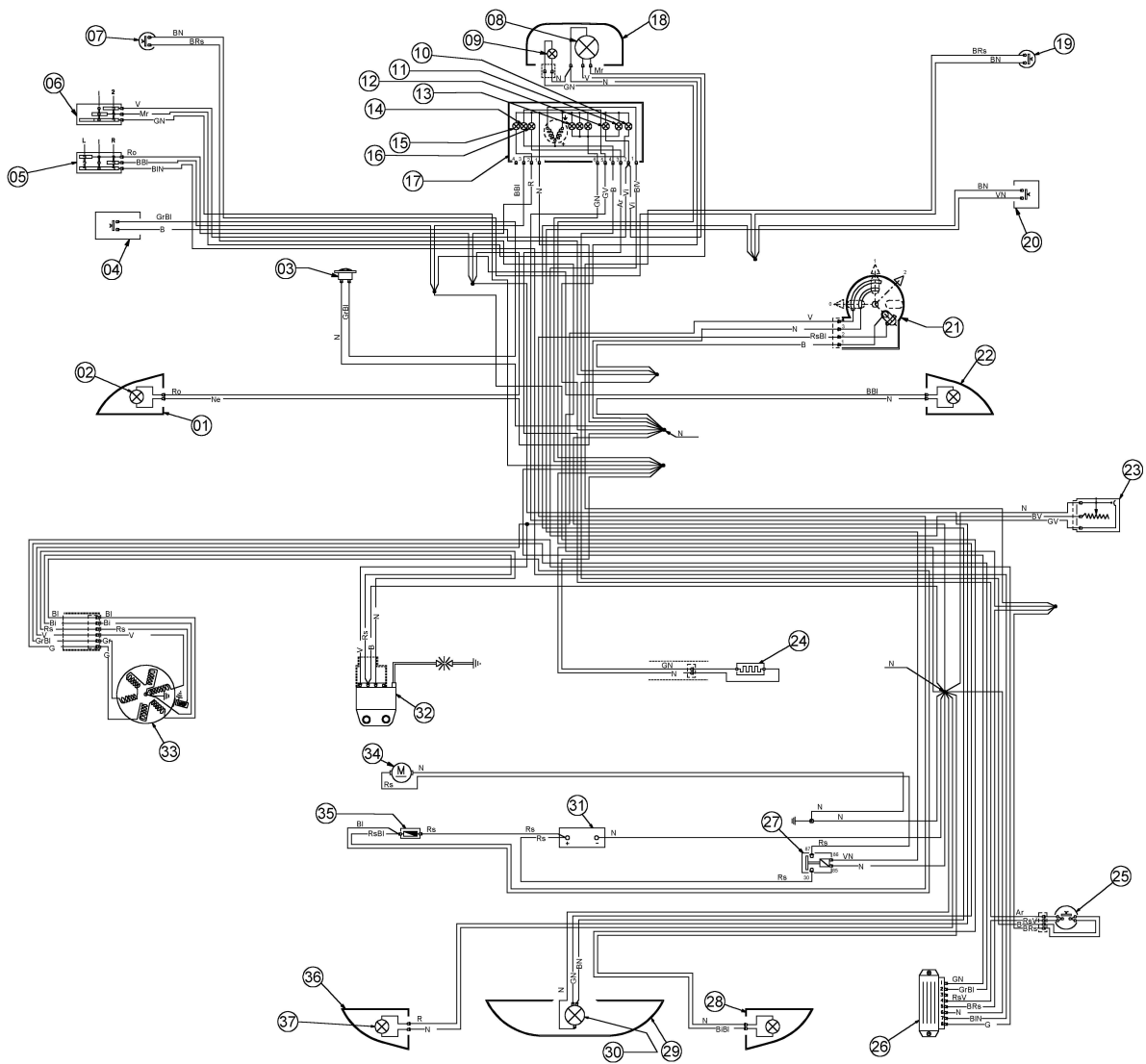

Legend:

1. Front LHS turn signal light; 2 light bulbs for each turn signal light
2. 2 amber light bulbs for turn signal light
3. Horn
4. Horn button
5. Turn signal switch 6. Headlight switch
7. Stop light switch on rear brake
8. Light bulb
9. Headlight bulb
10. RHS turn signal warning light
11. Headlamp warning light
12. High-beam warning light
13. Instrument panel light bulbs

14. Low fuel warning light
15. LHS turn signal warning light
16. Low oil warning light
17. Odometer level gauges with warning lights, 7 light bulbs
18. 2 light bulbs for headlamp
19. Stop switch on front brake
20. Starter button
21. Key-switch
22. Front RHS turn signal light
23. Fuel level sender
24. Automatic choke device
25. Mixer oil warning light sender
26. Voltage regulator
27. Starter relay
28. Rear RHS turn signal light
29. Taillight assembly
30. Stop and taillight bulb
31. Battery
32. Electronic ignition device (CDI)
33. Flywheel magneto
34. Starter motor
35. Fuse holder with 7.5 A fuse
36. Rear LHS turn signal light
37. 2 amber light bulbs for turn signal light

Colour coding for electrical wires:

B = White

Bl = Blue

G = Yellow

Mr = Brown

N = Black

GN = Yellow-Black

Gr = Grey

Rs = Pink

R = Red

Vi = Purple

V = Green

BN = White-Black

BBI = White-Blue

GV = Yellow-Green

Ar = Orange

GrBI = Yellow-Blue

RsBI = Pink-Blue

BIV = Blue-Green

BRs = White-Pink

Conceptual diagrams

Ignition

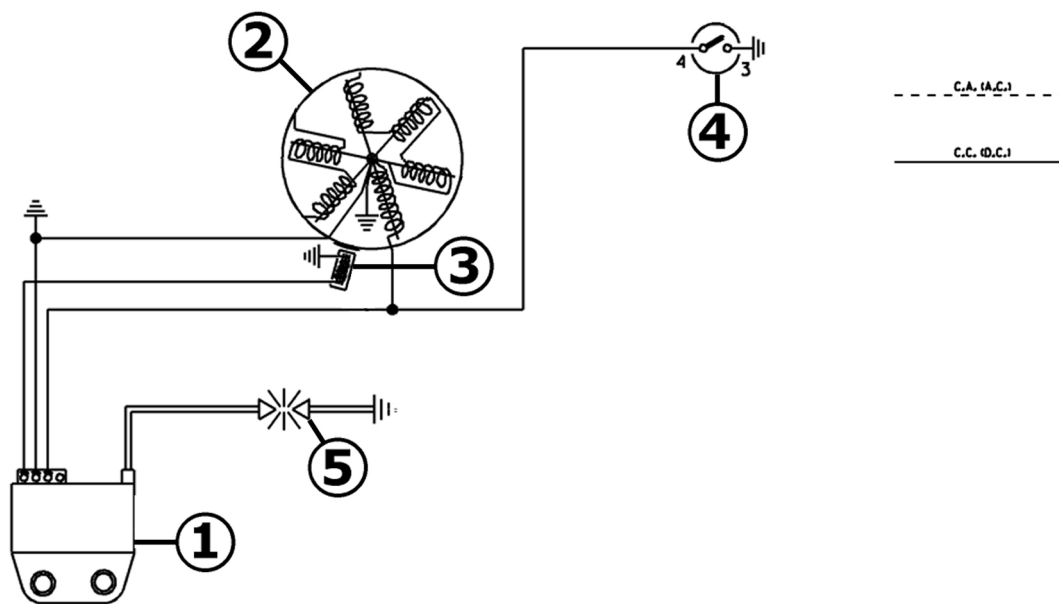

IGNITION

	Specification	Desc./Quantity
1	Electronic controller	
2	Magneto flywheel	
3	Pick - up	
4	Key switch	
5	Spark plug	

Lights

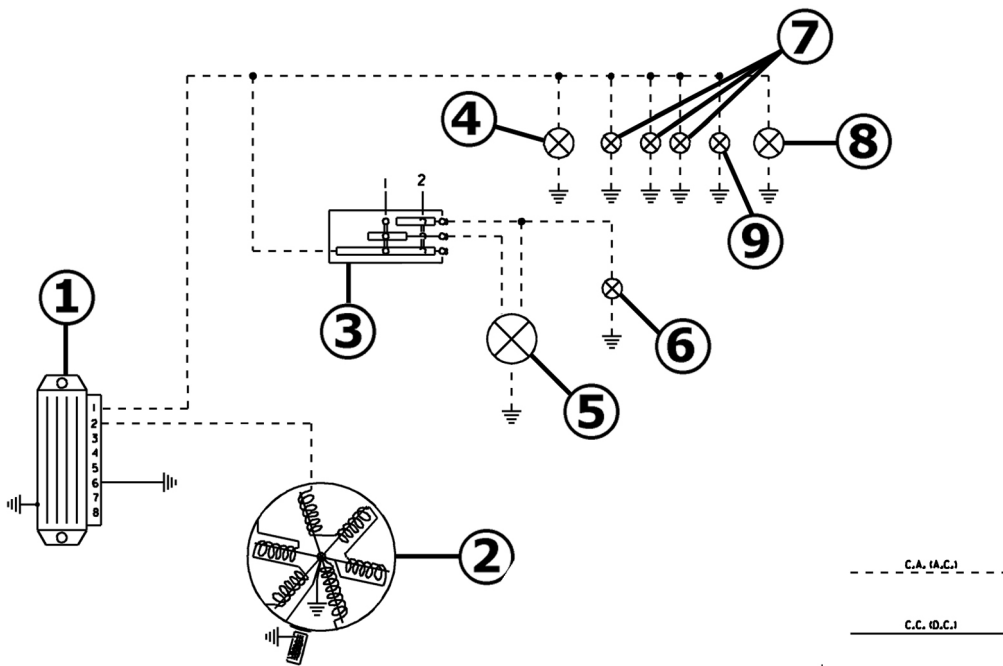

LIGHTS

	Specification	Desc./Quantity
1	Voltage regulator	
2	Magneto flywheel	
3	Light switch with flash	
4	Rear light bulb	12V - 5W
5	Headlight bulb	12V-35/35W
6	High beam warning light bulb	12V-1,2W
7	N°3 instrument lighting bulbs	12V - 1.2W
8	Taillight bulb	12V - 5W
9	Headlight warning light	12V - 1.2W

Battery recharge and starting

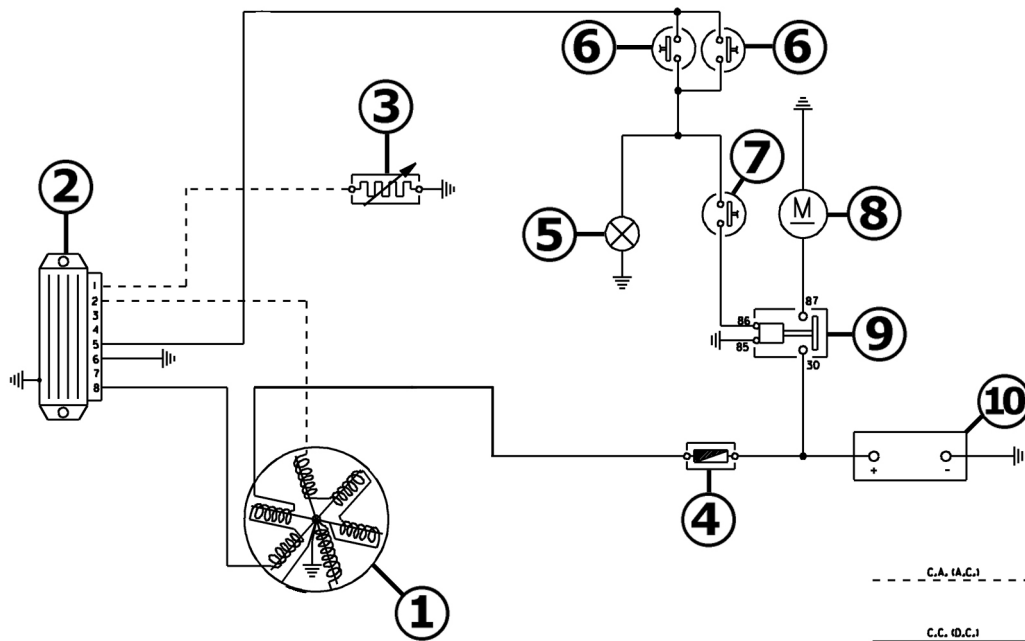

BATTERY RECHARGE AND STARTING SECTION

	Specification	Desc./Quantity
1	Magneto flywheel	
2	Voltage regulator	
3	Automatic starter	
4	Main fuse	7,5A
5	Brake light filament	12V - 21W
6	Front and rear brake light button	
7	Start up button	
8	Starter motor	
9	Remote starter switch	
10	Battery	12V - 4Ah

Safety switches

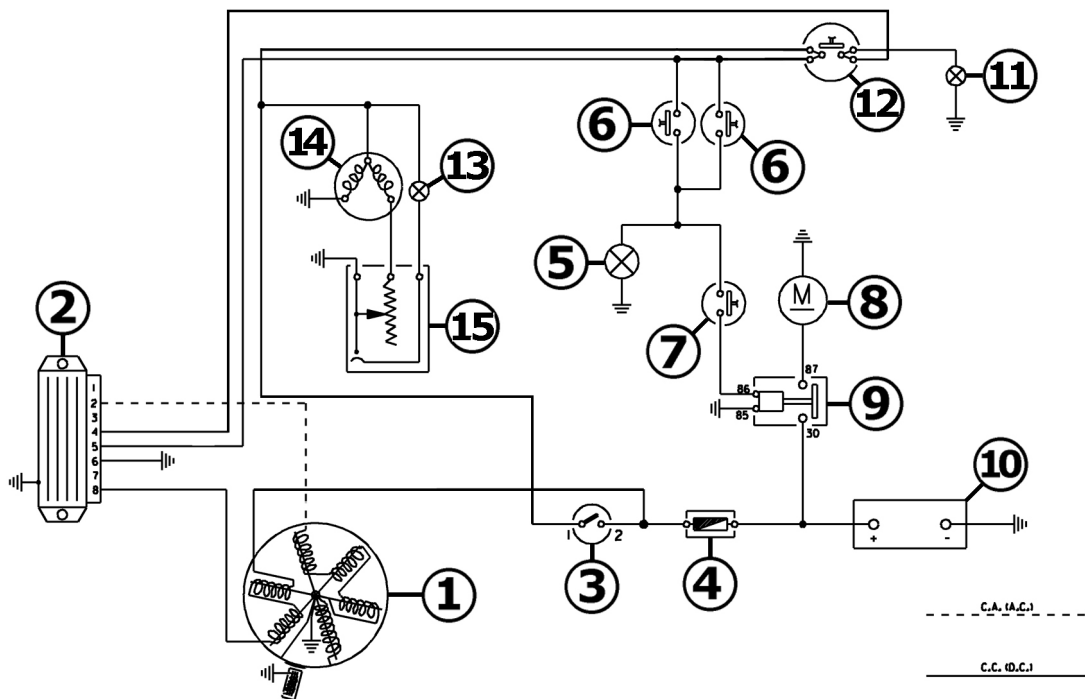

START PERMISSIVE BUTTONS AND LEVEL INDICATORS

	Specification	Desc./Quantity
1	Magneto flywheel	
2	Voltage regulator	
3	Key switch	
4	Main fuse	7,5A
5	Brake light filament	12V - 21W
6	Front and rear brake light button	
7	Start up button	
8	Starter motor	
9	Remote starter switch	
10	Battery	12V - 4Ah
11	Stop light bulb	12V - 1.2W
12	Oil level sender	
13	Reserve fuel light	12V-1,2W
14	Fuel Level Transmitter	
15	Fuel level thermistor	

Turn signal lights

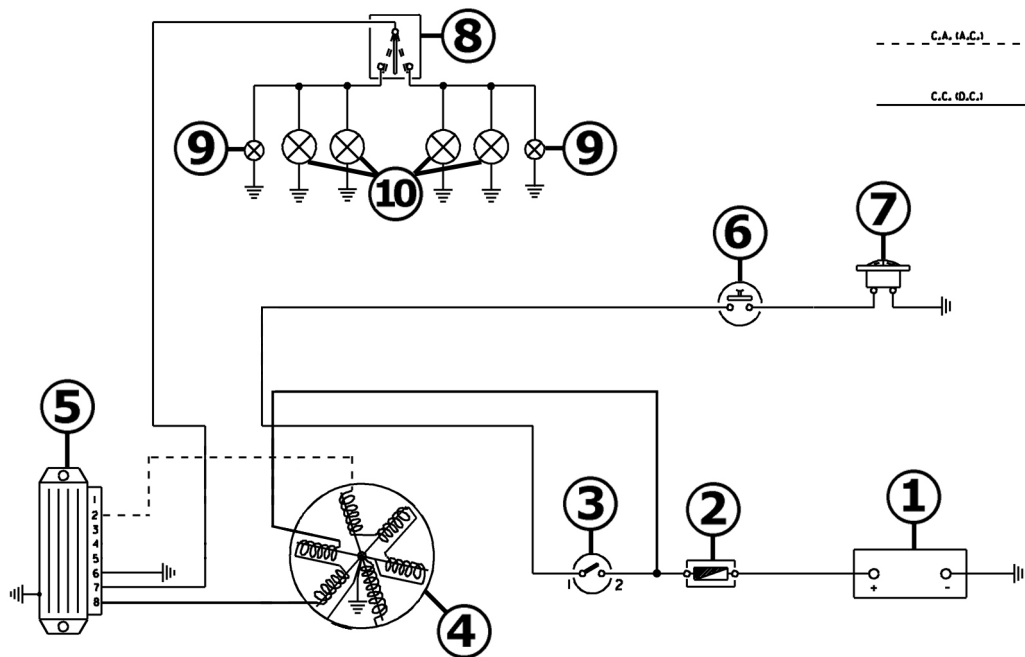

TURN INDICATORS AND HORN

	Specification	Desc./Quantity
1	Battery	12V - 4Ah
2	Main fuse	7,5A
3	Magneto flywheel	
4	Voltage regulator	
5	Horn button	
6	Horn	
7	Indicators switch	
8	Two (2) turn signal warning light bulbs	12V - 2W
9	4 Turn indicator bulbs	12V-10W
10	Key switch	

Checks and inspections

In case of faulty or failed operation of the ignition system and if the cause cannot be found by a simple visual inspection, replace the C.D.I. module with another of the same type and certainly working.

Remember that the disconnections needed to replace the C.D.I. module are to be carried out

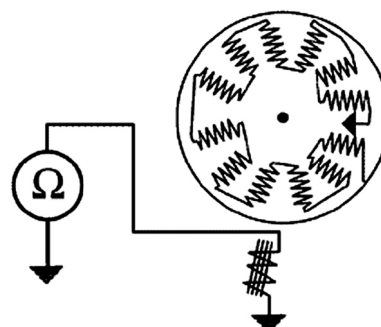

while the engine is switched off.

If the replacement restores the ignition system to proper operation, the fault is to be found in the C.D.I. module, which will have to be replaced.

If faulty or failed operation persists, conduct the following checks on the generator and on the stator components:

After a visual inspection of the electrical connections, it is possible to perform measurements on the stator winding and pick-up (see table), using the specific multimeter.

If, during the checks on the charge coil and the pick-up, anomalies are found, replace the stator and other faulty parts.

Disconnect the connector on the flywheel housing and measure the resistance between each of the two contacts and the earth.

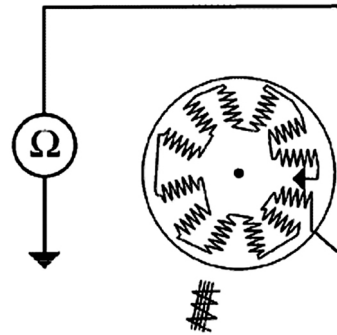

Specific tooling

020331Y Digital multimeter

PICK-UP TEST

	Specification	Desc./Quantity
1	1) Brown and ground cable	~ 170 Ω

STATOR WINDING CHECK

	Specification	Desc./Quantity
1	1) Black and ground cable	~ 1 Ω

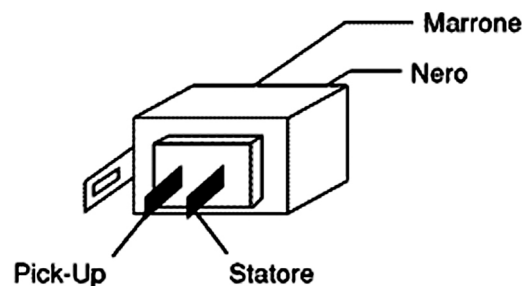

- 1) No-load test: the starter motor, when unloaded, must absorb no more than 10A with a supply voltage $\geq 12V$ and must rotate at $\geq 15,000$ rpm.
- 2) Load test: when the starter motor is so braked that it absorbs 47A with supply voltage $\geq 10V$, torque of $\geq 0.2 \text{ N}\cdot\text{m}$ must be obtained at 10,000 rpm.
- 3) Static torque test: when the rotor is locked and the supply voltage is $<7V$, the absorbed current must not exceed 130A and the torque must be at least $0.55 \text{ N}\cdot\text{m}$

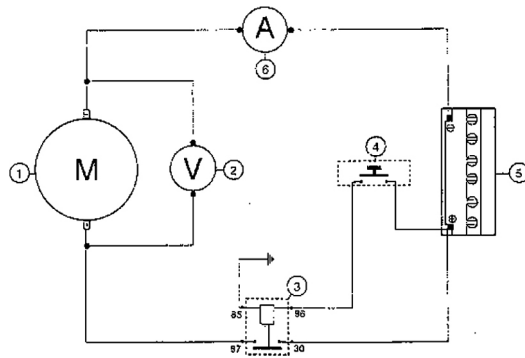

Specifications

- Rated voltage 12V.
- Rated power 0.25 kW.
- Left-hand rotation view from pinion side.
- Connected to the engine by pinion and crown wheel on crankshaft, transmission side.
- Push-button control.
- Battery used for the test: 12V-3,6Ah.

N.B.

THE ABOVE CHARACTERISTICS MUST BE MEASURED WITH A CHARGED BATTERY AND AFTER RUNNING THE STARTER MOTOR FOR 30 SECONDS IN THE CONDITIONS DESCRIBED AT POINT 1.

Ignition circuit

All checks on the electrical equipment involving the disconnection of cables (checks on ignition circuit connections and devices) are to be carried out while the engine is switched off. Should the engine be running, the C.D.I. module could suffer irreparable damage.

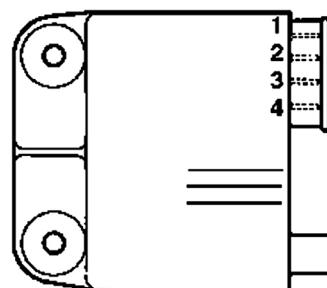

Stator check

- Using a tester check the resistance between the brown-ground and black-ground terminal.

N.B.

THE VALUES ARE STATED FOR AMBIENT TEMPERATURE. CHECKING THE STATOR AT OPERATING TEMPERATURE WILL BRING THE VALUES ABOVE THE STATED ONES.

Electric characteristic

Stator : brown - ground

~ 170 Ω (Pick-Up)

Stator : black-ground

~ 1 Ω (Stator)

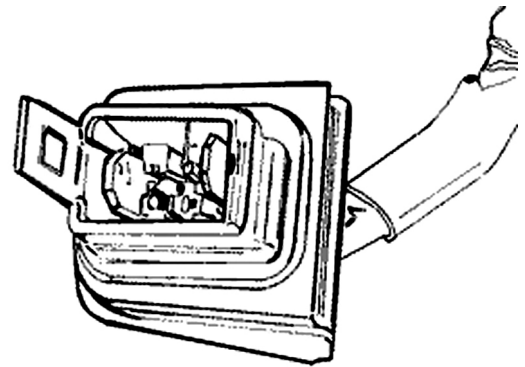

Voltage regulator check

If the voltage regulator is faulty, the following problems may occur depending on the type of regulator malfunction:

- 1) **Bulbs burnt out (regulator in short circuit).**
- 2) **The lighting and electrical starter system do not work (regulator interrupted).**
- 3) Battery fails to charge
- 4) Turn indicators failure

The regulator is provided with earth supplied from the electrical equipment, therefore the regulator body does not supply earth to the internal circuits. Check the insulation between each terminal of the regulator and its body, using the specific tester.

1) BURNING OUT OF BULBS

The regulator must be replaced, as it is certainly faulty.

2) LIGHTS AND STARTING DEVICE FAILURE

Expose the voltage regulator by removing the plastic cover from the front shield, start the engine and let it idle. Keep all vehicle lights out.

Fit the positive prod of the multimeter (set for measuring alternating voltages) to terminal no. 1 (grey wire) and the negative prod to terminal no. 2 (black wire). Check if voltage is present (see fig-

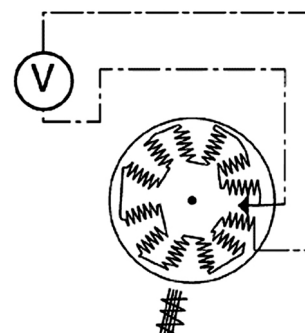

ure).

If there is no voltage, fit the negative prod directly on earth; if voltage is measured, check the regulator's earth cables; otherwise replace the regulator because it is certainly broken.

Finally, you may measure the voltage supplied by the stator:

- Disconnect the regulator connector, fit a multi-meter between the grey-blue cable (4) and the earth to measure alternate voltages (see figure).
- Voltage delivered at 2000 revs/min should be about 25 - 35V.

If also in this case no values are obtained, replace the regulator because it is damaged.

N.B.

FOR THE ABOVE MEASUREMENTS, USE AN ANALOGUE MULTIMETER FOR ALTERNATING VOLTAGES AND KEEP THE ENGINE IDLING SO AS TO OBTAIN AN ALTERNATING VOLTAGE WITH A FREQUENCY AS CLOSE AS POSSIBLE TO 50 HZ AND MEASURE THE ACTIVE TENSION SUPPLIED BY THE REGULATOR (APPROX. 12 V).

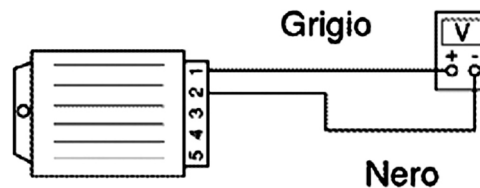

~ 12V a 1900÷2000 giri/min.

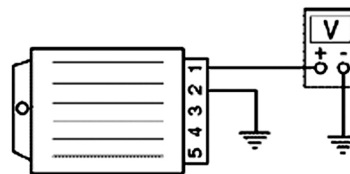

~ 12V a 1900÷2000 giri/min.

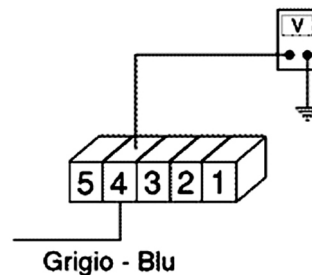

~ 25÷35V a 1900÷2000 giri/min.

3) BATTERY FAILS TO CHARGE

A fault on the direct current section of the regulator can result in the following problems, depending on the type of fault:

- a) **Blowing of the protecting fuse due to an overvoltage condition (regulator shorted) preventing the battery from being recharged.**
- b) **Battery fails to recharge (regulator circuit interrupted).**

Interventions

- a) Fuse blow (regulator short-circuited).

Check that the wiring that connects the protecting

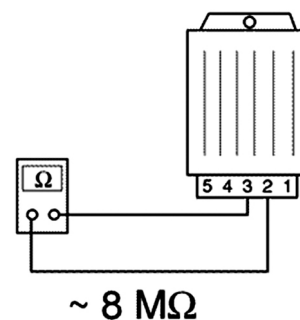

~ 8 MΩ

fuse to the ignition switch is not damaged, which would cause a short circuit to earth and rule out possible regulator damage; if the related fuse blows only after the ignition switch has been turned to "ON" and if the regulator connector is detached, check that the wiring and devices following the ignition switch are not shorted to earth. Measure the resistance between contacts 3 (White) and 2 (Black) on the voltage regulator (the connector must be disconnected).

The resistance should be approximately 8 MW. If the measurement differs greatly from the prescribed value, the regulator is shorted and needs to be replaced.

b) Battery fails to recharge (regulator circuit interrupted).

To check the voltage regulator recharge section, first connect 2 multimeters (one to measure the voltage and the other one to measure the current) as shown in the second figure and use the following procedure:

Start the engine (temporarily connect the red cable to the positive terminal to avoid damaging the instrument).

Check that voltage is at least 13V while engine is idling (battery charged), and that the recharge current is 1.5 - 2A with lights off. By increasing the engine revs number, the recharge voltage and current progressively increase, at speeds higher than 4000 revs/min. the recharge current should be about 4.5A; by turning on the lights, the stoplight and using the horn, the current values may be $\geq 5A$ and the voltage value 14 - 14.5V (regulator threshold value).

If different values are obtained, replace the

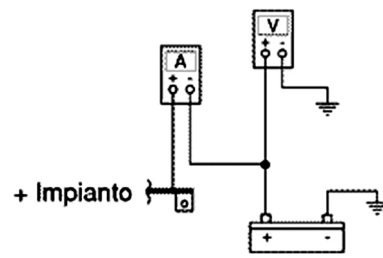

~ 2000 giri/min 1,3V/1,5÷2A
> 4000 giri/min 14÷14,5V > 4A

regulator, otherwise check the wires and connections.

Electric characteristic

Replace the regulator since

~ 8 MΩ

4) TURN INDICATORS FAIL TO OPERATE

In case of turn indicators fault, proceed as follows:

- Remove the regulator connector and insert the multimeter prods between white wire (3) and black wire (2).
 - Turn the key switch to ON and check that the battery is powered. If no voltage is measured, repeat the test between the earth and white cable. If the check is still unsuccessful, check the cables and the contacts on the key switch and battery. If the battery voltage is measured, check the regulator earth cables (black cable)
 - If the above checks are successful, jump contacts 5 (blue/black) and 3 (white) on the connector, turn the key switch to ON and turn the flashlights switch to the left and to the right to check if lights goes on (these are directly fed by the battery).
- If the flashlights do not go on, check the cables and the switch operation; otherwise, replace the regulator since it is faulty.

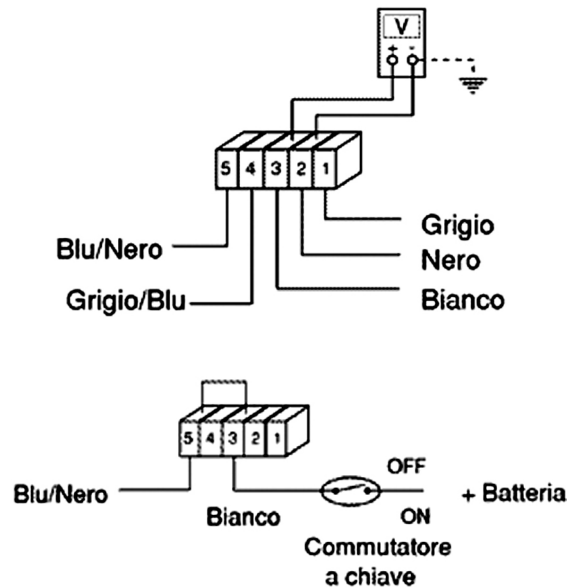

Specific tooling

020331Y Digital multimeter

Sealed battery

Putting a sealed battery into service If the vehicle is equipped with a sealed battery, servicing is lim-

ited to checking the charge level and, if necessary, recharging the battery.

These operations must be performed during pre-delivery, and every six months of open-circuit storage.

Therefore, in addition to checking and, if necessary, charging the battery before delivery, it is necessary to carry out these operations before storing the vehicle, and subsequently every six months.

RECHARGING THE BATTERY FOLLOWING OPEN-CIRCUIT STORAGE

1) Checking the voltage

Before installing the battery on the vehicle, measure the open-circuit voltage with an ordinary multimeter.

- If the voltage exceeds 12.60 V, the battery can be installed without recharging.
- If the voltage is less than 12.60 V, recharge the battery as described at item 2).

2) Constant-voltage charging method

- Constant voltage: 14.40-14.70 V
- Initial charging current: 0.3-0.5 x rating
- Charging time:
- Recommended 10-12 hrs

Minimum 6 hrs

Maximum 24 hrs

3) Constant-current charging method

- Initial charging current: 1/10 of rating
- Charging time: Maximum 5 hrs

WARNING

WHEN THE BATTERY IS DEEPLY DISCHARGED (FAR BELOW 12.6V), 5 HOURS' RECHARGING MAY NOT BE ENOUGH TO OBTAIN OPTIMUM PERFORMANCE. IN THESE CONDITIONS, HOWEVER, TO AVOID DAMAGING THE BATTERY BEYOND

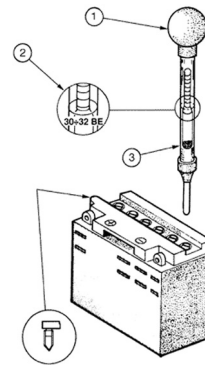

REPAIR, IT IS ESSENTIAL NOT TO RE-CHARGE IT FOR MORE THAN 8 CONSECUTIVE HOURS.

- 1 hold the tube upright
- 2 visually check the level
- 3 the float must be released

Dry-charge battery

- 1) - Remove the short closed tube and the plugs. Fill the cells to the upper level with battery acid, specific gravity 1.26 corresponding to 30° Bé at 15°C.
- 2) - Leave the battery to stand for about 2 hours and then top up once again with battery acid.
- 3) - Within 24 hours, recharge the battery using the specific battery charger 020333Y (single) or 020334Y (multiple). Apply an intensity equivalent to about 1/10 of the battery rating until the acid density is approximately 1.27, corresponding to 31° Bé, and these values stabilize.
- 4) - When the battery is fully charged, top up with **distilled water**, refit the plugs and clean the battery case.
- 5) - After completing the above operations, proceed to install the battery on the vehicle, taking care to observe the connections between the wiring and the battery terminals.

WARNING

AFTER INSTALLING THE BATTERY AND IN ORDER TO PROVIDE A VENT FOR THE GASES FORMING INSIDE IT, REPLACE THE SHORT CLOSED TUBE NEXT TO THE POSITIVE (+) TERMINAL WITH THE CORRESPONDING LONG OPEN TUBE WHICH IS PRESENT ON THE VEHICLE. CHECK THAT THE TUBE SLOTS ARE TURNED TO THE BATTERY SIDE

Specific tooling

020333Y Single battery charger

020334Y Multiple battery charger

The battery is the electrical component which requires the most constant care and accurate maintenance. The main maintenance rules are as follows:

1) Checking the electrolyte level

Frequently check that the electrolyte reaches the upper level. To top up, only use distilled water.

If you need to top up the battery too frequently, check the vehicle electrical equipment as the battery is certainly working in overload conditions, which will lead to rapid deterioration.

2) Checking the battery charge

After restoring the electrolyte level, check its density with the special hydrometer (see figure).

When the battery is charged, electrolyte density must be between 30 and 32 Bé, corresponding to specific gravity of 1.26-1.28 at a temperature not lower than 15°C.

If density has fallen below 20° Bé, the battery is completely discharged and needs recharging.

At the end of the charging, check the level and density of the electrolyte in each cell. If the vehicle is not used for some time (1 month or more) the battery must be periodically recharged.

In three months the battery runs down completely.

When reinstalling the battery on the vehicle, take care not to invert the connections. The black (-) earth wire must be connected to the negative (-) terminal whereas the two red (+) wires must be connected to the positive (+) terminal.

Normal bench charging must be carried out with the specific battery charge (single) or (multiple).

Choose the charger setting corresponding to the type of battery to be recharged. Ensure you connect up to the battery with the correct polarity (+ to + and - to -). The plugs must be removed from the battery throughout the charging procedure.

4) Cleaning the battery

Keep the battery clean, especially the top; coat the terminals with Vaseline.

WARNING

BEFORE CHARGING THE BATTERY REMOVE ALL CELL PLUGS. KEEP FREE FLAMES OR SPARKS AWAY FROM THE BATTERY DURING RECHARGE.

WHEN THE BATTERY HAS TO BE REMOVED FROM THE VEHICLE, DISCONNECT THE NEGATIVE TERMINAL FIRST.

CAUTION

NEVER USE FUSES HAVING A GREATER CAPACITY THAN THE ONE RECOMMENDED. THE USE OF A FUSE OF UNSUITABLE CAPACITY MAY RESULT IN SERIOUS DAMAGE TO THE WHOLE VEHICLE OR EVEN CAUSE A FIRE.

CAUTION

NORMAL DRINKING WATER CONTAINS SALTS THAT ARE HARMFUL FOR BATTERIES. USE ONLY DISTILLED WATER.

CAUTION

TO ENSURE MAXIMUM PERFORMANCE THE BATTERY MUST BE CHARGED BEFORE USING THE VEHICLE.

INSUFFICIENT BATTERY CHARGE OR LOW ELECTROLYTE LEVEL WHEN FIRST USED WILL RESULT IN PREMATURE FAILURE OF THE BATTERY.

Specific tooling

020333Y Single battery charger

020334Y Multiple battery charger

WARNING

BATTERY ELECTROLYTE IS POISONOUS AND CAN CAUSE SERIOUS BURNS AS IT CONTAINS SULPHURIC ACID. AVOID CONTACT WITH THE EYES, THE SKIN AND GARMENTS. IN CASE OF CONTACT WITH THE EYES OR SKIN RINSE ABUNDANTLY WITH WATER FOR ABOUT 15 MINUTES AND SEEK IMMEDIATE MEDICAL ASSISTANCE. IF THE LIQUID IS INGESTED IMMEDIATELY DRINK LARGE QUANTITIES OF WATER OR MILK. SUBSEQUENTLY DRINK MILK OF MAGNESIA, BEATEN EGG OR VEGETABLE OIL. CALL A DOCTOR WITHOUT DELAY. BATTERIES PRODUCE EXPLOSIVE GASES. KEEP AWAY OPEN FLAMES, SPARKS AND CIGARETTES. WHEN A BATTERY IS CHARGED IN CLOSED PLACES ENSURE ADEQUATE VENTILATION. ALWAYS PROTECT THE EYES WHEN WORKING IN THE PROXIMITY OF BATTERIES. POSITION THE TUBE BETWEEN THE MUDGUARD AND THE FILTER. KEEP OUT OF REACH OF CHILDREN.

Connectors

Dashboard

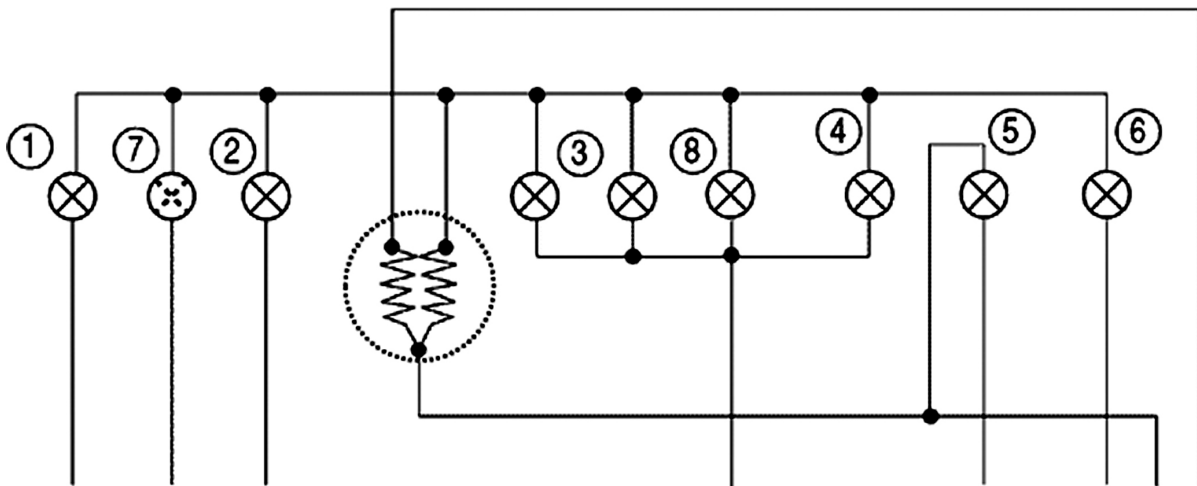

INSTRUMENT PANEL

	Specification	Desc./Quantity
1	left turn indicator warning light	12V-2W
2	High beam warning light bulb	12V-1,2W
3	Instrument panel lighting bulb	12V-1,2W
4	Headlight warning light	12V - 1.2W
5	Reserve fuel light	12V-1,2W
6	Right turn indicator warning light	12V-2W
7	Available warning light	
8	Instrument panel lighting bulb	12V-2W

INDEX OF TOPICS

ENGINE FROM VEHICLE

MOT VE

Exhaust assy. Removal

- Remove the two nuts securing the manifold to the head

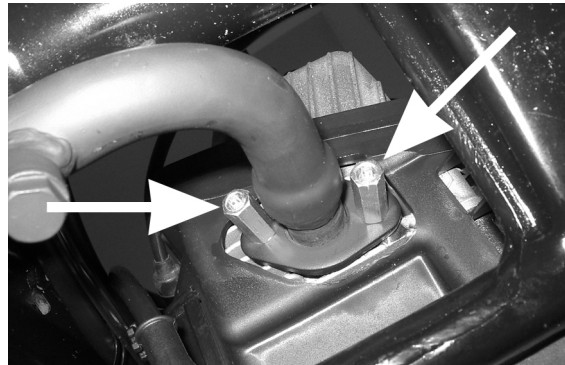

- Unscrew the two screws securing the silencer to the crankcase then remove the complete muffler paying attention to the interference between its support bracket and the cooling casing.

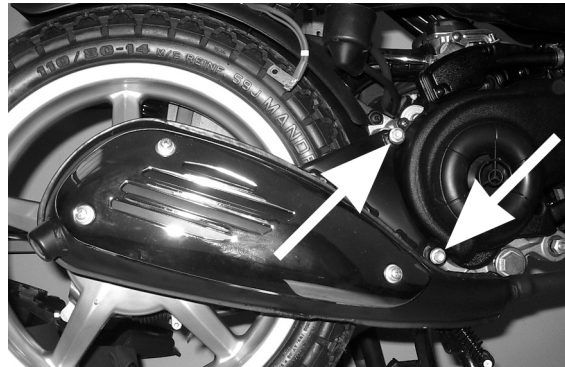

Removal of the engine from the vehicle

Reassembling engine to frame

Perform the disassembly steps in reverse order. Observe the prescribed tightening torques.

Locking torques (N*m)

Swing-arm/engine hinge nut $33 \div 41$ Engine/shock absorber $33 \div 41$ N·m

Removing the engine/connecting arm pivot pin

Remove the nut shown in the figure and then withdraw the pin.



Removing the engine/shock absorber pivot pin

Remove the nut shown in the figure and then withdraw the pin.

Disassembling engine from frame

- Disconnect the battery.
- Disassemble the complete exhaust unit.
- Remove the rear wheel.
- Disassemble the rear brake linkage.
- Disconnect the electrical terminals.
- Disassemble the throttle and mixer control cables.
- Disconnect the pipelines (fuel - oil - vacuum tap control).

WARNING

HANDLE PETROL WITH THE UTMOST CARE.

CAUTION

WHEN INSTALLING THE BATTERY ALWAYS CONNECT THE POSITIVE LEAD BEFORE THE NEGATIVE LEAD.

WARNING

WEAR PROTECTIVE GOGGLES WHEN USING HAMMERING TOOLS.

INDEX OF TOPICS

ENGINE

MOT

Automatic transmission

Transmission cover

- Loosen the 15 screws and remove the transmission cover with the aid of a mallet.

N.B.

THE CRANKCASE IS RESTRAINED BY THE TIGHT FITTING BETWEEN THE SHAFT OF THE DRIVEN HALF-PULLEY AND THE BEARING HOUSED ONTO THE CRANKCASE.

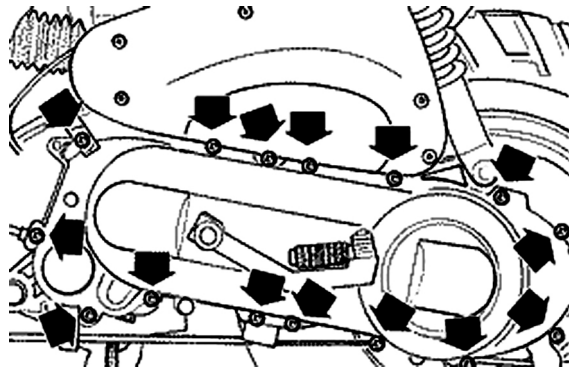

Kickstart

- Remove the screw shown in the figure and detach the kick-start lever.
- When refitting, follow the above operations in the reverse order, tightening the screw to the prescribed torque.

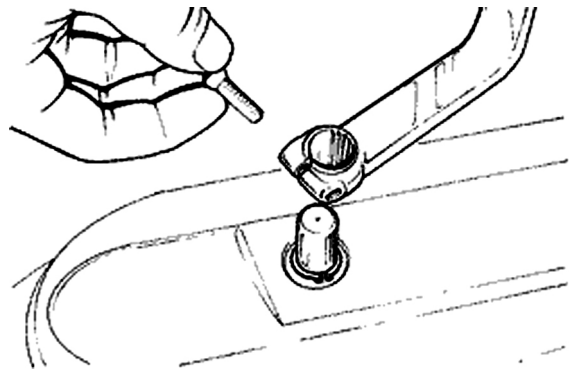

Locking torques (N*m)

Kick-start lever replacement: 12 ÷ 13 N·m

-
- Remove the split ring positioned on the external side of the transmission cover.
 - Remove the drive gear from its housing, decreasing the tension that the toothed segment applies via the spring; to do so, it is necessary to slightly rotate the toothed segment (see figure).

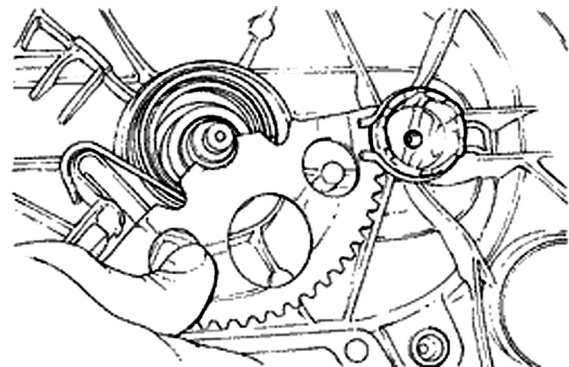

CAUTION

WHEN REMOVING THE GEAR, PAY PARTICULAR ATTENTION TO THE LOADING OF THE SPRING AS THIS MAY BE DANGEROUS FOR THE OPERATOR.

-
- During the reassembly, apply some of the re-
-

commended grease on the bushing, the spring, and the toothed segment.

- To load the spring, use the special tool as shown in the figure.
- Refit the split ring after checking its condition.

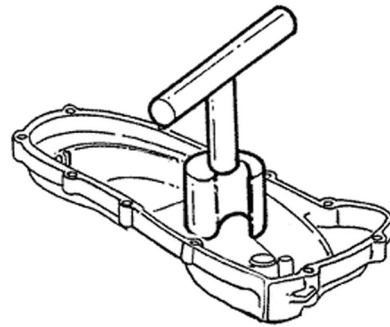

Specific tooling

020261Y Kick-starter spring assembler

Recommended products

JOTA 3 FS Speedometer transmission

Lithium soap grease NLGI 33

Removing the driven pulley shaft bearing

- Slightly heat the crankcase on the inside to avoid damaging the painted surface. Remove the bearing using the driven pulley shaft or a pin of the same diameter.

N.B.

IF THIS IS DIFFICULT A GENERIC 8 MM EXTRACTOR FOR INNER PARTS CAN BE USED.

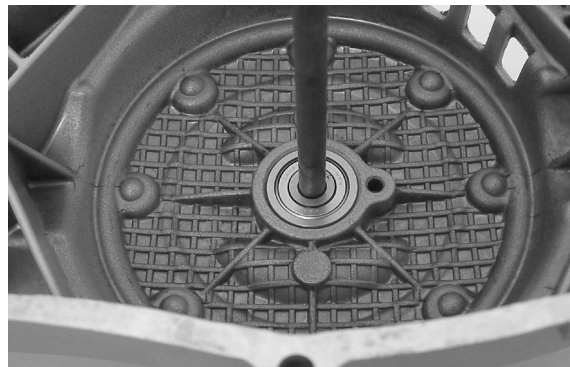

Refitting the driven pulley shaft bearing

- After slightly heating the crankcase on the inside, fit the bearing using a bush of the same diameter as the bearing outer race.

N.B.

WHEN REFITTING, ALWAYS REPLACE THE BEARING WITH A NEW ONE.

CAUTION

WHEN REMOVING/REFITTING THE BEARING, TAKE CARE NOT TO DAMAGE THE PAINTED SURFACE.

Removing the driven pulley

- Lock the clutch bell housing with the specific tool.
- Remove the nut, the clutch bell housing and the

whole of the driven pulley assembly.

N.B.

THE ASSEMBLY CAN ALSO BE REMOVED WITH THE DRIVE PULLEY IN PLACE.

Specific tooling

020565Y Compass flywheel stop spanner



Inspecting the clutch drum

- To verify that the bell clutch is not usurata or damaged.
- To measure the inner diameter of the bell clutch.

Characteristic

Clutch bell diameter/standard value

Ø 107+0,2 +0 mm

Clutch bell diameter/max. value allowed after use

Ø 107,5 mm

Found eccentricity /max.

0,20 mm

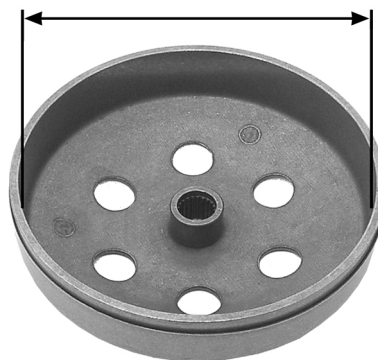

Removing the clutch

- Fit the tool with the long pins screwed on from the outside in positions «A». Insert the driven pulley assembly into the tool and tighten the central screw.

CAUTION

OVERTIGHTENING OF THE CENTRAL SCREW CAUSES THE DISTORTION OF THE TOOL.

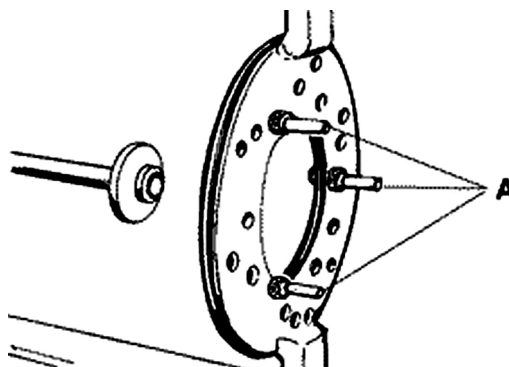

- Using a 34 mm socket wrench, remove the clutch locknut.
- Loosen the central screw, unloading the spring

of the driven pulley assembly.

- Separate the components.

Specific tooling

020444Y Driven half pulley spring compressor tool

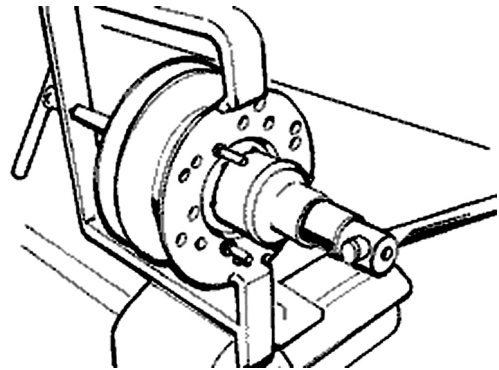

Inspecting the clutch

- Check the thickness of the clutch mass friction material.
- The masses must exhibit no traces of lubricants; in that case, check the driven pulley unit seals.

N.B.

UPON RUNNING-IN, THE MASSES MUST EXHIBIT A CENTRAL CONTACT SURFACE AND MUST NOT BE DIFFERENT FROM ONE ANOTHER.

DIFFERENT CONDITIONS MAY CAUSE THE CLUTCH TEARING.

CAUTION

DO NOT OPEN THE MASSES USING TOOLS TO PREVENT A VARIATION IN THE RETURN SPRING LOAD.

Characteristic

Check . Minimum thickness

1 mm

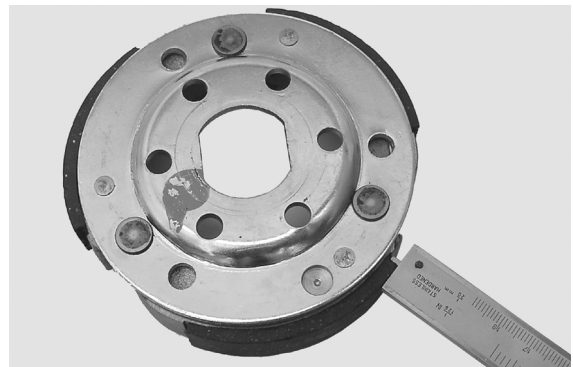

Pin retaining collar

- Remove the collar with the aid of two screw-drivers.



- Remove the three guide pins and the movable half pulley.

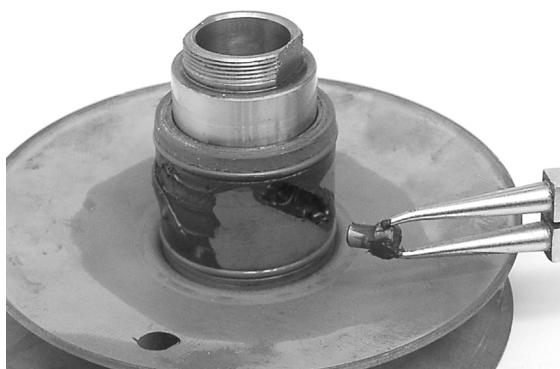

Removing the driven half-pulley bearing

- Remove the roller bearing using the specific extractor inserted from the lower side of the stationary half pulley

CAUTION

POSITION THE SEALING EDGE OF THE EXTRACTION PLIERS BETWEEN THE END OF THE BEARING AND THE BUILT-IN SEAL RING.

Specific tooling

001467y029 Bell



- Remove the snap ring from the roller bearing.
- Remove the roller bearing from the side of the clutch using the specific device.

N.B.

ADEQUATELY SUPPORT THE HALF PULLEY TO PREVENT THE DRIVE BELT SLIDING SURFACE FROM BEING DISTORTED.

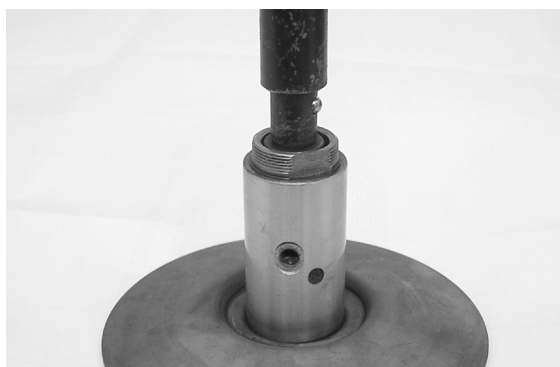

Specific tooling**020376Y Handle for punches****020363Y 20mm guide**

Inspecting the driven fixed half-pulley

- Make sure there are no signs of wear on the work surface of the belts, if there are replace the half pulley.
- Make sure the bearing do not show signs of unusual wear.
- Measure the external diameter of the pulley bushing.

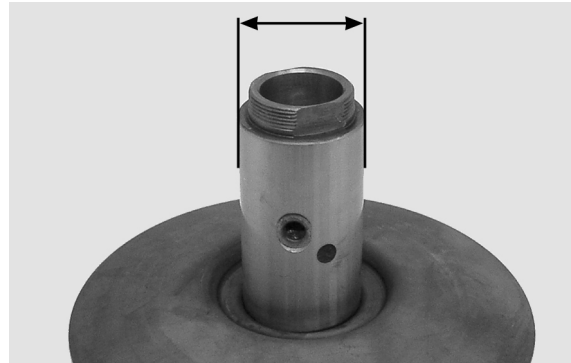
**Characteristic****Standard diameter**

Ø 33,965 ÷ 33,985 mm

Stationary driven half pulley/ Minimum diameter allowed after useØ 33,96 mm

Inspecting the driven sliding half-pulley

- Remove the two inner seal rings and the two O-rings.
- Measure the inside diameter of the movable half pulley bushing.

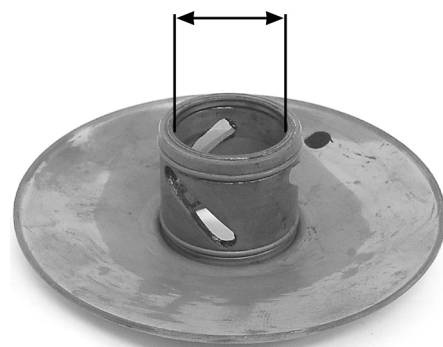
**Characteristic****Maximum allowable diameter**Ø 34,08 mm

- Check the belt contact surfaces.
 - Insert the new oil guards and O-rings on the mobile half pulley.
 - Assemble the half pulley on the bushing.
-

Recommended products**TUTELA MRM 2 Grease for the phonic wheel turning ring**

Molybdenum disulphide grease and lithium soap



- Make sure the pins and collar are not worn, reassemble the pins and collar.
- Use a greaser with a curved spout to lubricate the driven pulley unit with around 6 gr. of grease, this operation must be carried out through one of the holes inside the bushing until grease comes out of the opposite hole. This operation is necessary to avoid the presence of grease beyond the O-rings.

Recommended products**TUTELA MRM 2 Grease for the phonic wheel turning ring**

Molybdenum disulphide grease and lithium soap

Refitting the driven half-pulley bearing

- Fit a new ball bearing with the specific tools.
- Fit the ball bearing circlip.
- Fit the new roller bearing so that the lettering is visible from the outside.

CAUTION

ADEQUATELY SUPPORT THE HALF PULLEY TO AVOID DAMAGING THE THREADED END WHILE FITTING THE BEARINGS.

**Specific tooling**

020376Y Handle for punches

020456Y Ø 24 mm adaptor

020362y 12 mm guide

020171y Roller bearing drift

Inspecting the clutch spring

- Make sure that the driven pulley contrast spring is not deformed.
- Minimum length allowed after use

Characteristic**Standard length**

118 mm

Limit after use

XXXX

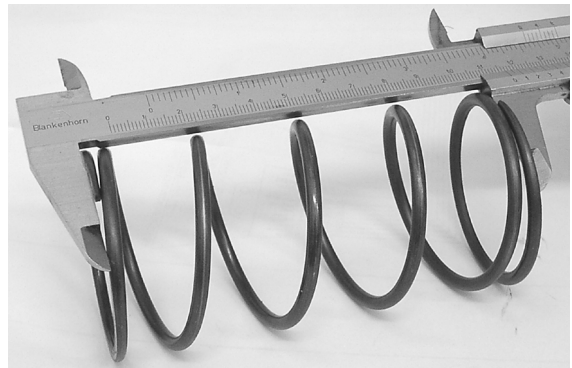
**Refitting the clutch**

- Preassemble the driven pulley unit with spring, sheathing and clutch.
- Position the spring with the plastic shielding supporting the clutch
- Insert the parts in the device and preload the spring, being careful not to damage the plastic sheathing and the end of the threaded shank.

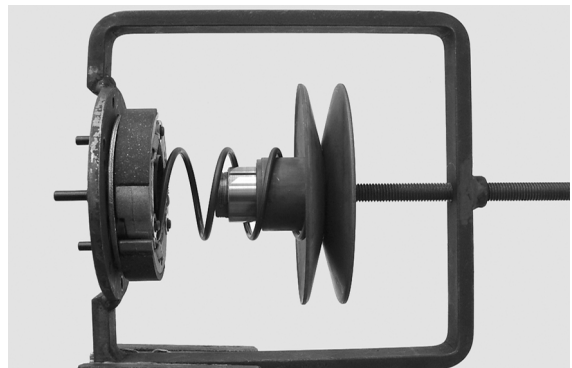

- Reassemble the nut securing the clutch and tighten to the prescribed torque.

CAUTION

TO AVOID DAMAGING THE CLUTCH NUT, USE A SOCKET WRENCH WITH A SMALL BEVEL.

CAUTION

POSITION THE UNBEVELLED SURFACE OF THE NUT IN CONTACT WITH THE CLUTCH.

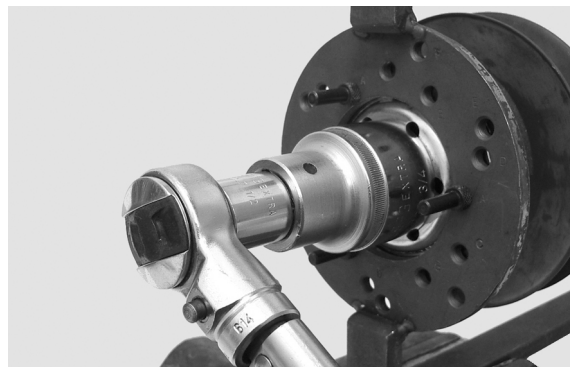
**Locking torques (N*m)**

Nut locking clutch assembly on pulley 55 ÷ 60 Nm

Refitting the driven pulley

- Fit the driven pulley assembly, the clutch bell housing and the nut using the specific tool.

Specific tooling

020565Y Compass flywheel stop spanner

Locking torques (N*m)

Driven pulley shaft nut 40 -÷ 44 Nm

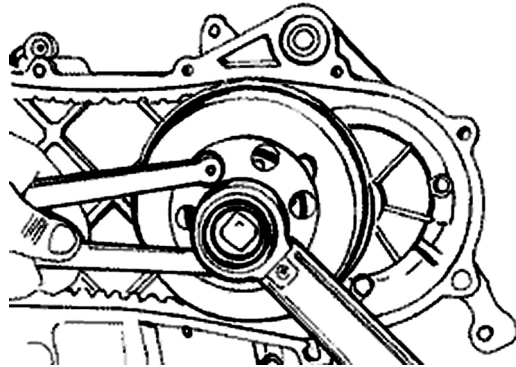
**Drive-belt**

- Make sure the transmission belt is not damaged and does not have cracks in the toothed grooves.
- Check the width of the belt.

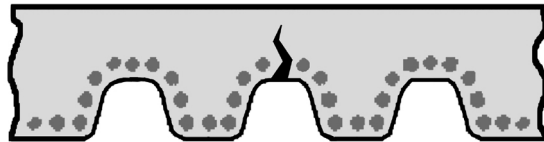
**Characteristic**

transmission belt/Minimum width

17,5 mm

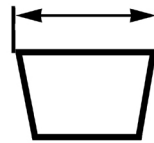
**Removing the driving pulley**

- Lock the pulley with the specific tool.
- Remove the central nut with the related washer, then remove the drive and the plastic fan.
- Remove the fixed half pulley.

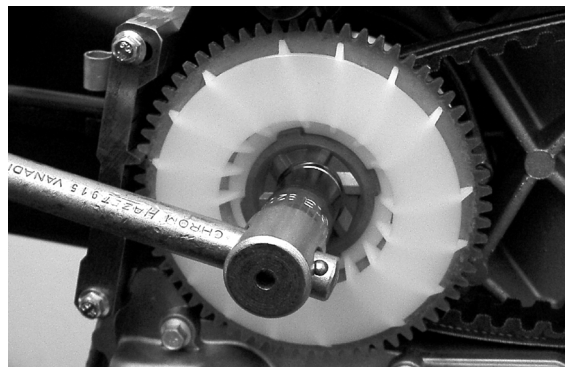

- Remove the belt, washer and remove the mobile half pulley with its bushing, being careful of the rollers and contrast plate fitted loosely on it.

Specific tooling

020451y Drive pulley stop spanner

Mixer gears and belt

- Remove belt and gear

CAUTION

DO NOT TWIST THE BELT

CAUTION

DO NOT TWIST OR BEND THE BELT WHEN REFITTING IT

CAUTION

BEFORE REFITTING THE BELT, CAREFULLY LUBRICATE THE PIN AND THE MIXER DRIVE GEAR BUSHING WITH OIL, MAKING SURE THIS IS FREE FROM ANY LOAD.

N.B.

REPLACE THE BELT EVERY 20,000 KM.

Recommended products

CONSTANT GLY 2100 product description

oil

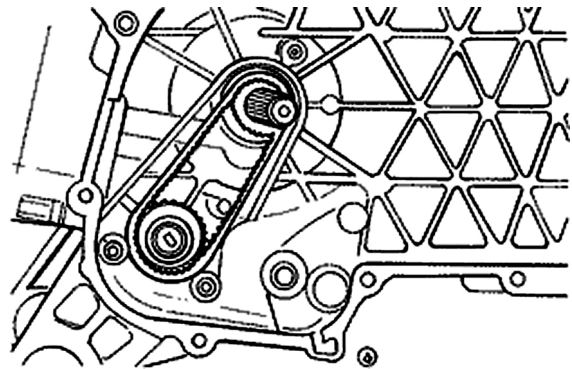

Inspecting the rollers case

- 1) Make sure that the bushing and sliding rings on the mobile pulley are not lined or deformed.
- 2) Check the track where the rollers slide on the contact pulley, there should not be any signs of wear and check the conditions of the belt contact surfaces on the half pulleys (mobile and stationary).
- 3) Make sure that the rollers do not have marked facing on the sliding surfaces and that the metal insert does not protrude from the edges of the plastic cover.
- 4) Make sure that the contact plate sliding blocks are intact.

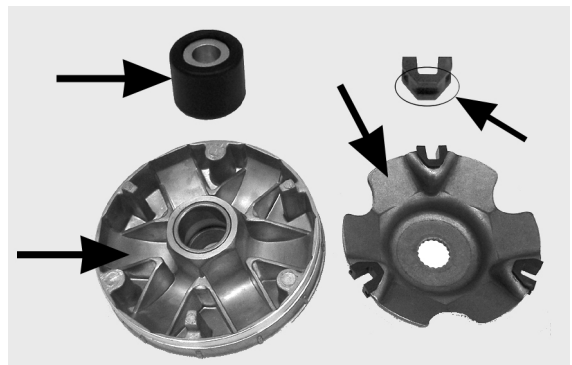

- Check that the internal bronze bushing shown in the figure is not abnormally worn and measure inside diameter «**A**».

- Measure outside diameter «B» of the pulley sliding bushing shown in the figure.

CAUTION

DO NOT LUBRICATE OR CLEAN THE BRONZE BUSHING.

Characteristic

Maximum allowable diameter:

20,12 mm

Standard diameter:

20,021 mm

Sliding pulley brass/ Diameter maximum:

XXX mm

Sliding pulley brass/ Standard diameter:

XXX mm

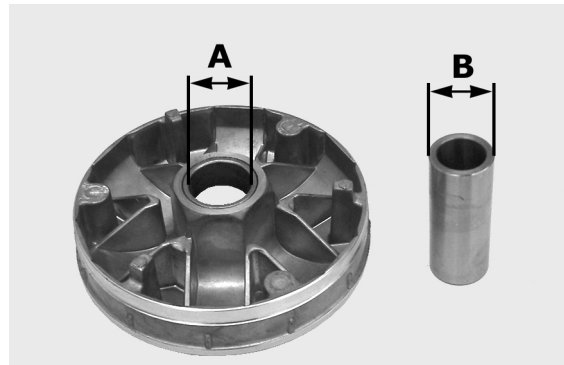

Refitting the driving pulley

- Manually move the mobile driven pulley by pulling it towards the clutch unit and insert the belt keeping the rotation direction of the first assembly.

N.B.

IT IS ALWAYS A GOOD IDEA TO FIT THE BELT SO THAT THE WORDS ARE LEGIBLE IN CASE THE BELT DOES NOT SHOW AN ASSEMBLY DIRECTION.



- Reassemble the unit parts (roller housing unit with bushing, washer, stationary half pulley, belt cooling fan with intake, washer and nut).
 - Tighten the nut to a torque of 20 Nm and then finally tighten 90° with the specific tool preventing rotation of the drive pulley.

N.B.

REPLACE THE NUT WITH A NEW ONE EVERY TIME THE PARTS ARE REASSEMBLED

CAUTION



IT IS VERY IMPORTANT THAT WHEN THE DRIVE PULLEY IS SECURED THAT THE BELT IS FREE INSIDE IT, TO AVOID INCORRECTLY TIGHTENING IT WITH LATER DAMAGE TO THE ENGINE SHAFT MM SCALE.

Specific tooling

020451y Drive pulley stop spanner

Locking torques (N*m)

Tightening torque plus angle $18 \div 20 + 90^\circ$
N.m

End gear

Removing the hub cover

- Drain the oil from the rear hub
- Remove the driven pulley
- Remove the rear brake shoes
- Remove the 5 screws securing the cover to the chassis
- Remove the cover including the wheel axle and extract it
- Remove the intermediate gear with related shear rings

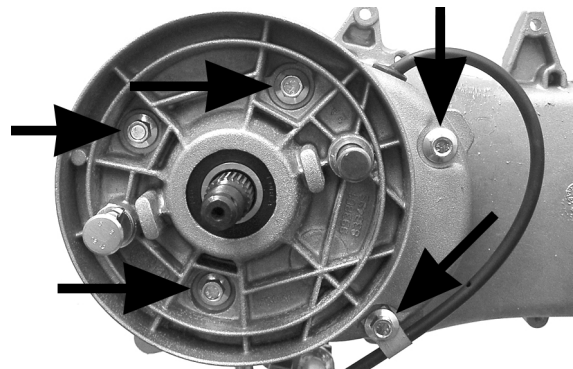

Removing the wheel axle bearings

- Remove the oil guard and seeger ring
- Adequately support the hub cover to avoid damaging the seal surface with the chassis
- Remove the wheel axle bearing with the specific

tool

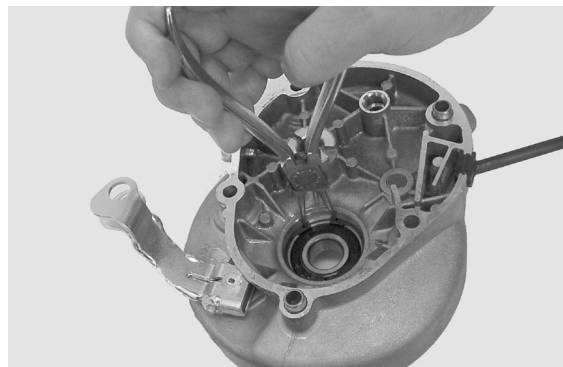
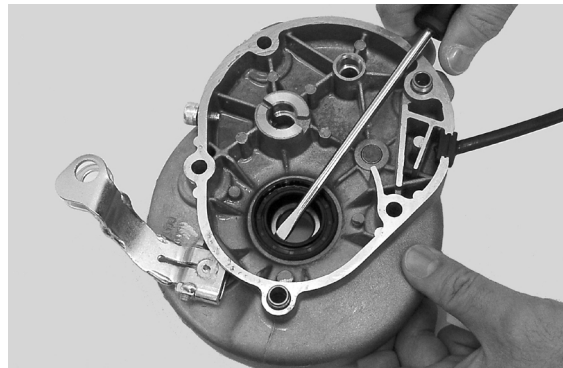
Specific tooling**020363Y 20mm guide****020376Y Handle for punches****020477Y Adapter 37 mm**

Removing the driven pulley shaft bearing

- Remove the seeger ring
- Heat the engine chassis, avoid aiming hot air at the bearing
- Remove the driven pulley shaft with the bearing by hitting it a few time with a mallet



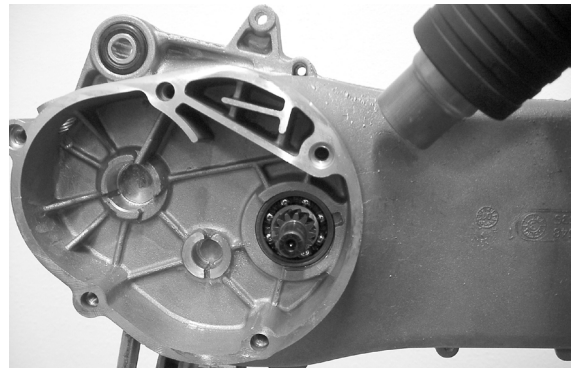

- Remove the bearing from the driven pulley shaft with the specific tool and a gripper

N.B.

USE THE SPECIFIC TOOL FROM THE SIDE WITH A SMALLER INNER DIAMETER

Specific tooling

020452y Driven pulley shaft fitting/removing tube



Inspecting the hub shaft

- Make sure the three shafts are not worn or deformed on the toothed surfaces, bearing and oil guard spans.
- If faults are discovered replace the damaged parts.
- Check the span (A) of the counter gear (wear, lines etc.)
- Check the seat of the pulley shaft: Worn surfaces (B) can indicate irregularity in the seats on the chassis or in the pulley shaft span

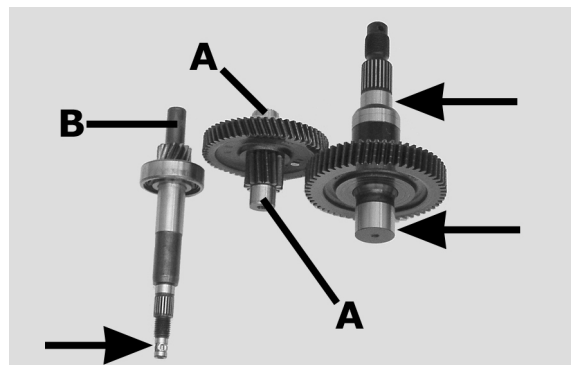

Inspecting the hub cover

- Make sure the coupling surface is not dented or deformed.
- If faults are discovered replace the hub cover.

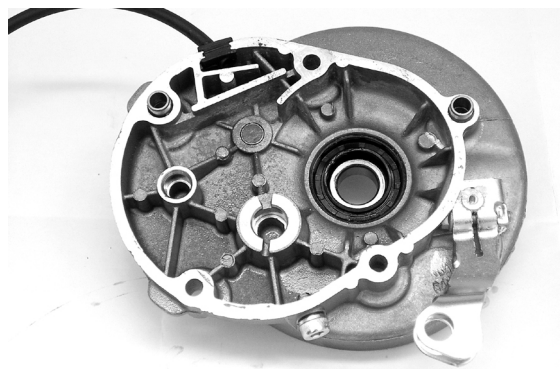

Refitting the driven pulley shaft bearing

- Slightly heat the hub cover and then fit the bearing with the specific drift.
- Fit the circlip with the concave or radial part facing the bearing.

N.B.

FIT THE BALL BEARING WITH THE SHIELD FACING THE OIL SEAL.

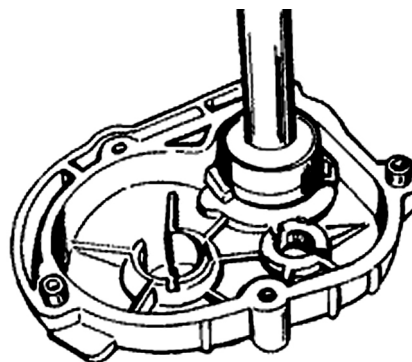

Specific tooling

020151Y Air heater "METABO HG 1500/2"

020376Y Handle for punches

020439Y 17 mm guide

020358y 37 x40 adaptor

- Using the specific tool under the press, support the inner race of the bearing on the outside of the hub cover. Fit the driven pulley shaft.
- Fit the oil seal so it is flush with the cover.

Specific tooling

020452y Driven pulley shaft fitting/removing tube

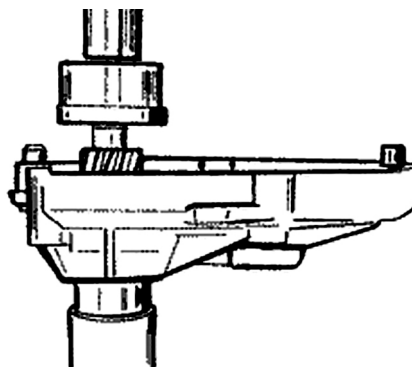

Refitting the wheel axle bearing

- Place the hub cover on a wooden surface
- Heat the hub cover using the heat gun
- Preassemble the bearing on the specific punch using the grease then insert the bearing in its seat.
- Refit the seeger ring and the oil guard using the 42 x 47 adaptor

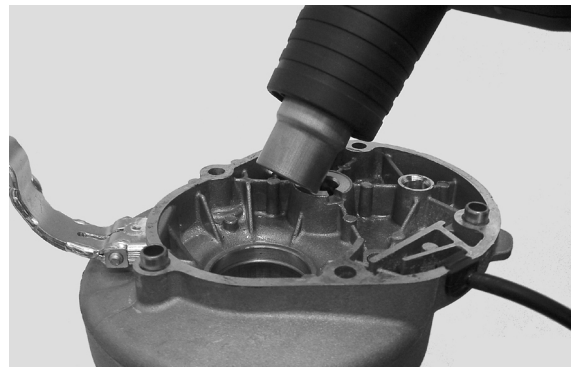

N.B.

POSITION THE OIL GUARD WITH THE SEAL RIM FACING THE INSIDE OF THE HUB.

Specific tooling

020150Y Support for air heater "METABO HG 1500/2"

020151Y Air heater "METABO HG 1500/2"

020376Y Handle for punches

020363Y 20mm guide

020359Y 42 x 47 mm hub bearing fitting adaptor

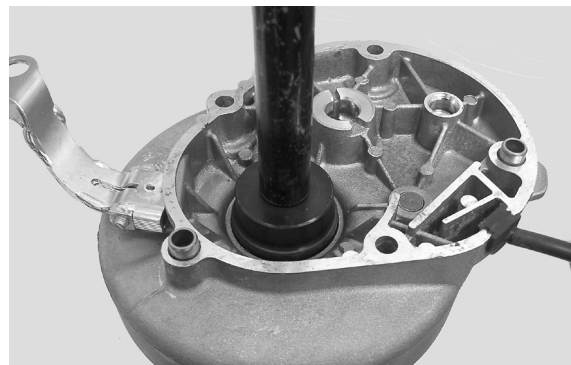
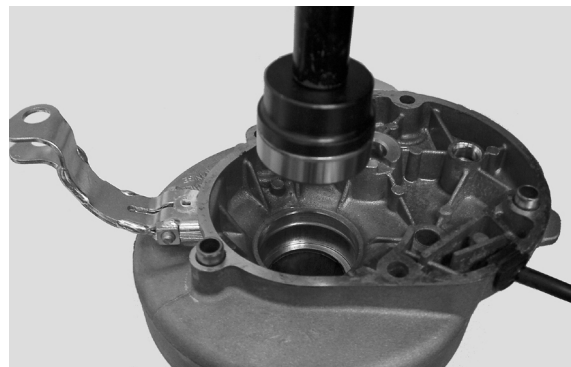

Refitting the hub bearings

- Reassemble the wheel on the cover being careful not to damage the rim of the oil guard seal
- Put a layer of grease on the two intermediate gear shear rings and fit one on the cover so that it does not interfere with the wheel axle gear when inserting the countershaft



Refitting the ub cover

-
- Apply a product recommended for surfaces to the hub cover and refit it on the chassis
 - Install the 5 screws and tighten to the prescribed torque.

N.B.

BEFORE FITTING A NEW GASKET, REMOVE ANY RESIDUES OF THE OLD GASKET FROM THE MATEING SURFACES OF THE HUB COVER AND THE CRANKCASE HALF.



Recommended products

Loctite 510 Packing fluid

Packing

Locking torques (N*m)

Tightening torque 24 - 26

Flywheel cover

Cooling hood

- Remove the 4 fixings shown in the figure
- Remove the fan cover

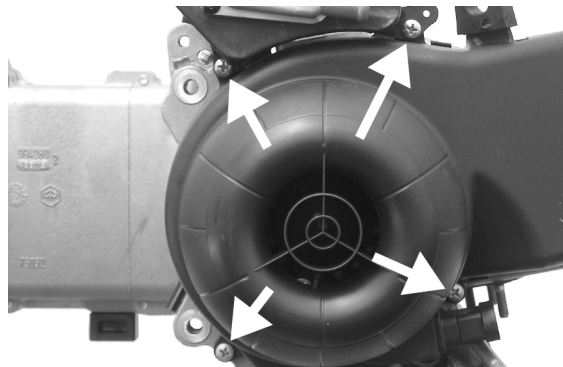

- Remove the oil line retaining zip tie from the cooling hood
- Remove the two screws shown in the picture

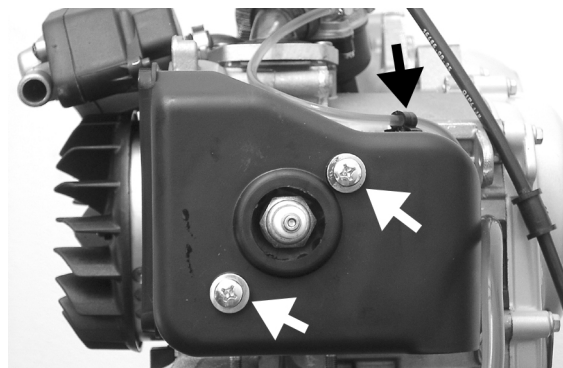

Cooling fan

- Remove the three fastenings shown in the figure.

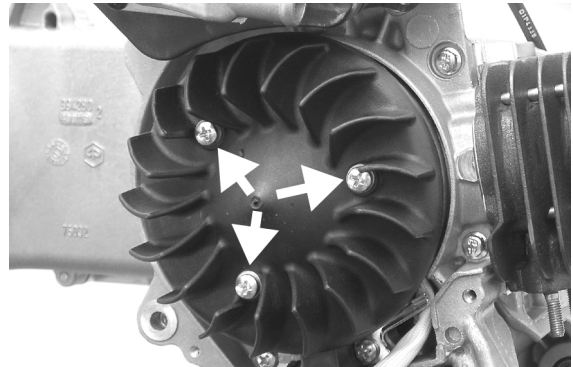

Removing the stator

- Remove the stator 3 implantations indicated in photo
- Remove the pick-up 2 implantations indicates in photo
- Remove the stator complete with wiring

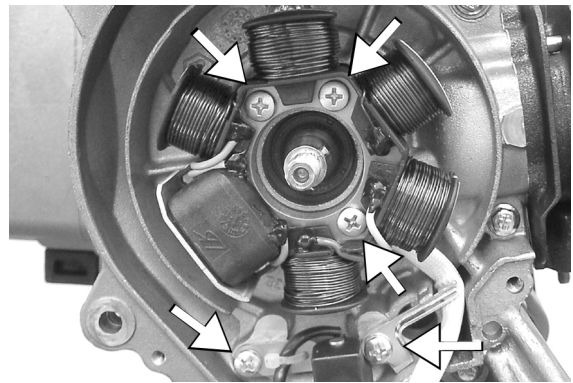

Refitting the stator

- Fit the stator and the flywheel by following the reverse procedure to the removal. Tighten the fastenings with the prescribed torque.

N.B.

THE PICK-UP WIRE MUST BE POSITIONED SO THAT IT TOUCHES THE CAST TAB ON THE CRANK-CASE. THIS WILL PREVENT IT FROM BEING CRUSHED BY THE FAN COVER ASSEMBLY.

Locking torques (N*m)

Pick-up screws 3 ÷ 4 Stator screws 3 ÷ 4

Flywheel and starting

Removing the starter motor

Remove the fixings shown in the picture

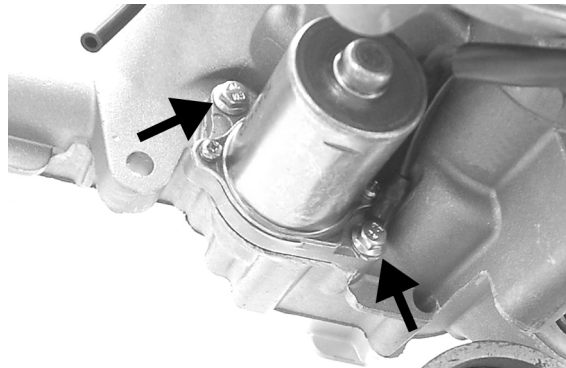

Removing the flywheel magneto

- Lock the flywheel using the compass spanner.
- Remove the nut.

CAUTION

USING A COMPASS SPANNER OTHER THAN THE ONE PROVIDED CAN DAMAGE THE STATOR COILS.

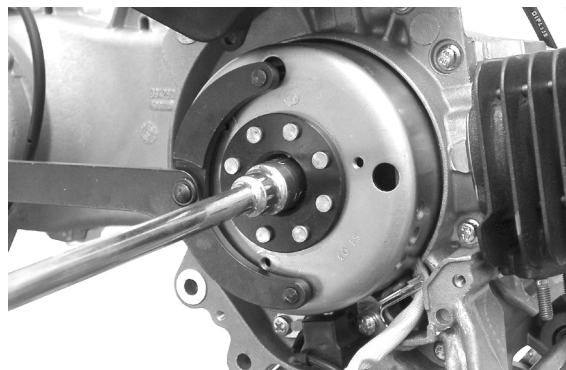

- Extract the flywheel with the specially designed extractor.

Specific tooling

020565Y Compass flywheel stop spanner

020162y Flywheel extractor

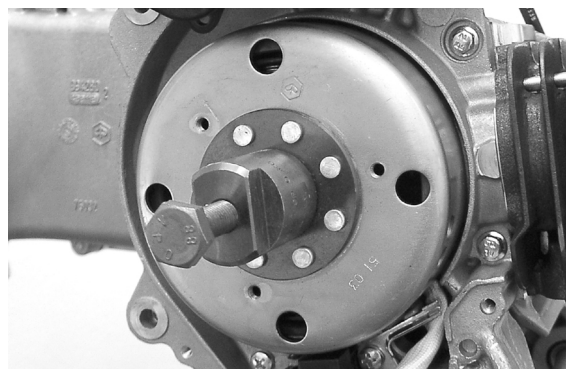

Inspecting the flywheel components

- Check the flywheel for any distortion that might cause rubbing on the stator and the pick-up.

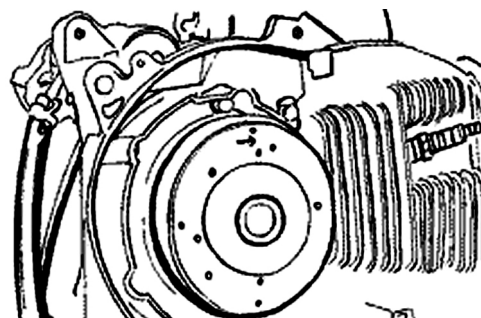

Refitting the flywheel magneto

- Fit the flywheel taking care to properly insert the key.
- Tighten the flywheel locknut with the prescribed torque.
- Check that the pick-up air gap is 0.5 - 0.6 mm
No adjustment of the air gap is necessary when fitting the pick-up.

A different air gap denotes distortion of the pick-up support.

N.B.

A CHANGE IN THE AIR GAP MAY ALTER THE SPARK ADVANCE AND CAUSE KNOCKING, ETC.

Locking torques (N*m)

Flywheel nut 40 ÷ 44 N.m



Refitting the starter motor

- Fit a new O-ring on the starter motor and lubricate it.
- Install the starter motor on the crankcase and tighten the two screws with the prescribed torque.

N.B.

FIT THE REMAINING PARTS AS DESCRIBED IN THE CHAPTERS CYLINDER, CYLINDER HEAD, VALVE GEAR, LUBRICATION, FLYWHEEL AND TRANSMISSION.

Locking torques (N*m)

Starter motor screws 11 ÷ 13

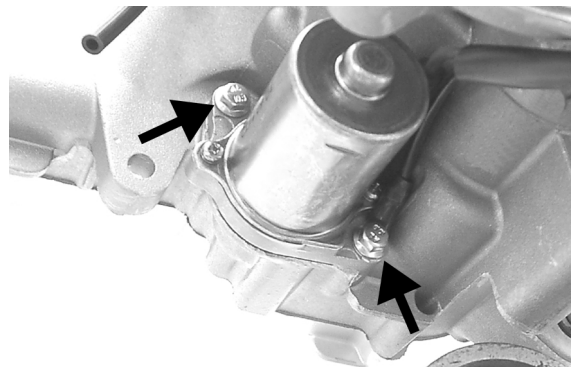

Cylinder assy. and timing system

Removing the intake manifold

Using the TORX spanner, remove the 2 intake

manifold fixing screws

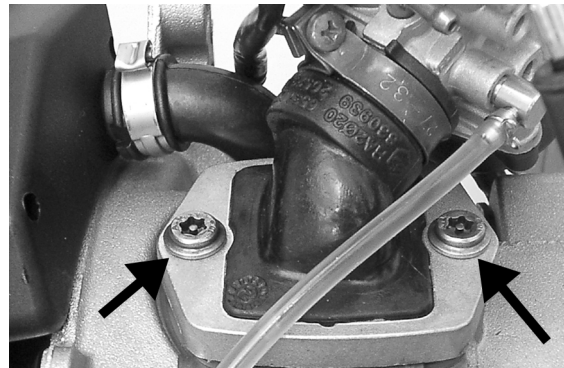

Removing the cylinder head

Remove the four nuts shown in the picture

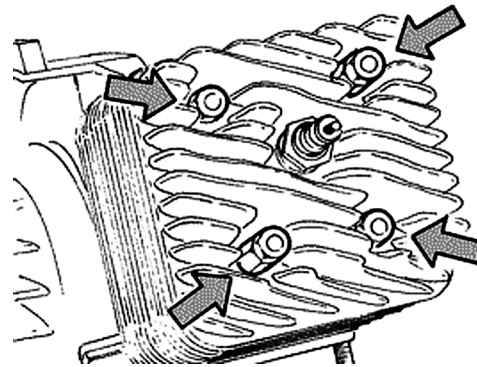

Removing the cylinder - piston assy.

Carefully remove the cylinder

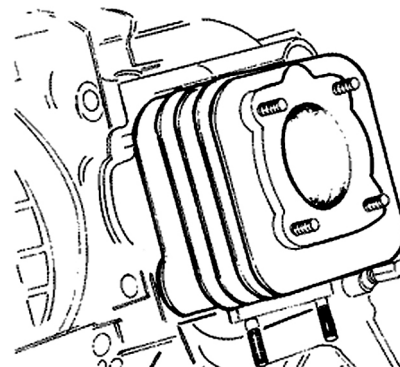

Remove the split rings and the wrist pin

CAUTION

ALWAYS REPLACE THE WRIST PIN SPLIT RINGS WITH NEW ONES

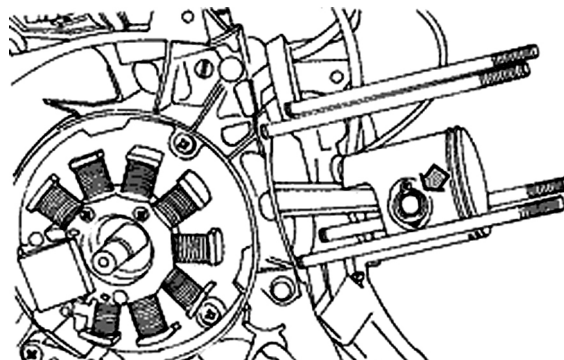

Inspecting the small end

- Using an inside micrometer, measure the small end diameter

N.B.

IF THE SMALL END DIAMETER EXCEEDS THE MAXIMUM ALLOWABLE VALUE, OR IF IT SHOWS SIGNS OF WEAR OR OVERHEATING, PROCEED TO REPLACE THE CRANKSHAFT AS DESCRIBED IN THE CHAPTER "CRANKCASE AND CRANK-SHAFT".

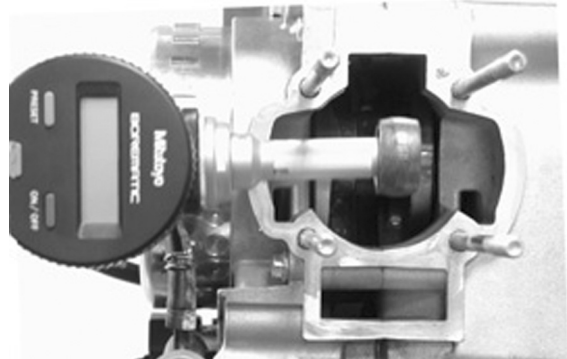

Characteristic

Standard diameter

17 +0,011-0,001

Max. allowable diameter

17,060

Inspecting the wrist pin

- Check the wrist pin external diameter using a micrometer

Characteristic

Wrist pin: standard diameter

12 +0,005 +0,001 mm

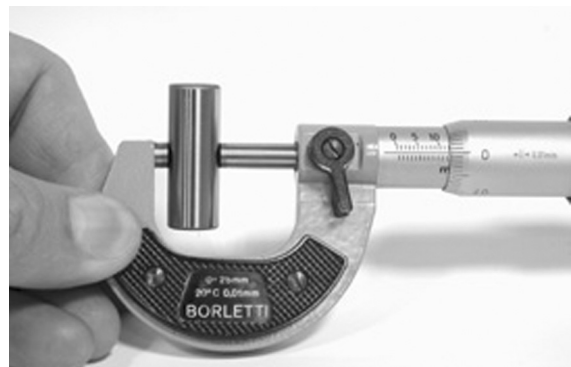

Inspecting the piston

- Using a suitable instrument measure the piston diameter

- Evaluate the piston-wrist pin fitting clearance

Characteristic

Wrist pin housing: standard diameter

12 +0,007 +0,012

Wrist pin housing: standard tolerance

0,002 ÷ 0,011 mm



-
- Measure the external diameter of the piston according to a direction orthogonal to the pin axis
 - Carry out the measurement at the location shown in the figure
- To classify the cylinder-piston mating, check the appropriate table

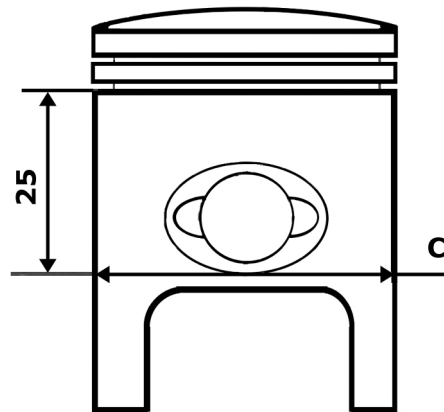

See also

[Cylinder - piston assy.](#)

Inspecting the cylinder

- Check the cylinder does not show signs of seizures. If it does proceed by replacing it or performing a grinding operation befitting the available oversize pistons
- Using an appropriate device, measure the internal cylinder diameter in the directions shown in the figure
- Check the mating surface with the head is free from wear or deformations To classify the cylinder-piston mating, check the appropriate table

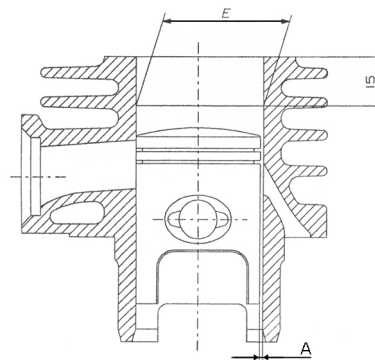

See also

[Cylinder - piston assy.](#)

Inspecting the piston rings

- Alternatively insert the two piston rings inside the cylinder
- Insert the piston rings in the direction orthogonal to the cylinder axis, using the piston to push them through.
- Measure the rings gap using a feeler gauge as shown in the picture.
- If the measured values exceed those shown in the table, proceed by replacing the rings.

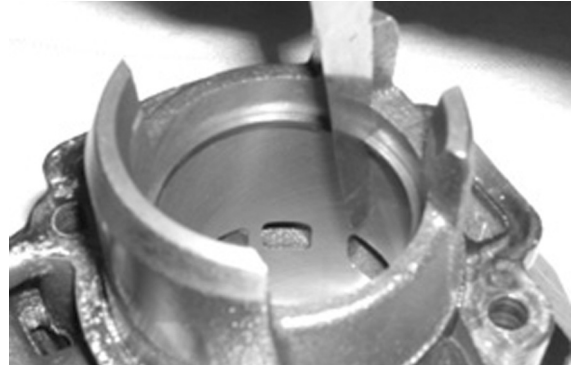

Removing the piston

- Position the piston ring inside part 1 with its opening coinciding with the arrow shown on the tool.
- Push part 2 through part 1 as far as it will go and hence extract part 2.
- Insert part 3 inside part 1, position the assembly in the piston ring housing and push part 3 home.

N.B.

REFIT THE REMAINING COMPONENTS FOLLOWING THE OPERATIONS FOR THEIR REMOVAL IN THE REVERSE ORDER.

Specific tooling

020166y Piston rings fixing tool

Locking torques (N*m)

Cylinder head lock nuts 10 ÷ 11 N·m

- Use new split rings for the wrist pin.
- Replace the cylinder base gasket with a new one.
- Before proceeding with the reassembly carefully clean all surfaces.
- Lubricate components with two-stroke oil when refitting piston and cylinder.

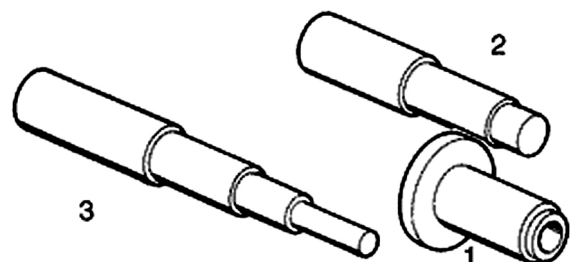

CAUTION

POSITION THE ARROW STAMPED ON THE TOP OF THE PISTON TOWARDS THE EXHAUST PORT. THE WRIST PIN SPLIT RINGS MUST BE POSITIONED ON THE PISTON USING THE SPECIAL TOOL.

Recommended products**Selenia Hi Scooter 2 Tech Oil**

Recommended oil

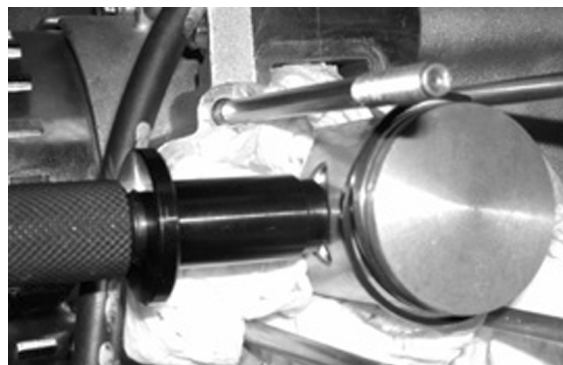
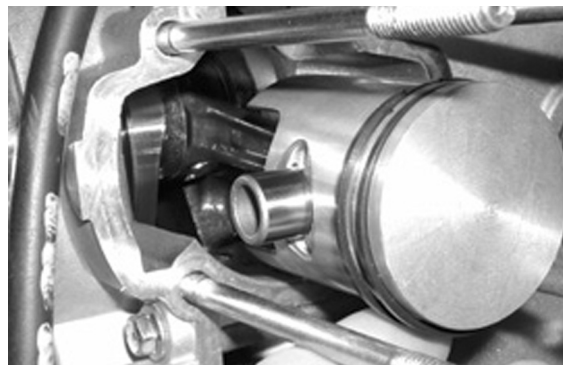

Inspecting the timing system components**CAUTION**

CHECK THE LEAK TIGHTNESS OF THE REED VALVE ASSY.; NO LIGHT BE VISIBLE BETWEEN VALVE AND HOUSING.

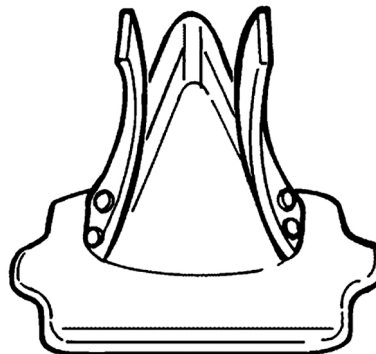

Crankcase - crankshaft

Splitting the crankcase halves

Remove the eight crankcase fasteners.

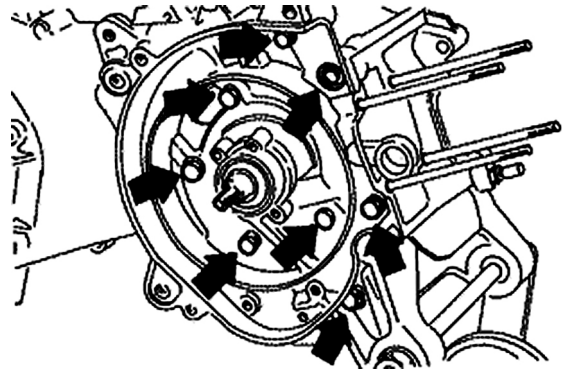

Install the special plate on the flywheel-side half-crankcase and proceed by splitting the two halves.

Specific tooling

020163y Crankcase splitting plate

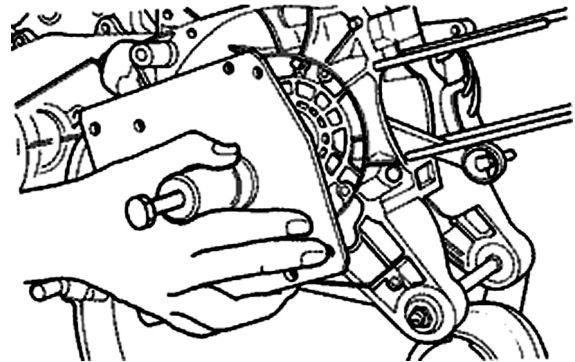

Removing the crankshaft

- Install the special tool onto the transmission-side half-crankcase using four M6 screws of adequate length.

- Remove the crankshaft from the transmission-side half-crankcase.

Specific tooling

020163y Crankcase splitting plate

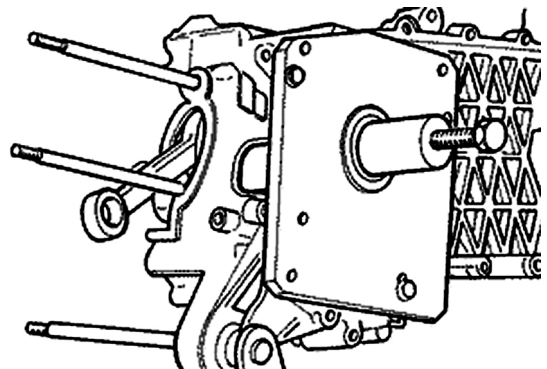

Removing the crankshaft bearings

The bearings may remain attached either to half-crankcase or crankshaft, indifferently.

- Using the special tool provided, remove only the bearings attached to the engine.

N.B.

THE HALF RINGS MUST BE FITTED ONTO THE BEARINGS WITH THE AID OF A MALLET.

Specific tooling

004499y001 Bearing extractor fitted with parts

004499y006 Bearing extractor fitted with parts

004499y002 Bearing extractor fitted with parts

004499y007 Half rings



Using the special tool, remove any bearing which remained on the crankcase.

Specific tooling

001467Y007 Bell for bearings external Ø 54 mm

001467Y006 20-mm pliers

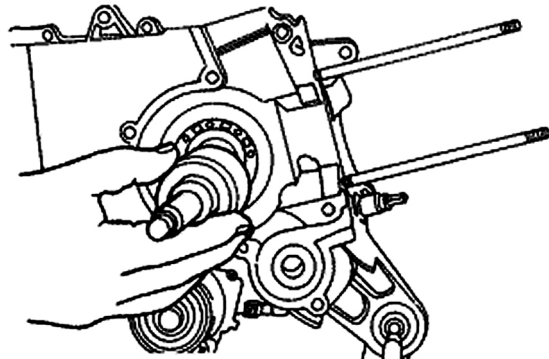

Refitting the crankshaft bearings

Heat the bearings in oil at approx. 100°C and fit them onto the crankshaft with the aid, if necessary of tube section acting directly on the internal ring of the bearing.

Specific tooling

020265y Bearing fitting stand

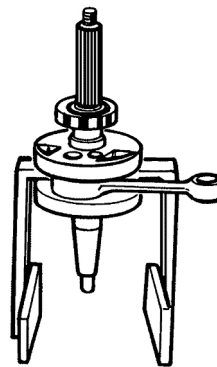

Inspecting the crankshaft alignment

Using the appropriate specific tools, check the eccentricities of the surfaces of diameters

«A»-«B»-«C» are within 0.03 mm (top reading limit for the dial gauge clock); check also the eccentricity of diameter «D», for which a maximum

misalignment of 0.02 mm is allowed. In the event that the eccentricities are not too far off the prescribed values, **straighten** the crankshaft by acting with a wedge in between the counterweights or by using vice (with aluminium mouth guards) according to your needs.

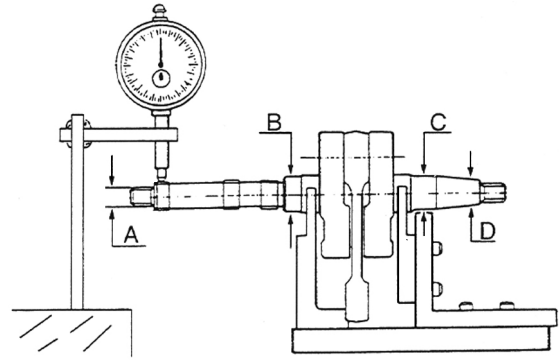

Specific tooling

020335Y Magnetic stand and comparator

020074Y Crankshaft aligning tool

Refitting the crankshaft

- Rest the transmission-side half-crankcase on two wooden supports.
- Using a heat gun, heat the bearing housing up to approx. 120°.

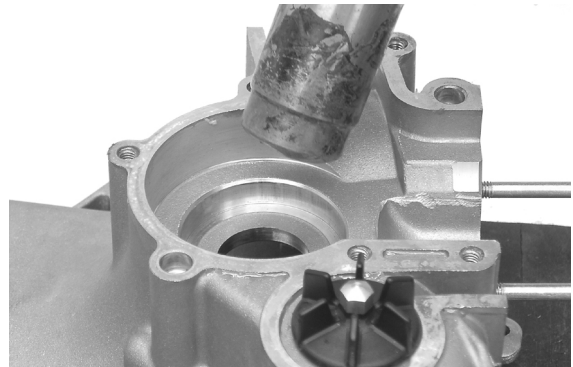

- Insert the crankshaft and push it in as far as the bearing will go.

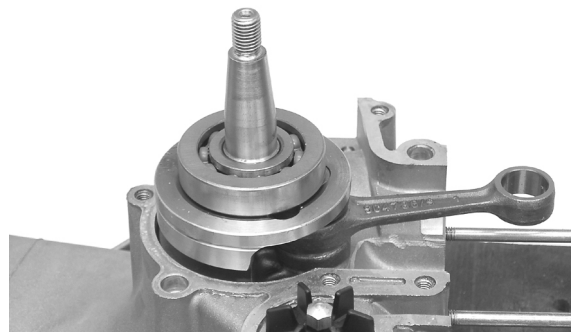

- Let the half-crankcase temperature settle with that of the crankshaft.
- Reinstall the crankcase splitting plate **WITHOUT** installing the crankshaft protection.
- During the reassembly process keep the centre thrust screw loose.

- Tighten the four fixing screws and then loosen them with the same angle (e.g. 90°)
- When the temperature has settled manually preload the tool's thrusting screw until the ball bearing play disappears.

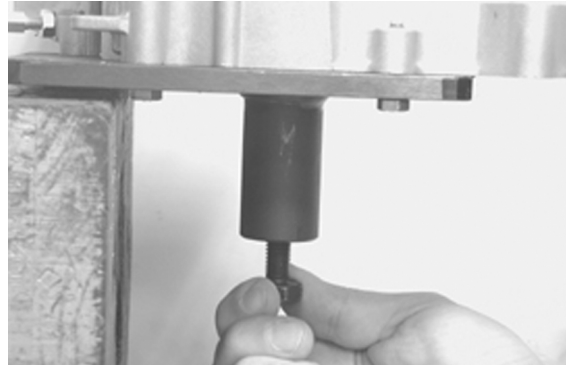

Specific tooling

020163y Crankcase splitting plate

Refitting the crankcase halves

- Prepare the mating plane by applying a thin layer of LOCTITE 510, after cleaning the surface with an adequate solvent (e.g. acetylene trichloride).
- Heat the flywheel-side half-crankcase using a heat gun.

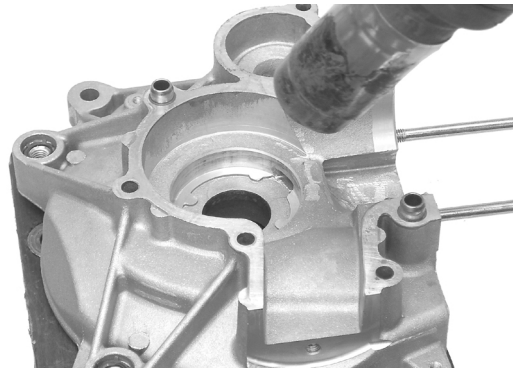

Recommended products

Loctite 510 Packing fluid

Packing

- Keeping the transmission-side half-crankcase in horizontal position, vigorously and accurately insert the flywheel-side half-crankcase.
- Insert at least 3 fixing screws and tighten them quickly.
- Insert the other 5 screws and tighten them at the prescribed torque.

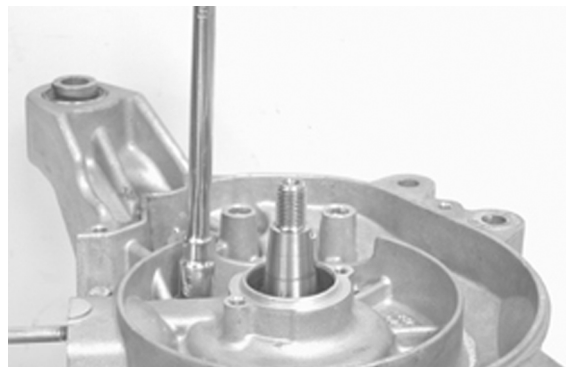

Locking torques (N*m)

Crankcase fixing screws 11 - 13

- Move the crankcase splitting plate backwards as shown in the figure.
- Install the special magnetic mounting with its dial gauge, at the end of the crankshaft.
- Check the crankshaft axial play.

- If the measurements do not match those prescribed, repeat the crankshaft reassembly operation.

Specific tooling

020335Y Magnetic stand and comparator

Characteristic

Axial play with warm crankcase

0,10 ÷ 0,12 mm

Axial play with cold crankcase

0,06 ÷ 0,08 mm

Limit value with cold crankcase

0,02 ÷ 0,03 mm

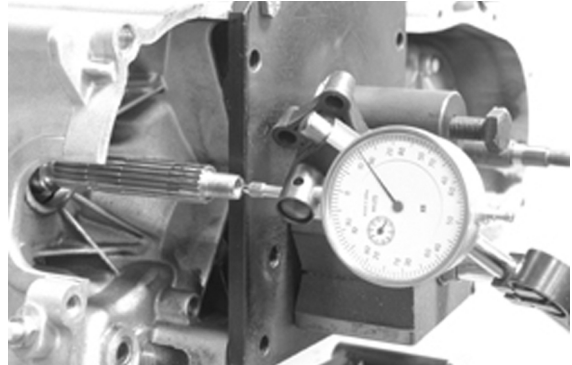

Lubrication

Crankshaft oil seals

Refitting

- Install a new flywheel-side oil seal using the puncher from the special tool.
The flywheel-side oil seal may be recognised for having a smaller diameter.

N.B.

THE SPECIAL TOOL MAY NOT BE USED WHEN THE WOODRUFF KEY IS FITTED

Specific tooling

020340Y Punch for fitting oil guard magneto and transmission

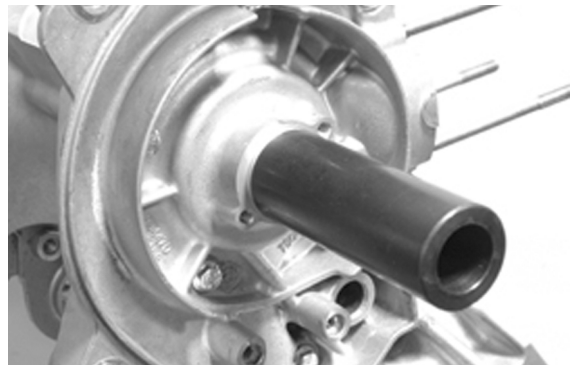

- Install a new transmission-side oil seal using the special tool fitted with adapter ring.
The transmission-side oil seal may be recognised by its larger diameter.

Specific tooling

020340Y Punch for fitting oil guard magneto and transmission



Oil pump

Removal

Remove the two screws shown in the figure

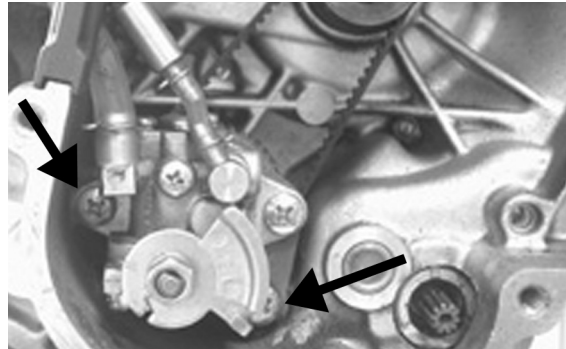

Remove the fairlead from the crankcase, as indicated in the figure.

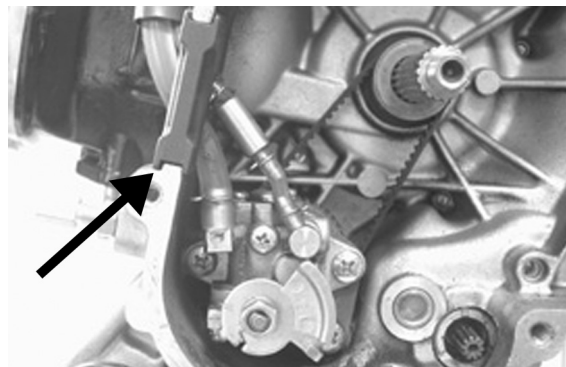

Refitting

For the reassembly follow the removal operations in the reverse order.

After the reassembly, it is recommended to bleed the system by acting upon the screw shown in the picture.

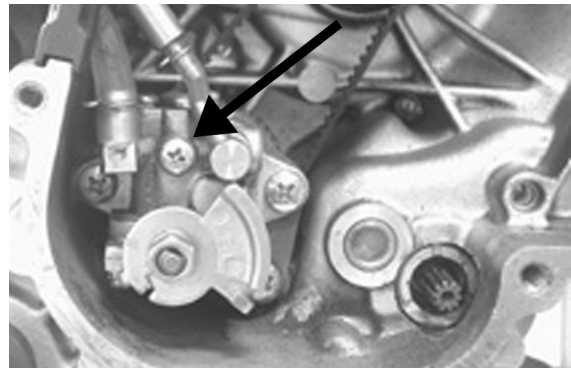

Fuel supply

- Disconnect the fuel feed pipe and the vacuum pipe from the carburettor.
- Ensure that no fuel is leaking from the pipes.
- Close the fuel outlet.
- Using the MITYVAC pump, apply a 0.1 bar vacuum to the cock.
- Ensure that the vacuum does not change, and that no fuel is leaking.
- Reconnect the vacuum pipe to the manifold.
- Position the fuel pipe so that its outlet is on the same level as the cock.
- Make the engine turn by operating the starter motor for five seconds with the carburettor in the idle position.
- Gather the fuel in a graduated burette.

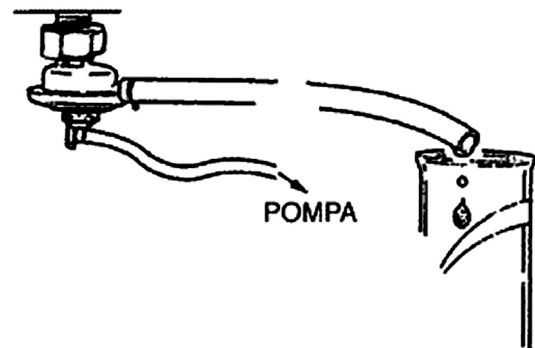

N.B.

THE MEASUREMENT MAY BE ALTERED BY AN UNSUITABLE ENGINE SPEED OR BY INCORRECT POSITIONING OF THE PIPE. IN THAT CASE, A REDUCED FUEL DELIVERY IS GENERALLY OBTAINED. THE VACUUM HOLE ON THE MANIFOLD HAS AN INTENTIONALLY REDUCED CROSS-SECTIONAL AREA IN ORDER TO IMPROVE THE VACUUM PULSES AND ENSURE CONSTANT DELIVERY OF THE COCK.

Specific tooling

020329Y Pump MITYVAC

Characteristic**Minimum delivery**

20 cc

-
- Drain the fuel from the tank.
 - Remove the fuel delivery pipe and the vacuum pipe.
 - Release the clamp and remove the cock.
 - Clean the tank and the cock filter with a suitable solvent.
 - Refit the cock taking care to verify the presence of the O-ring.
 - Turn the cock in the same direction as before the removal and then tighten the clamp.

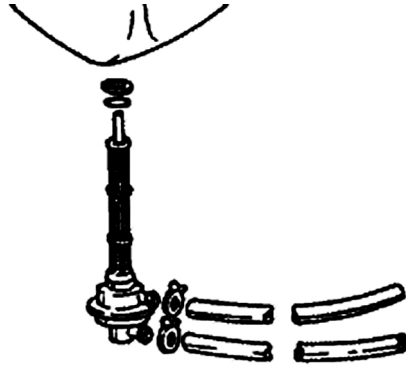
**N.B.**

THE FILTER CAN BE SCREWED OFF THE COCK TO FACILITATE THE CLEANING.

INDEX OF TOPICS

SUSPENSIONS

SOSP

Front suspension

This section describes the operations which can be carried out on the suspensions.

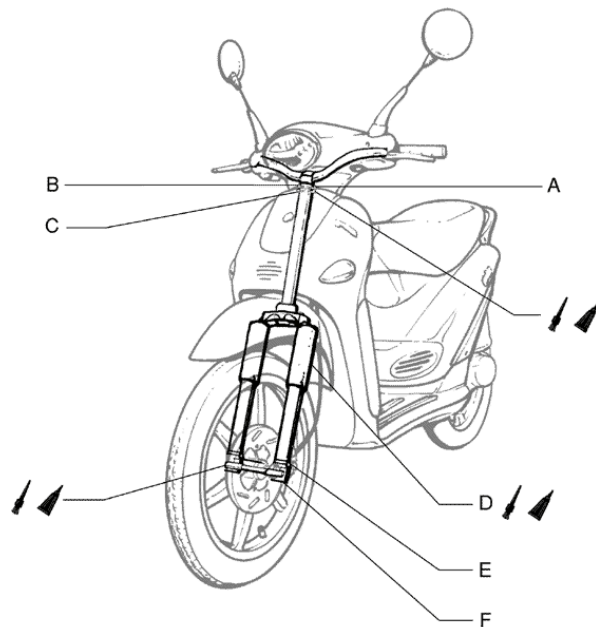

Front

Front wheel hub overhaul

Ball bearings to hub

- Fit the spacer
- Fit the ball bearings and bushes and position the seal rings.

WARNING

PRIOR TO REASSEMBLY, LUBRICATE WITH JOTA 3 F.S. GREASE IN THE AREAS MARKED WITH THE ASTERISK.

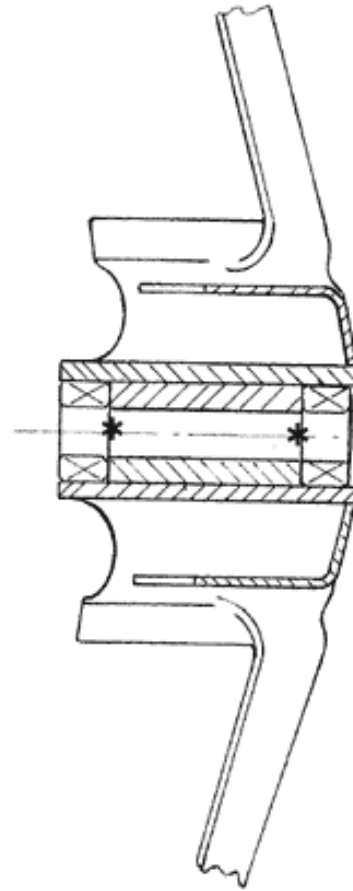

Handlebar

Removal

Disassembling the handlebar

- Before proceeding, remove the handlebar fairing.
- After detaching flexible transmission cables and disconnecting electrical terminals, loosen the clamp securing the handlebar to the steering tube
- Check all components and replace any damaged or defective parts.

N.B.

IF YOU ARE REMOVING THE HANDLEBAR ONLY SO THAT YOU CAN THEN REMOVE THE STEERING ASSEMBLY, SIMPLY ALLOW THE HANDLEBAR TO

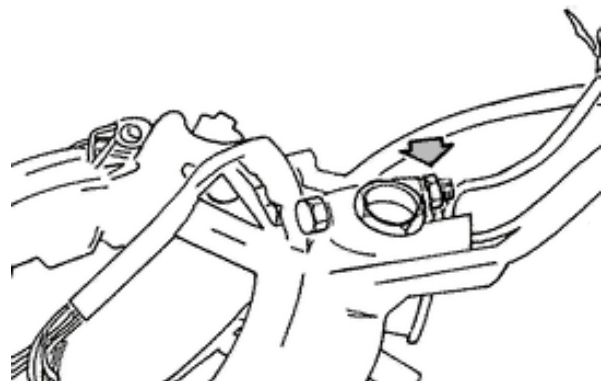

TIP OVER THE FRONT OF THE SCOOTER, TAKING CARE THAT FLEXIBLE TRANSMISSION CABLES ARE NOT DAMAGED.

Front fork

Overhaul

O-ring renewal and rod disassembly

- Disassemble the wheel spindle.
- Remove lower screw (1).
- Allow the fork oil to drain out.
- Withdraw the rod.
- Renew the O-rings (3 - 4).
- Insert the rod and refit lower screw (1).
- Remove upper screw (2).
- Pour in 30 cc \pm 1 of "FORK PG" (SAE 20W fork oil)
- Reassemble all parts.

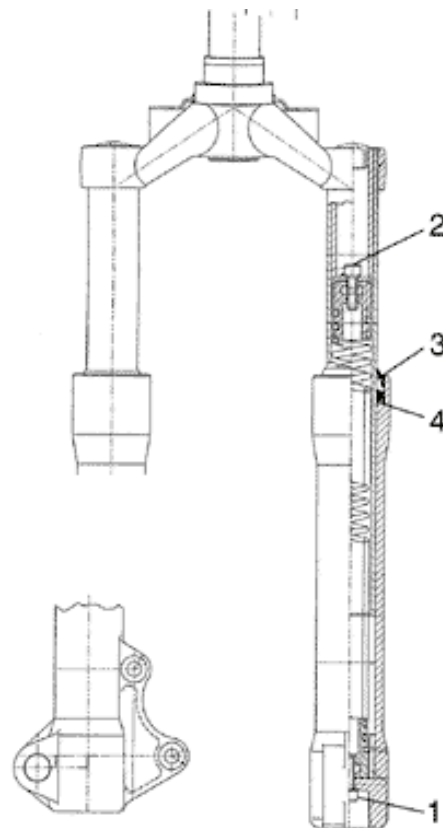

Locking torques (N*m)

Lower screw tightening torque: 20 \div 25 N·m

Upper screw tightening torque: 20 \div 25 N·m

Steering column

Refitting

Lower and upper bearing races to frame

Lower and upper bearing races to frame

**LOWER AND UPPER BEARING RACES
TO FRAME**

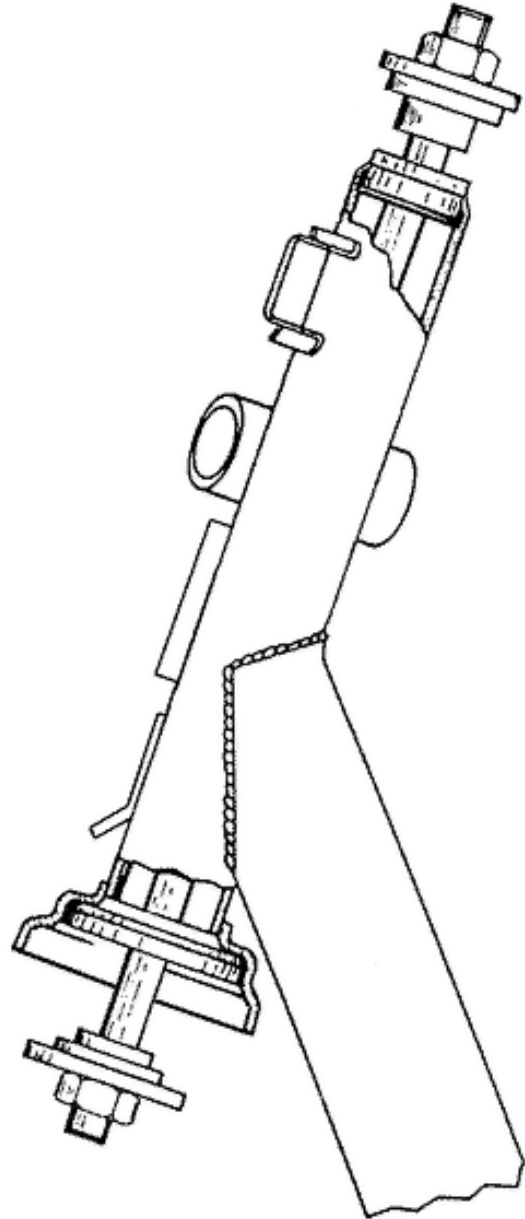

Steering bearing

Steering collar

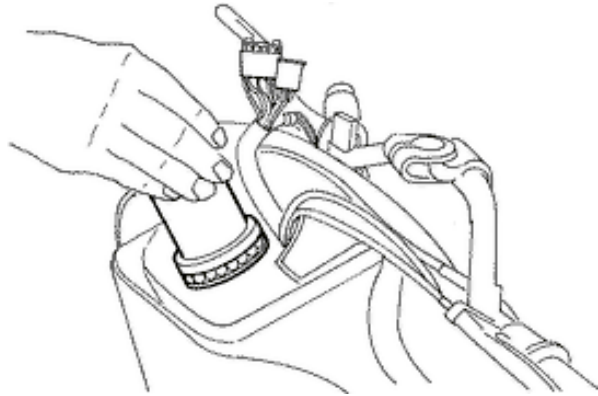
Steering collar

Steering bearing upper race

- Lubricate race and balls with **Z2** grease.
- Tighten to the specified torque and then rotate the tool through 80° - 90° in an anticlockwise direction.

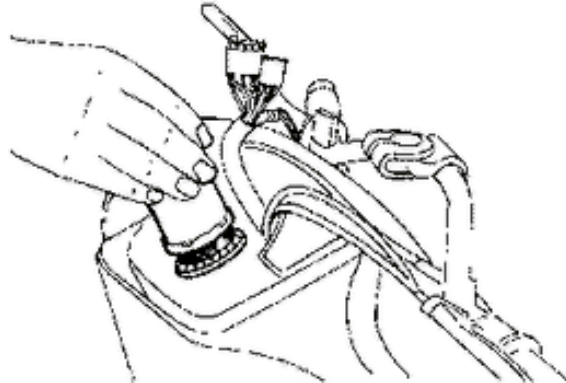

Removal**Lower and upper races from frame**

- To remove the bearing races from the frame use the relative special tool as shown in the figure.

N.B.

THE LOWER BEARING RACE CAN BE PRISED OFF BY LEVERING IT WITH A SCREWDRIVER OR SIMILAR.

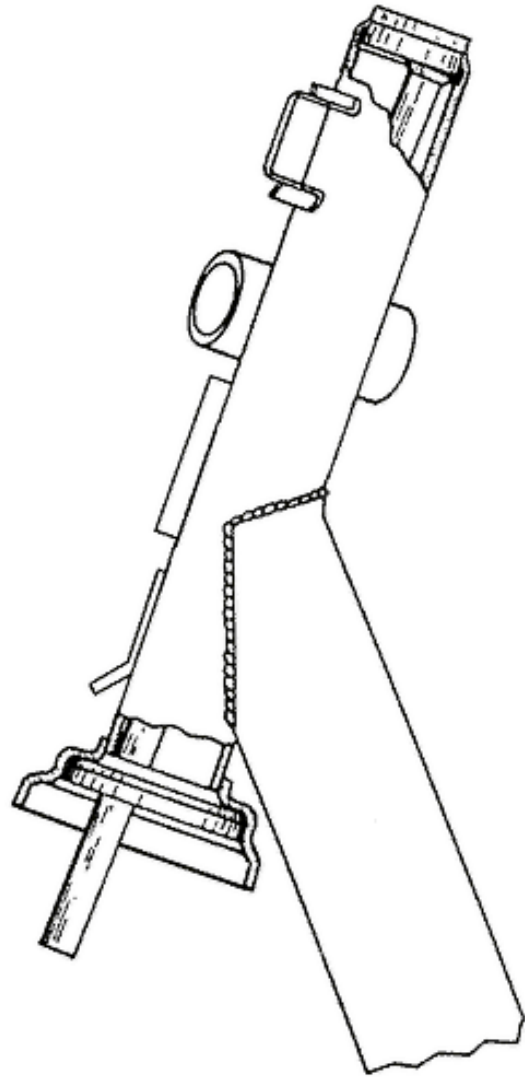
**LOWER AND UPPER RACES FROM FRAME**

Upper bearing washer and race

- Remove the upper race and then lean the vehicle over to one side in order to remove the steering tube, after having removed the spray guard and brake calliper.

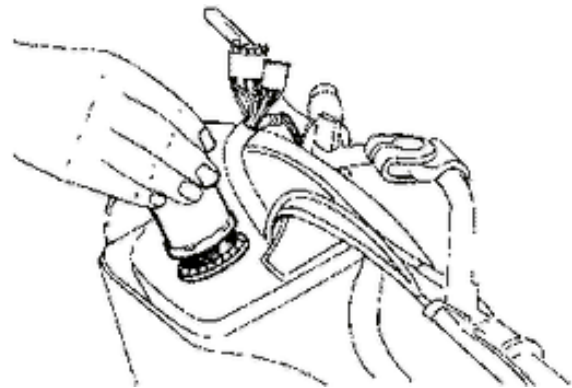

Rear

Removing the rear wheel

- Prise off the hub cap by levering against the brake drum with a screwdriver
- Straighten the split pin and remove the cap.
- Unscrew the wheel spindle nut and remove the wheel.
- On reassembly, tighten the spindle nut to the prescribed torque.

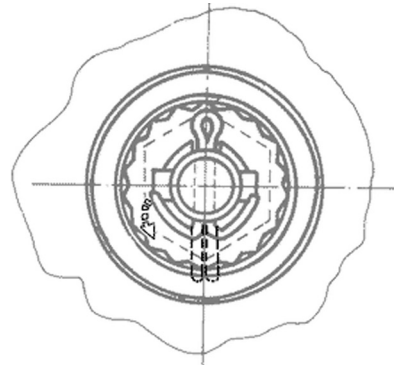

WARNING

USE A NEW SPLIT PIN.

Refitting the rear wheel

- Refit the parts as directed for disassembly but in the reverse order, tighten the wheel nut to the prescribed torque.

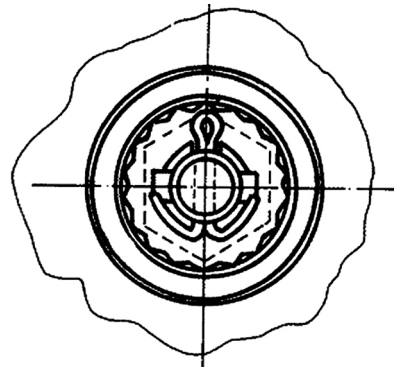

WARNING

BEND OVER THE SPLIT PIN ENDS AS SHOWN IN ORDER TO ELIMINATE PLAY BETWEEN THE CAP AND WHEEL SPINDLE.

Locking torques (N*m)

Rear wheel axle 104 ÷ 126

Shock absorbers

Removal Absorber

- To replace the shock absorber, remove the rear cover and the battery access door. This action exposes the shock absorber/frame fixing nut, which must now be removed. Subsequently, remove the shock absorber-engine pivot pin.
- At the time of reassembly, tighten the shock ab-

sorber-frame fixing nut and the shock absorber/engine pivot pin to the prescribed torques.

Locking torques (N*m)

Shock absorber/engine pivot pin 33 ÷ 41 N·m

Shock absorber/frame nut 20 ÷ 25 N·m

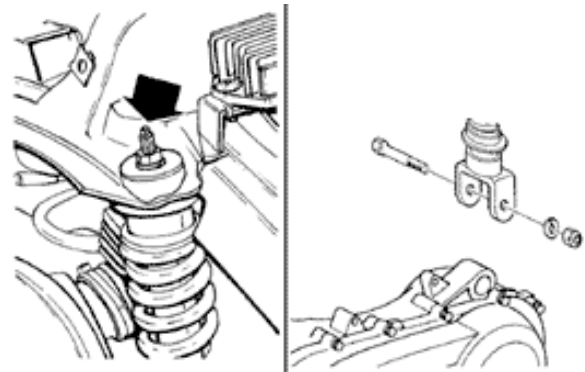

Centre-stand

Expelling stand pivot pin from bracket

- Disassemble the stand bracket from the engine.
- Drill to a depth of 5 mm from one side in order to remove pivot pin «P».

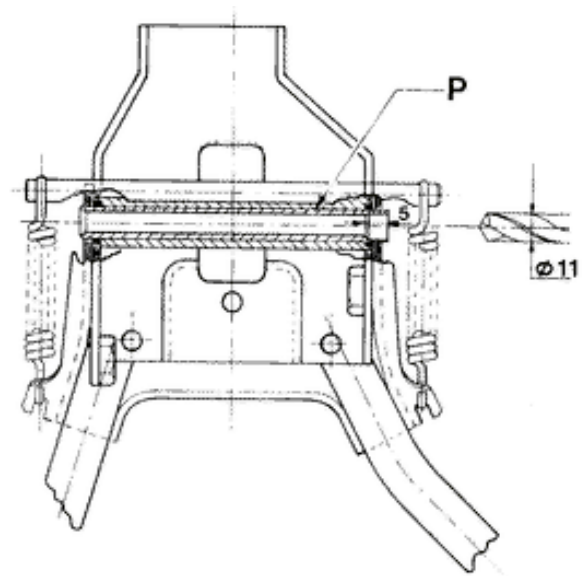

Assembly and staking of stand pivot pin to bracket

- Stake the end of pin «P» using the two punches shown in the figure.
- The stand should turn freely on its pivot after this operation.

N.B.

REASSEMBLE THE STAND USING NEW O-RINGS AND A NEW PIN. GREASE THE SPRING ATTACHMENT POINTS AND THE PIN.

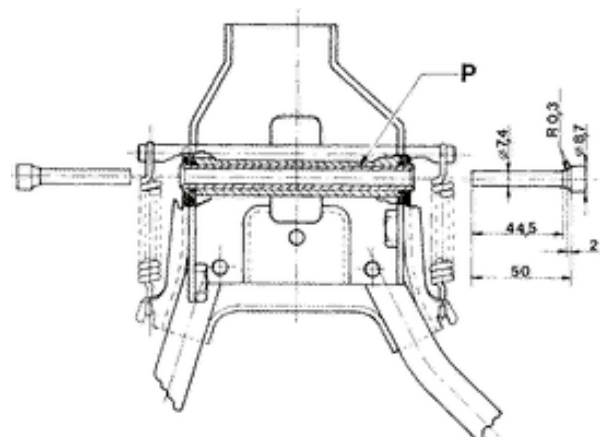

Changing the complete stand

- Remove the 2 screws shown in the figure.
- On reassembly, tighten to the prescribed torque.

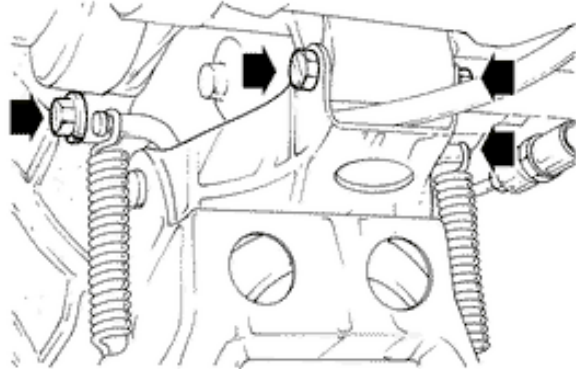
Locking torques (N*m)**Stand bracket screws $18,5 \div 19$ N·m**

INDEX OF TOPICS

BRAKING SYSTEM

IMP FRE

After removing the muffler and wheel proceed as follows:

- 1.Remove the shoe spring using the specific pliers.
- 2.Remove the shoes using a lever.
- 3.Fit the new shoes using a mallet and hitting lightly.
- 4.Hook the spring using the specific pliers.

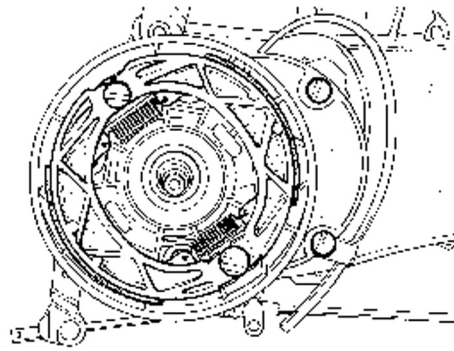

Specific tooling

020325y Pliers for brake-shoe springs

Rear brake calliper

Refitting

Insert the following parts into the calliper half bodies:

- sealing rings (1-2);
- pistons (3);
- fit O-ring seal (4) in one of the pump bodies.
- Couple the inner and outer bodies by means of the coupling bolts. Fit the pads and bleed air from the system (see previous paragraphs).
- Position the caliper on the disc and fasten it to the support, tightening the bolts.
- Secure the tube connection to the caliper with the required torque.
- Before reassembly, the parts must be perfectly clean and **bear no traces of oil, diesel fuel, grease**, etc.. They must therefore be washed thoroughly in denatured alcohol before proceeding.

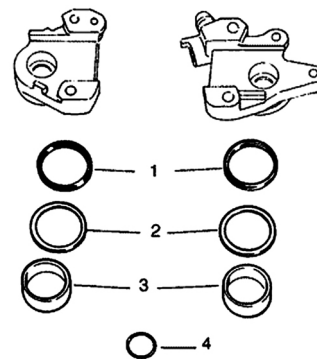

Immerse the seals in brake fluid; the use of protective agent PRF1 is tolerated.

CAUTION

RUBBER PARTS MUST NOT BE LEFT IN ALCOHOL FOR MORE THAN 20 SECONDS. AFTER WASHING, DRY THE PARTS WITH COMPRESSED AIR AND A CLEAN CLOTH

Locking torques (N*m)

**Screw fixing the caliper to the support 20 ÷ 25
Calliper to tube connection 8 ÷ 12 Nm**

Front brake calliper

Removal

- Disconnect the brake tube and allow the fluid to flow into a container.
- Remove the screws shown in the figure.
- When reassembling, tighten the nuts to the prescribed torque.
- Bleed air from the brake circuit.

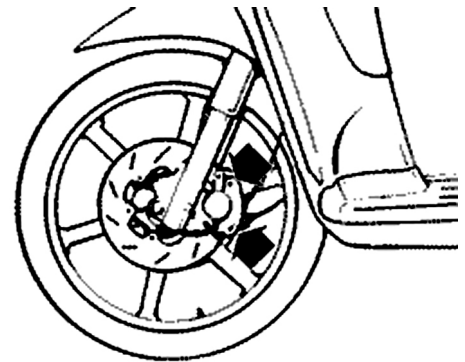
**Locking torques (N*m)**

Fixing screw 20 ÷ 25 Nm Brake tube union 20 ÷ 22 Nm

Overhaul

- Remove the calliper assembly bolts and take out the internal parts from both bodies. If necessary, use short blasts of compressed air through the brake fluid passage to facilitate expulsion of the pistons.
- Make sure the cylinders of the calliper inner and outer bodies are not scratched or eroded. If they are, renew the entire calliper.

CAUTION

ALL INTERNAL COMPONENTS MUST BE RENEWED AT EACH CALLIPER OVERHAUL.

Refitting

Insert the following parts into the calliper half bodies:

- sealing rings (1-2);
- pistons (3);
- fit O-ring seal (4) in one of the pump bodies.
- Couple the inner and outer bodies by means of the coupling bolts. Fit the pads and bleed air from the system (see previous paragraphs).
- Position the caliper on the disc and fasten it to the support, tightening the bolts.
- Secure the tube connection to the caliper with the required torque.
- Before reassembly, the parts must be perfectly clean and **bear no traces of oil, diesel fuel, grease**, etc.. They must therefore be washed thoroughly in denatured alcohol before proceeding.

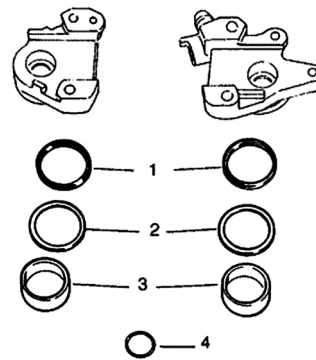

Immerse the seals in brake fluid; the use of protective agent PRF1 is tolerated.

CAUTION

RUBBER PARTS MUST NOT BE LEFT IN ALCOHOL FOR MORE THAN 20 SECONDS. AFTER WASHING, DRY THE PARTS WITH COMPRESSED AIR AND A CLEAN CLOTH

Locking torques (N*m)

Screw fixing the caliper to the support 20 ÷ 25
Calliper to tube connection 8 ÷ 12 Nm

1 DUST SEALS

2 OIL SEALS

3 PISTONS

4 O-RING

Front brake disc

Removal

- Remove the wheel by removing the spindle fixings.

- Unscrew the 6 disc fixing screws.

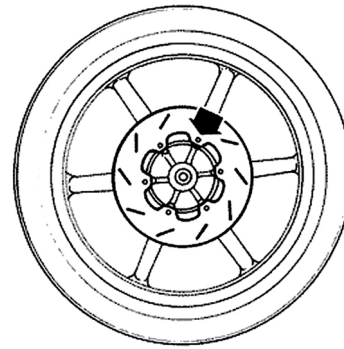

Refitting

- When reassembling, ensure the disc is positioned correctly in relation to the direction of rotation.

Locking torques (N*m)

Disc screws: $8 \div 12$

Disc Inspection

- Remove the wheel and check disc flatness.
Maximum permissible out of true is 0.1 mm. If the value measured is greater, fit a new disc and repeat the check.
- If the problem persists check and replace the wheel if necessary.

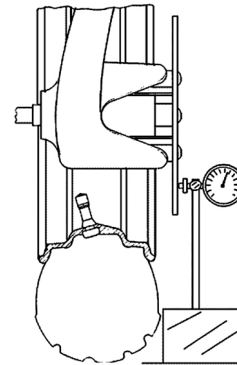

Specific tooling

020335Y Magnetic stand and comparator

Front brake pads

Removal

- To facilitate this operation remove the two caliper fixings. With the calliper detached from its support but still connected to the brake fluid line, remove the plastic cover by prising it with a screwdriver.
 - Remove the outside circlip from the brake pad
-

pin, the leaf spring and the pads.

- Renew the pads when friction facing thickness is less than 1.5 mm.

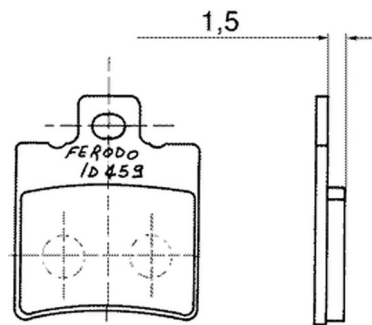

Refitting

- To reassemble perform the above steps in reverse order. Position the leaf spring with the arrow facing up.

Fill

Front

-With the bleed valve closed, fill the system to the maximum level with brake fluid.

- Loosen the bleed valve.

- Apply the Mityvac vacuum pump tube to the bleed valve.

To bleed the circuit you must supply the reservoir constantly with brake fluid while pumping the Mityvac pump until there are no more air bubbles in the circuit.

The operation is concluded when the bleed valve delivers brake fluid and no air.

- Close the bleed valve.

When you have finished the above procedure, tighten the bleed screw to the prescribed torque.

N.B.

IF YOU FIND YOU CANNOT ELIMINATE THE AIR, EXAMINE ALL THE UNIONS IN THE CIRCUIT.

IF YOU DON'T FIND ANY LEAKS, SEEK THE FAULT IN THE VARIOUS SEALS ON THE

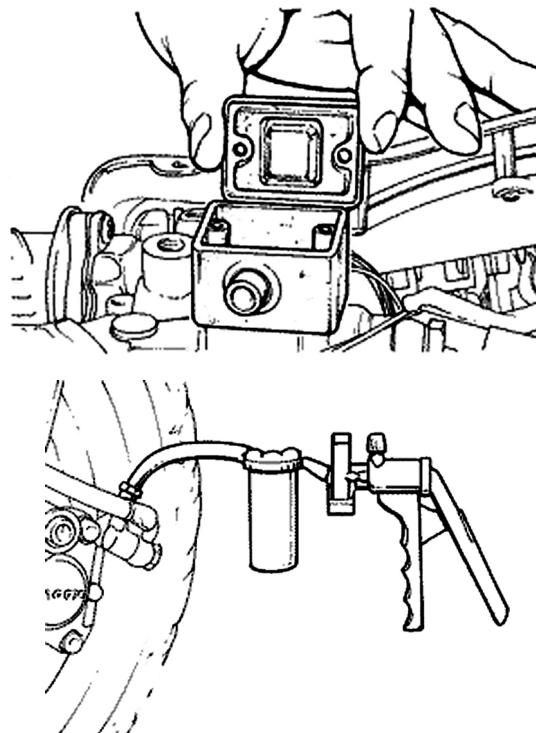

MASTER CYLINDER AND BRAKE CALLIPER PISTONS.**CAUTION**

DURING THIS PROCEDURE THE VEHICLE MUST BE ON THE STAND ON A LEVEL AND HORIZONTAL FLOOR.

N.B.

DURING THE BLEED PROCEDURE, CHECK THE FLUID LEVEL IN THE MASTER CYLINDER RESERVOIR FREQUENTLY TO PREVENT THE RISK OF AIR ENTERING THE CIRCUIT THROUGH THE MASTER CYLINDER.

WARNING

BRAKE FLUID IS HYGROSCOPIC. I.E. IT TENDS TO ABSORB MOISTURE FROM THE SURROUNDING AIR.
IF THE LEVEL OF MOISTURE IN THE FLUID EXCEEDS A GIVEN VALUE, BRAKING EFFICIENCY WILL BE REDUCED.
THEREFORE, ALWAYS USE FLUID FROM SEALED CONTAINERS.
IN NORMAL RIDING AND CLIMATIC CONDITIONS THE BRAKE FLUID SHOULD BE CHANGED EVERY 2 YEARS.
IF THE BRAKES ARE USED INTENSELY AND/OR IN HARSH CONDITIONS, CHANGE THE FLUID MORE FREQUENTLY.

CAUTION

DURING THE ABOVE PROCEDURES BRAKE FLUID MAY LEAK FROM BETWEEN THE BLEED SCREW AND ITS SEAT ON THE CALLIPER.
DRY THE CALLIPER CAREFULLY AND DEGREASE THE DISC TO REMOVE ALL TRACES OF BRAKE FLUID.

Specific tooling

020329Y Pump MITYVAC

Recommended products

TUTELA TOP 4 Brake fluid

Synthetic fluid SAE J1703, NHTSA 116 DOT 4,
ISO 4925

Locking torques (N*m)

Oil drainage screw 8 ÷ 12

Front brake pump

- After removing the front and rear handlebar cover remove the two U clamp fixing screws (see figure).
- Disconnect the brake tube and allow the brake fluid to flow into a receptacle.

- To reassemble perform the steps in reverse order.
- Tighten the brake tube connection to the prescribed torque and bleed the system.

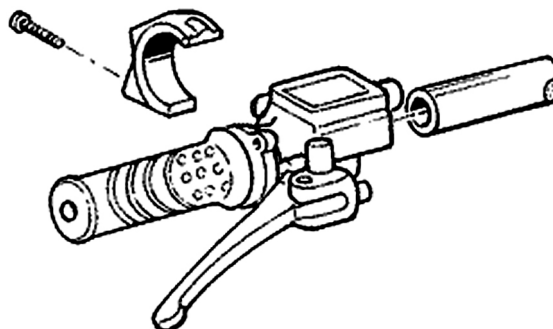
Locking torques (N*m)
Brake tube connection 20 ÷ 25 Nm

Removal

- Drain the brake fluid from the circuit through the bleeding screw on the calliper. Actuate the brake lever until the fluid stops flowing out.
- Remove the master cylinder from the handlebar, take off the brake lever and proceed to remove the brake cylinder.

- 1 - Reservoir cover screw
- 2 - Reservoir cover
- 3 - Membrane
- 4 - Bellows
- 5 - Sealing ring
- 6 - Piston
- 7 - Gasket
- 8 - Spring

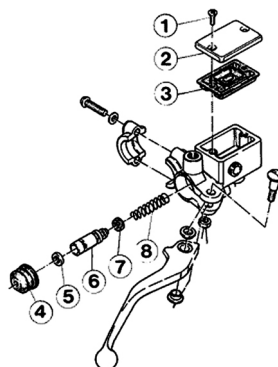
CAUTION

THE PRESENCE OF BRAKE FLUID ON THE DISC OR PADS REDUCES BRAKING ACTION. IN THIS CASE, RENEW THE PADS AND CLEAN THE DISC WITH A HIGH QUALITY SOLVENT.

CAUTION: BRAKE FLUID CAN DAMAGE PAINTWORK.
DO NOT LEAVE RUBBER PARTS IN ALCOHOL FOR MORE THAN 20 SECONDS.
AFTER WASHING, DRY THE PARTS WITH A BLAST OF COMPRESSED AIR AND A CLEAN CLOTH.
SEALING RINGS MUST BE IMMERSSED IN BRAKE FLUID.

Refitting

Before reassembly, the parts must be perfectly clean and bear no traces of oil, diesel fuel, grease, etc.. They must therefore be washed thoroughly in denatured alcohol before proceeding.

- Perform the disassembly steps in reverse order, taking care to installed rubber parts correctly to ensure an oiltight seal.

- 1 - Reservoir cover screw
- 2 - Reservoir cover
- 3 - Membrane
- 4 - Bellows
- 5 - Sealing ring
- 6 - Piston
- 7 - Gasket
- 8 - Spring

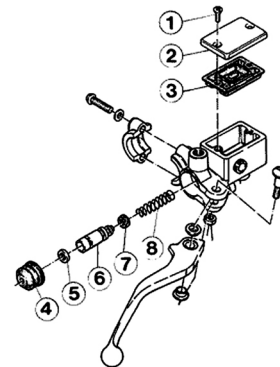

INDEX OF TOPICS

CHASSIS

CARROZ

BODYWORK

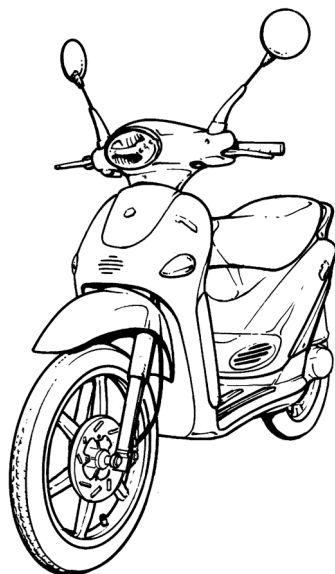

Taking apart approached cover motor

Remove the 2 implantations.



Seat

- Unscrew the 2 screws securing it and remove it

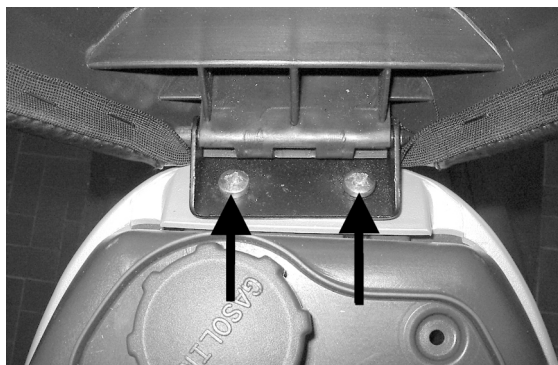

Side fairings

- Remove the countershield
- Unscrew the 4 screws securing it and remove the bumper band

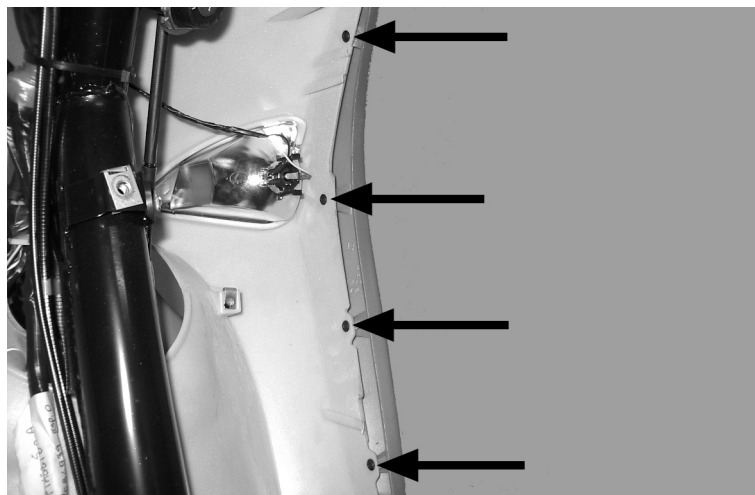

See also

[Knee-guard](#)

Rear rack

- Use a screwdriver from the back part and remove the plastic cap covering the central screw.
- Remove the central screw and the two side ones.

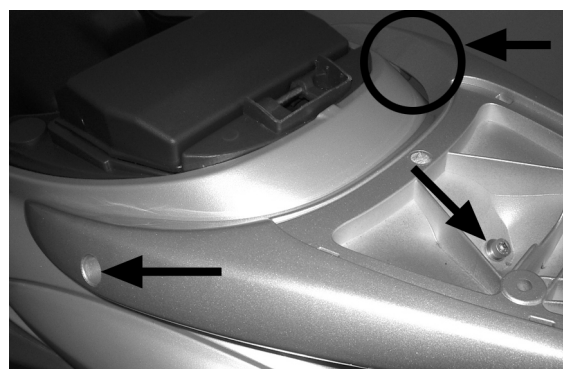

Driving mirrors

- With the register screw completely tightened, screw the mirror stem all the way down on the handlebars.

- Loosen the mirror and put it in the desired position.
- Loosen the register screw until the stem is tightened.

Locking torques (N*m)

Mirror register screw 24÷26

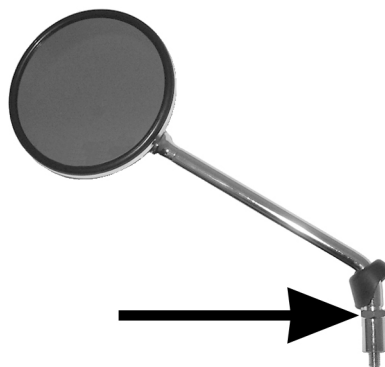

Rear handlebar cover

- Remove the front handlebar fairing
- Unscrew the speedometer transmission connection and remove it
- Disconnect the instrument unit and electrical control connections

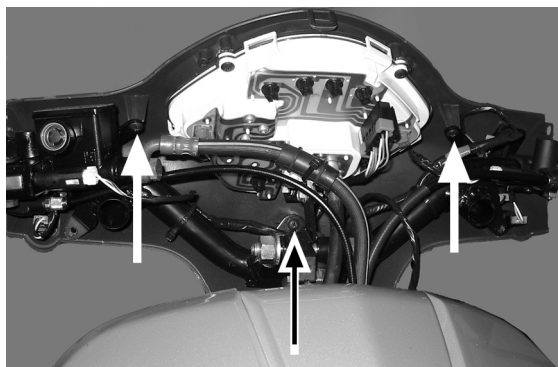

- Cut the band holding the front brake hoses to the instrument unit
- Remove the screw securing the instrument unit to the handlebar

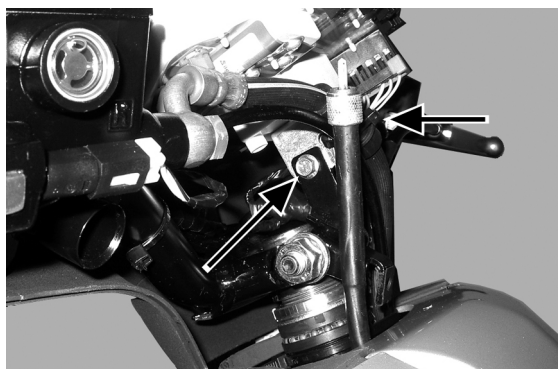

See also

[Front handlebar cover](#)

Instrument panel

- Remove the rear handlebar fairing
- Unscrew the 4 screws securing it and remove the instrument unit

N.B.

THE BULBS HAVE BAYONET COUPLING ON THE

LAMP-HOLDER; THE LAMP-HOLDER CAN BE REMOVED BY ROTATING IT 30° ANTI-CLOCKWISE. THE CLOCK RUNS ON A BATTERY

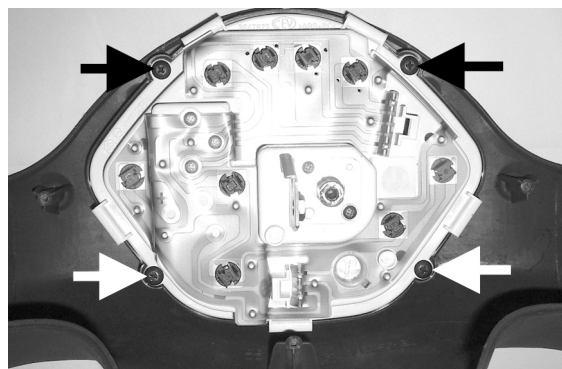

See also

[Rear handlebar cover](#)

Front handlebar cover

- Remove the 2 screws in the handlebar fairing and the screw under the headlight.
- Pull up to release the handlebar fairing and disconnect the headlight connections

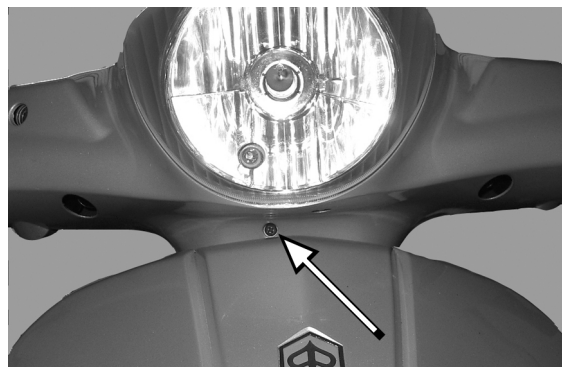

Headlight assy.

- Remove the front handlebar fairing
- Unscrew the 4 screws securing it and remove the headlight

N.B.

TO REPLACE THE HIGH BEAM/DIPPED BEAM BULB THE RUBBER COVER MUST BE REMOVED

AND THE SUPPORT PLATE ROTATED 30° ANTI-CLOCKWISE. TO REPLACE THE POSITION LIGHT BULB, JUST REMOVE IT FROM THE RUBBER LAMP-HOLDER.

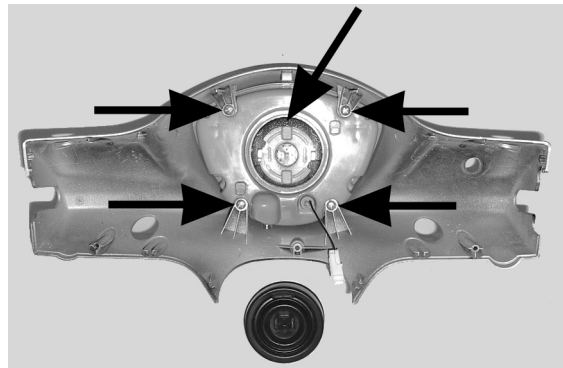

See also

[Front handlebar cover](#)

Frame central cover

- Remove the rear rack
- Remove the saddle
- Remove the sparkplug cap, then unscrew the 2 screws connecting the saddle compartment band with the footrest.

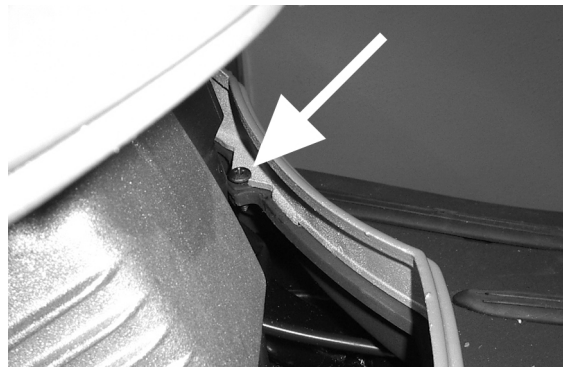

- Unscrew the two side screws on the bumper bands
- Remove the cover by lifting the rear part and disconnecting the headlight and turn signal connections

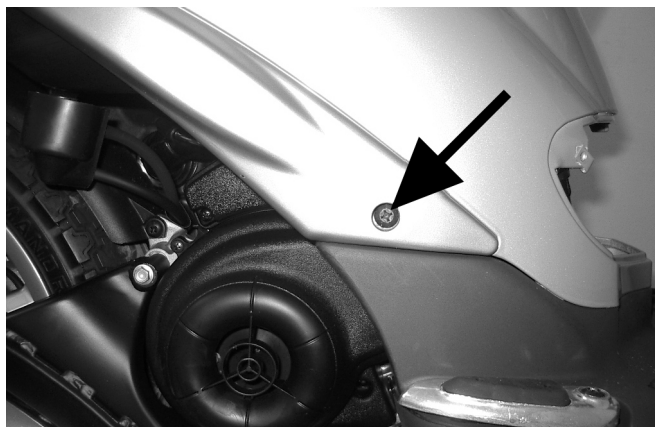

See also

[Rear rack](#)

[Seat](#)

Legshield

- Remove the countershield
- Remove the footrest
- Remove the front steering tube
- Remove the front shield using a blade and working carefully on the right side of it
- Unscrew the screw below and lift off the cover

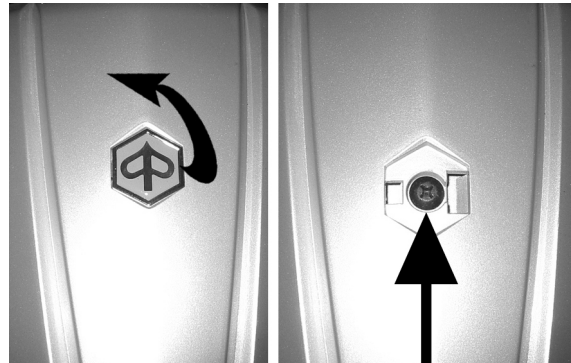

- Unscrew the front screw securing the shield

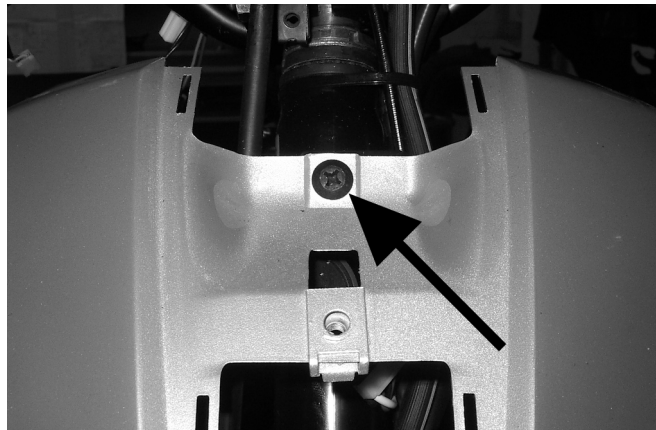

- Unscrew the lower 2 screws, then remove the shield after having disconnected the turn signal connections

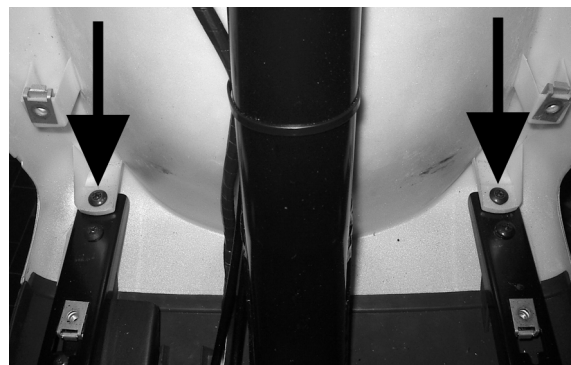

See also

[Knee-guard](#)

[Footrest](#)

[Removal](#)

Knee-guard

- Remove the 4 external screws of the coun-

tershield and the 3 located inside the front glove box

- Use the bag clip to pull the countershield back until releasing it with the front shield

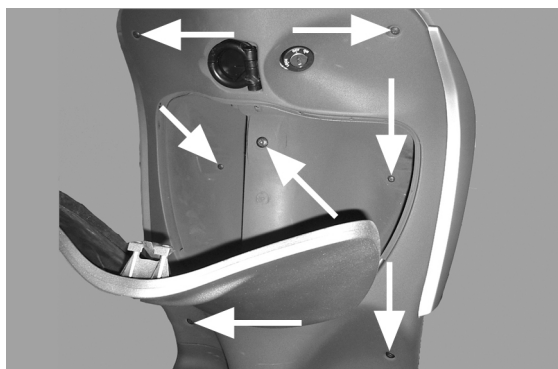

Removing the ignition key-switch when on

- Remove the countershield
- Press the lock body until the clip appears from the groove
- Keep the lock body still and use pliers to remove the clip
- Remove the lock block



See also

[Knee-guard](#)

Removing the ignition key-switch when on

- Disassemble the shield.
- Remove the keyswitch.
- Drill into the block as shown in the figure.
- Insert the cylinder complete with key and with the locking tab facing downwards about half way into the lock body ensuring that during insertion the key is turned to the «ON» position (this is the only position that allows the cylinder to be inserted into the lock body); turn the key to the left towards the «OFF» position and simultaneously press the cylinder fully home.

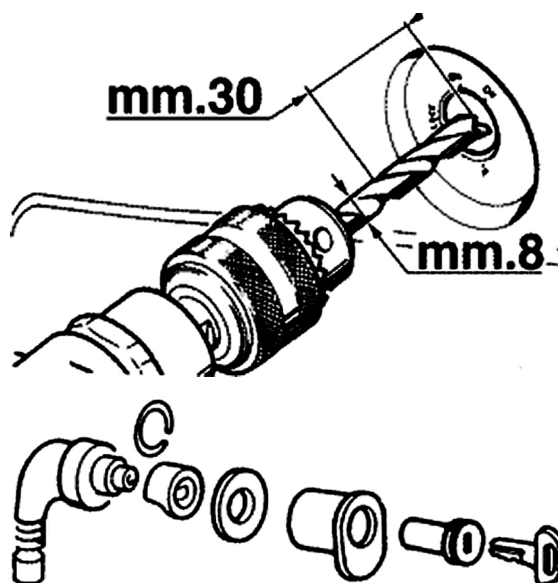

Taillight assy.

- To remove the taillight and position light or the 2 turn signals, just unscrew the screws located on the related light covers and disconnect the electrical connections.

N.B.

REMOVAL OF THE REAR LIGHT BULBS IS ONLY POSSIBLE BY REMOVING THE LIGHT COVERS ROTATING THEM 30° ANTI-CLOCKWISE.

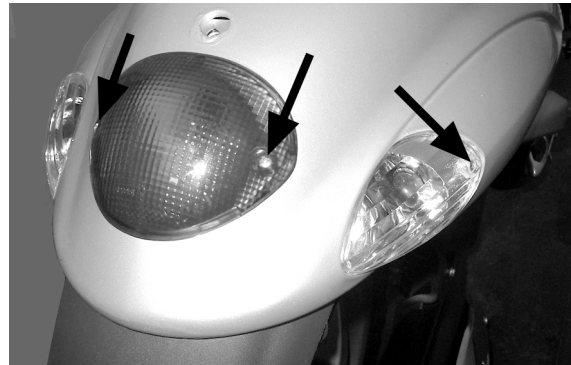

Footrest

- Remove the countershield
- Remove the frame central cover
- Unscrew the screws that secure the passenger footrest and remove it
- Unscrew the footrest stop screw and remove the tab

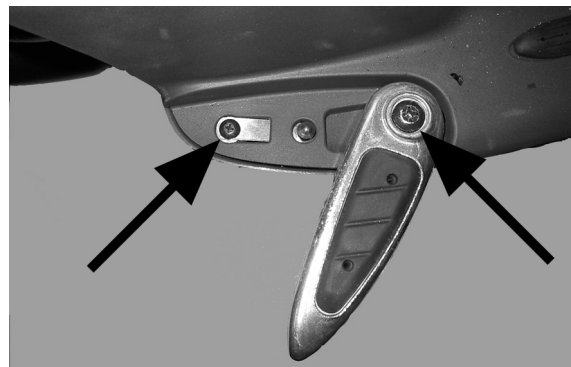

- Remove the 2 external rubber caps of the screws securing the footrest and unscrew them
- Pull the footrest up being careful of the lower hooks

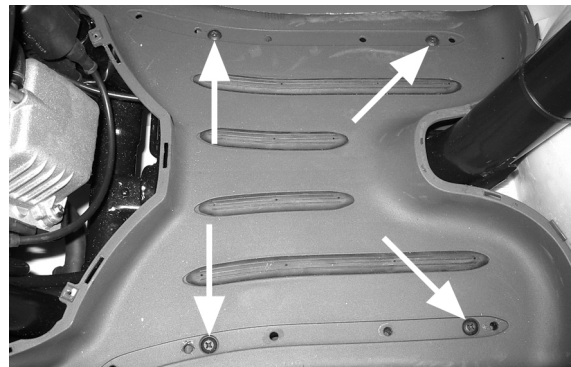

See also

[Knee-guard](#)

[Frame central cover](#)

License plate holder

- Remove the saddle compartment cover
- Unscrew the 2 screws securing it to the frame,

then remove the license plate housing

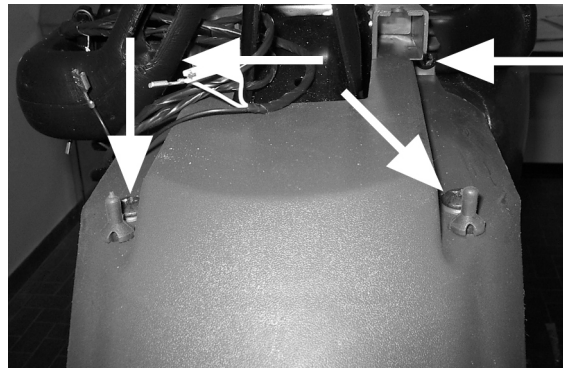

See also

[Frame central cover](#)

Air filter

- Unscrew the 7 screws located on the cover and remove it to access the filtering sponge
- To disassemble the entire filter box, unscrew the 2 lower screws and disconnect the sleeves connecting the carburetor with the external air intake.

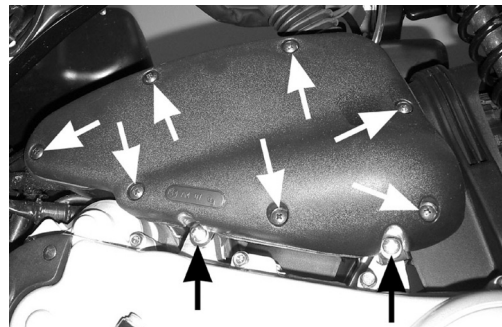

Rear mudguard

- Remove the 3 screws securing it on the left side (including the 2 screws securing the air filter box)
- Remove the screw on the side of the cooling casing
- Remove the mudguard by taking it off the muffler side.

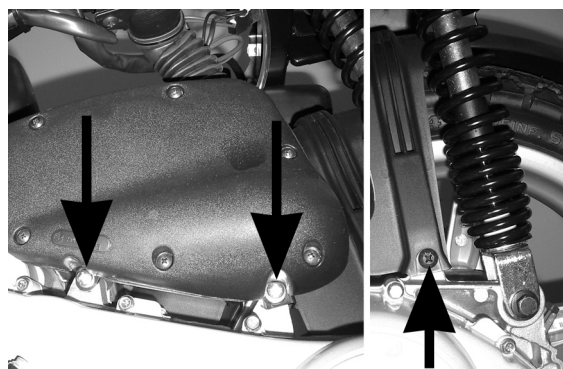

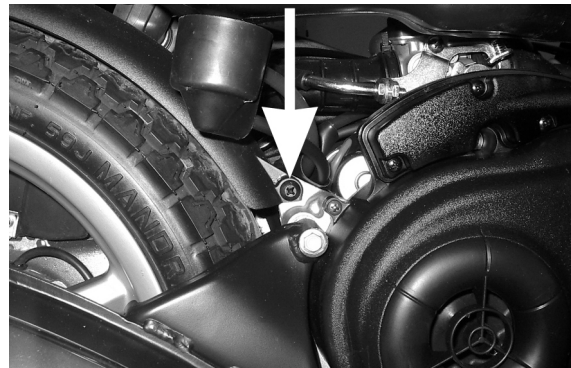

Helmet bay

- Remove the central saddle compartment cover
- Remove the battery and fuse holder
- Remove the fuel tank cap and the starter motor contactor
- Unscrew the rear screw and then lift the helmet compartment

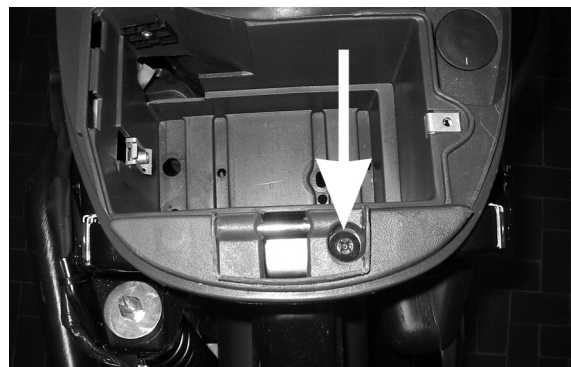

See also

[Frame central cover](#)

spoiler

- Remove the footrest
- Unscrew the two front screws securing it and then remove the spoiler from the bottom

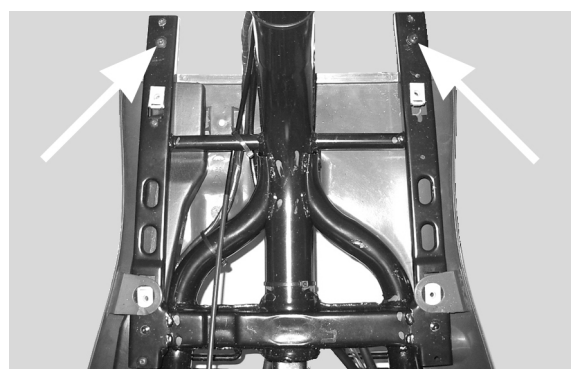

See also

[Footrest](#)

Fuel tank

- Remove the central saddle compartment cover
- Unscrew the front and rear screws on the right side of the frame
- Disconnect the vent tube and disassemble the float

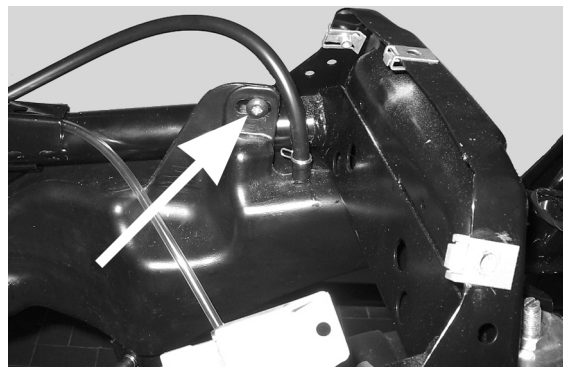
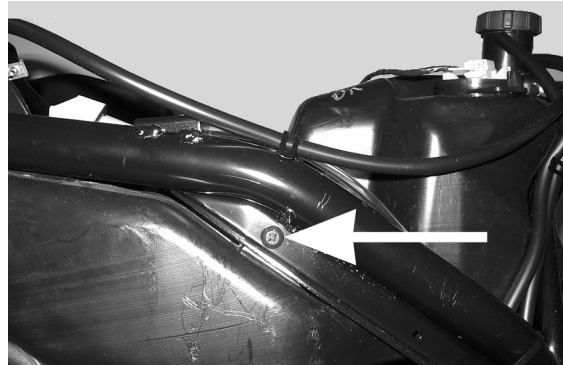

See also

[Frame central cover](#)

Front mudguard

- Leaving the front wheel assembled, disassemble the steering tube from the vehicle
- Unscrew the 3 screws securing it and remove them
- Remove the speedometer transmission and brake hose, then remove the mudguard

N.B.

WHEN REASSEMBLING BE CAREFUL TO POSITION THE 2 METAL GROMMETS TO AVOID ANY RUBBING AGAINST THE WHEEL.

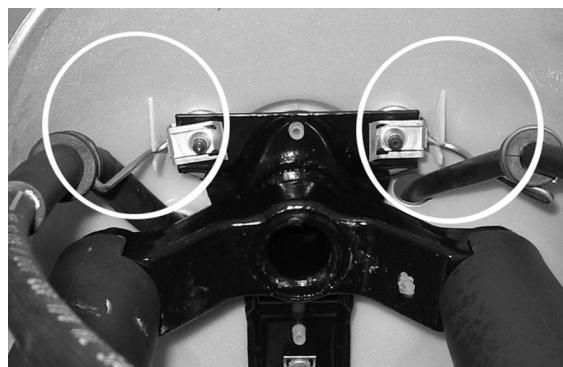
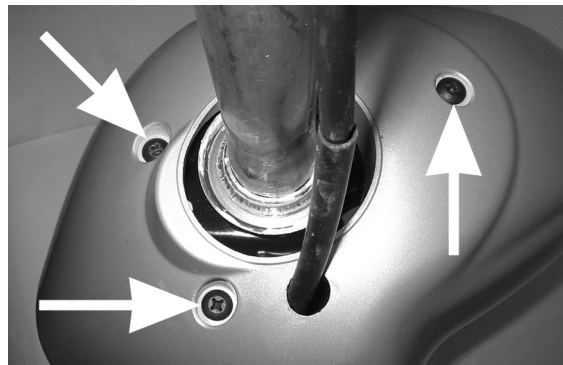

See also

[Removal](#)

Top-case

Front

Disassembling the inner shield fairing (glove box assy.)

- Remove the two screws from inside the glove box.
 - Remove the two screws at the lower part of the inner shield fairing
 - Remove the two screws located behind the front grille.
-



INDEX OF TOPICS

PRE-DELIVERY

PRECON

Aesthetic inspection

Predelivery checks:

- Paintwork
- Mating of plastics
- Scratches
- Dirt

Tightening torques inspection

Locks Inspection

- Safety locks
- Fixing screws

Safety locks:

Rear shock absorber top tightening	20 ÷ 25 N·m
Rear shock absorber bottom tightening	33 ÷ 41 N·m
Front wheel axle nut	45 ÷ 50 N·m
Wheel hub nut	75 ÷ 85 N·m
Screws fixing the rear wheel rim to the hub	20 ÷ 25 N·m
Oscillating arm pin - Chassis	64 ÷ 72 N·m
Oscillating arm pin - Engine	33 ÷ 41 N·m
Chassis arm-engine arm pin	33 ÷ 41 N·m
Handlebar locking nut	43÷47 N·m
Steering wheel lower ring nut	10 ± 13 N·m
Steering wheel upper ring nut	30 ± 33 N·m

Electrical system

Electric System:

- Master switch
- Headlights: upper beams, dipped beams, side/taillights , stop lights and relevant light indicators
- Headlight setting according to the regulations in force
- Rear light, parking light, stop light - Front and rear stop switches

- Direction indicators and relevant lights - Instrument panel lights
- Instruments: fuel and temperature indicator
- Instrument unit indicator lights
- Horn
- Starter

CAUTION

TO ENSURE MAXIMUM PERFORMANCE, THE BATTERY MUST BE CHARGED BEFORE USE. INADEQUATE CHARGING OF THE BATTERY BEFORE IT IS FIRST USED WITH A LOW LEVEL OF THE ELECTROLYTE SHORTENS THE LIFE OF THE BATTERY.

WARNING

BEFORE RECHARGING THE BATTERY, REMOVE THE PLUGS OF EACH ELEMENT. KEEP SPARKS AND FREE FLAMES AWAY FROM THE BATTERY WHILE RECHARGING. REMOVE THE BATTERY FROM THE VEHICLE DISCONNECTING THE NEGATIVE TERMINAL FIRST.

CAUTION

WHEN INSTALLING THE BATTERY, FIRST FIX THE POSITIVE CABLE AND THEN THE NEGATIVE CABLE.

WARNING

THE BATTERY ELECTROLYTE IS POISONOUS AND CAUSES SEVERE BURNS AS IT CONTAINS SULPHURIC ACID. AVOID CONTACT WITH THE EYES, THE SKIN AND CLOTHING. IN CASE OF CONTACT WITH THE EYES OR THE SKIN, RINSE GENEROUSLY WITH WATER FOR ABOUT 15 MINUTES AND IMMEDIATELY SEEK MEDICAL ATTENTION. IN CASE OF INGESTION, IMMEDIATELY DRINK LARGE QUANTITIES OF WATER OR VEGETABLE OIL. IMMEDIATELY SEEK MEDICAL ATTENTION. BATTERIES PRODUCE EXPLOSIVE GASES. KEEP THEM AWAY FROM OPEN FLAMES, SPARKS AND CIGARETTES. IF THE BATTERY IS CHARGED IN A CLOSED PLACE, TAKE CARE TO ENSURE ADEQUATE VENTILATION. ALWAYS PROTECT THE EYES WHEN WORKING CLOSE TO BATTERIES. KEEP OUT OF REACH OF CHILDREN

CAUTION

NEVER USE FUSES HAVING A HIGHER RATING THAN RECOMMENDED. USING A FUSE OF UNSUITABLE RATING MAY SERIOUSLY DAMAGE THE VEHICLE OR EVEN CAUSE A FIRE.

Levels check

Level check

- Hydraulic braking system fluid level
 - Rear hub oil level
 - Engine coolant level
-

Road test

Road test:

- Cold starting
 - Operation of instruments
 - Operation of throttle control
 - Stability during acceleration and braking
 - Operation of front and rear brakes
 - Operation of front and rear suspensions
 - Abnormal noise from vehicle
-

Static test

Static inspection after test on the road:

- Hot start
- Starter operation
- Idle speed hold (by turning the handlebar)
- Even steering wheel rotation
- Leaks, if any

CAUTION

CHECK THE INFLATING PRESSURES WHEN THE TYRES ARE AT AMBIENT TEMPERATURE.

CAUTION

NOT EXCEED THE RECOMMENDED INFLATING PRESSURES AS THE TYRES MAY BURST.

Functional inspection

Functional Check:

Braking system (hydraulic)

- Lever stroke

Braking system (mechanical)

- Lever stroke

Clutch

- Proper performance check

Engine

- Gas control stroke check Miscellaneous
 - Document check
 - Check of chassis no. and engine no.
 - Ancillary tools
-

- Plate assembly
 - Check of locks
 - Tyre pressure check
 - Installation of rear-view mirrors and optional fixtures
-

INDEX OF TOPICS

TIME

TEMP

This section describes the amount of time it takes for repair operations.

The description, code and amount of time for each operation are indicated.



Engine

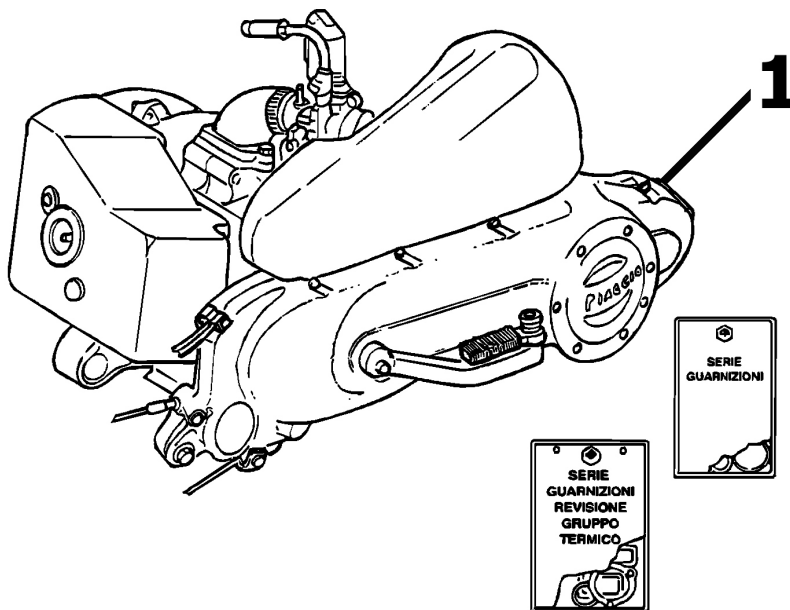

ENGINE

	Code	Action	Duration
1	001001	Engine to frame - Disassembly and reassembly	90'

Crankcase

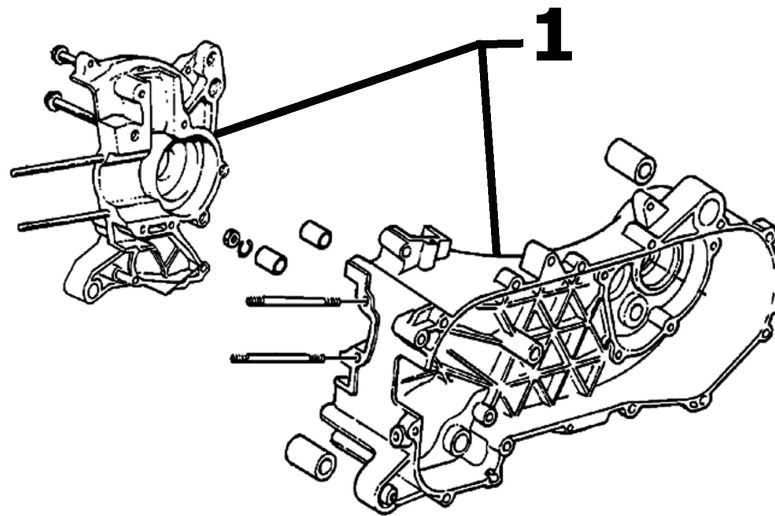

CRANKCASE

	Code	Action	Duration
1	001133	Engine crankcase - Replacement	190'

Crankshaft

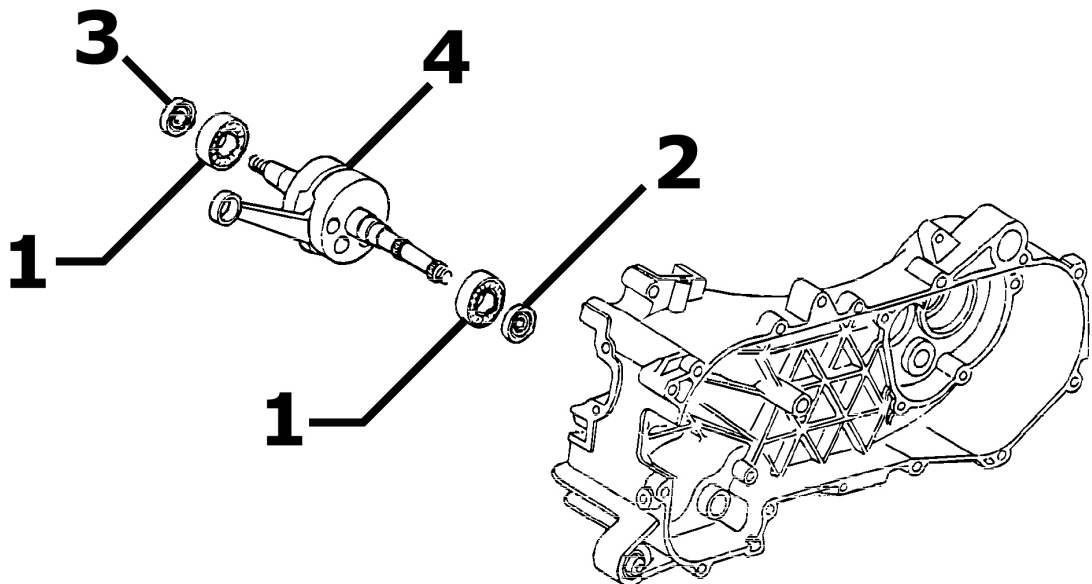

DRIVING SHAFT

	Code	Action	Duration
1	001118	Main bearings - Replacement	170'
2	001100	Oil seal clutch side - Replacement	55'
3	001099	Oil seal flywheel side - Replacement	50'
4	001117	Crankshaft - Replacement	170'

Cylinder assy.

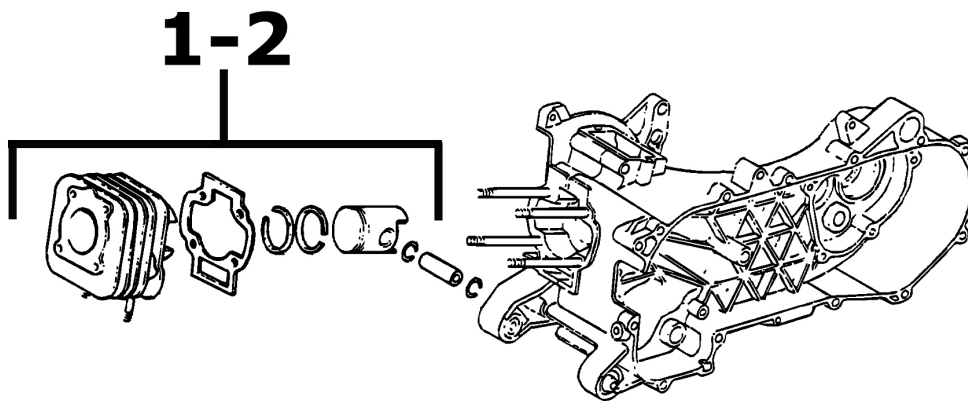

PISTON CYLINDER

	Code	Action	Duration
1	001002	Piston cylinder - Replacement	55'
2	001007	Cylinder, piston - Overhaul/ Cleaning	50'

Cylinder head assy.

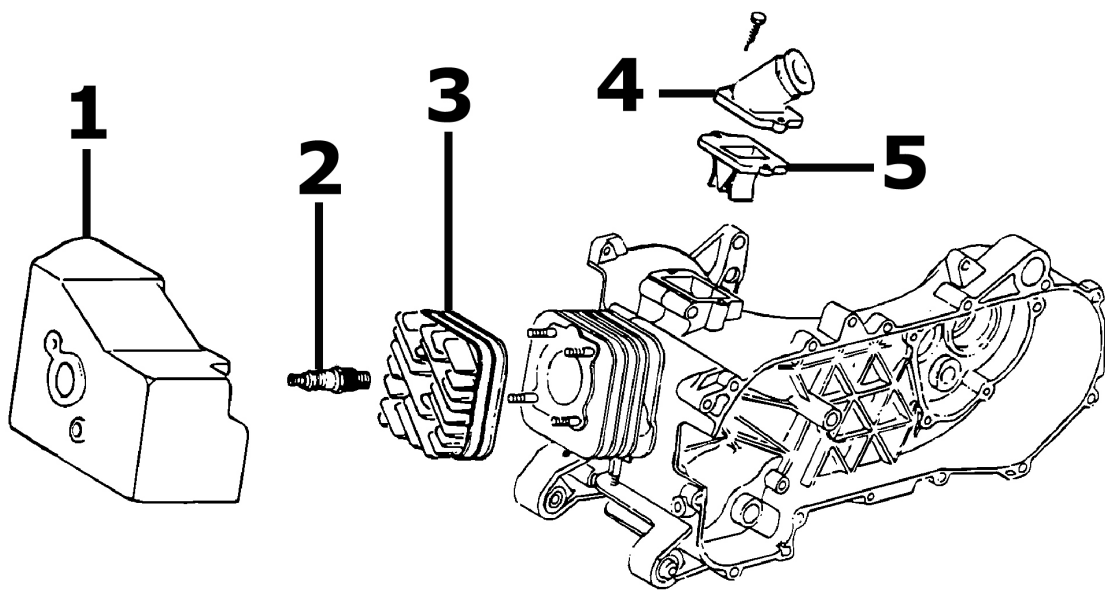

HEAD

	Code	Action	Duration
1	001097	Cooling hood - Replacement	25'
2	001093	Spark plug - Replacement	10'
3	001126	Head - Replacement	50'
4	001013	Intake manifold - Replacement	40'
5	001178	Reed valve assembly - Replacement	45'

Driven pulley

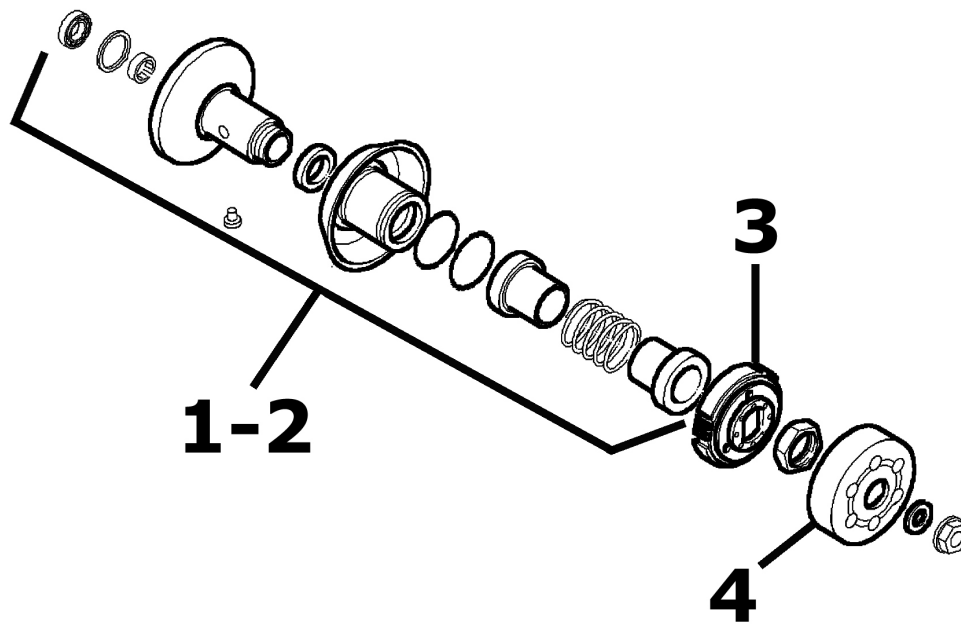

DRIVEN PULLEY - CLUTCH

	Code	Action	Duration
1	001012	Driven pulley - Overhaul	50'
2	001110	Driven pulley - Replacement	35'
3	001022	Clutch - Replacement	40'
4	001155	Clutch bell housing - Replacement	20'

Oil pump

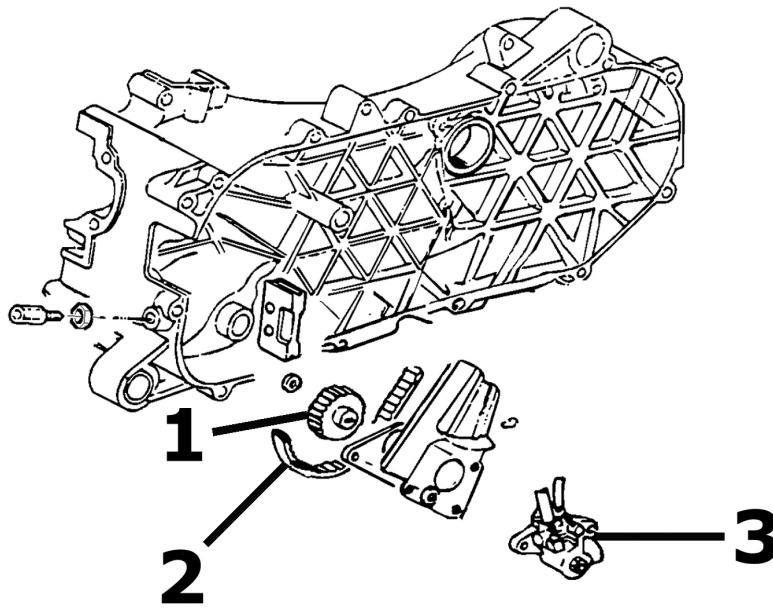

OIL PUMP

	Code	Action	Duration
1	001028	Mixer drive gear - Replacement	55'
2	001019	Mixer belt - Replacement	30'
3	001018	Mixer - Replacement	40'

Driving pulley

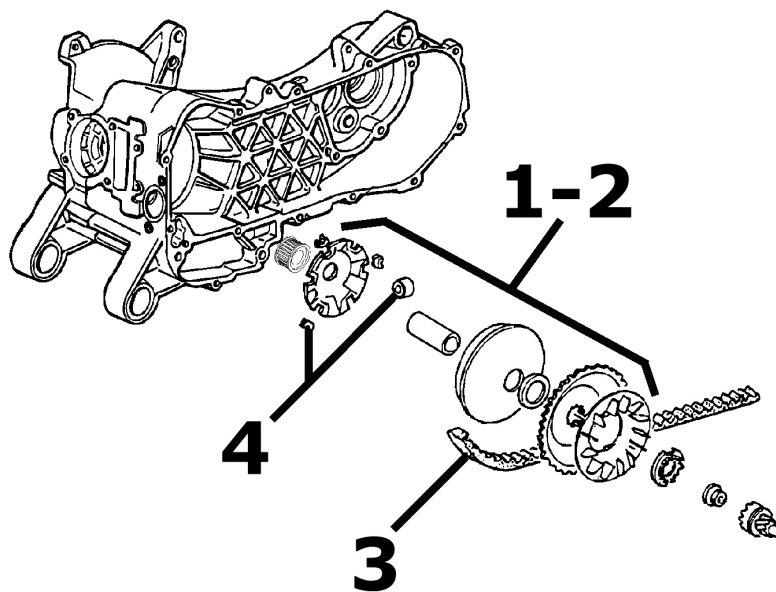

DRIVING PULLEY

	Code	Action	Duration
1	001066	Driving pulley - Disassembly and reassembly	25'
2	001086	Driving half pulley - Replacement	25'
3	001011	Driving belt - Replacement	25'
4	001177	Rollers / Variator track shoes - Replacement	30'

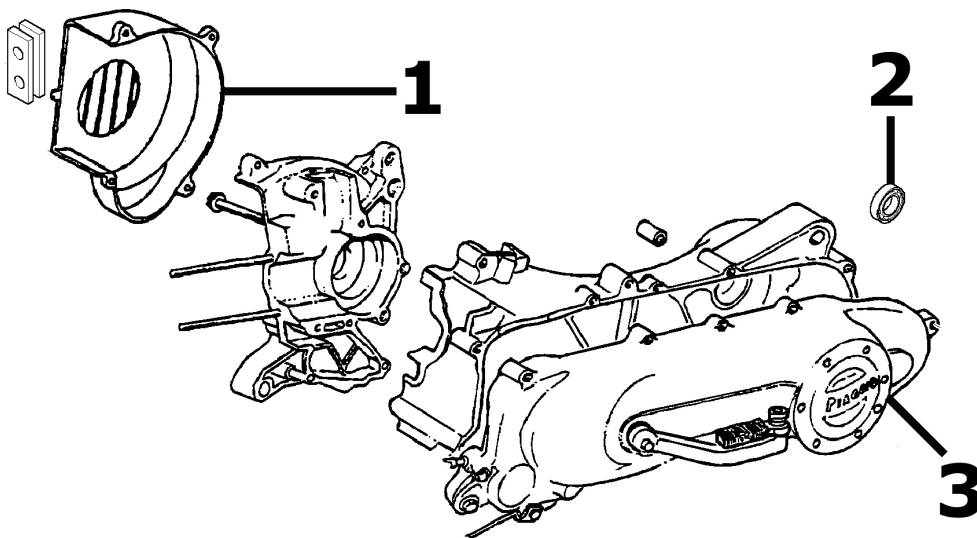
Transmission cover**TRANSMISSION COVER**

	Code	Action	Duration
1	001087	Flywheel cover - Replacement	25'
2	001135	Transmission cover bearing - Replacement	30'
3	001096	Transmission casing cover - Replacement	20'

Flywheel magneto

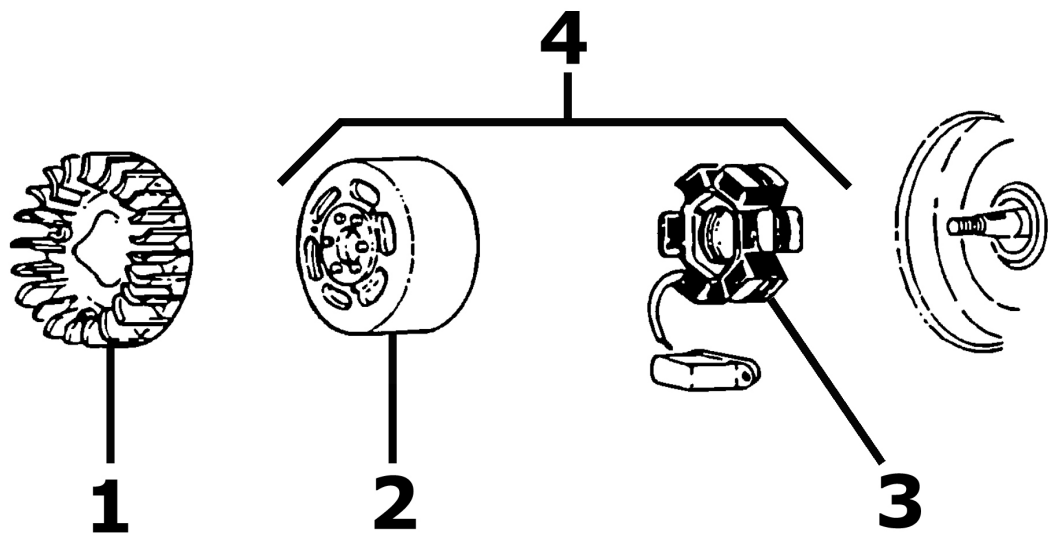

FLYWHEEL - FAN

	Code	Action	Duration
1	001109	Cooling fan - Replacement	30'
2	001173	Rotor - Replacement	50'
3	001067	Stator - Disassembly and re-assembly	50'
4	001058	Flywheel - Replacement	50'

Carburettor

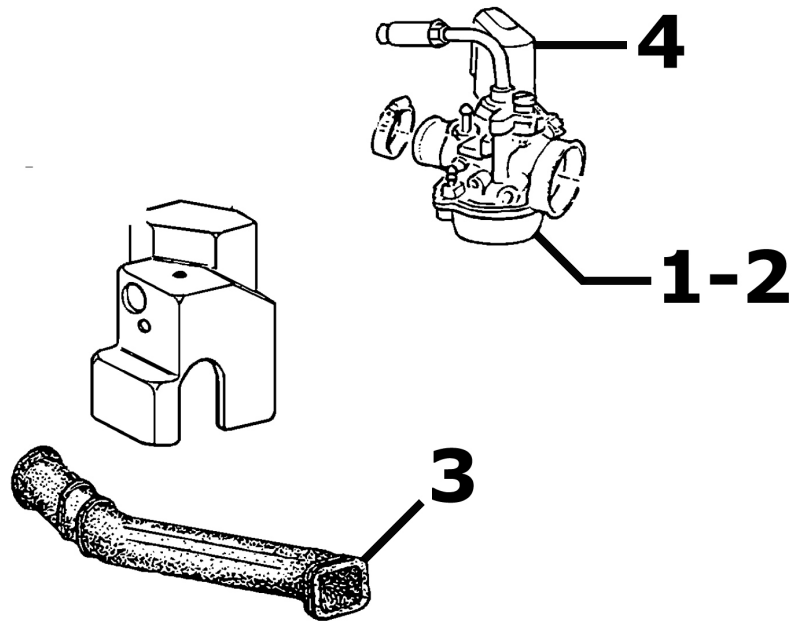

CARBURATOR

	Code	Action	Duration
1	001008	Carburettor - Overhaul	50'
2	001063	Carburettor - Replacement	35'
3	001081	Automatic starter device - Replacement	30'
4	007020	Carburettor heating manifolds - Replacement	20'

Exhaust pipe

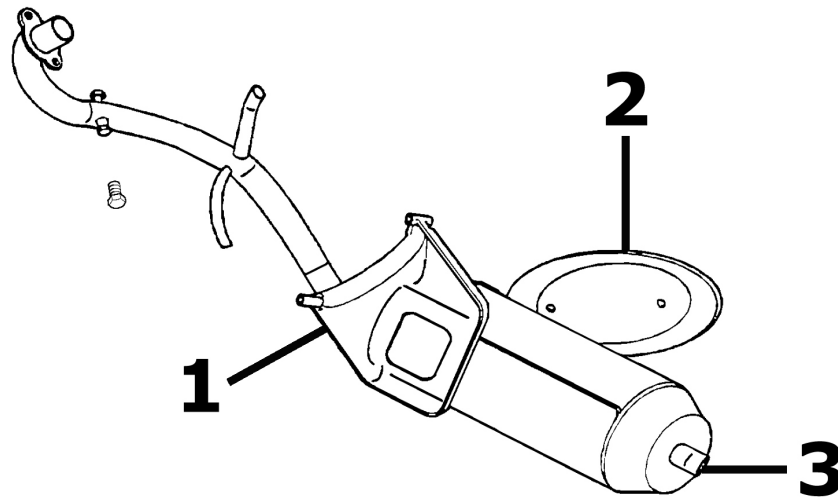

MUFFLER

	Code	Action	Duration
1	001009	Silencer - Replacement	30'
2	001095	Silencer guard - Replacement	10'
3	001136	Exhaust emissions - Adjustment	20'

Air cleaner

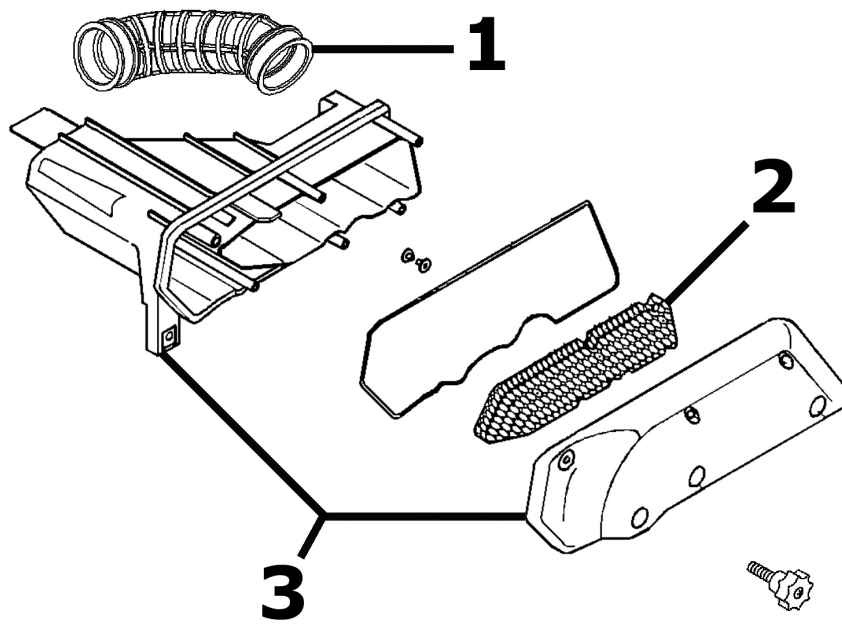

AIR FILTER

	Code	Action	Duration
1	004122	Carburettor filter manifold - Replacement	25'
2	001014	Air Filter - Replacement	30'
3	001015	Air filter box - Replacement	30'

Centre-stand

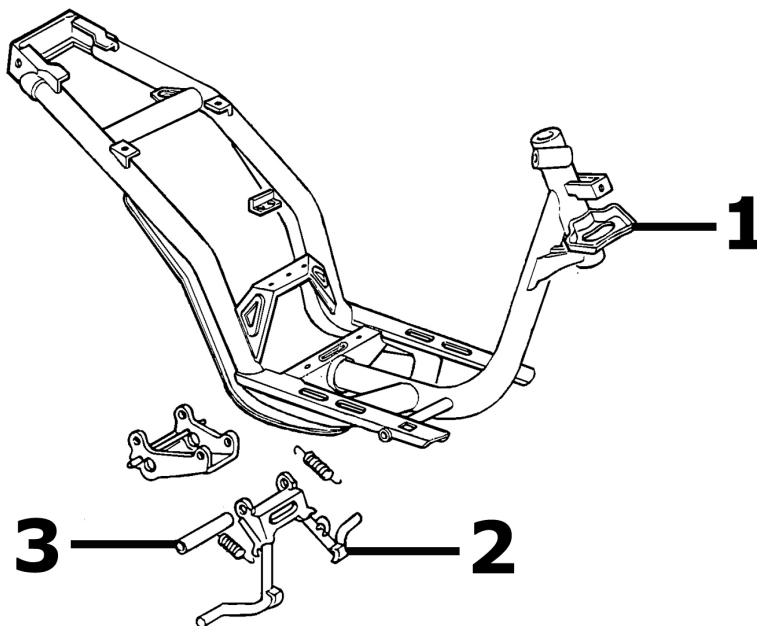

STAND

	Code	Action	Duration
1	004004	Stand - Replacement	20'
2	001053	Stand pin - Replacement	20'

Legshield spoiler

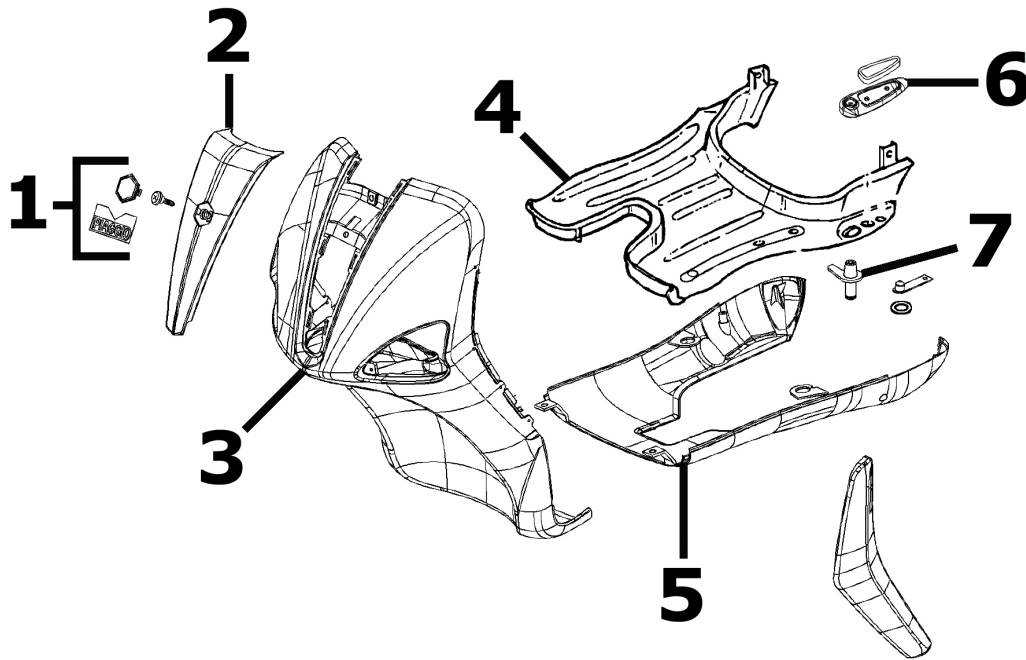

MUFFLER - GLOVE COMPARTMENT

	Code	Action	Duration
1	004159	Stickers - Replacement	10'
2	004149	Front shield - Painting	10'
3	004064	Front shield, front section - Removal and refitting	95'
4	004015	Footrest - Disassembly and reassembly	25'
5	004053	Spoiler - Replacement	50
6	004079	Rear footrest - Replacement	45'
7	004143	Foot-peg mounting bracket - Replacement	45'

Rear cover

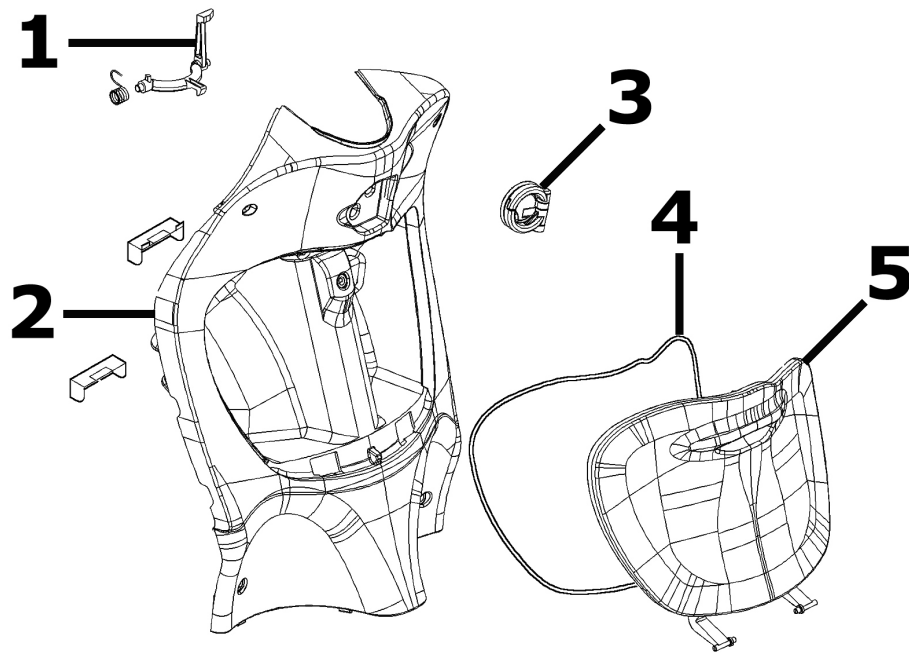

REAR COVER

	Code	Action	Duration
1	004174	Glove-box remote opening linkage - Replacement	20'
2	004065	Knee-guard - Removal and refitting	30'
3	004131	Rear rack mounting bracket - Replacement	20'
4	004082	Glove-box packing - Replacement	10'
5	004081	Glove compartment door - Replacement	35'

Central cover

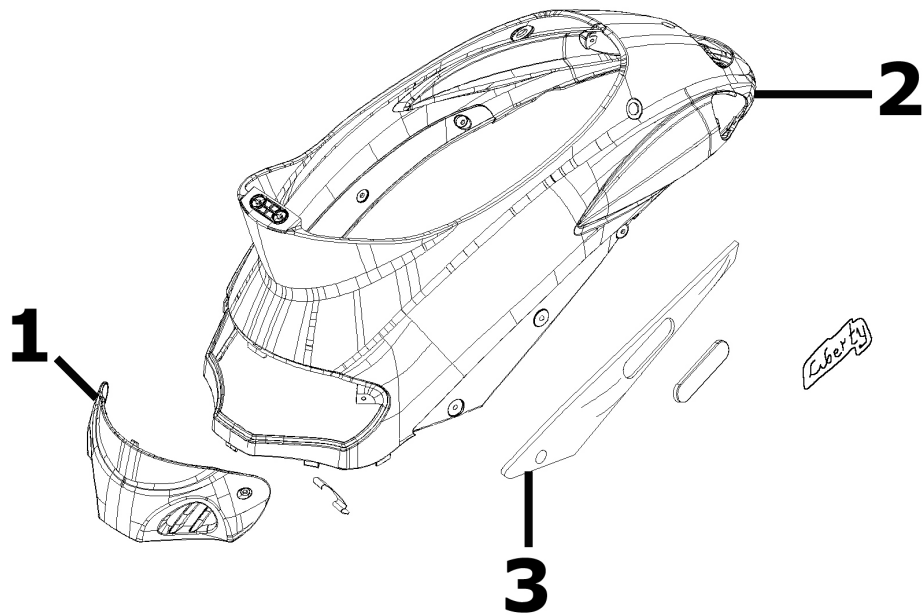

CENTRAL COVER

	Code	Action	Duration
1	004059	Spark plug inspection flap - Replacement	10'
2	004085	Side panel (1) - Replacement	10'
3	004106	Undersaddle band - Replacement	20'

Underseat compartment

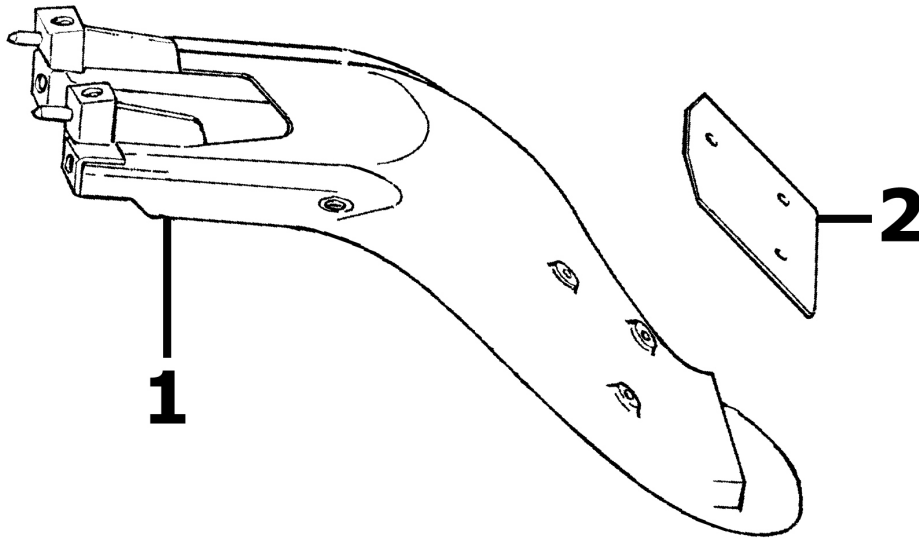

HELMET COMPARTMENT

	Code	Action	Duration
1	004136	License plate holder mounting bracket - Replacement	25'
2	005048	Plate holder - Replacement	10'

Fuel tank

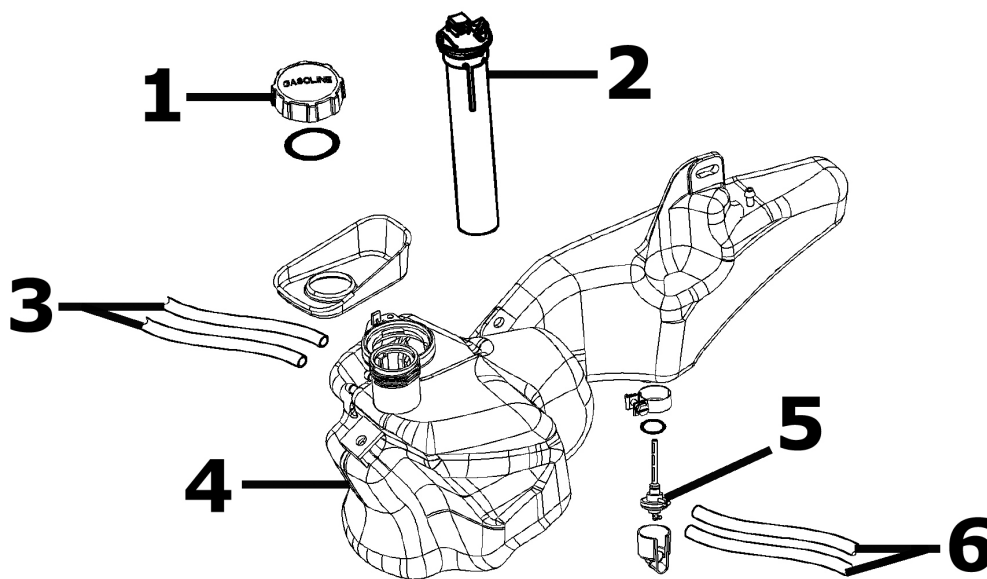

FUEL TANK

	Code	Action	Duration
1	004168	Fuel filler cap - Replacement	10'
2	005010	Fuel tank float - Replacement	45'
3	004109	Fuel tank breather - Replacement	40'
4	004005	Fuel tank - Replacement	40'
5	004007	Mixture cock - Replacement	25'
6	004112	Cock-carburettor pipe - Replacement	10'

serbatoio olio

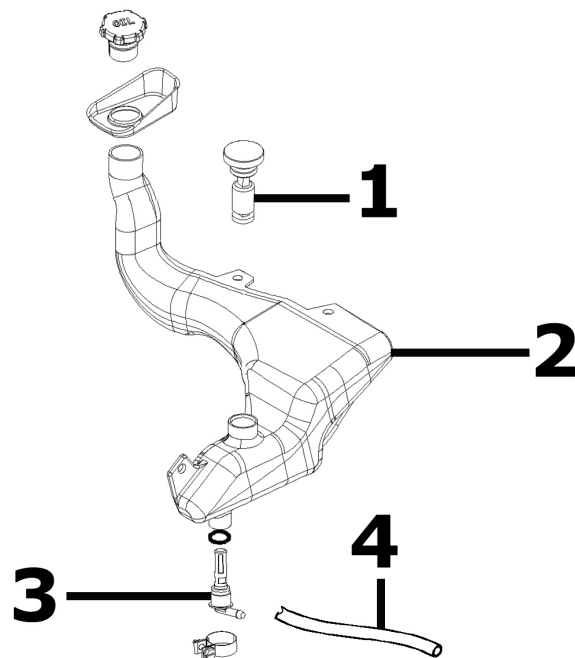

OIL TANK

	Code	Action	Duration
1	005018	Oil tank float - Replacement	45'
2	004017	Oil tank - Replacement	40'
3	004095	Oil tank tap - Replacement	15'
4	004091	Oil tank line - Replacement	15'

Rear shock-absorber

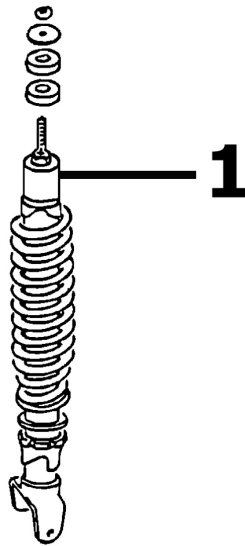

REAR SHOCK ABSORBER

	Code	Action	Duration
1	003007	Rear shock absorber - Disassembly and reassembly	60'

Steering column bearings

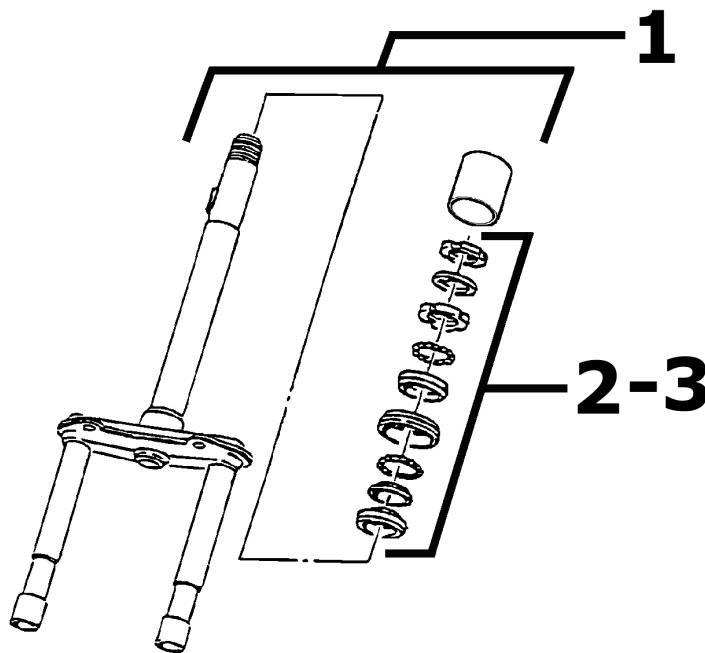

STEERING FIFTH WHEELS

	Code	Action	Duration
1	003051	Fork assembly - Replacement	75'
2	003002	Steering fifth wheels - Replacement	65'
3	003073	Steering play - Adjustment	40'

Handlebar covers

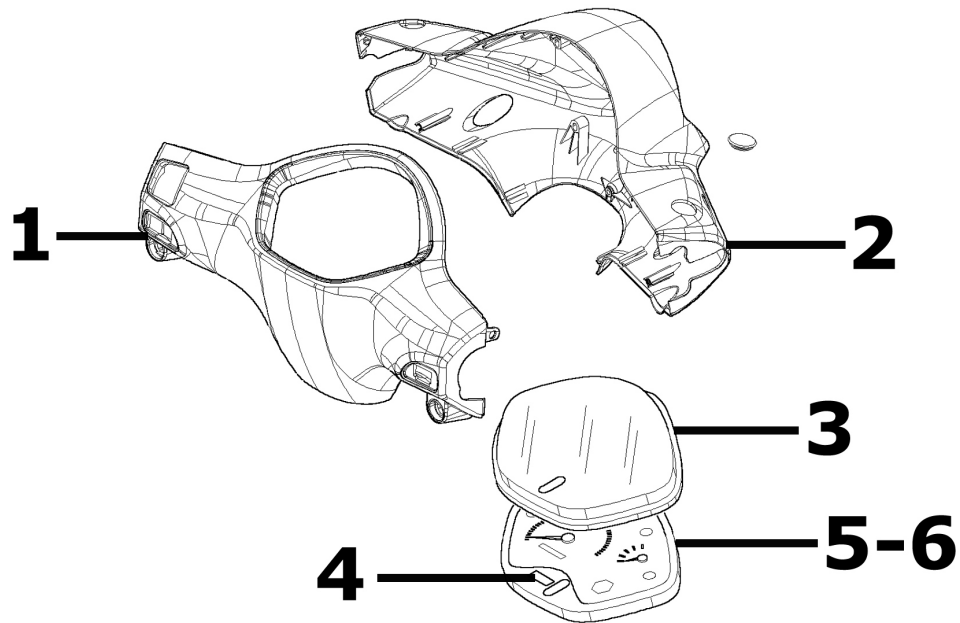

ODOMETER - HANDLEBAR COVERS

	Code	Action	Duration
1	004019	Handlebar rear side - Replacement	10'
2	004018	Handlebar front section - Replacement	15'
3	005078	Odometer plastic cover - Replacement	20'
4	005076	Clock \ Battery - Replacement	25'
5	005014	Odometer - Substitution	20'
6	005038	Dashboard warning lights - Replacement	15'

Handlebar components

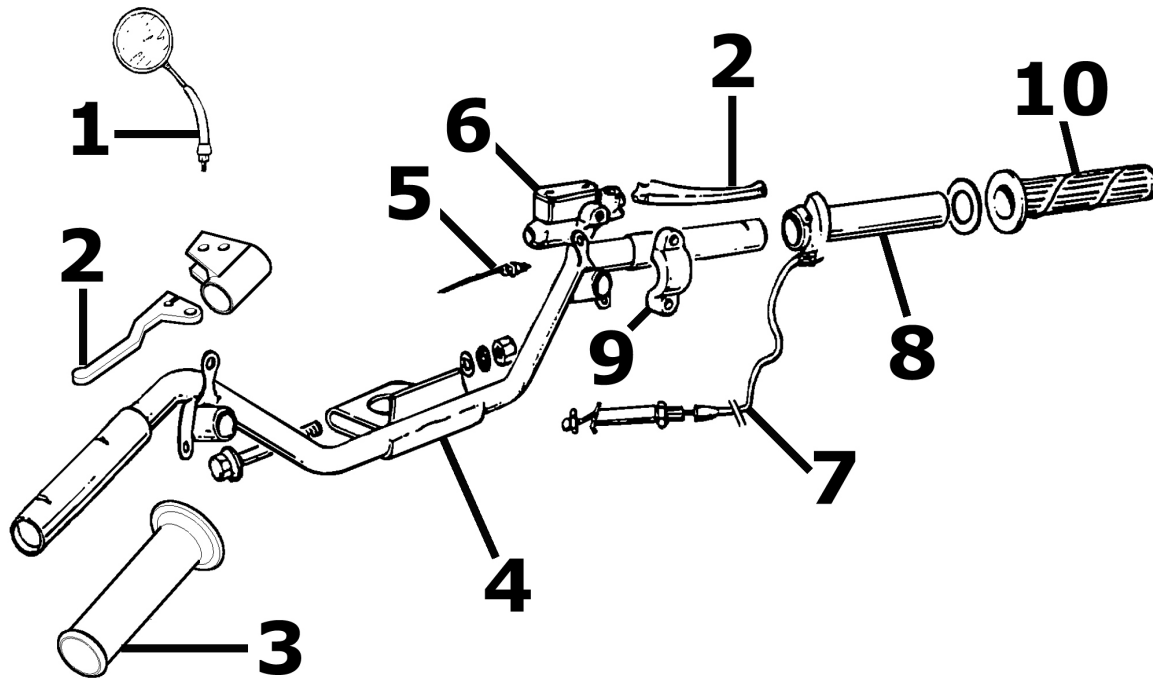

HANDLEBAR COMPONENTS

	Code	Action	Duration
1	004066	Rearview mirrors - Replacement	10'
2	002037	Complete gas control - Replacement	20'
3	002071	Left knob - Replacement	10'
4	003001	Handlebar - Removal and re-fitting	40'
5	005017	Stop light switch - Replacement	15'
6	002024	Brake pump - Removal and reinstallation	40'
7	002054	Throttle or splitter cable assembly - Replacement	40'
8	002060	Complete gas control - Replacement	15'
9	004162	Mirror U-bolt and/or brake pump fitting - Replacement	35'
10	002059	Right knob - Replacement	10'

Swing-arm

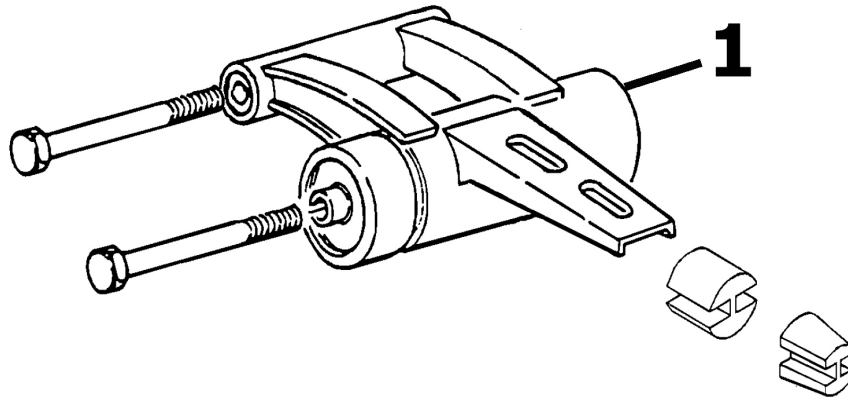

SWINGING ARM

	Code	Action	Duration
1	001072	Engine-frame connection swing arm - Replacement	60'

Seat

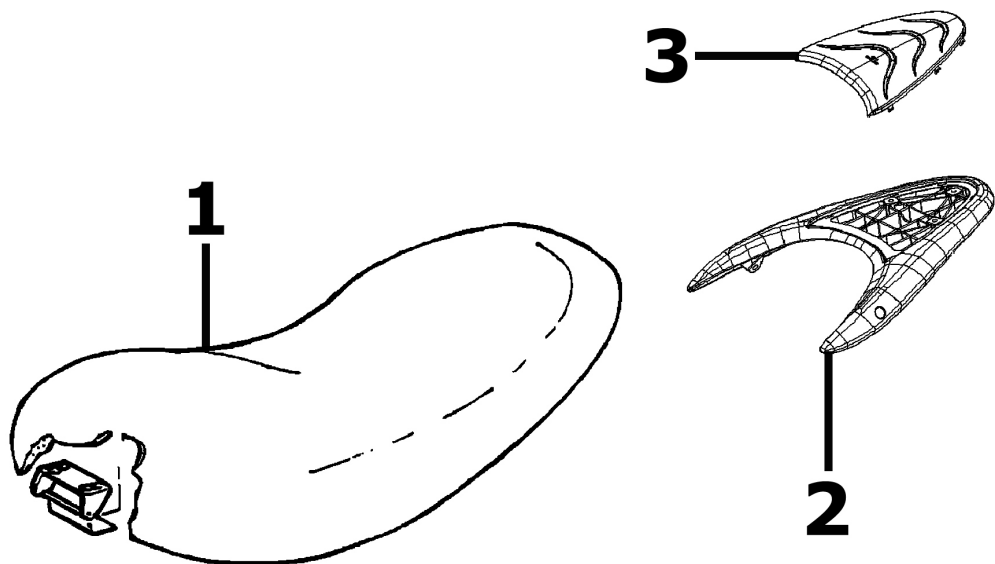

SADDLE

	Code	Action	Duration
1	004003	Saddle - Replacement	10'
2	004008	Carrier - replacement	10'
3	004062	Rear rack cover - Replacement	10'

Turn signal lights

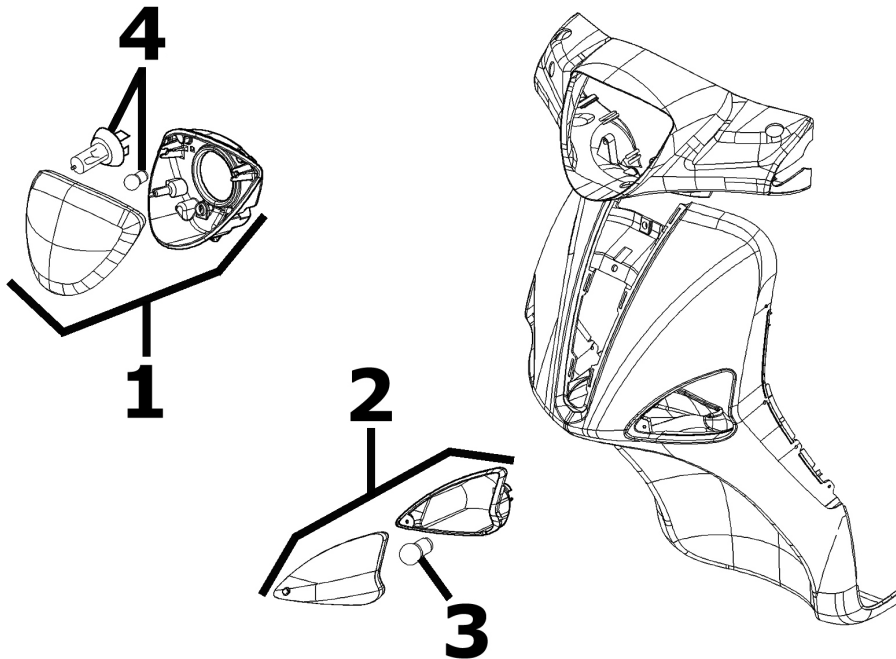

REAR RED LAMP

	Code	Action	Duration
1	005002	Headlight - Replacement	15'
2	005012	Front direction indicators - Replacement	15'
3	005067	Front direction indicator bulb - Replacement	10'
4	005008	Front headlights - Replacement	10'

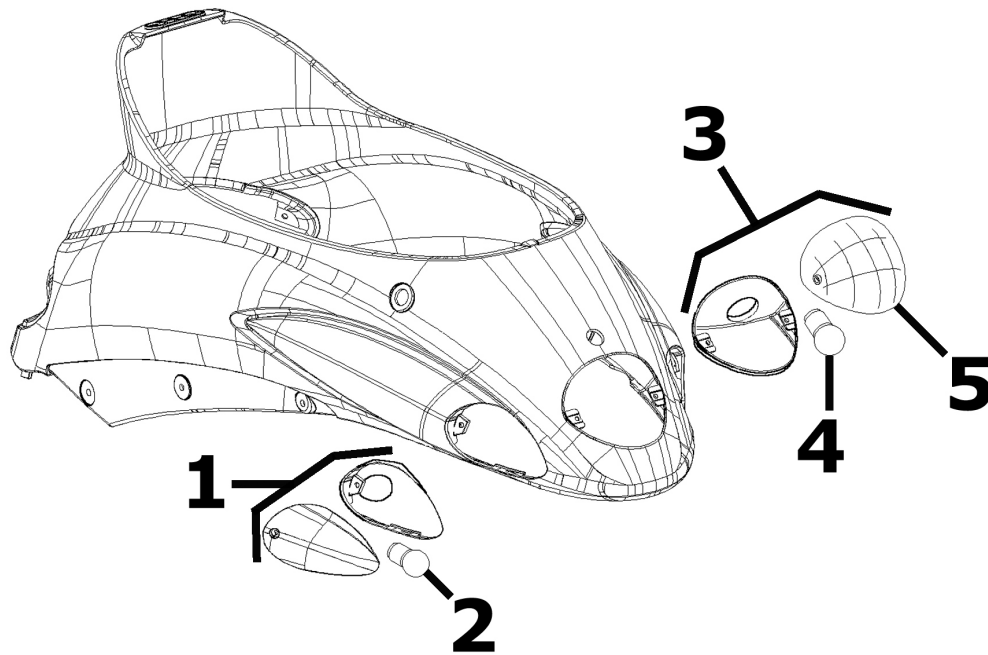

LAMP CLUSTER

	Code	Action	Duration
1	005022	Rear turn signal light- Replacement	15'
2	005068	Rear turn indicator bulb - Replacement	10'
3	005005	Taillight - Replacement	20'
4	005066	Rear light bulbs - Replacement	10'
5	005028	Rear optical unit glass - Replacement	10'

Front wheel

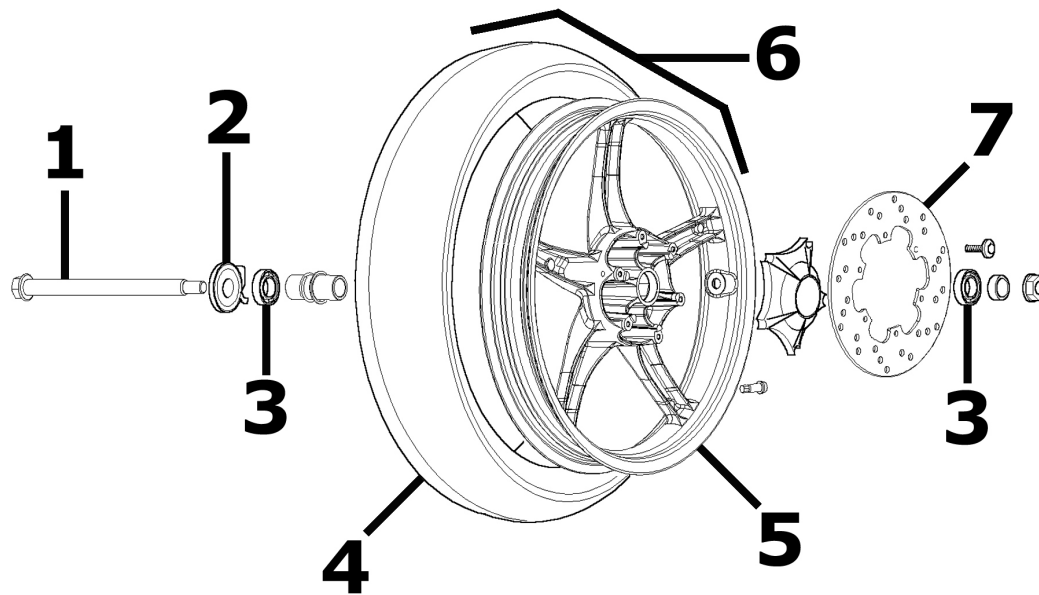

FRONT WHEEL

	Code	Action	Duration
1	003038	Front wheel spindle - Removal and refitting	45'
2	002011	Odometer drive gear - Replacement	30'
3	003040	Front wheel bearings - Replacement	50'
4	003047	Front tyre - Replacement	25'
5	003037	Front wheel rim - Removal and refitting	20'
6	004123	Front wheel - Replacement	25'
7	002041	Brake disc - Replacement	35'

Rear wheel

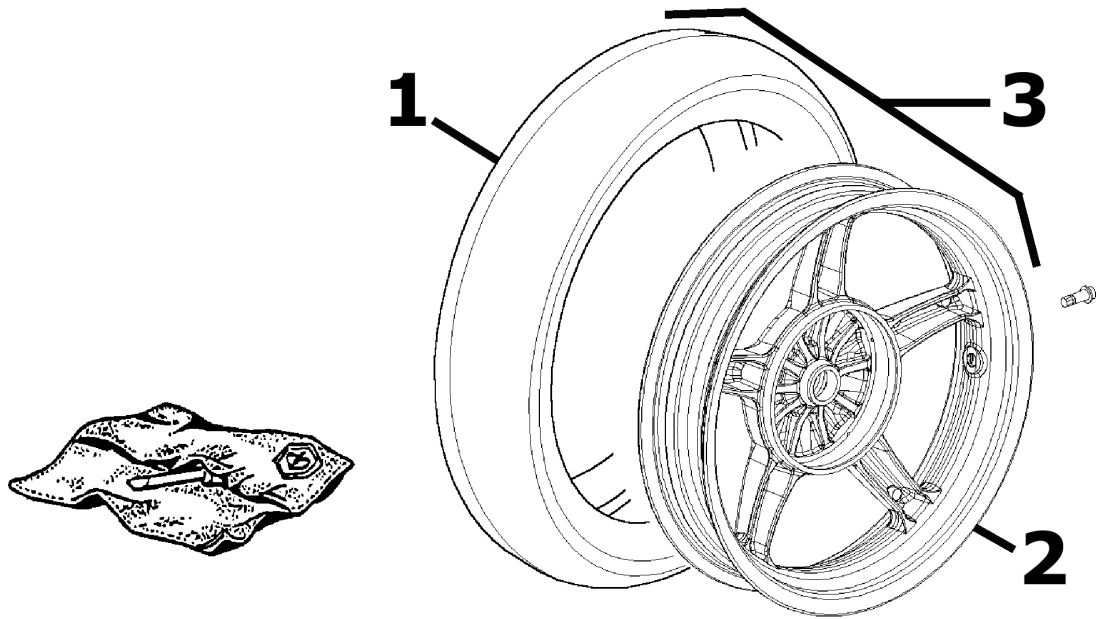

REAR WHEEL

	Code	Action	Duration
1	004126	Rear tyre - Replacement	40'
2	001071	Rear wheel rim - Removal and refitting	40'
3	001016	Rear wheel - Replacement	20'

Electric start

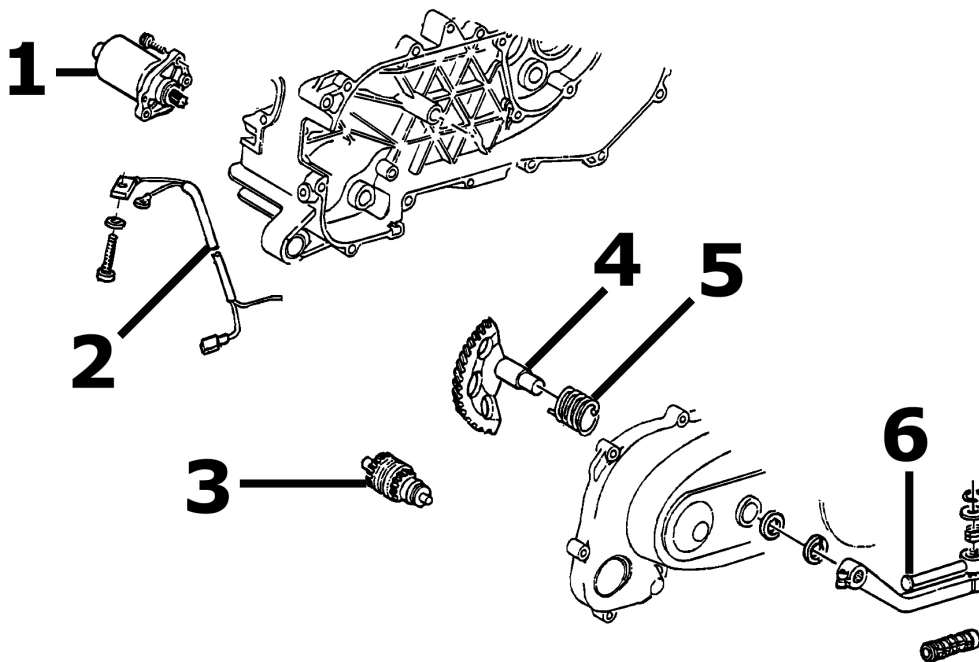

ELECTRIC START

	Code	Action	Duration
1	001020	Starter engine - Replacement	25'
2	005045	Starting motor cables - Replacement	20'
3	001017	Starter pinion - Replacement	25'
4	001021	Kick starter - Overhaul	25'
5	008008	Starting sector spring - Replacement	45'
6	001084	Starting lever - Replacement	10'

Electric devices

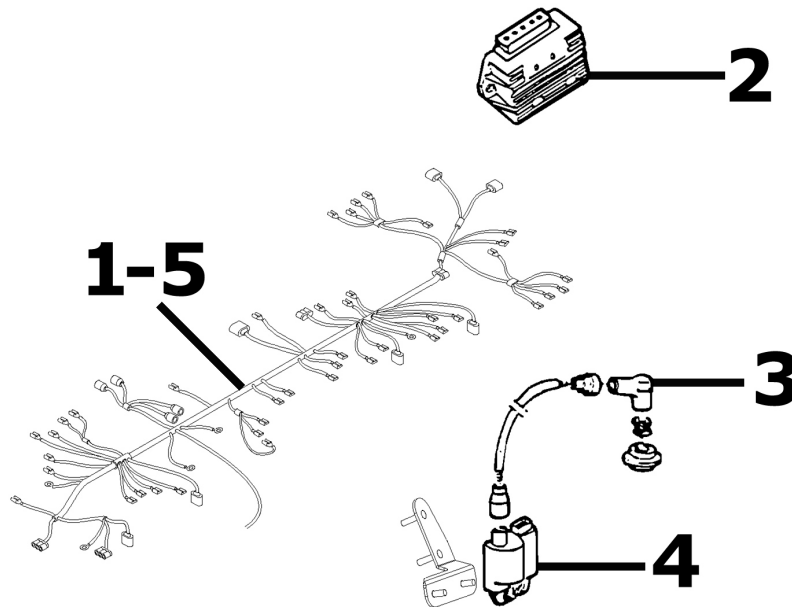

ELECTRIC DEVICES

	Code	Action	Duration
1	005001	Electric circuit - Replacement	140'
2	005009	Voltage regulator - Replacement	30'
3	001094	Spark plug cap - Replacement	10'
4	001023	Controller - Replacement	30'
5	005114	Electric circuit - Overhaul	30'

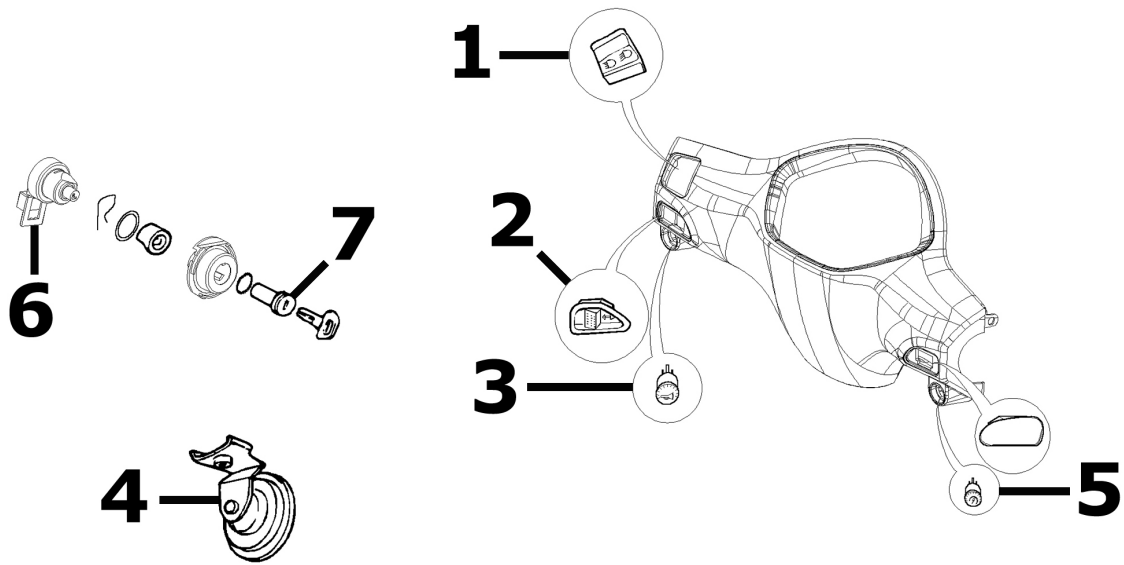

ELECTRICAL DEVICES

	Code	Action	Duration
1	005006	Light or flashing light switch - Replacement	25'
2	005039	Light switch - Replacement	25'
3	005040	Horn button - Replacement	25'
4	005003	Electric horn - Replacement	15'
5	005041	Starting device push button - Replacement	25'
6	005016	Key switch - Replacement	55'
7	004096	Locks series - Replacement	35'

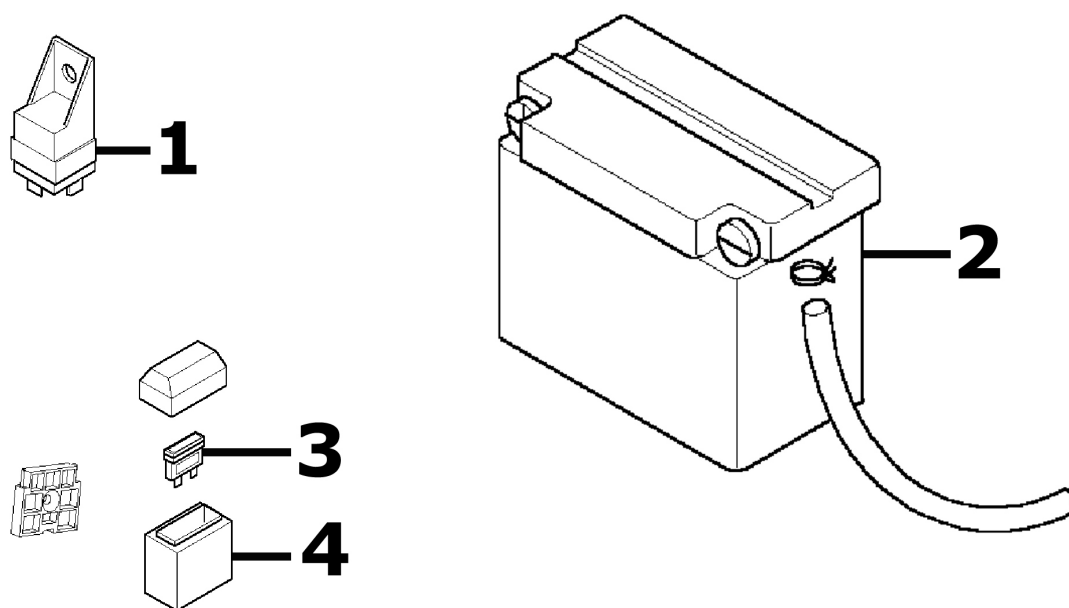

ELECTRICAL DEVICES

	Code	Action	Duration
1	005007	Battery - Replacement	15'
2	005011	Start-up remote control switch - Replacement	30'
3	005052	Fuse (1) - Replacement	20'
4	005054	Fuse carrier (1) - Replacement	10'

trasmissioni

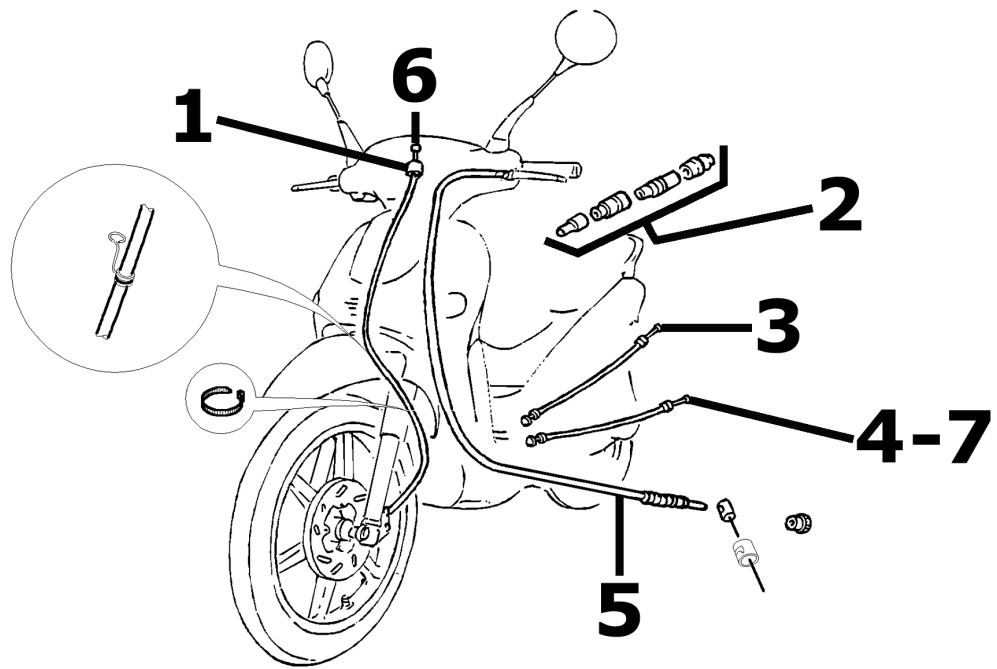

TRANSMISSIONS

	Code	Action	Duration
1	002051	Odometer transmissions assembly - Replacement	30'
2	002012	Splitter - Replacement	30'
3	002057	Splitter-carburettor cable assembly - Replacement	30'
4	002058	Mixer splitter cable assembly - Replacement	35'
5	002053	Rear brake transmissions assembly - Replacement	35'
6	002049	Odometer cable - Replacement	15'
7	003061	Throttle cable - Adjustment	5'

Brake callipers

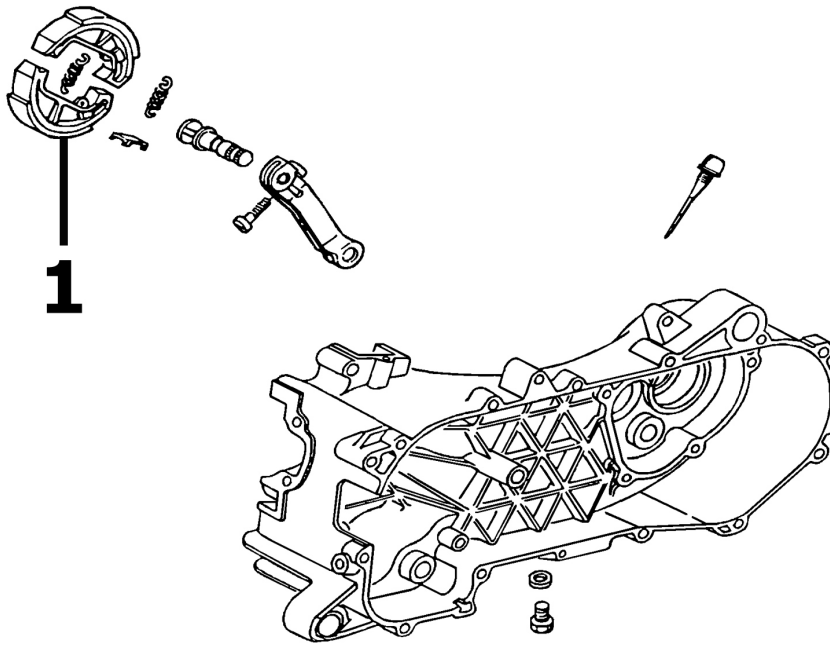

FRONT BRAKE CALIPER

	Code	Action	Duration
1	002002	Rear brake pads/shoes - Wear check	40'

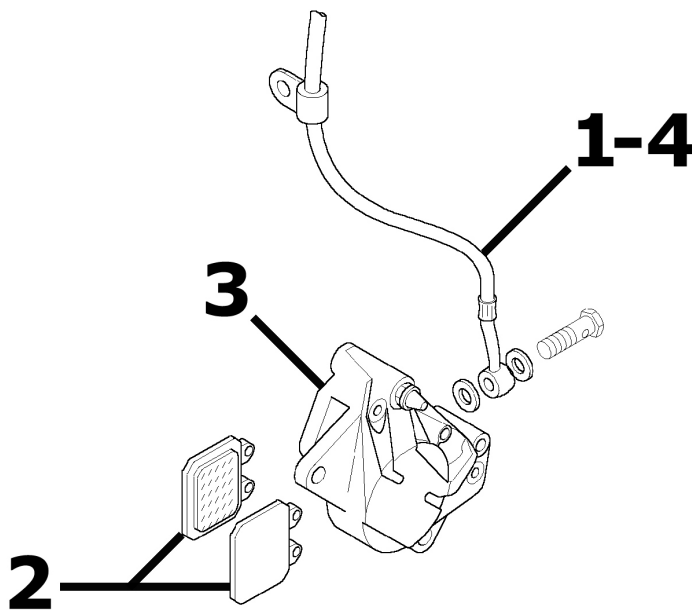

BRAKE LEVER

	Code	Action	Duration
1	002021	Front brake line - Replace-	45'

	Code	Action	Duration
		ment	
2	002007	Front brake shoes/pads - Removal and refitting	15'
3	002039	Front brake calliper - Removal and refitting	35'
4	002047	Front brake liquid and circuit bleeding - Replacement	50'

Front mudguard

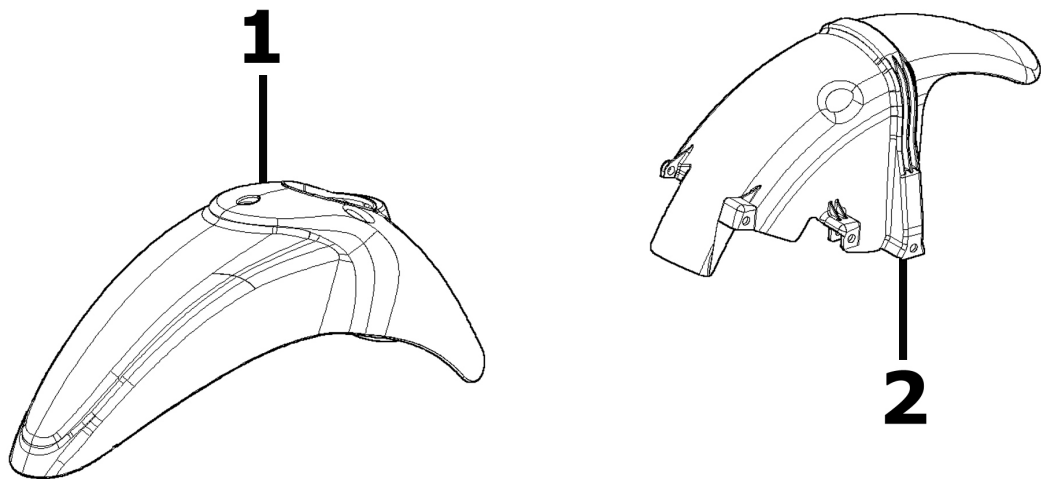

REAR MUDGUARD

	Code	Action	Duration
1	004009	Rear mudguard - Replacement	15'
2	004002	Front mudguard - Replacement	60'

Steering column

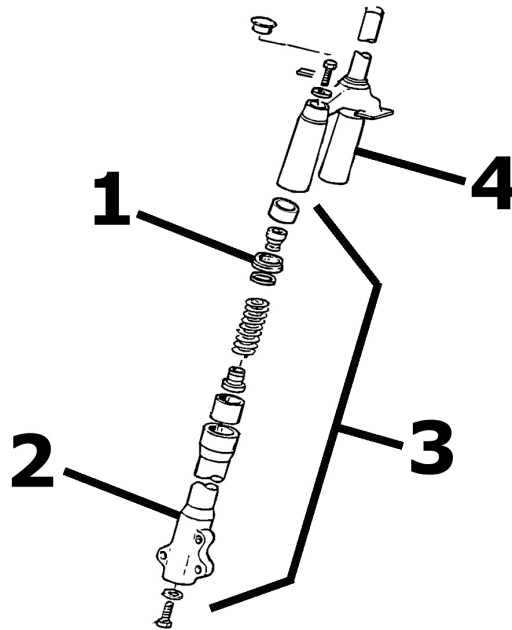

STEERING

	Code	Action	Duration
1	003048	Fork oil seal - Replacement	70'
2	003076	Fork leg - Replacement	70'
3	003079	Fork stanchion - Replacement	70'
4	003010	Front suspension - Overhaul	95'

Helmet bay

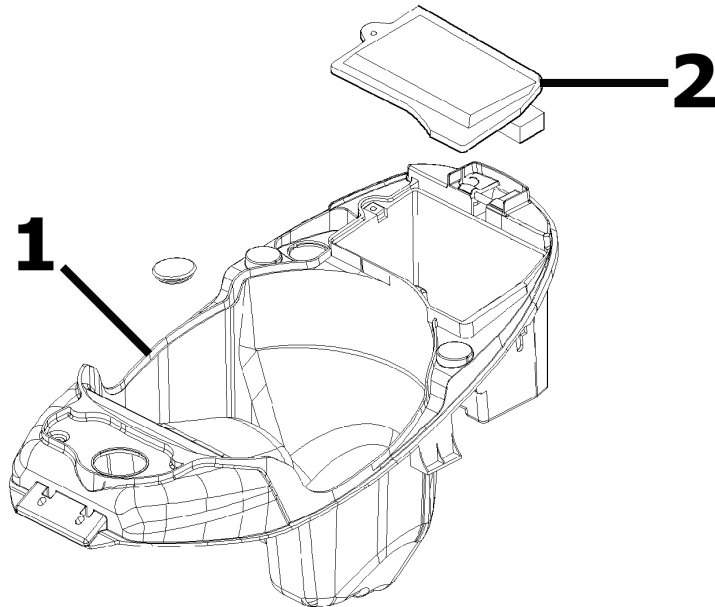

HELMET CARRIER

	Code	Action	Duration
1	004016	Helmet compartment - Disassembly and reassembly	35'
2	005046	Battery cover - Replacement	10'

Rear wheel axle

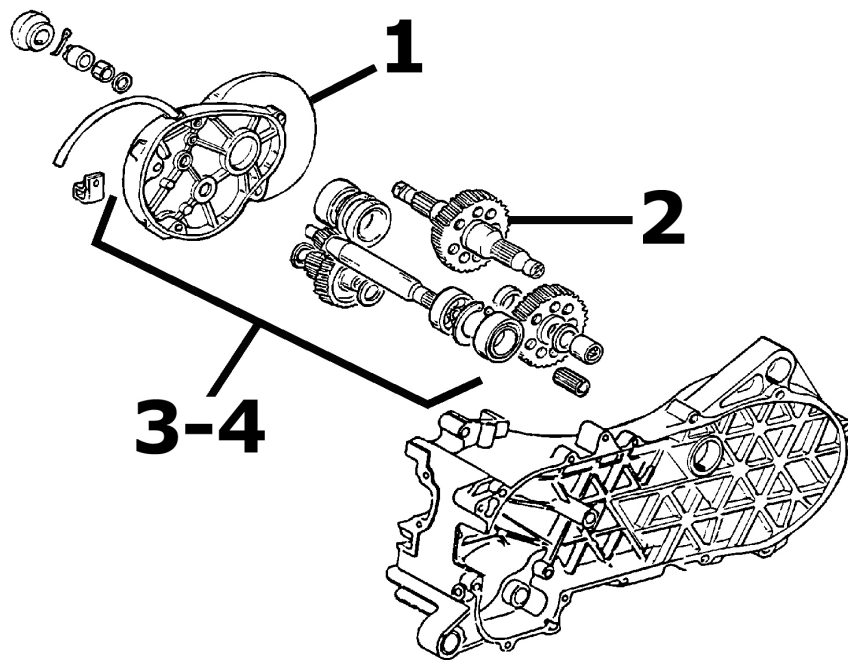

REAR WHEEL AXLE

	Code	Action	Duration
1	001156	Reduction gear cover - Replacement	30'
2	004125	Rear wheel axle - Replacement	30'
3	001010	Reduction gear - Overhaul	60'
4	003065	Gearcase oil - Replacement	20'

Secondary air box

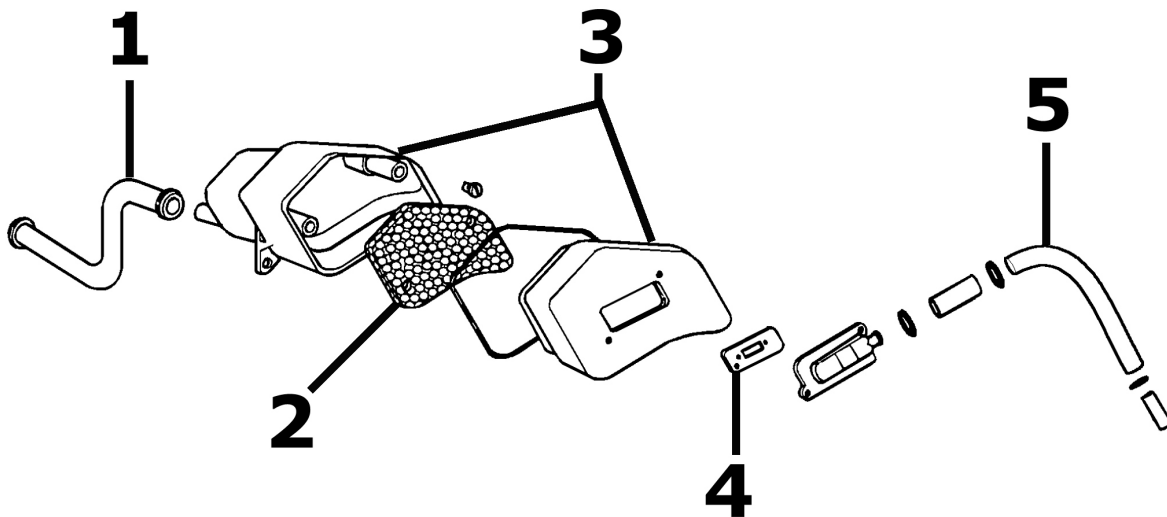

SECONDARY AIR BOX

	Code	Action	Duration
1	001164	Crankcase secondary air junction - Replacement	40'
2	001161	Secondary air filter- Replacement / Cleaning	15'
3	001162	Secondary air box - Replacement	40'
4	001163	Exhaust secondary air junction - Replacement	40'
5	001165	Secondary air valve - Replacement	15'