

## **MULTIMEDIA PROJECTOR**

**LV-7292A/LV-7297A  
LV-7298A/LV-7392A  
LV-7393A/LV-8227A  
LV-7292M/LV-7297M  
LV-8227M/LV-7392S  
LV-7292S/LV-7297S**

## **BASIC SERIAL**

## **COMMAND SPECIFICATIONS**

**Revision 1**

<b>Table of Contents</b>
--------------------------

<b>1</b>	<b>. Overview .....</b>	<b>1</b>
<b>2</b>	<b>. Serial Interface Specifications .....</b>	<b>2</b>
2.1.	Transfer Specifications .....	2
2.2.	Connection.....	2
<b>3</b>	<b>. Notes for Communication .....</b>	<b>3</b>
<b>4</b>	<b>. Functional Execution Command Table .....</b>	<b>4</b>
<b>5</b>	<b>. Status Read Command Table .....</b>	<b>6</b>
<b>6</b>	<b>. Functional Execution Command.....</b>	<b>7</b>
6.1.	Format .....	7
6.2.	Command Pipelining .....	7
6.3.	Transfer Example.....	7
6.4.	Operation Requirements.....	8
6.5.	POWER ON Command .....	9
6.6.	POWER OFF Command (Quick Power OFF) .....	9
6.7.	POWER OFF Command .....	9
6.8.	HDMI Command (Except LV-7292S/LV-7297S/LV-7392S ) .....	9
6.9.	Computer Command.....	9
6.10.	Video Command .....	10
6.11.	VOLUME + Command (Except LV-7292S/ LV-7297S/ LV-7392S) .....	10
6.12.	VOLUME – Command (Except LV-7292S/ LV-7297S/ LV-7392S) .....	10
6.13.	AUDIO MUTE ON Command (Except LV-7292S/ LV-7297S/ LV-7392S).....	10
6.14.	AUDIO MUTE OFF Command (Except LV-7292S/ LV-7297S/ LV-7392S)....	10
6.15.	VIDEO MUTE ON Command .....	11
6.16.	VIDEO MUTE OFF Command.....	11
6.17.	Aspect Normal size Command.....	11
6.18.	Aspect 16:9 size Command (LV-8227A/LV-8227M) .....	11
6.19.	Screen Full size Command .....	11
6.20.	Image Standard Command.....	11
6.21.	Image High contrast Command .....	12
6.22.	Image Cinema Command .....	12
6.23.	User 1 Command.....	12
6.24.	User 2 Command.....	12
6.25.	User 3 Command.....	12
6.26.	User 4 Command.....	12
6.27.	Image Blackboard (Green) Command.....	12
6.28.	Image Presentation Command.....	13
6.29.	MENU ON Command.....	13
6.30.	MENU OFF Command .....	13
6.31.	DISPLAY CLEAR Command.....	13
6.32.	BRIGHTNESS + Command.....	13
6.33.	BRIGHTNESS – Command.....	13
6.34.	IMAGE (Toggle) Command.....	14
6.35.	Direct power on Setting Command .....	14
6.36.	Direct power on Cancel Command.....	14
6.37.	Power management mode Standby Command.....	14
6.38.	Power Management mode OFF Command .....	14
6.39.	Power management mode Exit Command.....	14

6.40.	D.ZOOM + Command .....	15
6.41.	D.ZOOM – Command.....	15
6.42.	Computer S-Video Command .....	15
6.43.	Image Colorboard Command.....	15
6.44.	POINTER RIGHT Command .....	15
6.45.	POINTER LEFT Command.....	16
6.46.	POINTER UP Command .....	16
6.47.	POINTER DOWN Command .....	16
6.48.	OK Command.....	16
6.49.	FREEZE ON Command .....	16
6.50.	FREEZE OFF Command .....	17
6.51.	Computer Analog RGB Command.....	17
6.52.	Computer Scart Command .....	17
6.53.	Computer Component Command.....	17
6.54.	AUTO PC Command.....	17
6.55.	PRESENTATION TIMER Command.....	18
6.56.	PRESENTATION TIMER (Exit) Command .....	18
6.57.	KEYSTONE ↑Command.....	18
6.58.	KEYSTONE ↓Command.....	18

## **7 . Status Read Command ..... 19**

7.1.	Format .....	19
7.2.	Transfer Example.....	19
7.3.	Operation Requirements.....	19
7.4.	Status Read Command .....	19
7.5.	Input Mode Read Command.....	22
7.6.	Lamp Time Read Command .....	22
7.7.	Setting Read Command .....	22
7.8.	Temp Read Command .....	22
7.9.	Lamp Mode Read Command .....	23

## 1 . Overview

- 1.1. These specifications define projector control commands for LV-7292A/7297A/7392A/7393A/7398A/  
8227A/7292M/7297M/8227M/7292S/7297S/7392S
  
- 1.2. The projector control commands are used to remotely control a projector through RS-232C from a  
computer.

## 2 . Serial Interface Specifications

### 2.1. Transfer Specifications

Item	Specifications
Synchronous system	Asynchronous
Transmission Speed	9600 / 19200
Data Length	8 bit
Parity	N/A
Stop Bit	1
Flow Control	N/A

- 1) Transmission speed: initial setting value is 19200.
- 2) Transmission speed can be changed in service mode.

### 2.2. Connection

Dedicated serial cable must be used for connection to a computer and a projector.

Dedicated serial cable must be used for connection to a computer and a projector.

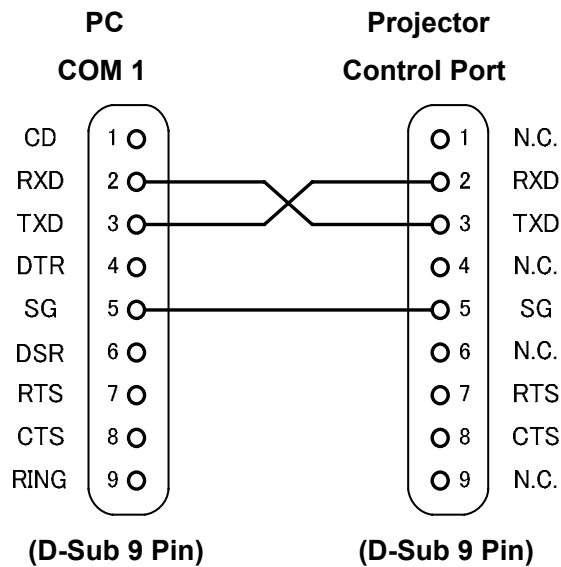

### 3 . Notes for Communication

**3.1.** The projector control command is defined as one command/one line that starts with “C” and ends with carriage return (0x0D).

**3.2.** There are two types of Commands: Functional Execution Commands and Status Read Commands.

Example of Functional Execution Command: “C05” [CR]

Example of Status Read Command: “CR0” [CR]

**3.3.** When it takes more than one second to receive one command, it does not operate.

The information of buffer is cleared when it takes more than one second to receive carriage return (0x0D) after the projector receives the first data “C”.

**3.4.** For Command pipelining, wait for the interval of 100ms after receiving a response.

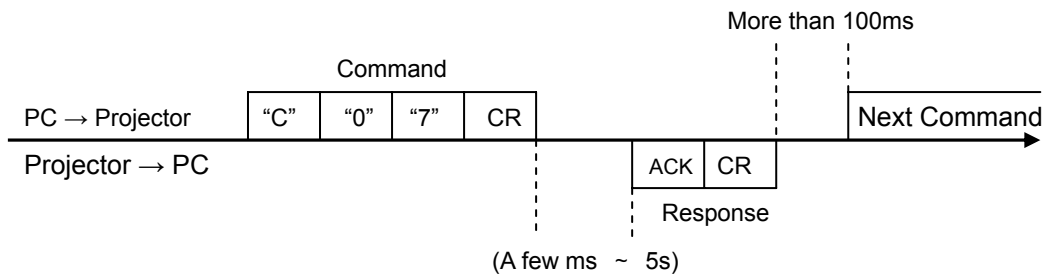

**3.4.1.** When a command is issued before receiving a response, the function is not executed properly.

**3.4.2.** Except for when there is no Response for more than 5 seconds.

**3.5.** It takes about 5 seconds for internal initialization after plugging in AC power. During this time, it cannot process commands. Do not issue any command.

**3.6.** The number of characters of response to Status Read Commands depends on commands.

Please see [7. Status Read Commands].

**3.7.** Characters for commands must be Capital (A - Z).

4 . Functional Execution Command Table

Command	Item	Command	Item
C00	POWER ON	C20	BRIGHTNESS +
C01	POWER OFF (Quick Power OFF)	C21	BRIGHTNESS -
C02	POWER OFF	C22	-----
C03	-----	C23	-----
C04	HDMI	C24	-----
C05	Computer	C25	-----
C06	-----	C26	-----
C07	Video	C27	IMAGE (Toggle)
C08	-----	C28	Direct power on Enable
C09	VOLUME +	C29	Direct power on Disable
C0A	VOLUME -	C2A	Power management mode Standby
C0B	AUDIO MUTE ON	C2B	Power Management mode OFF
C0C	AUDIO MUTE OFF	C2C	-----
C0D	VIDEO MUTE ON	C2D	-----
C0E	VIDEO MUTE OFF	C2E	Power management mode Exit
C0F	Aspect Normal size	C2F	-----
C10	Aspect 16 : 9 size	C30	D.ZOOM +
C10	Aspect Full size		
C11	Image Standard	C31	D.ZOOM -
C12	High Contrast	C32	-----
C13	Image Cinema	C33	-----
C14	User 1	C34	Computer S-video
C15	User 2	C35	-----
C16	User 3	C36	-----
C17	User 4	C37	-----
C18	Blackboard	C38	-----
C19	Presentation	C39	Image Colorboard
C1A	-----	C3A	POINTER RIGHT
C1B	-----	C3B	POINTER LEFT
C1C	MENU ON	C3C	POINTER UP
C1D	MENU OFF	C3D	POINTER DOWN
C1E	DISPLAY CLEAR	C3E	-----
C1F	-----	C3F	OK

----- means no function.

Command	Item	Command	Item
C40	-----	C80	-----
C41	-----	C81	-----
C42	-----	C82	-----
C43	FREEZE ON	C83	-----
C44	FREEZE OFF	C84	-----
C45	-----	C85	-----
C46	-----	C86	-----
C47	-----	C87	-----
C48	-----	C88	-----
C49	-----	C89	Auto PC
C4A	-----	C8A	PRESENTATION TIMER
C4B	-----	C8B	PRESENTATION TIMER(Exit)
C4C	-----	C8C	-----
C4D	-----	C8D	-----
C4E	-----	C8E	KEystone ↑
C4F	-----	C8F	KEystone ↓
C50	Computer Analog RGB	C90	-----
C51	Computer Scart	C91	-----
C52	-----	C92	-----
C53	-----	C93	-----
C54	Computer Component	C94	-----
C55	-----	C95	-----
C56	-----	C96	-----
C57	-----	C97	-----
C58	-----	C98	-----
C59	-----	C99	-----
C5A	-----	C9A	-----
C5B	-----	C9B	-----
C5C	-----	C9C	-----

----- means no function.



## 5 . Status Read Command Table

Command	Item	Memo
CR0	Status Read	
CR1	Input Mode Read	
CR2	-----	
CR3	(Corresponding) Lamp Time Read	
CR4	Setting Read	
CR5	-----	
CR6	Temp Read	
CR7	Lamp Mode Read	

----- means no function.

## 6 . Functional Execution Command

### 6.1. Format

6.1.1 PC issues a command in format as below.

“C” **COMMAND** [CR]

Command: two characters (See Basic Functional Execution Command Table)

A projector changes received data to decode and returns a result after being ready to receive next command.

**[ACK][CR]** : (0x06, 0x0D)When received Functional Execution Commands.

6.1.2 “?”[CR] :When the received data cannot be decoded.

### 6.2. Command Pipelining

When some functions need the command pipelining, the performance is the same as that of the remote control;

6.2.1. System: issues any command every 100 ms.

6.2.2. When receiving the appropriate command, the function is executed for 120 ms from the moment.

6.2.3. When receiving the same command continuously within 120 ms, the function is executed for another 120 ms from the moment.

6.2.4. When there is no incoming command after 120 ms, the execution of pipelining is stopped.

6.2.5. When the projector receives other incoming commands within 120ms, the execution of pipelining is stopped.

### 6.3. Transfer Example

Switch the projector to video mode with Basic Command.

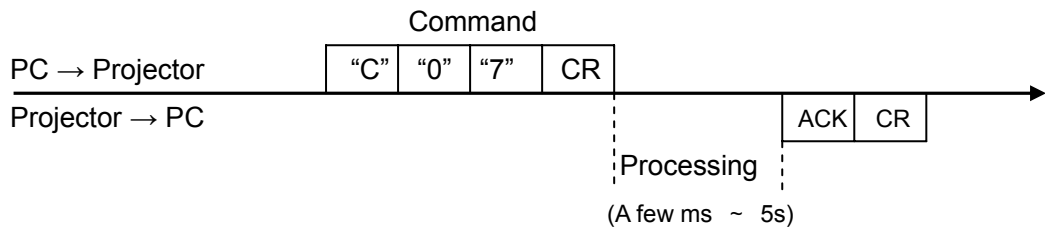

#### 6.4. Operation Requirements

1) When the projector's status is any of below, Functional Execution Commands are limited.

Projector Status	Available Functional Execution Commands
In Standby	C00:POWER ON
Countdown in process	C00:POWER ON → Countdown is terminated C01:POWER OFF C02:POWER OFF → Countdown is terminated
Cooling Down in process	NONE (No Execution)
Cooling Down due to Abnormal Temperature	NONE (No Execution)
Abnormal Temperature Status	NONE (No Execution)
Abnormal Power Status	NONE (No Execution)
Power Save / Cooling Down in process	NONE (No Execution)
Power Save Status	C00:POWER ON C01:POWER OFF
Auto input : On1/On2 setting	Although transmit Input source commands, Auto input does not operate.

Note) When the status is as above, even if the projector receives other commands, it returns **[ACK] [CR]**.

2) When Eco mode is selected in Standby mode of Setting menu and projector is in Standby, Functional Execution Commands are invalid.

### 6.5. POWER ON Command

Command	"C00" [CR]	
Detail	Power ON When already Power is ON, nothing is done. When sending this command during processing Countdown, Countdown is terminated.	
Response	Acceptable	[ACK] [CR]
	Unacceptable	" ? "[CR]

### 6.6. POWER OFF Command (Quick Power OFF)

Command	"C01" [CR]	
Detail	Power OFF (Standby) When Power is OFF with ON/STAND-BY button of the projector and remote control, "Power OFF?" is displayed. However, as soon as this command is sent, Quick Power OFF is executed.	
Response	Acceptable	[ACK] [CR]
	Unacceptable	" ? "[CR]

### 6.7. POWER OFF Command

Command	"C02" [CR]	
Detail	Power OFF (Standby). The command operates the same Power OFF function as ON/STAND-BY button of the projector and remote control. Once this command is sent, "Power OFF?" is displayed. If this command is sent again while it is displayed, Power OFF is executed. When sending this command during Countdown, Countdown is terminated.	
Response	Acceptable	[ACK] [CR]
	Unacceptable	" ? "[CR]

### 6.8.HDMI Command (Except LV-7292S/LV-7297S/LV-7392S )

Command	"C04" [CR]	
Detail	Select HDMI Input Although projector returns "OK", Auto input is not executed with this command while Auto input is set to On1/On2.	
Response	Acceptable	[ACK] [CR]
	Unacceptable	" ? "[CR]

### 6.9.Computer Command

Command	"C05" [CR]	
Detail	Select Computer Input Although projector returns "OK", Auto input is not executed with this command while Input search is set to On1 or On2,	
Response	Acceptable	[ACK] [CR]
	Unacceptable	" ? "[CR]

### 6.10. Video Command

Command	"C07" [CR]	
Detail	Select Video Input Although projector returns "OK", Auto input is not executed with this command while Input search is set to On1 or On2,	
Response	Acceptable	[ACK] [CR]
	Unacceptable	" ? "[CR]

### 6.11. VOLUME + Command (Except LV-7292S/ LV-7297S/ LV-7392S)

Command	"C09" [CR]	
Detail	Volume Up. This command operates the same way as "VOLUME+" button of the projector and remote control2	
Response	Acceptable	[ACK] [CR]
	Unacceptable	" ? "[CR]

### 6.12. VOLUME – Command (Except LV-7292S/ LV-7297S/ LV-7392S)

Command	"C0A" [CR]	
Detail	Volume Down This command operates the same way as "VOLUME-" button of the projector and remote control.	
Response	Acceptable	[ACK] [CR]
	Unacceptable	" ? "[CR]

### 6.13. AUDIO MUTE ON Command (Except LV-7292S/ LV-7297S/ LV-7392S)

Command	"C0B" [CR]	
Detail	Sound Mute ON. This command works the same way as "MUTE" button of the remote control for Mute ON, but does not work for Mute OFF.	
Response	Acceptable	[ACK] [CR]
	Unacceptable	" ? "[CR]

### 6.14. AUDIO MUTE OFF Command (Except LV-7292S/ LV-7297S/ LV-7392S)

Command	"C0C" [CR]	
Detail	Sound Mute OFF. This command works the same way as "MUTE" button of the remote control for Mute OFF, but does not work for Mute ON.	
Response	Acceptable	[ACK] [CR]
	Unacceptable	" ? "[CR]

### 6.15. VIDEO MUTE ON Command

Command	"C0D"[CR]	
Detail	Video Mute ON. This command works the same way as "BLANK" button of the remote control for Blank ON, but does not work for Blank OFF.	
Response	Acceptable	[ACK] [CR]
	Unacceptable	" ? "[CR]

### 6.16. VIDEO MUTE OFF Command

Command	"C0E" [CR]	
Detail	Video Mute OFF. This command works the same way as "BLANK" button of remote control for Blank OFF, but does not work for Blank ON.	
Response	Acceptable	[ACK] [CR]
	Unacceptable	" ? "[CR]

### 6.17. Aspect Normal size Command

(LV-7292A/LV-7297A/ LV-7392A/ LV-7393A/ LV-7292M/ LV-7297M/ LV-8227M)

Command	"C0F" [CR]	
Detail	Set Aspect mode to Normal. This command is invalid while D.Zoom is in operation.	
Response	Acceptable	[ACK] [CR]
	Unacceptable	" ? "[CR]

### 6.18. Aspect 16:9 size Command (LV-8227A/LV-8227M)

Command	"C10" [CR]	
Detail	Set Aspect mode to 16:9. This command is invalid while D.Zoom is in operation.	
Response	Acceptable	[ACK] [CR]
	Unacceptable	" ? "[CR]

### 6.19. Screen Full size Command

Command	"C10" [CR]	
Detail	Set Aspect mode to Full. This command is valid though D.Zoom is in operation.	
Response	Acceptable	[ACK] [CR]
	Unacceptable	" ? "[CR]

### 6.20. Image Standard Command

Command	"C11" [CR]	
Detail	Set image to Standard mode.	
Response	Acceptable	[ACK] [CR]
	Unacceptable	" ? "[CR]

### 6.21. Image High contrast Command

Command	"C12" [CR]	
Detail	Set image to High contrast mode.	
Response	Acceptable	[ACK] [CR]
	Unacceptable	" ? "[CR]

### 6.22. Image Cinema Command

Command	"C13" [CR]	
Detail	Set image to Cinema mode.	
Response	Acceptable	[ACK] [CR]
	Unacceptable	" ? "[CR]

### 6.23. User 1 Command

Command	"C14" [CR]	
Detail	Set image to User 1 mode.	
Response	Acceptable	[ACK] [CR]
	Unacceptable	" ? "[CR]

### 6.24. User 2 Command

Command	"C15" [CR]	
Detail	Set image to User 2 mode.	
Response	Acceptable	[ACK] [CR]
	Unacceptable	" ? "[CR]

### 6.25. User 3 Command

Command	"C16" [CR]	
Detail	Set image to User 3 mode.	
Response	Acceptable	[ACK] [CR]
	Unacceptable	" ? "[CR]

### 6.26. User 4 Command

Command	"C17" [CR]	
Detail	Set image to User 4 mode.	
Response	Acceptable	[ACK] [CR]
	Unacceptable	" ? "[CR]

### 6.27. Image Blackboard (Green) Command

Command	"C18" [CR]	
Detail	Set image to Blackboard (Green) mode.	
Response	Acceptable	[ACK] [CR]
	Unacceptable	" ? "[CR]

### 6.28. Image Presentation Command

Command	"C19" [CR]	
Detail	Set image to Presentation mode.	
Response	Acceptable	[ACK] [CR]
	Unacceptable	" ? "[CR]

### 6.29. MENU ON Command

Command	"C1C" [CR]	
Detail	Display On-Screen Display Menu.	
Response	Acceptable	[ACK] [CR]
	Unacceptable	" ? "[CR]

### 6.30. MENU OFF Command

Command	"C1D" [CR]	
Detail	Hide On-Screen Display Menu.	
Response	Acceptable	[ACK] [CR]
	Unacceptable	" ? "[CR]

### 6.31. DISPLAY CLEAR Command

Command	"C1E" [CR]	
Detail	Hide On-Screen Display. Hide On-Screen Display unconditionally.	
Response	Acceptable	[ACK] [CR]
	Unacceptable	" ? "[CR]

### 6.32. BRIGHTNESS + Command

Command	"C20" [CR]	
Detail	Brightness of User Control +1.	
Response	Acceptable	[ACK] [CR]
	Unacceptable	" ? "[CR]

### 6.33. BRIGHTNESS – Command

Command	"C21" [CR]	
Detail	Brightness of User Control –1.	
Response	Acceptable	[ACK] [CR]
	Unacceptable	" ? "[CR]



### 6.34. IMAGE (Toggle) Command

Command	"C27"[CR]	
Detail	Switch Image Setting status. This command works the same way as "IMAGE" button of the remote control.	
Response	Acceptable	[ACK] [CR]
	Unacceptable	" ? "[CR]

### 6.35. Direct power on Setting Command

Command	"C28" [CR]	
Detail	Enable Direct power on function. This status is stored in EEPROM and retained regardless of Power OFF/ON.	
Response	Acceptable	[ACK] [CR]
	Unacceptable	" ? "[CR]

### 6.36. Direct power on Cancel Command

Command	"C29" [CR]	
Detail	Cancel Direct power on function. This status is stored in EEPROM and retained regardless of Power OFF/ON.	
Response	Acceptable	[ACK] [CR]
	Unacceptable	" ? "[CR]

### 6.37. Power management mode Standby Command

Command	"C2A" [CR]	
Detail	Set Power Management mode to Standby mode. This status is stored in EEPROM and retained regardless of Power ON/OFF.	
Response	Acceptable	[ACK] [CR]
	Unacceptable	" ? "[CR]

### 6.38. Power Management mode OFF Command

Command	"C2B" [CR]	
Detail	Set Power Management mode to OFF mode. This status is stored in EEPROM and retained regardless of Power ON/OFF.	
Response	Acceptable	[ACK] [CR]
	Unacceptable	" ? "[CR]

### 6.39. Power management mode Exit Command

Command	"C2E" [CR]	
Detail	Set Power Management mode to Exit mode. This status is stored in EEPROM and retained regardless of Power OFF/ON.	
Response	Acceptable	[ACK] [CR]
	Unacceptable	" ? "[CR]

#### 6.40. D.ZOOM + Command

Command	"C30" [CR]	
Detail	Enter Digital Zoom mode and expand image size. This command works the same way as "D.ZOOM +" button of the remote control.	
Response	Acceptable	[ACK] [CR]
	Unacceptable	" ? "[CR]

#### 6.41. D.ZOOM - Command

Command	"C31" [CR]	
Detail	Enter Digital Zoom mode and reduce image size. This command works the same as "D.ZOOM -" button of the remote control.	
Response	Acceptable	[ACK] [CR]
	Unacceptable	" ? "[CR]

#### 6.42. Computer S-Video Command

Command	"C34" [CR]	
Detail	Select S-Video of Computer input. Although projector returns "OK", Auto input is not executed with this command while Auto input is set to On1 or On2,	
Response	Acceptable	[ACK] [CR]
	Unacceptable	" ? "[CR]

#### 6.43. Image Colorboard Command

Command	"C39" [CR]	
Detail	Set image to Colorboard mode.	
Response	Acceptable	[ACK] [CR]
	Unacceptable	" ? "[CR]

#### 6.44. POINTER RIGHT Command

Command	"C3A" [CR]	
Detail	Move the Pointer of On-Screen Display Menu to the right. This command works differently from the pointer ">" of the projector and remote control, and has no function of Volume +. LV-7292S/7297S/7392S: Move the Pointer of On-Screen Display Menu to the right. This command is the same behavior as the point button ">" of the projector	
Response	Acceptable	[ACK] [CR]
	Unacceptable	" ? "[CR]

#### 6.45. POINTER LEFT Command

Command	"C3B" [CR]	
Detail	Move the Pointer of On-Screen Display Menu to the left. This command works differently from the pointer "<" of the projector and remote control, and has no function of Volume +. LV-7292S/7297S/7392S: Move the Pointer of On-Screen Display Menu to the left. This command is the same behavior as the point button "<" of the projector	
Response	Acceptable	[ACK] [CR]
	Unacceptable	" ? "[CR]

#### 6.46. POINTER UP Command

Command	"C3C" [CR]	
Detail	Move up the Pointer of On-Screen Display Menu. This command works the same way as the pointer "▲" of the projector.	
Response	Acceptable	[ACK] [CR]
	Unacceptable	" ? "[CR]

#### 6.47. POINTER DOWN Command

Command	"C3D" [CR]	
Detail	Move down the Pointer of On-Screen Display Menu. This command works the same way as the pointer "▼" of the projector.	
Response	Acceptable	[ACK] [CR]
	Unacceptable	" ? "[CR]

#### 6.48. OK Command

Command	"C3F" [CR]	
Detail	This command works the same way as "OK" button of the projector and remote control.	
Response	Acceptable	[ACK] [CR]
	Unacceptable	" ? "[CR]

#### 6.49. FREEZE ON Command

Command	"C43" [CR]	
Detail	Freeze on-screen image. This command works the same way as "FREEZE" button of the remote control for Freeze ON, but does not work for Freeze OFF.	
Response	Acceptable	[ACK] [CR]
	Unacceptable	" ? "[CR]

### 6.50. FREEZE OFF Command

Command	"C44" [CR]	
Detail	Cancel Freeze mode. This command works the same way as "FREEZE" button of the remote control for Freeze OFF, but does not work for Freeze ON.	
Response	Acceptable	[ACK] [CR]
	Unacceptable	" ? "[CR]

### 6.51. Computer Analog RGB Command

Command	"C50" [CR]	
Detail	Select Analog RGB input in Computer . Although projector returns "OK", Auto input is not executed with this command while Input Auto input set to On1 or On2,	
Response	Acceptable	[ACK] [CR]
	Unacceptable	" ? "[CR]

### 6.52. Computer Scart Command

Command	"C51" [CR]	
Detail	Select Scart input in Computer. Although projector returns "OK", Auto input is not executed with this command while Auto input is set to On1 or On2,	
Response	Acceptable	[ACK] [CR]
	Unacceptable	" ? "[CR]

### 6.53. Computer Component Command

Command	"C54" [CR]	
Detail	Select Component input in Computer . Although projector returns "OK", Auto input is not executed with this command while Auto input is set to On1 or On2,	
Response	Acceptable	[ACK] [CR]
	Unacceptable	" ? "[CR]

### 6.54. AUTO PC Command

Command	"C89" [CR]	
Detail	Execute Auto PC function. This command operates the same as "Auto PC" of main menu. Projector suspends Auto PC operation when receiving this command another time.	
Response	Acceptable	[ACK] [CR]
	Unacceptable	" ? "[CR]

### 6.55. PRESENTATION TIMER Command

Command	"C8A" [CR]	
Detail	Execute P- timer. This command works the same way as "P-TIMER" button of the remote control.	
Response	Acceptable	[ACK] [CR]
	Unacceptable	" ? "[CR]

### 6.56. PRESENTATION TIMER (Exit) Command

Command	"C8B" [CR]	
Detail	Exit P- timer menu. This command works the same as holding on the "P-TIMER" button of the remote control	
Response	Acceptable	[ACK] [CR]
	Unacceptable	" ? "[CR]

### 6.57. KEYSTONE ↑ Command

Command	"C8E" [CR]	
Detail	Correct keystone distortion by reducing upper part of image.	
Response	Acceptable	[ACK] [CR]
	Unacceptable	" ? "[CR]

### 6.58. KEYSTONE ↓ Command

Command	"C8F" [CR]	
Detail	Correct keystone distortion by reducing down part of image.	
Response	Acceptable	[ACK] [CR]
	Unacceptable	" ? "[CR]

## 7 . Status Read Command

### 7.1. Format

7.1.1. PC issues commands in format as below;

“CR” Command [CR]

Command : 1 character(See Basic Status Read Command Table)

7.1.2. When a projector receives the appropriate command, it returns a character line as the required data.

Required Data [CR]

Required Data : A character line(See Basic Status Read Command Table)

7.1.3. When the received data cannot be decoded, the projector returns “?” [CR].

### 7.2. Transfer Example

Get input mode for projector with basic commands

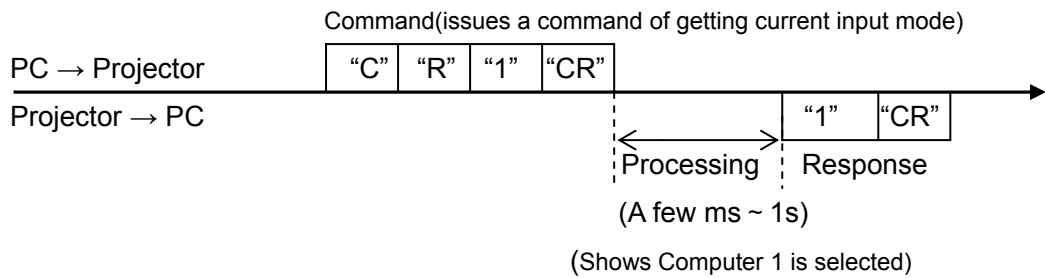

### 7.3. Operation Requirements

When Eco mode is selected in Standby mode of Setting menu and projector is in Standby, Status Read Commands are invalid.

### 7.4. Status Read Command

Command	"CR0" [CR]	
Detail	Get the projector's operating status	
Response	Acceptable	"%1" [CR]
	%1	"00" = Power ON "80" = Standby "40" = Countdown in process "20" = Cooling Down in process "10" = Power Failure "28" = Cooling Down in process due to Temperature Anomaly "88" = Coming back after Temperature Anomaly "24" = Power Save/Cooling Down in process "04" = Power Save "21" = Cooling Down is in process after Power off due to lamp failure "81" = Standby after Cooling Down due to lamp failure
	Unacceptable	"?" [CR]

**[Details of Response]**

**“00” [CR]**

Status : Power ON  
Normal image is on the screen.

**“80” [CR]**

Status: Standby  
When the status is Standby, Status Read Commands are always acceptable, but Functional Execution Commands are not acceptable except POWER ON Command.

**“40” [CR]**

Status: Countdown in process  
When “Display” in Setting Menu is ON and POWER ON is executed, it starts Countdown.  
When “Display” in Setting Menu is OFF, processing Countdown is not executed and the status quickly moves to Power ON.

**“20” [CR]**

Status: Cooling Down in process  
When the status is Power ON, and POWER OFF Command (“C01”[CR]) is executed, it moves to Cooling Down status.  
This status automatically moves to Standby after lamp turns off and the fan spin finishes after about 90 seconds. The fan spin time depends on a model.  
This function is used to cool down the lamps and other optical parts and is quite important for projector’s reliability.  
During this time, Functional Execution Commands are invalid.

**“10” [CR]**

Status: Power Failure  
When the power supply voltage inside the projector reaches abnormal status, the projector is automatically turned off. The projector returns “10”[CR], which shows it moves to Power OFF status due to power failure. Fan also stops unlike Cooling Down status.

**“28” [CR]**

Status: Cooling Down in process due to Temperature Anomaly  
When the inside temperature is out of the operating temperature, it automatically starts Cooling Down. Response for this status is “28”[CR].  
Even if the temperature decreases during this process, Cooling Down is executed.

**“88” [CR]**

Status: Coming back after temperature anomaly  
When the status moves to Standby after Cooling Down due to temperature anomaly, it returns “88” [CR].  
This shows that the status turns to Standby because of abnormal temperature.

This status maintains until next operation is done. When Power On is executed, the information of temperature anomaly is canceled and normal operation is executed.

**“24” [CR]**

Status: Processing Power Save / Cooling Down

Power management function in Setting menu works and the status goes to Power Save / Cooling Down.

During this time, Functional Execution Commands are invalid (not executed).

This status moves to Power Save at set hours after the operation of Cooling Down.

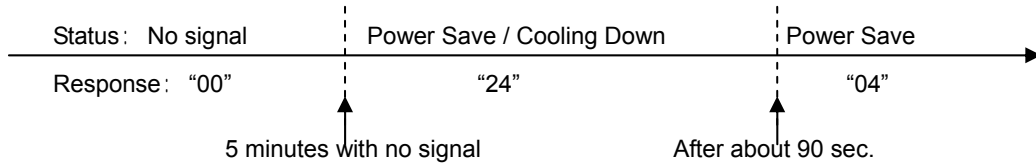

**“04” [CR]**

Status: Power Save

This shows that it moves to Power Save status by Power management function in Setting menu.

**“21” [CR]**

Status: Cooling Down in process after turned off due to lamp failure

When a projector is turned off because of lamp failure, it automatically starts Cooling Down operation, in which the projector returns “21” [CR].

**“81” [CR]**

Status: Standby after Cooling Down due to lamp failure

This value is returned when Cooling Down operation due to lamp failure has been completed and the status has been moved to Standby. The status is kept until the next operation starts.



### 7.5. Input Mode Read Command

Command	"CR1" [CR]	
Detail	Get the selected Input No.	
Response	Acceptable	"%1" [CR]
	%1	"1" = Computer is selected "2" = HDMI is selected "3" = Video is selected LV-7292S/7297S/7292S: "1" = Computer is selected "2" = Video is selected
	Unacceptable	"?" [CR]

### 7.6. Lamp Time Read Command

Command	"CR3" [CR]	
Detail	Get the total lamp running hours (Not actual lamp used hour, but Eco mode corresponding value).	
Response	Acceptable	"%1" [CR]
	%1	Shows the time period with 5 digits numbers. Example: "00410"[CR] ... shows 410 hours
	Unacceptable	"?" [CR]

### 7.7. Setting Read Command

Command	"CR4" [CR]	
Detail	Get screen setting status such as Ceiling / Rear.	
Response	Acceptable	"%1" [CR]
	%1	"11"[CR] = Normal Screen Setting "10"[CR] = Picture is top/bottom reversed. (Status: Rear & Ceiling ON) "01"[CR] = Picture is left/right reversed. (Status: Rear ON) "00"[CR] = Picture is top/bottom and left/right reversed. (Status: Ceiling ON)
	Unacceptable	"?" [CR]

### 7.8. Temp Read Command

Command	"CR6" [CR]	
Detail	Get the temperature data inside the projector. With some temperature sensors installed in the projector, it is possible to get all the temperature at once.	
Response	Acceptable	"%1_%2_%3" [CR]

	%1 %2 %3	<p>%1 = Temperature of sensor 1                  %2 = Temperature of sensor 2                  %3 = Temperature of sensor 3                  Temperature data is shown as "00.0".                  When the temperature goes down to -, the first character becomes "-" instead of a space, like "-05.5" [CR].                  When no temperature data can be returned due to hardware problems, the first character becomes "E" like"E00.0" [CR].                  When several temperature sensors are equipped, Responses are returned continuously.                  "_ 31.5 _ 35.2 _ 33.4"[CR]                  The first data is sensor 1, then one space, and the data of sensor 2 follows.</p>
	Unacceptable	" ? "[CR]

**7.9.Lamp Mode Read Command**

Command	"CR7" [CR]	
Detail	Get lamp mode status. For 1 lamp projector, get if it is lighting or not.	
Response	Acceptable	"%1" [CR]
	%1	"00" [CR]=Light is out. "01" [CR]=Light is on.
	Unacceptable	" ? "[CR]