

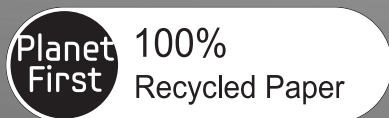

SR8894
SR8895

Robot aspirapolvere Manuale dell'utente



Questo manuale è realizzato interamente con carta riciclata.

- * Prima di utilizzare questo prodotto, leggere attentamente le istruzioni.
- * Solo per uso interno.

Italiano

imagine the possibilities

Grazie per aver acquistato un prodotto Samsung.
Per ricevere un servizio più completo, Registra il
tuo prodotto su
www.samsung.com/register

SAMSUNG

Informazioni sulla sicurezza

INFORMAZIONI SULLA SICUREZZA



- Prima di utilizzare il prodotto, leggere attentamente questo manuale e conservarlo per future consultazioni.



- Dal momento che queste istruzioni coprono diversi modelli del prodotto, le caratteristiche dell'aspirapolvere acquistato potrebbero differire leggermente da quanto descritto in questo manuale.

SIMBOLI DI AVVERTENZA/ATTENZIONE UTILIZZATI



Indica che sussiste il rischio di lesioni gravi perfino mortali.



Indica che sussiste il rischio di lesioni personali o danni materiali.

ALTRI SIMBOLI UTILIZZATI



Spiega i termini utilizzati al fine di facilitare la comprensione da parte dell'utente dell'uso corretto del prodotto.

Informazioni sulla sicurezza

INFORMAZIONI IMPORTANTI SULLA SICUREZZA

Durante l'uso di apparecchiature elettriche, è necessario seguire alcune precauzioni di base, tra le quali:

LEGGERE COMPLETAMENTE LE ISTRUZIONI D'USO PRIMA DI UTILIZZARE IL ROBOT ASPIRAPOLVERE.

Scollegare il prodotto dalla presa di corrente in caso di inutilizzo o prima di effettuare la manutenzione.

ATTENZIONE: per ridurre il rischio di incendio, scariche elettriche o lesioni:

GENERALE

- Usare il prodotto solo secondo quanto descritto in questo manuale.
- Non utilizzare l'aspirapolvere o la base di ricarica qualora presentino danni.
- Se l'aspirapolvere o la base di ricarica ha subito una caduta, danni, è stato lasciato all'esterno, è caduto in acqua o non funziona correttamente, rivolgersi a un centro assistenza.
- Non maneggiare il prodotto o la base di ricarica con le mani bagnate.
- Usare il prodotto solo su superfici asciutte e in interno.
- L'apparecchio non è inteso per l'uso da parte di persone (bambini inclusi) con ridotte capacità fisiche, sensoriali o mentali, inesperte o prive di una adeguata conoscenza, a meno che una persona responsabile per loro sicurezza fornisca loro una corretta supervisione e istruzione all'uso.
- I bambini devono essere controllati per evitare che giochino con l'apparecchio.

BASE DI RICARICA

- Non modificare la spina polarizzata per adattarla a una presa non polarizzata o a un cavo di prolunga.
- Non utilizzare in esterno o su superfici bagnate.
- Scollegare la base di ricarica dalla presa elettrica in caso di inutilizzo e prima di effettuare la manutenzione.
- Usare solo la base di ricarica fornita in dotazione dal costruttore per effettuare la ricarica.
- Non usare se la spina o il cavo di alimentazione sono danneggiati.
- Non trasportare il prodotto tirandolo per il cavo, non utilizzare il cavo come una maniglia, non incastrare il cavo chiudendo una porta, non far passare il cavo intorno a bordi o angoli taglienti. Tenere il cavo lontano da fonti di calore.
- Non utilizzare prolunghe o prese con una capacità di corrente inadeguata al carico.
- Non scollegare la spina di alimentazione tirandola per il cavo. Per scollegare il prodotto, afferrare la spina, non il cavo.
- Non aprire o bruciare le batterie poiché potrebbero esplodere ad elevate temperature.
- Non tentare di aprire la base di ricarica. Eventuali riparazioni devono essere eseguite esclusivamente da un centro di assistenza qualificato.
- Non esporre la base di ricarica a temperature elevate, umidità o vapore.

Informazioni sulla sicurezza

ROBOT ASPIRAPOLVERE

- Non aspirare oggetti rigidi, appuntiti o taglienti come vetro, chiodi, viti, monete o simili.
- Non utilizzare senza filtro. Durante la manutenzione dell'unità, non inserire dita o altri oggetti nel comparto della ventola per evitare lesioni in caso di attivazione accidentale del prodotto.
- Non inserire oggetti estranei nelle aperture di ventilazione. Non utilizzare se le aperture sono ostruite; mantenerle libere da polvere, residui, capelli o qualunque oggetto possa ridurre il flusso dell'aria.
- Non aspirare sostanze tossiche (candeggina, ammoniaca, disgorgante idraulico).
- Non aspirare oggetti in fiamme o che possano causare fumo, quali sigarette, fiammiferi o braci.
- Non utilizzare per aspirare liquidi infiammabili o combustibili quali benzina, né usare in luoghi dove tali sostanze potrebbero essere presenti.
- Non usare il robot aspirapolvere in spazi ristretti in cui siano presenti vapori rilasciati da vernici a base d'olio, diluenti, antitarne, polveri infiammabili, o altri vapori esplosivi o tossici.
- In caso di uso intensivo o temperature estreme, dalle batterie può fuoriuscire liquido. Se il liquido fuoriuscito entra a contatto con la pelle, lavare immediatamente con acqua. Se il liquido fuoriuscito entra a contatto con gli occhi, lavare immediatamente con acqua corrente per almeno 10 minuti. Consultare un medico.

Indice

INFORMAZIONI SULLA SICUREZZA

02

CARATTERISTICHE DEL PRODOTTO

13

MONTAGGIO DELL'ASPIRAPOLVERE

15

FUNZIONAMENTO DELL'ASPIRAPOLVERE

20

MANUTENZIONE STRUMENTI E FILTRO

36

RISOLUZIONE DEI PROBLEMI

43

SPECIFICHE DEL PRODOTTO

46

- 06 Alimentazione
- 07 Prima dell'uso
- 10 Durante l'uso
- 11 Pulizia e manutenzione

- 13 Caratteristiche del prodotto

- 15 Componenti
- 16 Nomenclatura delle parti

- 20 Installazione dell'aspirapolvere
- 20 Installation order
- 20 Accensione e spegnimento
- 21 Installazione della base di ricarica
- 22 Ricarica
- 23 Informazioni sulla batteria
- 24 Impostazione dell'orario
- 25 Installazione della VIRTUAL GUARD
- 27 Inserimento di un panno (opzione)
- 28 Uso del robot aspirapolvere
- 28 Avviare/interrompere la pulizia
- 29 Ricarica
- 30 Pulizia automatica
- 31 Pulizia spot
- 32 Pulizia max
- 33 Pulizia manuale
- 34 Pulizia programmata
- 35 Impostazione della pulizia quotidiana
- 36 Uso delle funzioni aggiuntive (Modalità Turbo, Modalità Ostacoli)

- 36 Pulizia del robot aspirapolvere
- 36 Tenere a mente i metodi di pulizia e manutenzione
- 37 Pulizia della spia del sensore e della telecamera
- 38 Svuotamento rapido della vaschetta di raccolta polvere
- 39 Pulizia della vaschetta di raccolta polvere e del filtro
- 39 Pulizia della spazzola principale
- 41 Pulizia delle spazzole rotative laterali per la pulizia dei bordi
- 42 Pulizia delle ruote di guida
- 42 Cura e manutenzione della spazzol (opzione)
- 43 Checklist prima di chiamare l'assistenza
- 45 Risoluzione dei problemi mediante codici di errore

- 46 Specifiche del prodotto

Informazioni sulla sicurezza

ALIMENTAZIONE



Non piegare eccessivamente il cavo di alimentazione né posizionarvi sopra oggetti pesanti che potrebbero danneggiarlo.

- La mancata osservanza di questa precauzione può causare un incendio o una scarica elettrica.

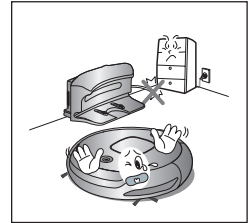

Accertarsi di rimuovere eventuale polvere o acqua dalla spina di alimentazione.

- La mancata osservanza di questa precauzione può causare un malfunzionamento o una scarica elettrica.

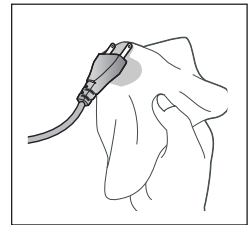

Non estrarre la spina di alimentazione tirandola per il cavo né toccare la spina con le mani bagnate.

- La mancata osservanza di questa precauzione può causare un incendio o una scarica elettrica.

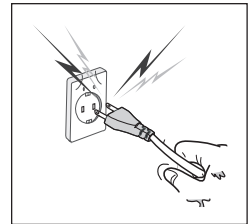

Non usare una spina multipla su una presa singola. (Non lasciare il cavo di alimentazione appoggiato a terra.)

- La mancata osservanza di questa precauzione può causare un incendio o una scarica elettrica.

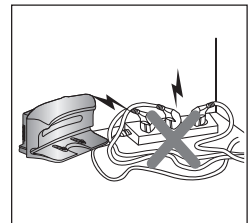

Non usare un cavo o una spina di alimentazione danneggiati o una presa allentata.

- La mancata osservanza di questa precauzione può causare un incendio o una scarica elettrica.

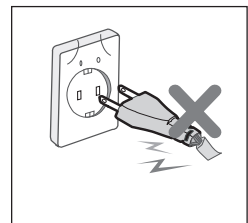

Informazioni sulla sicurezza

PRIMA DELL'USO



Prima di attivare il robot aspirapolvere accertarsi che la vaschetta di raccolta polvere sia inserita.

- Se la vaschetta di raccolta polvere non è inserita, l'aspirapolvere non funziona.

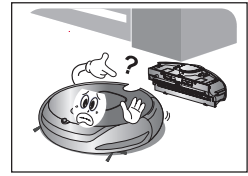

Non usare mai il robot aspirapolvere in luoghi che presentano materiali combustibili quali:

- Candele o lampade da tavolo appoggiate al pavimento.
- Fiamme non sorvegliate (camini o stufe).
- Benzina, alcool distillato, diluenti, portaceneri con sigarette accese, ecc.

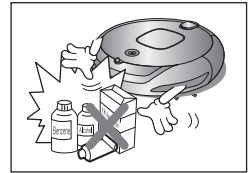

Il robot aspirapolvere è destinato a un uso domestico. Non utilizzare nei seguenti luoghi.

- Attici, interrati, magazzini, edifici industriali, locali separati distanti dall'edificio principale, luoghi esposti all'acqua o all'umidità come bagni o lavanderie, e vicino o sopra tavoli o ripiani.
- Se usato in tali luoghi possono verificarsi seri danni (malfunzionamenti o rotture).



Aprire tutte le porte delle stanze per effettuare la pulizia.

- Quando una porta è chiusa, il robot aspirapolvere non è in grado di accedere alla stanza.
- Tuttavia, verificare che la porta d'ingresso, la porta veranda e quella del bagno siano chiuse, così come eventuali altre porte d'accesso a locali con gradini o altri dislivelli che potrebbero causare la caduta del robot.



In caso di tappeti con lunghe frange, ripiegare le frange sotto il tappeto.

- Se non ripiegate, le frange possono causare danni al tappeto e al robot aspirapolvere, poiché potrebbero rimanere intrappolate nelle ruote di guida o nella spazzola principale.

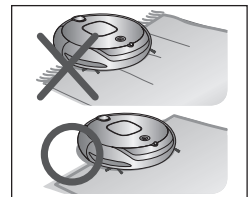

Se il sensore di dislivello è sporco, l'aspirapolvere potrebbe cadere dalle scale d'ingresso, dalla ringhiera, ecc. Ciò potrebbe causare lesioni personali e gravi danni al prodotto. Per evitare tale rischio, installare la VIRTUAL GUARD (impostazione Fence Mode) davanti a zone pericolose. Quindi pulire la spia del sensore e la telecamera per evitare false informazioni.

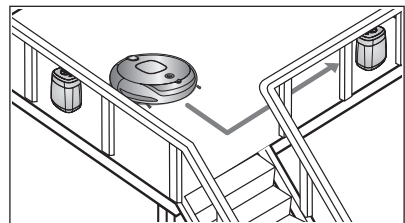

Informazioni sulla sicurezza

PRIMA DELL'USO



Rimuovere eventuali piccoli oggetti od oggetti delicati dall'area da pulire.

- Spostare eventuali oggetti prima di procedere alla pulizia.
- Rimuovere oggetti fragili quali vasi, vetri, porcellane, ecc.
- L'aspirapolvere non è in grado di riconoscere monete, anelli o altri oggetti di valore quali i gioielli.

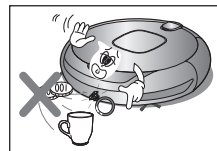

Rimuovere eventuali oggetti sparsi sul pavimento prima di effettuare la pulizia.

- L'aspirapolvere è progettato per rilevare ostacoli a una distanza di 5 cm.
- Eventuali asciugamani, tappetini posti davanti a vasche da bagno, lavandini, ingressi o locali di servizio, cavi di alimentazione, tovaglie e nastri possono rimanere intrappolati nelle ruote di guida o nella spazzola principale. Se nel robot rimane intrappolato un lembo di tovaglia pendente a terra si può verificare la caduta degli oggetti appoggiati sul tavolo.

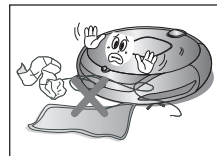

Richiedere ai membri della famiglia (o ai coinquilini) di prestare attenzione prima di effettuare la pulizia o durante l'uso della Modalità di pulizia programmata.

- Il robot aspirapolvere può urtare i bambini, facendoli cadere.



Accertarsi che i bambini non mettano i piedi o si siedano sull'aspirapolvere.

- I bambini potrebbero cadere provocandosi lesioni o danneggiare seriamente il prodotto.



Se un bambino o un animale domestico viene lasciato da solo all'interno della casa, accertarsi che l'interruttore di accensione dell'aspirapolvere sia in posizione off.

- L'aspirapolvere può attrarre la loro attenzione.
- Nelle ruote di guida o nella spazzola potrebbero restare intrappolati dita, piedi, abiti, capelli o peli, provocando lesioni.
- Se un bambino o un animale domestico si trova sulla traiettoria dell'aspirapolvere, potrebbe essere scambiato per un ostacolo e la pulizia della zona potrebbe risultare imperfetta.
- Quando l'interruttore di accensione viene posto in posizione off, l'alimentazione e tutte le funzioni sono disattivate.

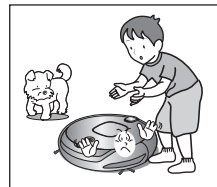

Durante l'installazione della base di ricarica, non lasciare il cavo di alimentazione a terra.

- Quando l'aspirapolvere si dirige verso la base di ricarica o vi passa vicino, potrebbe rimanere impigliato nel cavo.

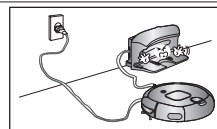

Tenere sempre il cavo di alimentazione della base di ricarica collegato alla presa elettrica.

- Sebbene l'aspirapolvere sia dotato di una funzione di auto ricarica, tale operazione non sarà possibile se il cavo di alimentazione della base di ricarica non è collegato alla presa elettrica.

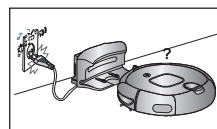

Informazioni sulla sicurezza

PRIMA DELL'USO



Installare la base di ricarica in un luogo facilmente accessibile dal robot aspirapolvere.

- Se la base di ricarica viene posizionata in un angolo, ciò può causare movimenti eccessivi e impedire il regolare processo di ricarica automatica.

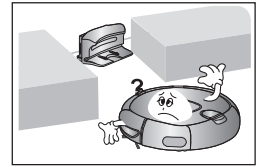

Eventuali oggetti posizionati di fronte alla base di ricarica possono impedire all'aspirapolvere di effettuare autonomamente la ricarica.

- Mantenere la zona sgombra da oggetti.

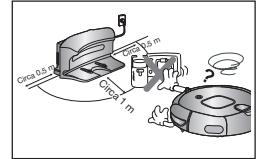

Non devono essere presenti ostacoli entro 0,5 m sulla sinistra e sulla destra ed entro 1 m sul davanti.

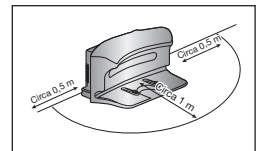

Non provocare un corto circuito dei contatti della base di ricarica con oggetti metallici quali bastoncini, cacciaviti, eccetera.

- In caso contrario potrebbero verificarsi gravi danni alla base di ricarica.

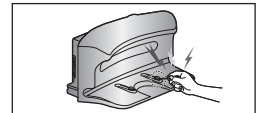

Accertarsi che non vi siano tracce di liquidi sulla base di ricarica.

- La mancata osservanza di questa precauzione può causare un incendio o una scarica elettrica.



Accertarsi che l'aspirapolvere non aspiri o si muova sopra liquidi quali acqua, olio o urina di animali domestici.

- La mancata osservanza di questa precauzione può causare gravi danni al prodotto.
- I liquidi potrebbero spandersi tramite le ruote dell'apparecchio sporcando la zona intorno.

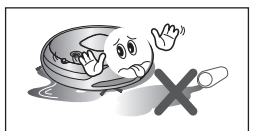

Non utilizzare l'aspirapolvere su pavimenti neri.

- In tal caso, il robot aspirapolvere potrebbe non funzionare correttamente.

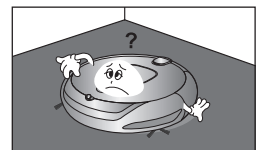

Non utilizzare la base di ricarica per scopi diversi da quelli previsti dal costruttore.

- La mancata osservanza di questa precauzione può causare gravi danni alla base di ricarica o provocare un incendio.

Informazioni sulla sicurezza

DURANTE L'USO



L'aspirapolvere non è idoneo per la pulizia di tappeti molto spessi.

- La mancata osservanza di questa indicazione può causare problemi durante l'uso del robot aspirapolvere.
- E' possibile arrecare danni al tappeto.

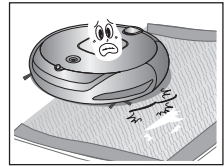

Non usare l'aspirapolvere su un tavolo o in luoghi elevati da terra.

- La caduta accidentale può causare danni all'unità.



Durante il suo funzionamento l'aspirapolvere può urtare contro l'arredamento, per esempio le gambe delle sedie, dei tavoli, pezzi di arredamento lunghi e sottili, ecc..

- Per accelerare e ottimizzare il processo di pulizia, sollevare le sedie da terra posizionandole sopra i tavoli.

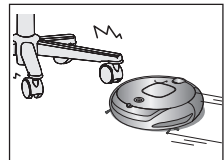

Non collocare oggetti sopra l'aspirapolvere.

- In caso contrario si potrebbe verificare un malfunzionamento.



Rimuovere immediatamente eventuali pezzi di carta o di plastica di grandi dimensioni aspirati dal robot durante la pulizia.

- L'uso dell'aspirapolvere per un lungo periodo di tempo con i fori di ventilazione ostruiti può comportare gravi danni al prodotto.

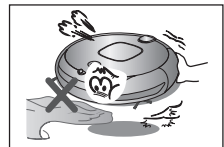

Se si avverte un rumore insolito, fumo od odore di bruciato proveniente dall'aspirapolvere, spegnere immediatamente l'apparecchio e chiamare il centro assistenza.

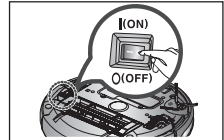

Il robot aspirapolvere potrebbe non essere in grado di svolgere la sua funzione se bloccato sulle scale di ingresso o sulla veranda.

- Per motivi di sicurezza, il robot aspirapolvere interrompe il funzionamento se non è in grado di muoversi per più di 5 minuti.
- Per riprendere il regolare funzionamento, spegnerlo e riaccenderlo dopo averlo spostato in una nuova posizione nella quale sia in grado di proseguire la sua funzione.

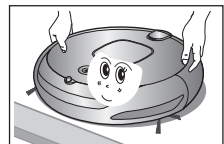

Informazioni sulla sicurezza

DURANTE L'USO



NOTA

Il robot aspirapolvere non è in grado di pulire completamente le aree che non è in grado di raggiungere, come per esempio gli angoli e gli spazi tra divani e pareti.

- Pulire di tanto in tanto queste zone manualmente.

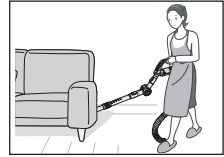

NOTA

Se il robot aspirapolvere forma tracce di polvere, è possibile che queste rimangano non pulite.

- In questo caso, raccogliere la polvere utilizzando uno strumento diverso.



AVVERTENZA

Con il panno per la pulizia inserito, il robot non riesce a spostarsi sui tappeti. (opzione)

- Per la pulizia dei tappeti, togliere il panno e la relativa piastra di fissaggio.

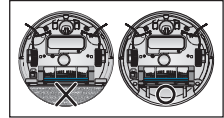

AVVERTENZA

Non utilizzare questo prodotto con un panno umido o bagnato. (opzione)



PULIZIA E MANUTENZIONE



AVVERTENZA

Durante la pulizia del prodotto, non spruzzarvi sopra acqua né pulirlo con sostanze volatili quali benzina, diluenti o alcool.

- La mancata osservanza di questa precauzione può causare gravi danni al prodotto.



AVVERTENZA

Non premere con forza il paracolpi del robot aspirapolvere.

- In caso di danneggiamento del sensore paracolpi, il robot aspirapolvere può urtare pareti e mobili.

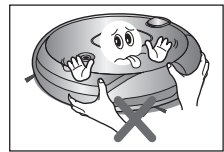

AVVERTENZA

L'unità deve essere disassemblata o riassembleta solo da tecnici dell'assistenza qualificati.

- La mancata osservanza di questa precauzione può causare danni al prodotto.



Informazioni sulla sicurezza

PULIZIA E MANUTENZIONE



ATTENZIONE

Rimuovere regolarmente eventuali corpi estranei accumulatisi davanti ai sensori Ostacoli e Dislivello.

- Lo sporco che si accumula sui sensori può comportare un funzionamento inaccurato dei sensori.

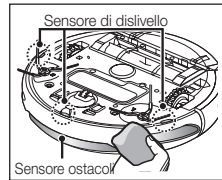

ATTENZIONE

Durante la rimozione di corpi estranei, spegnere l'apparecchio prima di verificare la spazzola di pulizia.

- La mancata osservanza di questa precauzione può comportare l'accensione accidentale dell'unità e causare lesioni personali o gravi danni al prodotto.

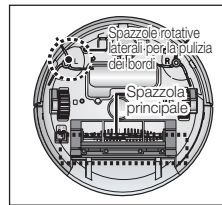

ATTENZIONE

Se il cavo di alimentazione è danneggiato, richiederne la sostituzione a un tecnico qualificato presso un centro assistenza.

- La mancata osservanza di questa precauzione può causare un incendio o una scarica elettrica.



ATTENZIONE

Prima di pulire la base di ricarica, scollegare il cavo di alimentazione.



ATTENZIONE

Al termine della pulizia, lavare e asciugare completamente il panno prima di riutilizzarlo. (opzione)

- In caso contrario, il panno potrebbe emanare cattivi odori.

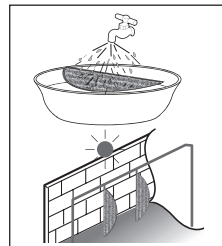

ATTENZIONE

Per effettuare la sostituzione della batteria, contattare un centro di assistenza Samsung Electronics.

- L'uso di batterie non originali può comportare un malfunzionamento del prodotto.

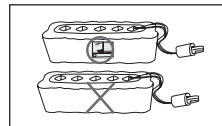

Caratteristiche del prodotto

COMODA FUNZIONE VIRTUAL GUARD

E' possibile restringere il raggio d'azione del robot aspirapolvere a una zona delimitata usando la modalit  Fence (recinto virtuale) o effettuando la pulizia di pi  zone una alla volta utilizzando la modalit  Guard (porta virtuale).



• Cosa significa riconoscimento della forma del soffitto (Visionary mapping™)?

Questa funzione riconosce la forma del soffitto mediante una telecamera posizionata sulla parte superiore dell'apparecchio per identificare l'area da pulire e il modo migliore per passarvi sopra e pulire ogni sezione del pavimento.

PULIZIA DELICATA DI OGNI ANGOLO

Poich  il robot aspirapolvere   in grado di pulire il pavimento in modo sequenziale ( ) seguendo una mappa determinata dalla funzione di riconoscimento della forma del soffitto,   in grado di pulire anche ogni angolo del pavimento.

VARIE MODALITA' DI PULIZIA

Per soddisfare tutte le esigenze di pulizia sono disponibili varie modalit  di funzionamento.

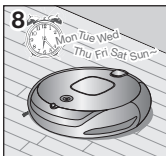
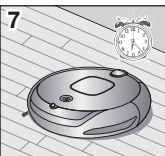
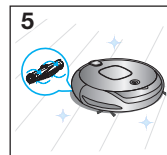
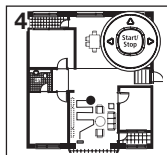
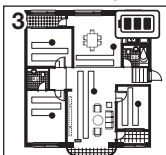
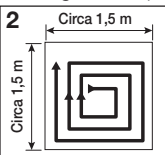
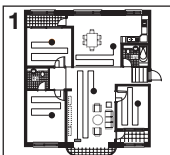

1. Modalit  Auto : Pulisce tutte le stanze in modo automatico.

2. Modalit  Spot : Pulisce in modo accurato una zona delimitata. Questa modalit  pu  essere utilizzata per pulire briciole di pane o di torta.

3. Modalit  Max : Continua ad effettuare la pulizia fino a quando la batteria   quasi scarica.

4. Modalit  Manuale : E' possibile utilizzare il robot manualmente mediante telecomando per pulire la superficie desiderata.

5. Modalit  Turbo : In questa modalit , la spazzola principale ruota alla velocit  massima consentendo una pulizia pi  efficace.
(E' inoltre possibile cambiare modalit  usando il telecomando.)

6. Modalit  Bordi : Quando il Sensore ostacoli rileva un ostacolo durante la pulizia, il robot riduce la velocit  per attenuare l'impatto e il Sensore paracolpi consente a sua volta di attutire ulteriormente l'urto. Inoltre, il robot riesce ad effettuare una pulizia accurata avvicinandosi il pi  possibile a bordi e angoli.

7. Modalit  di pulizia programmata : All'ora impostata, il robot aspirapolvere inizia la pulizia del pavimento.

8. Modalit  Pulizia quotidiana : Il robot aspirapolvere pulisce il pavimento ogni giorno all'orario specificato.

BOCCHETTA DI USCITA POLVERE

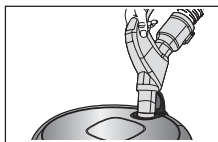

La pratica bocchetta di uscita polvere posta sulla parte superiore del robot consente di svuotare facilmente la vaschetta di raccolta utilizzando un normale aspirapolvere, evitando cos  qualsiasi fuoriuscita.

Caratteristiche del prodotto

AUTO RICARICA

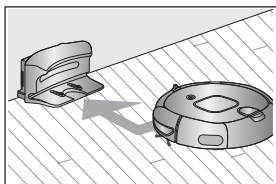

Quando il livello di carica della batteria è basso, il robot aspirapolvere si dirige automaticamente verso la base di ricarica per effettuare una ricarica rapida.

SPAZZOLE ROTATIVE LATERALI PER LA PULIZIA DEI BORDI

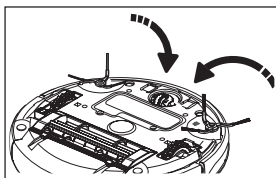

Le spazzole rotative laterali per la pulizia dei bordi eseguono la pulizia dei punti più inaccessibili.

ATTRAVERSAMENTO DEI DISLIVELLI

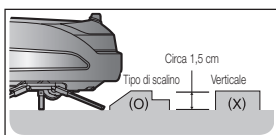

L'innovativo sistema di guida dell'aspirapolvere permette al robot di superare eventuali dislivelli tra le soglie con altezza massima di 1,5 cm. A seconda della forma della soglia, il robot aspirapolvere potrebbe non essere in grado di oltrepassare un dislivello di 1,5 cm.

ANTI URTO

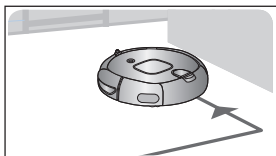

Il robot aspirapolvere rileva ed evita eventuali ostacoli in due fasi. La fase 1 consiste nella rilevazione, da parte del sensore 8 ostacoli, di eventuali ostacoli lungo il percorso del robot in modo da evitare l'impatto; la fase 2 prevede l'assorbimento dell'urto da parte del sensore paracolpi.

ANTI CADUTA

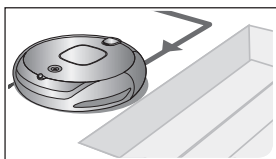

Per impedire la caduta del robot aspirapolvere, i 3 sensori di dislivello rilevano la presenza di eventuali vuoti sulla superficie del pavimento, come scalini o soglie d'ingresso.

DISPOSITIVO DI SICUREZZA

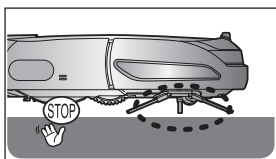

Se durante il funzionamento il robot aspirapolvere viene sollevato da terra, le ruote di guida, la spazzola principale, il motore di aspirazione, le spazzole rotative laterali vengono automaticamente fermate da un sensore di rilevamento.

Montaggio dell'aspirapolvere

COMPONENTI



■ Corpo principale

■ Telecomando

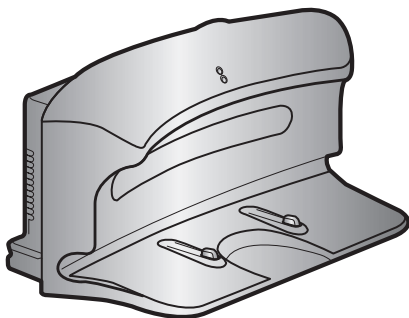

■ Base di ricarica (Stazione)

■ Altri componenti

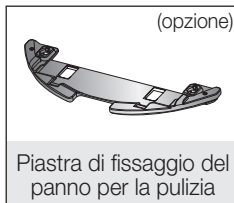
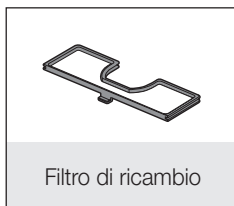
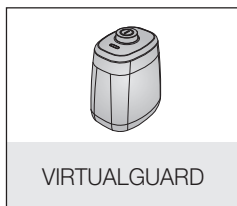

Montaggio dell'aspirapolvere

NOMENCLATURA DELLE PARTI

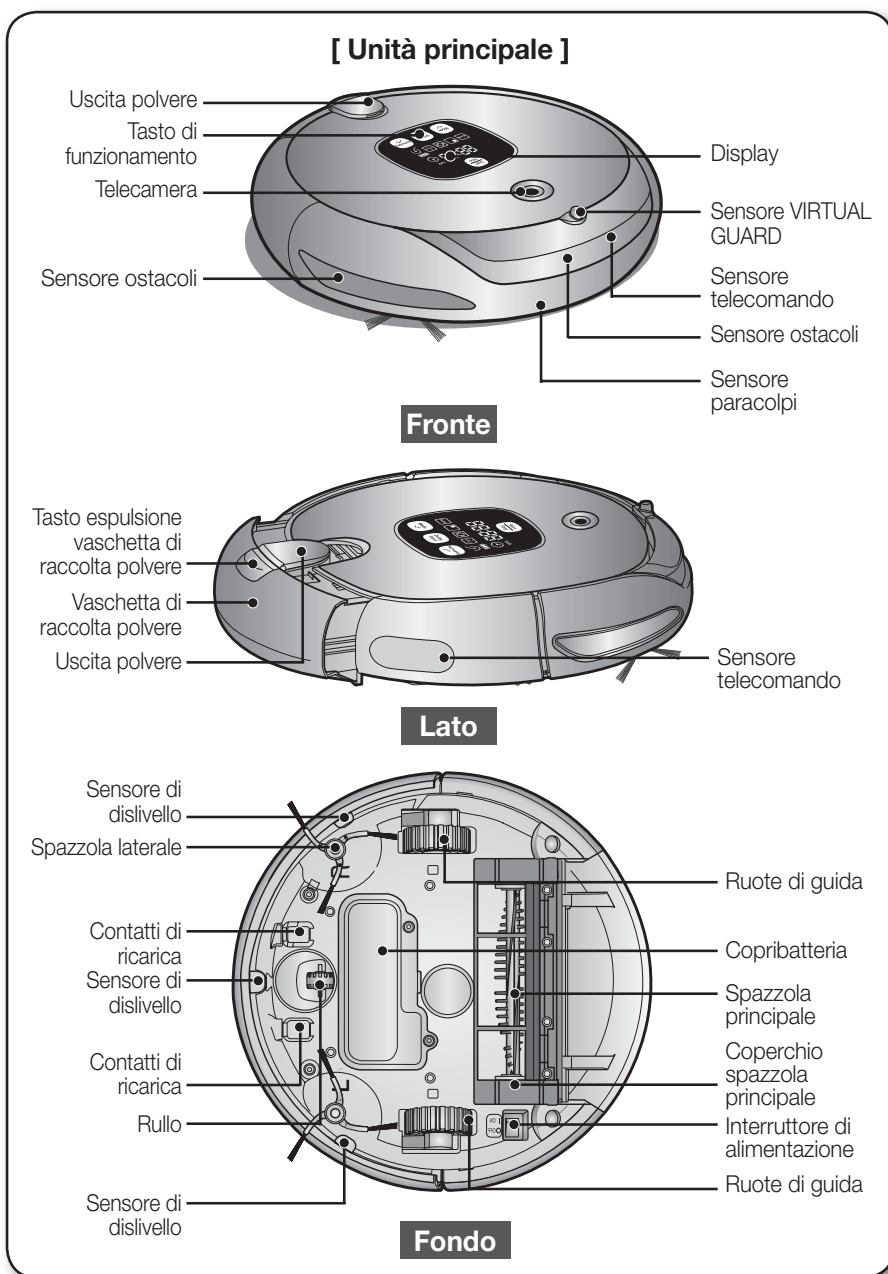

Montaggio dell'aspirapolvere

NOMENCLATURA DELLE PARTI

[Base di ricarica (Stazione)]

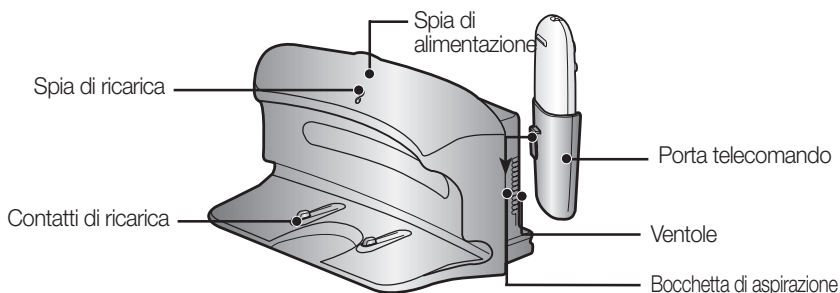

[VIRTUAL GUARD]

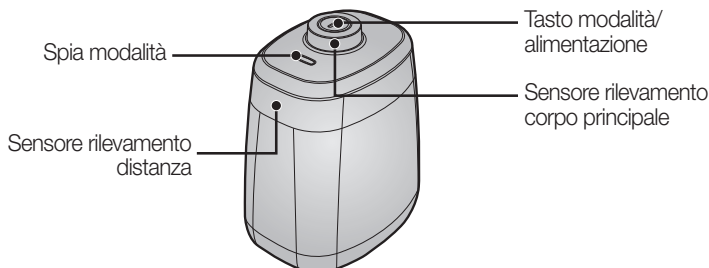

■ Installazione delle batterie

Le batterie non sono fornite in dotazione. Sono acquistabili separatamente. Prima di utilizzare il prodotto installare le batterie alcaline (tipo D).



* Specifiche: Batterie alcaline tipo D (LR20)

Montaggio dell'aspirapolvere

NOMENCLATURA DELLE PARTI

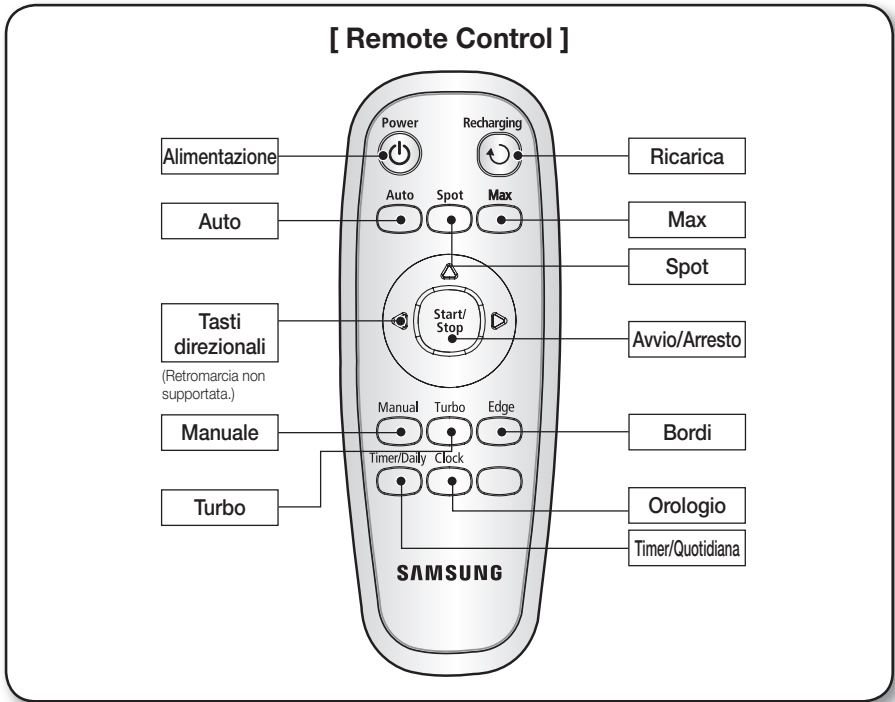

■ Inserimento delle batterie nel telecomando

Le batterie non sono montate nel telecomando al momento dell'acquisto dell'unità. Prima di utilizzare il prodotto inserire le batterie alcaline (tipo AAA).



* Specifiche: Batterie alcaline tipo AAA

Montaggio dell'aspirapolvere

NOMENCLATURA DELLE PARTI

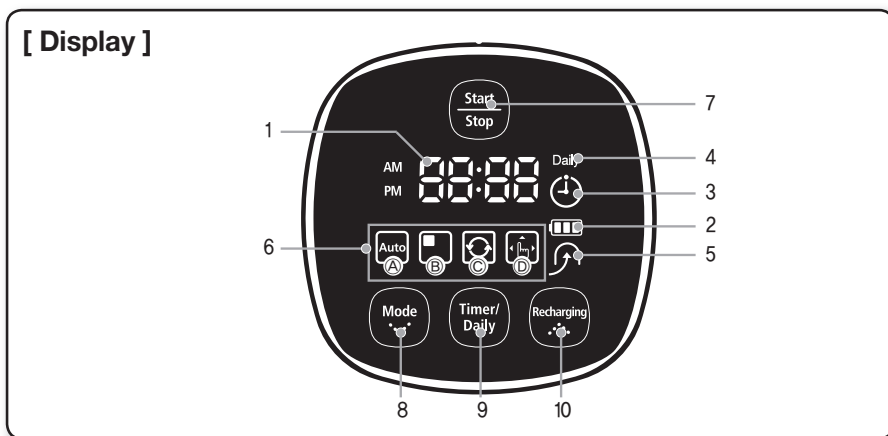

PARTI DEL DISPLAY

1. Numero

- Mostra il timer, lo stato del progresso e i codici di errore mediante numeri, lettere e simboli grafici.

2. Indicatore livello batteria

- Ricarica: Mostra l'andamento della ricarica in tre fasi.

- In Uso: Mostra il livello di carica della batteria. Il livello di carica della batteria scende da FULL a ogni livello indicato durante l'uso. (Quando la batteria è completamente scarica, un livello lampeggerà visualizzando "LO".)

3. Pulizia programmata

- Quando è impostata la pulizia programmata, l'icona Pulizia programmata è accesa.

4. Quotidiana

- Quando è impostata la pulizia quotidiana, l'icona Quotidiana è accesa.

5 Ricarica

- Questa icona si attiva quando il robot aspirapolvere torna alla base di ricarica per ricaricare le batterie.

6. Visualizzazione della modalità di pulizia

- Ogni qualvolta il tasto della modalità di pulizia viene premuto, viene visualizzata la modalità di pulizia corrispondente.

(a) Modalità Auto: Questa icona si attiva quando la modalità di pulizia Auto è selezionata.

(b) Modalità Spot: Questa icona si attiva quando la modalità di pulizia Spot è selezionata.

(c) Modalità Max: Questa icona si attiva quando la modalità di pulizia Max è selezionata.

(d) Modalità Manuale: Questa icona si attiva quando la modalità di pulizia Manuale è selezionata.

TASTI

7. Avvio/Arresto

- Premere per avviare/terminare la pulizia.

8. Modalità di pulizia

- Premere per selezionare una modalità di pulizia. Una volta selezionata una modalità di pulizia, premere il tasto (Start/Stop) per avviare la pulizia.

9. Timer/Quotidiana

- Premere per programmare la pulizia

10. Ricarica

- Premendo questo tasto, l'icona Ricarica si accende e il robot aspirapolvere torna alla base di ricarica per effettuare la ricarica delle batterie in esaurimento.

Funzionamento dell'aspirapolvere

INSTALLAZIONE DEL ROBOT ASPIRAPOLVERE

ORDINE DI INSTALLAZIONE

1. Accensione e spegnimento

Per utilizzare il robot aspirapolvere, è necessario accendere l'unità agendo sull'apposito tasto posto sul fondo dell'apparecchio.

2. Installazione della base di ricarica

Per effettuare la ricarica delle batterie del robot aspirapolvere è necessario installare la base di ricarica.

Poiché le batterie sono scariche al momento dell'acquisto, prima di utilizzare l'unità è necessario effettuare una carica completa.

3. Ricarica delle batterie

Prima di utilizzare il robot aspirapolvere è necessario caricare completamente le batterie.

4. Impostazione dell'orario

E' possibile impostare l'orario da utilizzare per le operazioni di pulizia programmata e quotidiana.

5. Installazione della VIRTUAL GUARD

E' possibile restringere il raggio d'azione del robot aspirapolvere a una zona delimitata usando la modalità Fence (recinto virtuale) o effettuando la pulizia di più zone una alla volta utilizzando la modalità Guard (porta virtuale).

6. Inserimento di un PANNO

Fissare il panno al fondo del robot.



ACCENSIONE E SPEGNIMENTO

Per utilizzare il robot aspirapolvere è necessario accenderlo.

Spegnendo il prodotto, tutte le sue impostazioni verranno ripristinate allo stato iniziale.

1. Girare l'unità per accenderla.

- Se le icone non si illuminano, ciò indica che la carica delle batterie si è esaurita. In questo caso, inserire il robot nella base di ricarica dopo averlo acceso.

- Notare che lo spegnimento dell'unità provocherà il ripristino di tutte le impostazioni allo stato iniziale.

* Se dall'accensione del prodotto non viene premuto alcun tasto per 5 minuti, il prodotto si spegne automaticamente per preservare la batteria. Per

riaccendere il prodotto, tenere premuto per un istante il tasto (Run/Stop) (Avvia/Arresta) sull'unità o sul telecomando.

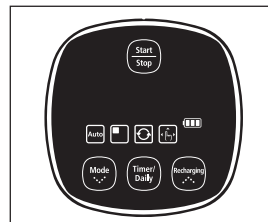
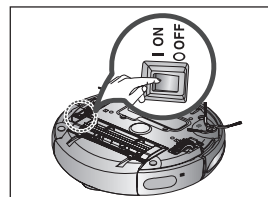

Inserendo il robot spento nella base di ricarica, la ricarica delle batterie non avverrà.

Funzionamento dell'aspirapolvere

INSTALLAZIONE DEL ROBOT ASPIRAPOLVERE

INSTALLAZIONE DELLA BASE DI RICARICA

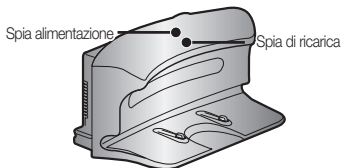

1. Installare la base di ricarica su una superficie piana.

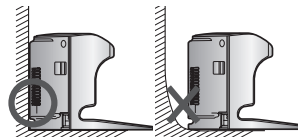

2. Non devono essere presenti ostacoli entro 0,5 m sulla sinistra e sulla destra ed entro 1 m sul davanti.

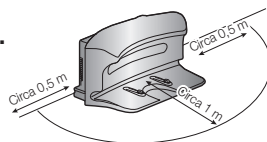

3. Installare la base di ricarica in un luogo facilmente accessibile dal robot aspirapolvere.



4. Posizionare il cavo di alimentazione lungo la parete.

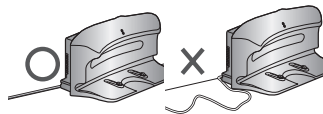

5. Se il pavimento è in legno, installare la base di ricarica nella stessa direzione dei listelli in legno.

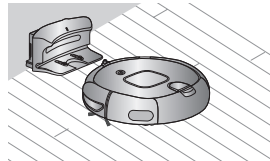

NOTA

Mantenere sempre il cavo di alimentazione della base di ricarica collegato alla presa elettrica.

- Se la base di ricarica non è collegata a una presa elettrica, il robot aspirapolvere non è in grado di trovare la base per ricaricare automaticamente le batterie.
- Se il robot aspirapolvere viene tenuto separato dalla base di ricarica, la batteria inizia a scaricarsi.

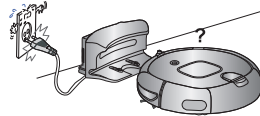

Funzionamento dell'aspirapolvere

INSTALLAZIONE DEL ROBOT ASPIRAPOLVERE

RICARICA

Al momento dell'acquisto del prodotto, la batteria è completamente scarica ed è necessario caricarla completamente prima dell'utilizzo.

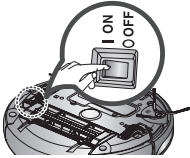
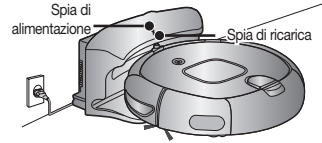

Accendere il prodotto premendo l'interruttore posto sul fondo.

- 1. Una volta allineati i contatti di ricarica del corpo principale dell'unità con i contatti presenti sulla base di ricarica, premere il prodotto fino ad avvertire l'avviso di "ricarica in corso" proveniente dalla base.**

- La spia di ricarica diventa verde.

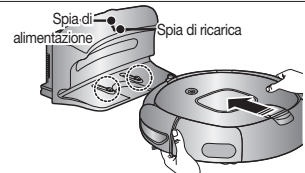

- 2. Verificare lo stato della ricarica del robot aspirapolvere.**

- All'inizio della ricarica, sul pannello del display verranno visualizzati in sequenza il livello di carica della batteria e "B".
- Al termine del ciclo di ricarica, sul pannello del display verranno visualizzati in sequenza il livello di carica della batteria e "FULL".



Ricarica in corso Ricarica completa

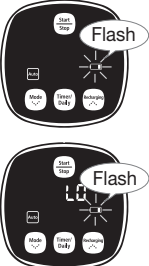

- Quando sul display il livello della batteria lampeggia durante la pulizia, il robot aspirapolvere interrompe le sue operazioni per dirigersi automaticamente alla base di ricarica per effettuare la carica delle batterie.
- Quando il display lampeggia con il simbolo "LO" durante la pulizia, il robot aspirapolvere non può essere gestito mediante il telecomando o i tasti posti sul corpo principale dell'unità. In questo caso, portare manualmente il robot alla stazione di ricarica e collegarlo. (Ciò avviene quando la batteria è completamente scarica.)

<display di ricarica>



Carica completa Ricarica in corso Ricarica necessaria

NOTA

- Al momento dell'acquisto iniziale del prodotto, sono necessari circa 120 minuti per effettuare una ricarica completa della batteria per avere una autonomia di funzionamento di circa 90 minuti.
- Se la ricarica viene effettuata quando la batteria è surriscaldata, il tempo necessario per la ricarica può risultare maggiore.
- Misure da intraprendere quando la ricarica non viene effettuata in modo regolare. Se il robot aspirapolvere non può essere ricaricato automaticamente in modo regolare, verificare le seguenti condizioni:
 - Spegnerne e riaccendere l'unità agendo sul tasto posto sul fondo del prodotto (Reset).
 - Ricollegare l'aspirapolvere alla base di ricarica (Reset).
 - Verificare che non vi siano corpi estranei sul connettore della base di ricarica e pulire il connettore posto sull'unità e quello della base di ricarica con un panno asciutto.
 - Verificare che non vi siano oggetti vicino alla base di ricarica che possano riflettere il segnale.
- Quando il robot aspirapolvere viene separato dalla base di ricarica, le batterie iniziano a scaricarsi naturalmente.
 - Se possibile procedere alla ricarica delle batterie mediante la base di ricarica. (In caso di assenza prolungata per un viaggio di lavoro o una vacanza, spegnere il robot aspirapolvere e scollegare la spina del cavo di alimentazione della base di ricarica.)

Funzionamento dell'aspirapolvere

INSTALLAZIONE DEL ROBOT ASPIRAPOLVERE

INFORMAZIONI SULLA BATTERIA

- Il robot aspirapolvere è alimentato da una batteria ricaricabile nichel-metallo idruro (NiMH) ed è dotato di una protezione per la sovraccarica al fine di garantirne una lunga durata.
- **Il periodo di garanzia della batteria è di 6 mesi dalla data di acquisto.**
- Prima di acquistare una nuova batteria, fornire al centro di assistenza il nome del modello della batteria e richiedere il ricambio originale recante il simbolo .

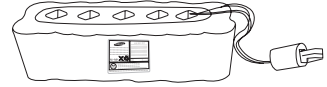

- Questa batteria è studiata solo per l'uso con robot aspirapolvere Samsung. E' proibito l'uso con altri apparecchi o per altri scopi.
- Non disassemblare o modificare la batteria.
- Ricaricarla in un luogo ben ventilato.
- Non collocare la batteria su un fuoco o una sorgente di calore.
- Non appoggiare oggetti metallici sui poli (+) o (-) della batteria.
- Tenere il prodotto all'interno (0°C~40°C).
- Prima di smaltire questo prodotto, smaltire le batterie in modo responsabile.
- Non smaltire le batterie insieme ai normali rifiuti domestici.
- Seguire tutte le normative locali per lo smaltimento delle batterie esauste.

- * Se le batterie non sono regolarmente funzionanti, non disassemblarle. Contattare il più vicino Centro di assistenza.
- * Un maggiore tempo di ricarica e una minore durata della batteria indica l'approssimarsi della fine del ciclo di vita della batteria. Contattare un Centro di assistenza autorizzato per richiedere un batteria sostitutiva.

La batteria ricaricabile incorporata nel prodotto non è sostituibile dall'utente. Per informazioni sulla sostituzione, rivolgersi al fornitore del servizio.

Funzionamento dell'aspirapolvere









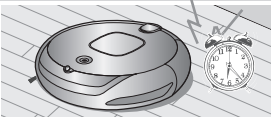

INSTALLAZIONE DEL ROBOT ASPIRAPOLVERE

IMPOSTAZIONE DELL'ORARIO

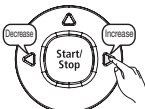
Per utilizzare le funzioni Pulizia programmata e Pulizia quotidiana, impostare l'orario come desiderato.

E' possibile impostare l'orario solo mediante telecomando.

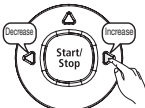
■ E' possibile impostare l'orario solo mediante telecomando.

	Telecomando	Sequenza configurazione
 <p>Supponendo che l'orario attuale sia le 07:00 del mattino.</p>  <p>a.m. 88</p>	 <p>Clock</p>	1 Immettere "ora" corrente.
 <p>a.m. 7</p>		2 Immettere modalità di impostazione.
 <p>a.m. 7:88</p>	 <p>Clock</p>	3 Impostare "ora".
 <p>a.m. 7:00</p>		4 Immettere "minuti" correnti.
 <p>a.m. 7:00</p>	 <p>Clock</p>	5 Terminare l'impostazione.

- Durante l'impostazione dell'ora, premere (Start/Stop) al posto del tasto Impostazione orario e uscire dalla modalità Impostazione orario.
- Quando è impostata la modalità Pulizia programmata, non è possibile modificare l'impostazione dell'ora.

Funzionamento dell'aspirapolvere

INSTALLAZIONE DEL ROBOT ASPIRAPOLVERE

INSTALLAZIONE DELLA VIRTUAL GUARD

E' possibile restringere il raggio d'azione del robot aspirapolvere a una zona delimitata usando la modalità Fence (recinto virtuale) o effettuando la pulizia di più zone una alla volta utilizzando la modalità Guard (porta virtuale).

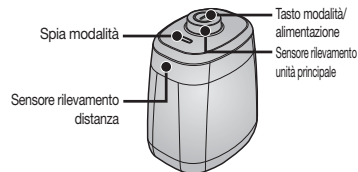

Funzioni dei tasti

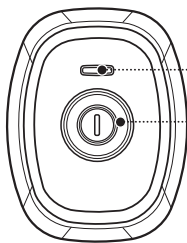

1. Funzioni della spia Modalità

- Modalità Fence (barriera virtuale): La spia rossa lampeggia.
- Modalità Guard (porta virtuale): La spia verde lampeggia.
- Off: La spia è spenta.

2. Impostazione della modalità

- Premendo il tasto Modalità/Alimentazione verranno attivate in sequenza le seguenti modalità, Fence (barriera virtuale) → Guard (porta virtuale) → Off (spegnimento).

* La distanza della parete virtuale è di 2,5 m come minimo e può essere differente in funzione e degli ambienti e dello stato di movimento del robot.

Formazione di una barriera (parete virtuale)

VIRTUAL GUARD crea un barriera invisibile che il robot aspirapolvere non è in grado di superare. Per es. di fronte a vasi, mobili, porte d'ingresso e così via.

1. Selezionare la modalità (parete virtuale) usando il tasto Modalità/Alimentazione.

- La spia della modalità lampeggia in rosso.

2. Installare la VIRTUAL GUARD di fronte all'area per la quale si desidera bloccare l'accesso al robot aspirapolvere.

- Installare la VIRTUAL GUARD in modo che il sensore di rilevamento della distanza formi una barriera invisibile che il robot aspirapolvere non è in grado di superare.

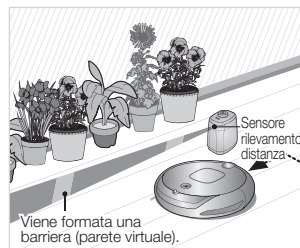

Funzionamento dell'aspirapolvere

Uso della modalità Guard (porta virtuale)

VIRTUAL GUARD forma una porta invisibile che il robot aspirapolvere non è in grado di superare fino alla completa pulizia della stanza. VIRTUAL GUARD apre la porta invisibile solo una volta terminate la pulizia della stanza.

1. Selezionare la modalità Guard (porta virtuale) usando il tasto Modalità/Accensione.

- La spia della modalità lampeggia in verde.

2. Installare VIRTUAL GUARD all'ingresso della stanza da pulire.

- Installare la VIRTUAL GUARD in modo che il sensore di rilevamento della distanza formi una barriera invisibile che il robot aspirapolvere non è in grado di superare.

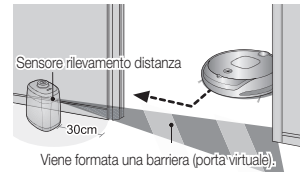
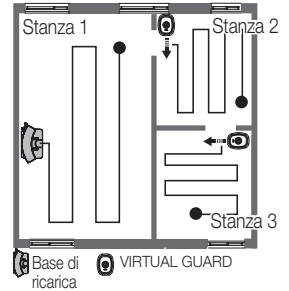

- In caso di non utilizzo della modalità VIRTUAL GUARD, disattivarla.
(In caso di inutilizzo prolungato del robot aspirapolvere, estrarre le batterie per evitare che si scarichino.)
- Se il tasto Modalità/Alimentazione non funziona, ciò indica che le batterie sono scariche. In questo caso, sostituirle. (Specifiche: batterie alcaline tipo D (LR20))
- E' possibile acquistare una ulteriore VIRTUAL GUARD presso un Rivenditore autorizzato Samsung Electronics.

* Poiché viene formata una barriera invisibile per impedire al robot aspirapolvere di urtare la VIRTUAL GUARD, si consiglia di installare la VIRTUAL GUARD entro 30 cm dalle pareti esterne.



Informazioni sul sensore IrDA.

- La trasmissione a infrarossi potrebbe essere irregolare nei luoghi esposti a luce alogena o in spazi aperti.
- Il robot aspirapolvere utilizza 3 tipi di dispositivi a infrarossi, dei quali uno potrebbe non funzionare regolarmente davanti a un altro dispositivo con priorità superiore.
- Durante il controllo del robot aspirapolvere mediante telecomando, il robot potrebbe attraversare la barriera virtuale del VIRTUAL GUARD o urtare un ostacolo il cui segnale abbia una priorità maggiore rispetto a quello della VIRTUAL GUARD.
- In caso di uso del robot in un ambiente ristretto o a una distanza ridotta, l'unità potrebbe non funzionare regolarmente a causa delle interferenze dei segnali a infrarossi.
- Installare la VIRTUAL GUARD lontano dalla base di ricarica poiché, se troppo vicina, potrebbe interrompere le operazioni di ricarica automatica.
- In caso di utilizzo simultaneo di più robot aspirapolvere, il loro funzionamento potrebbe risultare irregolare a causa delle interferenze dei segnali a infrarossi.



Funzionamento dell'aspirapolvere

USO DEL ROBOT ASPIRAPOLVERE

INSERIMENTO DI UN PANNO (OPZIONE)

Il panno in microfibre consente di rimuovere la polvere in modo più efficace.

Istruzioni per l'inserimento del panno

1. Fissare il panno al velcro sulla piastra di fissaggio.

- Fissare il panno verificando che la linea di fissaggio non sia coperta.

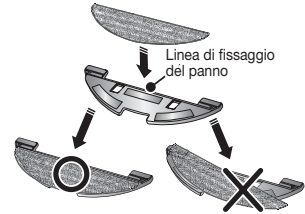

- * Fissare il panno in modo che sia parallelo alla linea di fissaggio.

2. Allineare i fori della piastra di fissaggio agli elementi corrispondenti sul fondo del robot, quindi premere gli elementi in posizione finché si avverte il 'clic' che segnala il corretto inserimento.

- E' importante notare che se la piastra non è correttamente inserita potrebbe separarsi dal robot durante la pulizia.

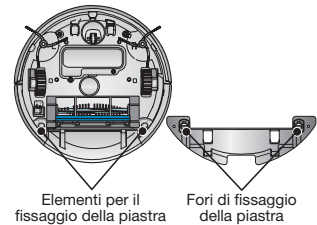

3. Collocare la piastra di fissaggio del panno sul pavimento e premere verso il basso.



- Poiché il robot non riesce a muoversi sui tappeti se il panno è inserito, rimuovere sia il panno sia la piastra di fissaggio prima di eseguirne la pulizia.
- Al termine della pulizia, lavare il panno sporco.
- Far asciugare completamente il panno prima di riutilizzarlo. (Non utilizzare panni umidi o bagnati.)
- In presenza di superfici bagnate, per esempio se è caduto del caffè sul pavimento, non utilizzare il panno per asciugare la macchia per evitare di sporcare il resto del pavimento con il panno sporco.

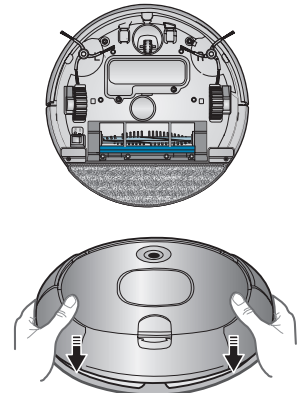

Funzionamento dell'aspirapolvere

USO DEL ROBOT ASPIRAPOLVERE

AVVIARE/INTERROMPERE LA PULIZIA

E' possibile attivare o disattivare tutte le funzioni del robot aspirapolvere.

- Ogni funzione viene eseguita solo se l'interruttore di accensione è in posizione On.
- Quando il robot aspirapolvere è in funzione, premere il tasto (Start/Stop) per annullare l'operazione e selezionare una funzione.

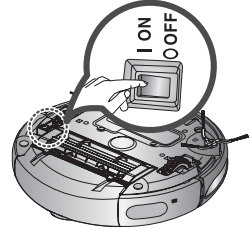

Accensione e spegnimento

Accensione

- Telecomando: Premere il tasto **[Power]**.
- Unità principale: Premere il tasto (Start/Stop).

Spegnimento

- Telecomando: Premere il tasto **[Power]**.
- Unità principale: Tenere premuto il tasto (Start/Stop) per 3 secondi.

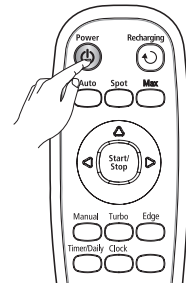

Uso del telecomando

Avviare/interrompere la pulizia

Avviare

- Telecomando: Premere il tasto Auto, Spot, Max, Manuale.
- Unità principale: Selezionare la modalità Auto / Spot / Max / Manuale / premendo il tasto (Mode) quindi premere (Start/Stop).
- All'inizio del ciclo di pulizia, il robot aspirapolvere inizia a muoversi.
- * La pressione del tasto (Start/Stop) senza la selezione di una modalità di pulizia attiva la modalità di pulizia Auto.

Interrompere

- Per arrestare le operazioni del robot, premere il tasto (Start/Stop) sul telecomando o il tasto sull'unità principale.
- Quando le operazioni di pulizia vengono interrotte, il robot aspirapolvere si ferma.

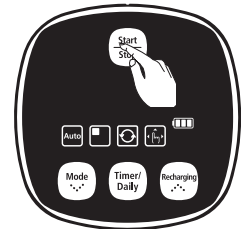

Uso dei tasti dell'unità principale

Funzionamento dell'aspirapolvere

USO DEL ROBOT ASPIRAPOLVERE

RICARICA

Premendo il tasto Ricarica, il robot aspirapolvere torna alla base di ricarica per effettuare la ricarica delle batterie.

- Quando il robot aspirapolvere è in funzione, premere il tasto  per annullare l'operazione e premere il tasto Ricarica.

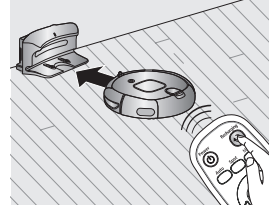

1. Premere il tasto Ricarica.

- L'icona dell'unità principale  si accende e il robot torna alla base di ricarica.

2. Per interrompere il ritorno del robot alla base di ricarica, premere il tasto .

3. Per testare la funzione di ricarica automatica, premere il tasto Ricarica quando il robot si trova a meno di 1,5 m dalla base di ricarica.

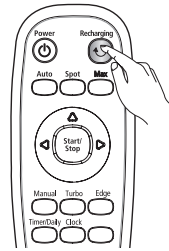

Uso del telecomando

Risoluzione dei problemi nel caso il robot aspirapolvere non ritorni alla base di ricarica

- Verificare l'installazione della base di ricarica
 - Quando la base di ricarica si trova in una posizione dalla quale non è in grado di guidare il robot fino ad essa.
 - Quando la base di ricarica si trova a una distanza superiore ai 5m dal robot aspirapolvere.
: Il robot può impiegare un tempo superiore per tornare alla base di ricarica.
- Ricaricare manualmente il robot aspirapolvere nei seguenti casi.
 - Quando la base di ricarica è situata in un angolo.
 - Quando la batteria è completamente scarica.
 - Quando il robot aspirapolvere è impigliato in un ostacolo (mobili, ecc.)
 - Quando il robot non è in grado di oltrepassare un dislivello per dirigersi alla base di ricarica.

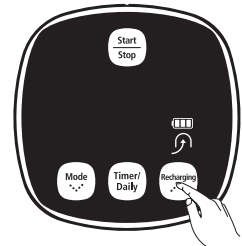

Uso dei tasti dell'unità principale

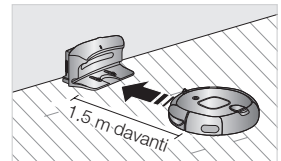

Funzionamento dell'aspirapolvere

USO DEL ROBOT ASPIRAPOLVERE

PULIZIA AUTOMATICA

Il robot aspirapolvere si muove autonomamente ed esegue la pulizia automatica della casa fino al suo completamento.

- Se le operazioni di pulizia hanno inizio quando il robot è inserito nella base di ricarica, il tempo necessario per ritornarvi sarà minore poiché il robot aspirapolvere memorizza la posizione originale durante il suo movimento.
- Se il livello di carica delle batterie è molto basso durante le operazioni di pulizia, il robot aspirapolvere tornerà automaticamente alla base di ricarica per poi riprendere la pulizia una volta ricaricate le batterie. (Numero di operazioni di pulizia riprese: una)

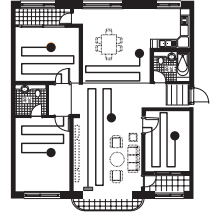

Tasto unità principale	Tasto telecomando	Sequenza configurazione
		1 Impostare la modalità.
		2 Annullare la modalità.

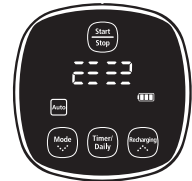

Modalità Normale

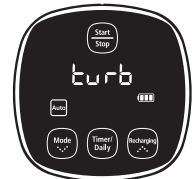

Modalità Turbo



Modalità Ostacoli



Pulizia completata



Informazioni sulla funzione Riprendi pulizia

- Se il robot aspirapolvere valuta che la pulizia è stata completata, la funzione Riprendi pulizia non viene eseguita.
- Spostando il robot aspirapolvere o premendo un tasto mentre l'unità è in carica, il robot aspirapolvere giudicherà la pulizia come completata terminando l'attività.



- Non spostare il robot aspirapolvere o premere un tasto durante la pulizia. In caso contrario, il robot aspirapolvere avvierà nuovamente la pulizia dall'inizio.
- Premendo il tasto Turbo sul telecomando, sul display apparirà il messaggio di accensione "Turbo On" (08 00 00 00) o spegnimento "Turbo Off" (08 00 00 00) della modalità. Quando viene visualizzato il messaggio "Turbo On", è possibile eseguire la pulizia del pavimento in modalità Turbo.
- Premendo il tasto Edge (Ostacoli) sul telecomando, sul display apparirà il messaggio di accensione "Ostacoli On" (0F E0 9E) o spegnimento "Ostacoli Off" (0F F E0 9E) della modalità. Quando viene visualizzato il messaggio "Ostacoli On", è possibile eseguire la pulizia del pavimento in modalità Ostacoli.
- Selezionando entrambe le modalità Turbo e Ostacoli contemporaneamente, sul display apparirà il messaggio (00 00 00 → E0 9E).

Funzionamento dell'aspirapolvere

USO DEL ROBOT ASPIRAPOLVERE

PULIZIA SPOT

E' possibile effettuare la pulizia di una zona specifica contenente ad esempio briciole di pane o di biscotti, polvere o simili.

- Posizionare il robot aspirapolvere nella zona da pulire.

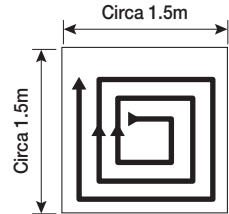

Tasto unità principale	Tasto telecomando	Sequenza configurazione
		1 Impostare la modalità.
		2 Annullare la modalità.

- Nella modalità di pulizia Spot, il robot aspirapolvere esegue la pulizia di un'area di 1,5 m x 1,5 m.
- Una volta terminata la pulizia, il robot aspirapolvere visualizzerà sul display i messaggi Fine, Arresto e Stand by.



Quando il robot aspirapolvere è inserito nella base di ricarica, la funzione di pulizia spot non è supportata.



- Premendo il tasto Turbo sul telecomando, sul display apparirà il messaggio di accensione "Turbo On" (00 00 00 00) o spegnimento "Turbo Off" (00 00 00 00) della modalità. Quando viene visualizzato il messaggio "Turbo On", è possibile eseguire la pulizia del pavimento in modalità Turbo.
- Premendo il tasto Edge (Ostacoli) sul telecomando, sul display apparirà il messaggio di accensione "Ostacoli On" (00 Ed 92) o spegnimento "Ostacoli Off" (00 Ff Ed 92) della modalità. Quando viene visualizzato il messaggio "Ostacoli On", è possibile eseguire la pulizia del pavimento in modalità Ostacoli.
- Selezionando entrambe le modalità Turbo e Ostacoli contemporaneamente, sul display apparirà il messaggio (00 00 00 → Ed 92).

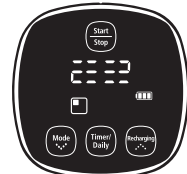

Modalità Normale

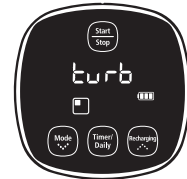

Modalità Turbo



Modalità Ostacoli

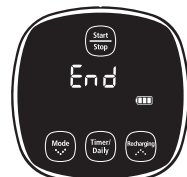

Pulizia completata

Funzionamento dell'aspirapolvere

USO DEL ROBOT ASPIRAPOLVERE

PULIZIA MAX

Il robot aspirapolvere si sposta automaticamente ed esegue la pulizia fino ad esaurimento della carica delle batterie e il livello di carica visualizzato è uno.

- Se le operazioni di pulizia hanno inizio quando il robot è inserito nella base di ricarica, il tempo necessario per ritornarvi sarà minore poiché il robot aspirapolvere memorizza la posizione originale durante il suo movimento.
- Se il livello di carica delle batterie è molto basso durante le operazioni di pulizia, il robot aspirapolvere tornerà automaticamente alla base di ricarica per poi riprendere la pulizia una volta ricaricate le batterie. (Numero di operazioni di pulizia riprese: una)

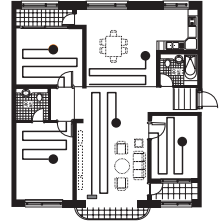

Tasto unità principale	Tasto telecomando	Sequenza configurazione
		1 Impostare la modalità.
		2 Annullare la modalità.

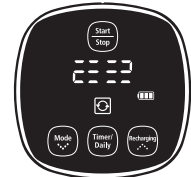

Modalità Normale



Informazioni sulla funzione Riprendi pulizia

- Se il robot aspirapolvere giudica di aver terminato la pulizia, la funzione Riprendi pulizia non verrà eseguita.
- Spostando il robot aspirapolvere o premendo un tasto mentre l'unità è in carica, il robot aspirapolvere giudicherà la pulizia come completata terminando l'attività.



- Non spostare il robot aspirapolvere o premere un tasto durante la pulizia. In caso contrario, avvierà nuovamente la pulizia dall'inizio.
- Premendo il tasto Turbo sul telecomando, sul display apparirà il messaggio di accensione "Turbo On" (08 08 08 08) o spegnimento "Turbo Off" (0F 08 08 08) della modalità. Quando viene visualizzato il messaggio "Turbo On", è possibile eseguire la pulizia del pavimento in modalità Turbo.
- Premendo il tasto Edge (Ostacoli) sul telecomando, sul display apparirà il messaggio di accensione "Ostacoli On" (0E Ed 9E) o spegnimento "Ostacoli Off" (0F F Ed 9E) della modalità. Quando viene visualizzato il messaggio "Ostacoli On", è possibile eseguire la pulizia del pavimento in modalità Ostacoli.
- Selezionando entrambe le modalità Turbo e Ostacoli contemporaneamente, sul display apparirà il messaggio (08 08 08 → Ed 9E).



Modalità Turbo



Modalità Ostacoli

Funzionamento dell'aspirapolvere

USO DEL ROBOT ASPIRAPOLVERE

PULIZIA MANUALE

E' possibile spostare il robot aspirapolvere per pulire una zona specifica usando direttamente il telecomando.

- Posizionare il robot aspirapolvere nella zona da pulire manualmente.
- E' possibile eseguire la pulizia manualmente usando solo il telecomando.

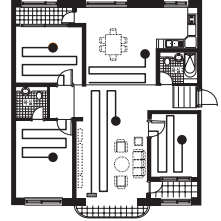

Tasto unità principale	Tasto telecomando	Sequenza configurazione
		1 Impostare la modalità.
		2 Annullare la modalità.



- Quando il robot aspirapolvere è nella base di ricarica, la funzione di pulizia manuale non è disponibile.



- Premendo il tasto Turbo sul telecomando, sul display apparirà il messaggio di accensione "Turbo On" (08E8E8E8) o spegnimento "Turbo Off" (0F88E8E8E8) della modalità. Quando viene visualizzato il messaggio "Turbo On", è possibile eseguire la pulizia del pavimento in modalità Turbo.
- Premendo il tasto Edge (Ostacoli) sul telecomando, sul display apparirà il messaggio di accensione "Ostacoli On" (0EEd9E) o spegnimento "Ostacoli Off" (0F88Ed9E) della modalità. Quando viene visualizzato il messaggio "Ostacoli On", è possibile eseguire la pulizia del pavimento in modalità Ostacoli.
- Selezionando entrambe le modalità Turbo e Ostacoli contemporaneamente, sul display apparirà il messaggio (E8E8E8→Ed9E).

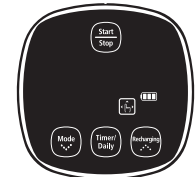

Modalità Normale

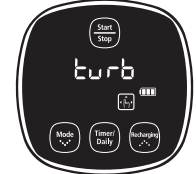

Modalità Turbo



Modalità Ostacoli

Tasti direzionali (Avanti, Sinistra, Destra)
Funzione retromarcia non disponibile.

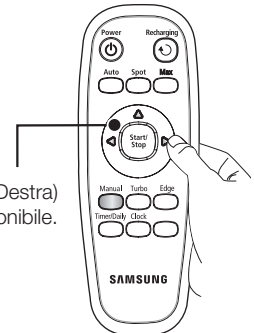

Funzionamento dell'aspirapolvere

USO DEL ROBOT ASPIRAPOLVERE

PULIZIA PROGRAMMATTA

E' possibile programmare l'inizio della pulizia a partire da uno specifico orario.

- La pulizia programmata viene eseguita solo se il robot aspirapolvere è inserito nella base di ricarica.

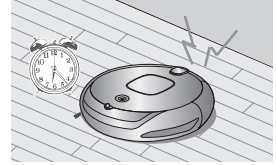

Tasto unità principale	Tasto telecomando	Sequenza configurazione	Esempio)
		1 Impostare la modalità Pulizia programmata e confermare l'orario specificato.	Orario corrente: 07:00 Orario avvio pulizia desiderato: 09:30
		2 Avviare le impostazioni.	
		3 Impostare "ora".	
		4 Confermare "ora".	
		5 Impostare "minuti".	
		6 Completare impostazioni.	
		Annullare impostazioni.	 L'icona si disattiva.

NOTA Al termine delle impostazioni e premendo il tasto (Start/Stop) al posto del tasto Avviamento ritardato/Quotidiana, si esce dalla modalità Pulizia programmata.

Funzionamento dell'aspirapolvere

USO DEL ROBOT ASPIRAPOLVERE

IMPOSTAZIONE PULIZIA QUOTIDIANA

E' possibile impostare il robot perché avvii la pulizia quotidiana all'ora desiderata.

- La pulizia quotidiana viene eseguita solo se il robot aspirapolvere è inserito nella base di ricarica.

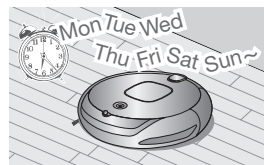

Tasto unità principale	Tasto telecomando	Sequenza configurazione	Esempio) Orario corrente: 07:00 Orario avvio pulizia desiderato: 09:30
		1 Impostare la modalità Pulizia programmata e confermare l'orario specificato (Verificare l'orario specificato per la pulizia quotidiana.)	AM 07:00
		2 Avviare le impostazioni.	AM 07: Lampeggia Daily
		3 Impostare "ora".	AM 09: Lampeggia Daily
		4 Confermare "ora".	AM 09:00 Lampeggia Daily
		5 Impostare "minuti".	AM 09:30 Lampeggia Daily
		6 Completare impostazioni.	AM 09:30 Daily
		Annullare impostazioni.	Daily L'icona si disattiva.

NOTA Al termine delle impostazioni e premendo il tasto (Start/Stop) al posto del tasto Avviamento ritardato/Quotidiana, si esce dalla modalità Pulizia programmata.

Manutenzione strumenti e filtro

USO DELLE FUNZIONI AGGIUNTIVE

E' possibile utilizzare il robot in modo più efficiente ed efficace applicando le altre funzioni di pulizia.

- La configurazione delle funzioni aggiuntive è possibile solo con il telecomando.

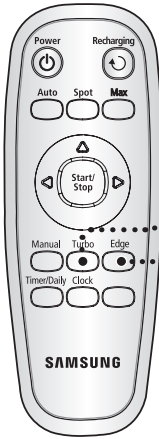

Modalità Turbo

Premendo il tasto Turbo sul telecomando, sul display apparirà il messaggio di accensione "Turbo On" (ON EE EE EE) o spegnimento "Turbo Off" (OFF EE EE EE EE) della modalità.

Turbo On (modalità Turbo): La spazzola principale ruota alla massima velocità.

Turbo Off (modalità Normale): La spazzola principale ruota a velocità normale.

Modalità Ostacoli

Premendo il tasto Edge (Ostacoli) sul telecomando, sul display apparirà il messaggio di accensione "Ostacoli On" (ON EE EE) o spegnimento "Ostacoli Off" (OFF EE EE) della modalità.

Ostacoli On (modalità Ostacoli): Il robot esegue la pulizia del pavimento toccando e seguendo il perimetro degli ostacoli che trova sul suo percorso.

Ostacoli Off (modalità Ignora ostacoli): Il robot esegue la pulizia del pavimento evitando gli ostacoli che trova sul suo percorso.



Quando il messaggio Ostacoli Off (modalità Ignora ostacoli) viene visualizzato sul display, il robot potrebbe colpire eventuali ostacoli sottili o di colore scuro che trova sul suo percorso.

PULIZIA DEL ROBOT ASPIRAPOLVERE

TENERE A MENTE I METODI DI PULIZIA E MANUTENZIONE

- Se l'interruttore di alimentazione è danneggiato, rivolgersi a un tecnico dell'assistenza per evitare eventuali incidenti.
- Non utilizzare alcuno strumento o dispositivo meccanico non previsto dal costruttore che possa deformare il robot aspirapolvere.

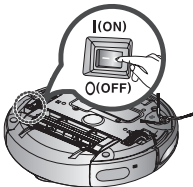

- Spegner sempre l'unità premendo il tasto di alimentazione posto sul fondo prima di effettuare la manutenzione del robot aspirapolvere. In caso contrario, il robot potrebbe attivarsi improvvisamente causando lesioni.



Manutenzione strumenti e filtro

PULIZIA DELLA SPIA DEL SENSORE E DELLA TELECAMERA

Spegnere sempre l'unità premendo il tasto di accensione posto sul fondo prima di effettuare la manutenzione del robot aspirapolvere.

- Non spruzzare acqua, diluenti, benzina o sostanze simili direttamente sul corpo del robot aspirapolvere.

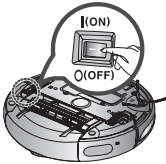

- Pulire delicatamente la spia del sensore e la telecamera usando un panno morbido.

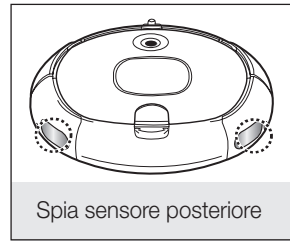
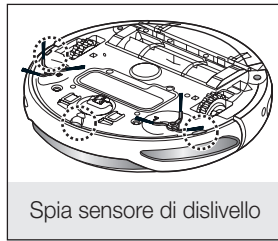
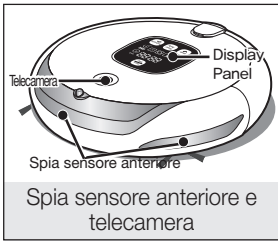

PULIZIA DEL ROBOT ASPIRAPOLVERE

SVUOTAMENTO RAPIDO DELLA VASCHETTA DI RACCOLTA POLVERE

- Utilizzando un normale aspirapolvere, è possibile svuotare la vaschetta di raccolta polvere senza doverla rimuovere dall'unità.

1. Aprire il coperchio dell'uscita polvere.

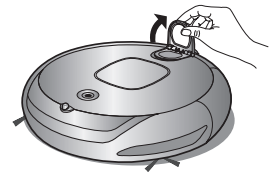

2. Posizionando il tubo dell'aspirapolvere sopra la bocchetta di uscita polvere del robot, l'aspirapolvere assorbirà la polvere direttamente dalla vaschetta, svuotandola.

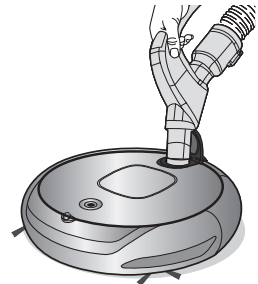

Manutenzione strumenti e filtro

PULIZIA DELLA VASCHETTA DI RACCOLTA POLVERE E DEL FILTRO

Per prima cosa, svuotare la vaschetta di raccolta polvere prima di pulirla.

- Durante l'estrazione della vaschetta, prestare attenzione a non rovesciare la polvere raccolta.
- Vuotare la vaschetta nei seguenti casi.
 1. Quando nella vaschetta si è accumulata una quantità eccessiva di polvere.
 2. Quando la Potenza di aspirazione si è ridotta.
 3. Quando improvvisamente la rumorosità è aumentata.

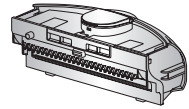

1. Premere il tasto di espulsione della vaschetta di raccolta polvere (PUSH), quindi estrarre la vaschetta.

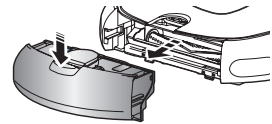

2. Separare la vaschetta estraendola nella direzione illustrata dalla freccia in figura.

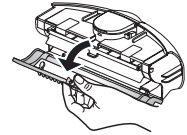

3. Separare il filtro dalla vaschetta di raccolta estraendolo nella direzione illustrata dalla freccia in figura.

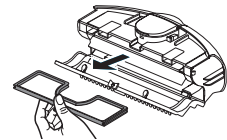

4. Pulire il filtro e la vaschetta di raccolta polvere.

* Entrambi possono essere puliti in acqua corrente.



5. Rimontare il filtro nella vaschetta di raccolta.

- Accertarsi che la griglia del filtro sia rivolta verso il basso.
Non è possibile montarlo in modo diverso.

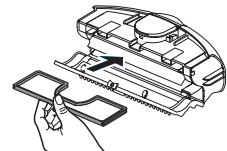

6. Chiudere il coperchio della vaschetta di raccolta polvere e reinserirla nell'unità principale.

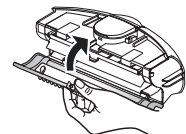

Manutenzione strumenti e filtro

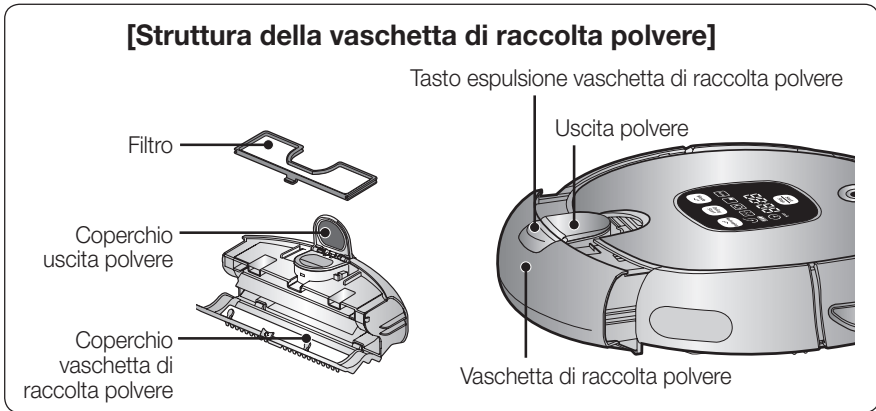

PULIZIA DEL ROBOT ASPIRAPOLVERE

PULIZIA DELLA SPAZZOLA PRINCIPALE

Spegnere sempre l'unità premendo il tasto di alimentazione posto sul fondo prima di effettuare la manutenzione del robot aspirapolvere.



- Dal momento che la polvere raccolta nella vaschetta potrebbe fuoriuscire, estrarre la vaschetta di raccolta prima di pulire la spazzola.

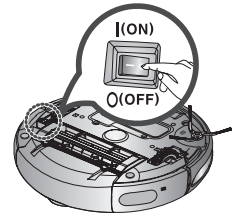

- 1. Separare la vaschetta di raccolta dal corpo dell'aspirapolvere premendo il tasto di espulsione della vaschetta (PUSH).**

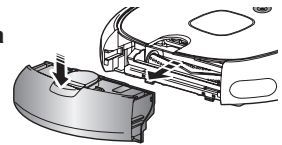

- 2. Dopo avere verificato l'eventuale presenza di corpi estranei, premere il tasto di sgancio che trattiene il coperchio della spazzola per separarlo dal corpo dell'aspirapolvere.**

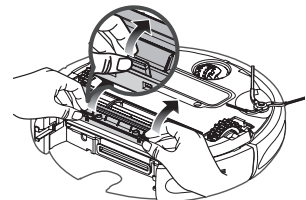

Manutenzione strumenti e filtro

PULIZIA DEL ROBOT ASPIRAPOLVERE

3. Sollevare la spazzola dal corpo dell'aspirapolvere.

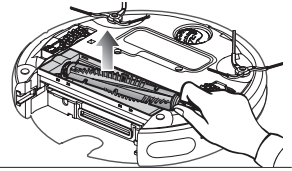

4. Rimuovere dalla spazzola eventuali corpi estranei quali capelli o filamenti usando una spazzola per la pulizia o un aspirapolvere.



5. Al termine della pulizia, fissare per prima la parte laterale della spazzola quindi l'altro lato nello stesso modo.

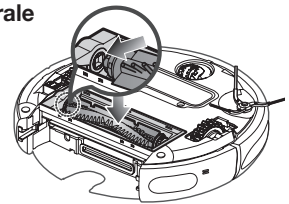

6. Dopo aver inserito i tre perni nella parte superiore del coperchio, premere la parte terminale fino ad avvertire uno scatto.

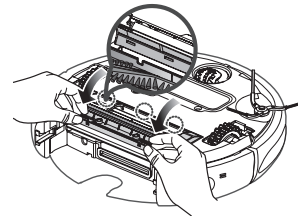

AVVERTENZA

- Al fine di prevenire l'otturazione del robot aspirapolvere, prestare attenzione a non aspirare stuzzicadenti o bastoncini di cotone.
- Se la rimozione degli oggetti è complicata, contattare il Centro di assistenza.
- Poiché il robot aspira la sporcizia presente sul pavimento, è possibile che aspiri anche capelli e altri filamenti. Controllare ed eventualmente pulire regolarmente la spazzola.

Manutenzione strumenti e filtro

PULIZIA DEL ROBOT ASPIRAPOLVERE

PULIZIA DELLE SPAZZOLE ROTATIVE LATERALI PER LA PULIZIA DEI BORDI

Spegnere sempre l'unità premendo il tasto di alimentazione posto sul fondo prima di effettuare la manutenzione del robot aspirapolvere.

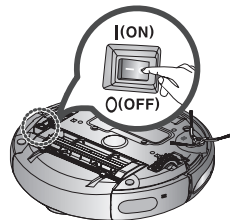

1. Verificare che le spazzola per la pulizia dei bordi non sia piegata e non presenti oggetti incastrati.

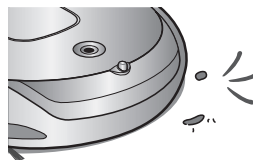

2. Indossando guanti di gomma, avvolgere la spazzola in un panno imbevuto d'acqua calda per circa 10 secondi quindi svolgere il panno.

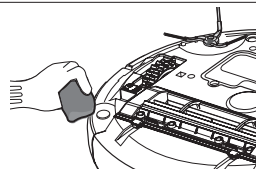

3. Ruotando la spazzola, ripetere la procedura descritta al punto 2.

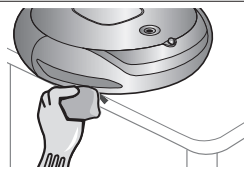

4. Se si sono incastrati capelli o filamenti tra la spazzola e il corpo dell'unità, con un cacciavite a croce svitare ed estrarre la vite di ritenuta posta sul lato della spazzola. Prima di rimontare la spazzola, verificare che il segno "L" sul bordo della spazzola e il segno "L" sul corpo principale siano allineati, quindi rimontare la spazzola. (La lettera "R" è incisa sulla parte destra della spazzola.)

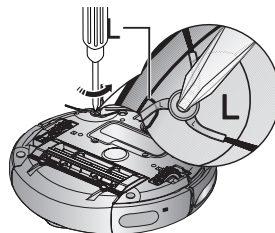

Dal momento che nella spazzola rotativa si impigliano facilmente capelli e altri corpi estranei, effettuarne frequentemente la pulizia.

Una quantità eccessiva di corpi estranei può danneggiare la spazzola.

Manutenzione strumenti e filtro

PULIZIA DEL ROBOT ASPIRAPOLVERE

PULIZIA DELLE RUOTE DI GUIDA

Spegner sempre l'unità premendo il tasto di alimentazione posto sul fondo prima di effettuare la manutenzione del robot aspirapolvere.

- Se il robot aspirapolvere inizia a procedere a zig zag, verificare che non vi siano corpi estranei incastrati fra le ruote di guida.

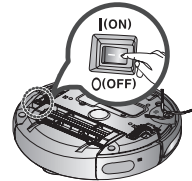

1. Nel pulire le ruote di guida, posizionare un panno morbido sul pavimento e capovolgere il corpo principale, appoggiandolo con cura.

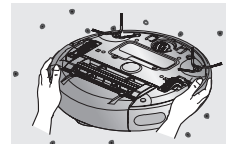

2. Verificare l'eventuale presenza di corpi estranei e rimuoverli con un bastoncino o un paio di forbici non appuntite.

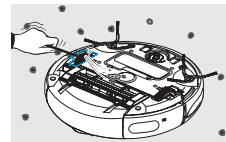

CURA E MANUTENZIONE DELLA SPAZZOLA (OPZIONE)

Un panno sporco può emettere cattivo odore. Mantere il panno sempre pulito.

1. Separare il panno dalla piastra fissata sul fondo del robot.

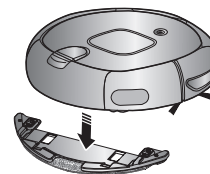

2. Rimuovere il panno dalla piastra.

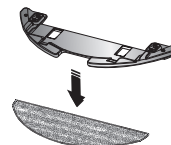

3. Lavare il panno in acqua pulita.



4. Lasciare asciugare completamente il panno in un luogo ventilato prima di utilizzarlo nuovamente.

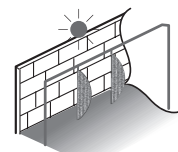

Risoluzione dei problemi

CHECKLIST PRIMA DI CHIAMARE L'ASSISTENZA

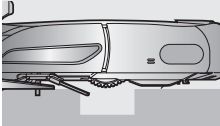
SINTOMO	CHECKLIST	MISURA DA INTRAPRENDERE
<p>Il robot aspirapolvere non funziona prima della pulizia.</p>	<ul style="list-style-type: none"> • La vaschetta di raccolta è inserita correttamente? • L'interruttore di alimentazione è in posizione On? • E' attivata la modalità di pulizia (Auto) sul display? • Lampeggia un solo settore del livello di carica della batteria e sul display compare 'LO'? • Il robot aspirapolvere non funziona quando le batterie del telecomando sono scariche. 	<ul style="list-style-type: none"> • Montare la vaschetta di raccolta polvere • Portare l'interruttore di alimentazione in posizione On. • Premere il tasto (Start/Stop). (Per spegnere il robot, tenere premuto il tasto (Start/Stop) per almeno 3 secondi.) • Sollevare il robot aspirapolvere e inserirlo manualmente nella base di ricarica per ricaricarlo. • Sostituire le batterie del telecomando. (Tipo AAA)
<p>Il robot aspirapolvere ha interrotto il funzionamento durante la pulizia.</p> 	<ul style="list-style-type: none"> • Lampeggia un solo settore del livello di carica della batteria e sul display compare 'LO'? • Il robot si è impigliato in qualche cavo sul pavimento? • Il robot si è fermato di fronte a un dislivello? - La ruota di guida si è sollevata. • Sulla spazzola si è avvolto un fazzoletto o un altro oggetto simile? • Il robot è rimasto incastrato nella soglia della porta? 	<ul style="list-style-type: none"> • Sollevare il robot aspirapolvere e inserirlo manualmente nella base di ricarica per ricaricarlo. • Spegnerlo e togliere i cavi. • Spegnere il robot aspirapolvere e spostarlo in un altro punto da pulire. • Spegnere il robot aspirapolvere e rimuovere il fazzoletto. • Spegnere il robot aspirapolvere e spostarlo in un altro punto da pulire.
<p>La potenza di aspirazione è debole.</p>	<ul style="list-style-type: none"> • Controllare se la vaschetta di raccolta polvere è piena. • Controllare se la bocchetta di aspirazione è ostruita da corpi estranei. • Controllare se il filtro è intasato. 	<ul style="list-style-type: none"> • Arrestare il robot aspirapolvere e svuotare la vaschetta di raccolta polvere. • Spegnere il robot aspirapolvere e rimuovere i corpi estranei dalla bocchetta di aspirazione. • Pulire il filtro.

Risoluzione dei problemi

CHECKLIST PRIMA DI CHIAMARE L'ASSISTENZA

SINTOMO	CHECKLIST	MISURE DA INTRAPRENDERE
Il robot aspirapolvere non è in grado di trovare la base di ricarica.	<ul style="list-style-type: none">• Verificare se la spina di alimentazione della base di ricarica sia correttamente inserita nella presa elettrica.• Rimuovere eventuali ostacoli presenti nel raggio di un 1 m davanti e 0,5 m ai lati della base di ricarica.• Se i poli di ricarica sono sporchi, pulirli con un panno asciutto.• La VIRTUAL GUARD è installata nei pressi della base di ricarica?	<ul style="list-style-type: none">• Spostare la VIRTUAL GUARD in una posizione diversa in modo che il robot possa raggiungere la base di ricarica.
Il robot aspirapolvere oltrepassa la VIRTUAL GUARD.	<ul style="list-style-type: none">• Le batterie della VIRTUAL GUARD sono esaurite?• La VIRTUAL GUARD è impostata in modalità Guard (porta virtuale)?• La lampada che indica la modalità è spenta?	<ul style="list-style-type: none">• Sostituire le batterie. (2 alcaline tipo D (LR20))• Impostare la VIRTUAL GUARD in modalità (parete virtuale).• Verificare che la VIRTUAL GUARD sia spenta, quindi impostarla nella modalità desiderata.
La durata della batteria della VIRTUAL GUARD è troppo esiguo.	<ul style="list-style-type: none">• Si stanno utilizzando batterie drycell al manganese?	<ul style="list-style-type: none">• Sostituire le batterie con nuove batterie alcaline. (2 alcaline tipo D (LR20))
Sul display appare il conteggio alla rovescia, da 30, 29, 28,...	<ul style="list-style-type: none">• Il robot aspirapolvere è stato rimosso manualmente o è stato premuto durante la ricarica?	<ul style="list-style-type: none">• Quando il robot aspirapolvere viene rimosso o premuto durante la ricarica, dopo 30 secondi torna automaticamente alla base di ricarica per una nuova sessione di carica.

Risoluzione dei problemi

RISOLUZIONE DEI PROBLEMI MEDIANTE CODICI DI ERRORE



CODICE DI ERRORE	CAUSA	SOLUZIONE
C 00	<ul style="list-style-type: none"> Il robot aspirapolvere è rimasto intrappolato o si è fermato durante il movimento. 	<ul style="list-style-type: none"> Spegnere l'unità premendo il tasto sul fondo del robot e spostarlo in una posizione diversa.
C 01	<ul style="list-style-type: none"> Un corpo estraneo (filamenti, carta, giocattoli, ecc.) è rimasto impigliato nella spazzola principale. 	<ul style="list-style-type: none"> Spegnere l'unità premendo il tasto sul fondo del robot e rimuovere il corpo estraneo impigliato nella spazzola principale.
C 02	<ul style="list-style-type: none"> Un corpo estraneo (filamenti, carta, giocattoli, ecc.) è rimasto impigliato nella ruota di guida sinistra. 	<ul style="list-style-type: none"> Spegnere l'unità premendo il tasto sul fondo del robot e rimuovere il corpo estraneo impigliato nella ruota di guida sinistra.
C 03	<ul style="list-style-type: none"> Un corpo estraneo (filamenti, carta, giocattoli, ecc.) è rimasto impigliato nella ruota di guida destra. 	<ul style="list-style-type: none"> Spegnere l'unità premendo il tasto sul fondo del robot e rimuovere il corpo estraneo impigliato nella ruota di guida destra.
C 05	<ul style="list-style-type: none"> Verificare il sensore paracolpi. 	<ul style="list-style-type: none"> Tirare leggermente verso l'esterno il paracolpi incastrato.
C 06	<ul style="list-style-type: none"> La spia del sensore Ostacoli è sporca (polvere, macchie o altro). 	<ul style="list-style-type: none"> Spegnere l'unità premendo il tasto sul fondo del robot e pulire la spia del sensore anteriore e posteriore usando un panno morbido.
C 07	<ul style="list-style-type: none"> La spia del sensore di dislivello è sporca (polvere, macchie o altro). 	<ul style="list-style-type: none"> Spegnere l'unità premendo il tasto sul fondo del robot e pulire la spia del sensore di dislivello usando un panno morbido.
C 08	<ul style="list-style-type: none"> La vaschetta di raccolta polvere non è inserita. 	<ul style="list-style-type: none"> Inserire la vaschetta di raccolta polvere fino ad avvertire un "clic".
C 09	<ul style="list-style-type: none"> Un corpo estraneo (filamenti, indumenti, ecc..) è rimasto intrappolato nelle spazzole rotative laterali per la pulizia dei bordi. 	<ul style="list-style-type: none"> Spegnere l'unità premendo il tasto sul fondo del robot e rimuovere il corpo estraneo impigliato nelle spazzole.

* Premendo il tasto Avvio/Arresto o il tasto di alimentazione, il codice di errore scompare.

Specifiche del prodotto

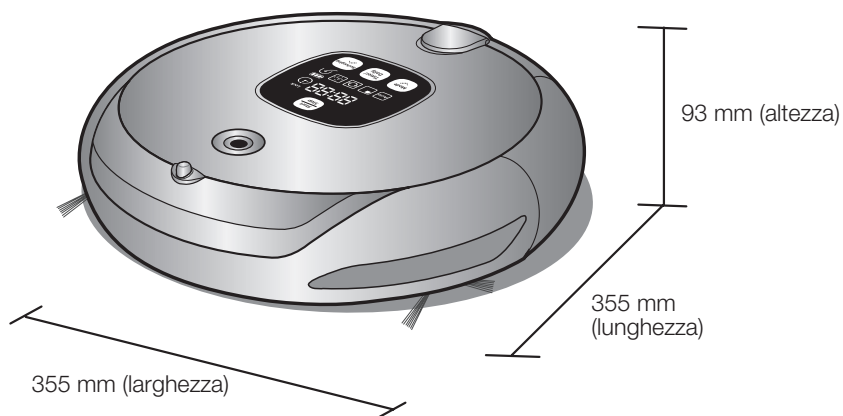

Corpo principale

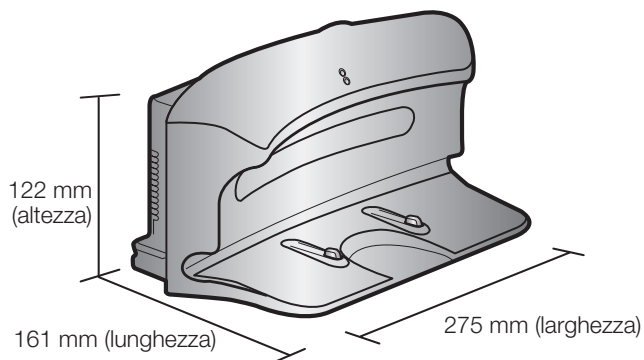

Base di ricarica (Stazione)

Specifiche del prodotto

CLASSIFICAZIONE	ARTICOLO	DETTAGLIO
Specifiche meccaniche	Diametro	355mm
	Altezza	93mm
	Peso	4.0kg
Specifiche elettriche	Tensione di corrente	AC 220-240V~, 50-60Hz
	Consumo elettrico per la ricarica	50 W
	Consumo elettrico dell'unità principale	40 W
	Specifiche delle batterie	14.4V / 2,000 mA
Specifiche di pulizia	Capacità vaschetta di raccolta polvere	Circa 0.6 ℓ
	Tipo di ricarica	Ricarica automatica/Ricarica manuale
	Modalità di pulizia	Auto, Spot, Max, Manuale, Pulizia programmata, Impostazione della pulizia quotidiana
	Tempo di ricarica	Circa 120 minuti
	Durata pulizia (calcolato sulla base di pavimenti con superfici lisce)	Circa 90 minuti
Metodo di pulizia		Riconoscimento forma soffitto
Tipo tasto unità principale		a sfioramento

Questo aspirapolvere è approvato per quanto segue:

Direttiva sulla compatibilità elettromagnetica : 2004/108/EEC

Direttiva sulla sicurezza di bassa tensione : 2006/95/EC



Se avete commenti o domande sui prodotti Samsung,
contattate il Servizio Clienti Samsung.
800-SAMSUNG(726-7864)
www.samsung.com



SR8894
SR8895

Robo-Sauger Benutzerhandbuch

Planet
First

100%
Recycled Paper

Dieses Handbuch ist zu 100% auf Recyclingpapier gedruckt.

- * Lesen Sie die Anweisungen sorgfältig durch, ehe Sie das Gerät in Betrieb nehmen.
- * Nur zum Einsatz in geschlossenen Räumen geeignet.

Deutsch

imagine the possibilities

Wir freuen uns, dass Sie sich für ein Samsung-Produkt entschieden haben!

Produkt registrieren und gewinnen unter
www.samsung.com/register

SAMSUNG

Sicherheitsinformationen

SICHERHEITSINFORMATIONEN



- Bitte lesen Sie die Bedienungsanleitung gründlich durch, und bewahren Sie sie zum späteren Nachschlagen auf.



- Da die folgenden Hinweise zum Betrieb für verschiedene Modelle gelten, können die Eigenschaften Ihres Staubsaugers sich leicht von den in diesem Handbuch beschriebenen unterscheiden.

SYMBOLE DER GEFAHREN-/WARNHINWEISE



Dieses Zeichen weist darauf hin, dass Lebensgefahr oder ein ernsthaftes Verletzungsrisiko besteht.



Dieses Zeichen weist darauf hin, dass die Gefahr von Personen- oder Sachschäden besteht.

WEITERE VERWENDETE SYMBOLE



Dieses Zeichen weist darauf hin, dass Erklärungen folgen, damit die Benutzer besser verstehen, wie sie das Gerät richtig verwenden sollen.

Sicherheitsinformationen

WICHTIGE HINWEISE ZUR SICHERHEIT

Beim Umgang mit Elektrogeräten sind einige grundlegende Vorsichtsmaßnahmen wie u.a. die folgenden zu beachten:

LESEN SIE VOR DER VERWENDUNG IHRES ROBO-SAUGERS SÄMTLICHE ANWEISUNGEN GRÜNDLICH DURCH.

Ziehen Sie den Stecker aus der Steckdose, wenn Sie das Gerät nicht verwenden, und ehe Sie Wartungsarbeiten durchführen.

WARNING: So verringern Sie die Gefahr von Brand, Stromschlag oder Verletzungen:

ALLGEMEIN

- Verwenden Sie das Gerät nur wie in diesem Handbuch beschrieben.
- Verwenden Sie das Gerät nicht, wenn der Robo-Sauger oder das Ladegerät beschädigt wurden.
- Wenn der Staubsauger nicht so arbeitet, wie er sollte, hingefallen oder beschädigt ist, im Freien vergessen oder in Wasser getaucht wurde, geben Sie ihn an ein Kundendienstcenter zurück.
- Berühren Sie das Ladegerät und den Robo-Sauger nicht mit nassen Händen
- Verwenden Sie ihn nur für trockene Flächen in geschlossenen Räumen.
- Dieses Gerät soll nicht von Personen (auch Kindern) mit verminderten körperlichen, sensorischen oder geistigen Fähigkeiten oder einem Mangel an Erfahrung und Wissen bedient werden. Von dieser Regel darf nur abgewichen werden, wenn diese Personen unter Aufsicht stehen oder durch eine für ihre Sicherheit verantwortliche Person eine Unterweisung zur Bedienung des Geräts erhalten haben.
- Kinder müssen beaufsichtigt werden, damit sie nicht mit dem Gerät spielen können.

AKKULADEGERÄT

- Verwenden Sie das Gerät nicht im Freien oder auf nassen Flächen.
- Ziehen Sie den Stecker des Ladegeräts aus der Steckdose, wenn Sie es nicht verwenden, und ehe Sie Wartungsarbeiten durchführen.
- Verwenden Sie nur das vom Hersteller mitgelieferte Ladegerät.
- Verwenden Sie das Gerät nicht mit einem beschädigten Kabel oder Stecker.
- Ziehen und tragen Sie das Gerät nicht am Kabel und verwenden Sie das Kabel nicht als Tragegriff. Ziehen Sie das Kabel auch nicht um scharfe Kanten oder Ecken herum. Halten Sie das Kabel entfernt von beheizten Oberflächen.
- Verwenden Sie keine Verlängerungskabel oder Steckdosen mit unzureichender Leistung.
- Ziehen Sie zum Ausstöpseln nicht am Netzkabel. Um den Stecker herauszuziehen, fassen Sie den Stecker, nicht das Kabel an.
- Beschädigen und verbrennen Sie Akku und Batterien nicht, da sie bei hohen Temperaturen explodieren.
- Versuchen Sie keinesfalls, das Ladegerät zu öffnen. Reparaturen dürfen nur durch ein qualifiziertes Kundendienstcenter vorgenommen werden.
- Setzen Sie das Ladegerät keinen hohen Temperaturen aus und lassen Sie weder Feuchtigkeit noch Nässe in irgendeiner Form in Kontakt mit dem Ladegerät kommen.

Sicherheitsinformationen

ROBO-SAUGER

- Saugen Sie keine harten oder scharfen Gegenstände wie Glas, Nägel, Schrauben, Münzen usw. auf.
- Verwenden Sie den Staubsauger niemals ohne Filter. Wenn Sie Wartungsarbeiten am Gerät durchführen, stecken Sie niemals Ihre Finger oder andere Gegenstände in die Lüfterkammer, denn das Gerät könnte sich möglicherweise ungewollt einschalten.
- Bringen Sie keine Objekte in die Öffnungen des Geräts. Verwenden Sie das Gerät nicht mit versperrten Öffnungen. Halten Sie Öffnungen frei von Staub, Fusseln, Haaren und anderen Stoffen, die die Luftströmung behindern könnten.
- Saugen Sie keine toxischen Stoffe (Chlorbleiche, Ammoniak, Abflussreiniger usw.) auf.
- Saugen Sie nichts auf, was brennt oder Rauch erzeugt (z. B. Zigaretten, Streichhölzer oder heiße Asche).
- Verwenden Sie das Gerät nicht, um leicht entzündliche oder brennbare Flüssigkeiten wie Benzin aufzusaugen, und setzen Sie es nicht an Stellen ein, wo solche Stoffe vorhanden sein könnten.
- Verwenden Sie den Robo-Sauger nicht in geschlossenen Räumen, wenn die Luft darin Dämpfe von Lösungsmittelhaltigen Farben, Lackverdünner, Mottenschutzmittel, brennbaren Stäuben oder andere explosive bzw. toxische Dämpfe enthält.
- Akkus und Batterien können bei extremen Einsatz- oder Temperaturbedingungen auslaufen. Wenn diese Flüssigkeit auf die Haut kommt, waschen Sie sie schnell mit Wasser ab. Wenn die Flüssigkeit in die Augen kommt, spülen Sie sie sofort und mindestens 10 Minuten lang mit sauberem Wasser. Suchen Sie medizinische Hilfe.

Inhalt

SICHERHEITSINFORMATIONEN	06 Elektrische Sicherheit
	07 Vor Inbetriebnahme
	10 Im Einsatz
	11 Reinigung und Wartung
02	
PRODUKTMERKMALE	13 Produktmerkmale
13	
INBETRIEBNAHME DES ROBO-SAUGERS	15 Komponenten
	16 Bezeichnungen der Teile
15	
GEBRAUCH DES ROBO-SAUGERS	20 Zusammensetzen des Robo-Saugers
	20 Reihenfolge bei Inbetriebnahme
	20 Ein- und Ausschalten des Geräts
	21 Installieren des Ladegeräts
	22 Laden
	23 Informationen zum Akku
	24 Einstellen der Uhrzeit
	25 Einstellen des VIRTUAL GUARD
	27 Befestigen des Mikrofaser-Vlieses (option)
	28 Verwenden des Robo-Saugers
	28 Starten/Stoppen des Robo-Saugers
	29 Aufladen
	30 Automatisches Saugen
	31 Punktuell saugen
	32 Maximalsaugen
	33 Manuelles Saugen
	34 Startzeitvorwahl
	35 Einstellen von täglichem Reinigen
	36 Verwenden von Spezialfunktionen (Turbomodus, Kantenmodus)
	36 Reinigen des Robo-Saugers
	36 Beachten Sie die Reinigungs- und Wartungshinweise
	37 Reinigen des Sensorfensters und der Kamera
	37 Schnelles Entleeren des Staubbehälters
	38 Reinigen des Staubbehälters und des Filters
	39 Reinigen der Hauptbürste
	41 Reinigen der Seitenbürsten für die Kantenreinigung
	42 Reinigen der Antriebsräder
	42 Reinigen des Mikrofaser-Vlieses (option)
	43 Checkliste zur Selbsthilfe
	45 Fehlerbehebung und Fehlercodes
GEBRAUCH UND WARTUNG VON ZUBEHÖR	
36	
FEHLERBEHEBUNG	
43	
TECHNISCHE DATEN	46 Technische Daten
46	

Sicherheitsinformationen

ELEKTRISCHE SICHERHEIT



Vermeiden Sie übermäßiges Verbiegen des Kabels. Stellen Sie keine schweren Gegenstände darauf ab, sodass es brechen könnte.

- Andernfalls besteht die Gefahr von Stromschlägen oder Brand.

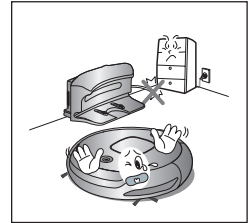

Entfernen Sie Schmutz und Wasser vom Netzstecker.

- Andernfalls besteht die Gefahr von Stromschlägen oder Störungen des Geräts.

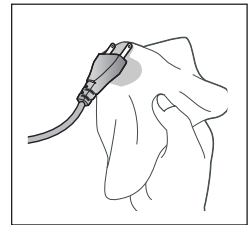

Ziehen Sie niemals am Kabel, um den Netzstecker aus der Steckdose zu ziehen, und berühren Sie den Netzstecker nicht mit nassen Händen

- Andernfalls besteht die Gefahr von Stromschlägen oder Brand.

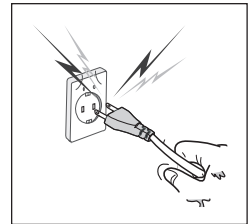

Schließen Sie nicht mehrere Geräte an eine Steckdose an. (Lassen Sie das Kabel nicht ungeschützt auf dem Boden herumliegen.)

- Andernfalls besteht die Gefahr von Stromschlägen oder Brand.

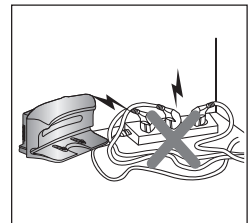

Verwenden Sie niemals beschädigte oder lose Netzkabel, Netzstecker oder Steckdosen.

- Andernfalls besteht die Gefahr von Stromschlägen oder Brand.

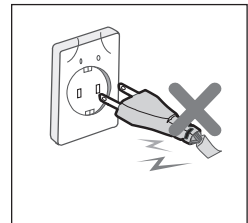

Sicherheitsinformationen

VOR INBETRIEBNAHME



Stellen Sie vor dem Aktivieren des Robo-Saugers sicher, dass der Staubbehälter zusammengebaut ist.

- Wenn der Staubbehälter nicht eingesetzt wurde, kann der Robo-Sauger nicht funktionieren.

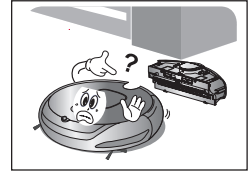

Verwenden Sie den Robo-Sauger nie in Räumen mit brennbarem Material wie :

- Räume mit Kerzen oder Schreibtischlampen auf dem Boden.
- Räume mit unbeaufsichtigtem Feuer (Feuer oder Glut).
- Räume, in denen sich Benzin, Alkohol, Verdüner, Aschenbecher mit brennenden Zigaretten usw. befinden

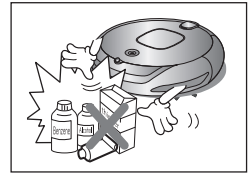

Der Robo-Sauger ist nur zum Gebrauch im Haushalt bestimmt. Verwenden Sie ihn niemals in folgenden Räumlichkeiten:

- Dachböden, Keller, Lagerhäuser, Industriegebäude, isolierte Zimmer, die weit vom Hauptgebäude entfernt sind, Feuchträumen (z. B. Badezimmer oder Waschküchen) sowie schmale und hochgelegene Flächen (z. B. Tischen oder Regale). Bei Einsatz in solchen Bereichen können schwerste Schäden (Betriebsstörungen und Bruch) auftreten.



Öffnen Sie alle Türen, damit alle Zimmer gesaugt werden.

- Wenn eine Tür geschlossen ist, kann der Robo-Sauger nicht in dieses Zimmer gelangen.
- Vergewissern Sie sich jedoch, dass die Haustür, die Terrassentür, die Badezimmertür sowie Türen zu anderen Räumen geschlossen sind, um einen eventuellen Absturz des Robo-Saugers zu verhindern.



Bei Teppichen mit langen Fransen schieben Sie die Fransen unter den Teppich.

- Wenn Sie die Fransen nicht unter den Teppich schieben, kann es zu schwersten Schäden am Teppich und der Maschine selbst kommen, wenn sich die Fransen im Antriebsrad oder der Hauptbürste verfangen.

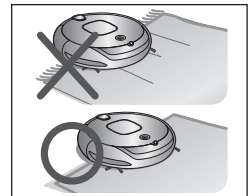

Wenn der Höhengsensor verunreinigt ist, kann der Robo-Sauger möglicherweise an Treppen oder Geländern herunterfallen.

Dies kann Personenschäden und schwerste Beschädigungen am Gerät verursachen. Um dieses Risiko auszuschließen, installieren Sie vor gefährlichen Bereichen VIRTUAL GUARDS (Einstellung: Zaunmodus). Reinigen Sie das Sensorfenster und die Kamera, damit keine falschen Befehle empfangen werden.

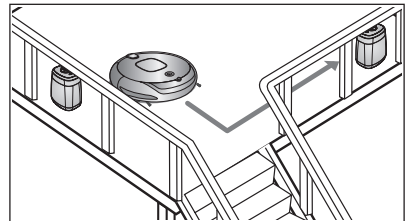

Sicherheitsinformationen

VOR INBETRIEBNAHME



Entfernen Sie kleine Objekte oder harte Gegenstände vor dem Staubsaugen aus dem zu reinigenden Bereich.

- Vergewissern Sie sich vor dem Saugen, dass keine Gegenstände herumliegen.
- Vergewissern Sie sich, dass keine zerbrechlichen Gegenstände (z. B. Porzellan, Glasobjekte, Blumenvasen usw.) herumstehen.
- Der Robo-Sauger erkennt weder Münzen, noch Ringe oder andere wertvolle Sachen (z. B.: Schmuck).



Entfernen Sie vor dem Staubsaugen alle Gegenstände, die auf dem Boden herumliegen.

- Der Robo-Sauger erkennt Hindernisse in einer Entfernung von 5 cm.
- Badehandtücher, Abtreter vor Badezimmern und Waschbecken, Eingängen, Besenkammern, Netzkabel, Tischtücher oder Gürtel können sich im Antriebsrad oder der Hauptbürste verfangen. Dadurch können Gegenstände vom Tisch fallen.



Informieren Sie alle Familienmitglieder oder andere betroffene Personen über die Reinigungszeiten des Robo-Saugers (sofort oder später mit der Startzeitvorwahl).

- Der Robo-Sauger kann Kinder anfahren, sodass sie umfallen.



Stellen Sie sicher, dass Kinder nicht auf den Robo-Sauger treten oder sich daraufsetzen.

- Kinder könnten hinfallen und sich verletzen oder es könnten schwerste Schäden am Gerät auftreten.



Wenn ein Kind oder Haustier alleine zu Hause ist, vergessen Sie nicht, den Robo-Sauger mit dem Netzschalter auszuschalten.

- Der Robo-Sauger könnte ihre Aufmerksamkeit erregen.
- Wenn das rotierende Rad oder die rotierende Bürste Finger, Füße, Kleidung oder Haare einfängt, kann dies zu Verletzungen führen.
- Wenn ein Kind oder ein Haustier im Weg des Robo-Saugers steht, kann es als Hindernis identifiziert werden, und der entsprechende Bereich wird möglicherweise nicht gereinigt.
- Wenn das Gerät am Netzschalter ausgeschaltet wird, wird die Stromversorgung getrennt und sämtliche Funktionen werden deaktiviert.

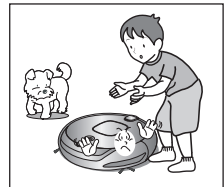

Wenn Sie die Ladestation installieren, lassen Sie das Netzkabel nicht ungeschützt auf dem Boden herumliegen.

- Wenn der Robo-Sauger automatisch aufgeladen wird und an der Ladestation vorbeifährt, kann es passieren, dass er das Netzkabel mit sich schleift.

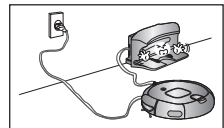

Lassen Sie das Netzkabel des Ladegeräts immer in der Steckdose.

- Obwohl der Robo-Sauger eine Selbstladefunktion besitzt, kann seine sein Akku nicht automatisch geladen werden, wenn das Netzkabel der Ladestation nicht mit der Steckdose verbunden ist

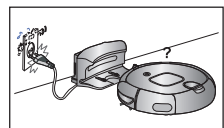

Sicherheitsinformationen

VOR INBETRIEBNAHME



Stellen Sie das Ladegerät an einer Stelle auf, die für den Robo-Sauger gut zugänglich ist.

- Wenn das Ladegerät in einer Ecke aufgestellt wird, kann dies zusätzliche Bewegungen verursachen und den automatischen Ladeprozess stören.

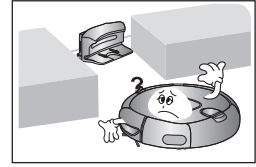

Gegenstände vor dem Ladegerät verhindern, dass der Robo-Sauger automatisch geladen wird.

- Stellen Sie sicher, dass der Robo-Sauger ungehindert die Ladestation erreichen kann.

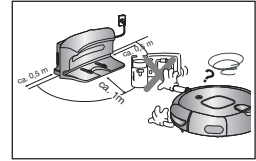

Es dürfen sich im Abstand von seitlich 0,5 m und nach vorn 1 m von der Ladestation keine Hindernisse befinden.

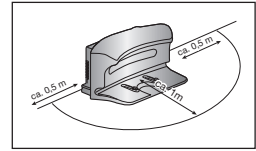

Schließen Sie die Ladekontakte nicht mit Metallobjekten wie Stäbchen, Schraubendrehern usw. kurz.

- Dies führt zu schwersten Schäden am Ladegerät.

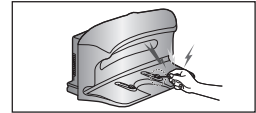

Vergewissern Sie sich, dass es auf der Ladestation keinerlei Flüssigkeiten gibt.

- Andernfalls besteht die Gefahr von Stromschlägen oder Brand.



Vergewissern Sie sich, dass der Robo-Sauger sich nicht über Flüssigkeiten (z. B. Wasser, Öl oder Tierurin) bewegt und diese womöglich aufsaugt.

- Dies kann zu schwersten Schäden am Gerät führen.
- Die Flüssigkeiten können sich über die Räder ausbreiten und so zu Verunreinigungen führen.

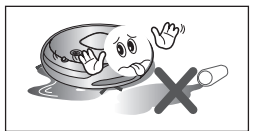

Verwenden Sie das Gerät niemals auf schwarzen Böden.

- In diesen Bereichen ist der korrekte Betrieb des Geräts nicht gewährleistet.

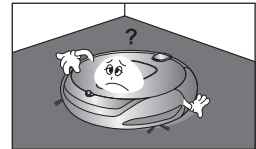

Verwenden Sie das Ladegerät niemals für andere Zwecke.

- Dies kann zu schwersten Schäden am Gerät führen und einen Brand verursachen.

Sicherheitsinformationen

IM EINSATZ



Sie können den Robo-Sauger nicht auf hochflorigen Teppichen einsetzen.

- Es kann zu Beschädigungen am Robo-Sauger kommen.
- Dies kann zu Schäden am Teppich führen.

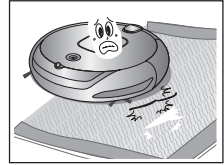

Verwenden Sie den Robo-Sauger nicht auf Tischen oder an anderen erhöhten Stellen.

- Dies kann zu Schäden am Gerät führen, wenn er während des Betriebes herunterfällt.



Der Robo-Sauger kann im Betrieb gegen Möbel (z. B. Stuhlbeine, Tischbeine, dünne und lange Möbel usw.) stoßen.

- Für schnellere und bessere Säuberung stellen Sie Stühle auf den Tisch.

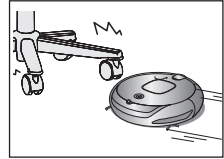

Stellen Sie keine Gegenstände auf den Robo-Sauger.

- Andernfalls besteht die Möglichkeit von Störungen.



Entfernen Sie große Papierstücke und Plastiktüten beim Saugen sofort aus dem Robo-Sauger.

- Wenn Sie das Gerät über einen längeren Zeitraum hinweg mit verstopftem Lufteinlass verwenden, kann es zu schwersten Schäden am Gerät kommen.

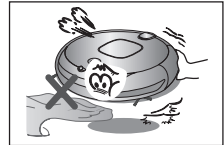

Wenn am Robo-Sauger ungewöhnliche Geräusche, Geruch oder Rauch auftreten, schalten Sie das Gerät sofort mit dem Netzschalter aus und rufen Sie das Kundendienstzentrum an.

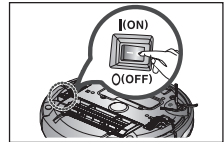

Möglicherweise kann der Robo-Sauger seinen Betrieb nicht fortsetzen, wenn er an Türschwellen hängen bleibt.

- Der Robo-Sauger stellt aus Sicherheitsgründen den Betrieb ein, wenn er sich mehr als 5 Minuten lang nicht bewegen kann.
- Um weiter zu saugen, schalten Sie den Robo-Sauger mit dem Netzschalter aus und wieder ein, nachdem Sie ihn an eine Stelle gebracht haben, wo er sich wieder bewegen und saugen kann.

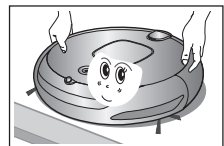

Sicherheitsinformationen

IM EINSATZ



Der Robo-Sauger kann schwer erreichbare Stellen nicht zu 100% reinigen (z. B. Ecken und Flächen zwischen Sofa und Wand).

- Reinigen Sie diese Stellen bitte gelegentlich selbst.

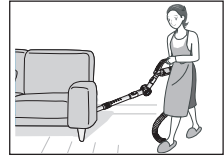

Staubansammlungen, die sich beim Saugen gebildet haben, können nach dem Saugen zurückbleiben, wenn der Robo-Sauger es nicht schafft, sie aufzusaugen.

- Fegen Sie den Staub in diesem Fall mit einem anderen Reinigungsgerät zusammen.



Der Robo-Sauger kann sich nicht über Teppiche bewegen, wenn das Mikrofaser-Reinigungsvlies am Sauger befestigt ist. (Option)

- Zum Reinigen von Teppichen nehmen Sie das Vlies und die Vlies-Trägerplatte vom Sauger ab.



Das Gerät ist nicht für die Verwendung mit feuchtem Mikrofaser-Vlies geeignet. (Option)



REINIGUNG UND WARTUNG



Wenn Sie das Gerät reinigen, dürfen Sie kein Wasser direkt auf die Außenflächen sprühen oder es mit Chemikalien wie Reinigungsbenzin, Verdüner oder Alkohol abwischen.

- Dies kann zu schwersten Schäden am Gerät führen.

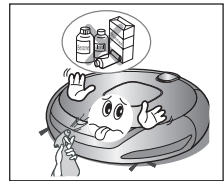

Drücken Sie nicht mit Kraft gegen die Stoßfänger des Robo-Saugers.

- Wenn der Stoßdämpfersensor beschädigt wird, kann der Robo-Sauger gegen Wände oder Möbel stoßen.

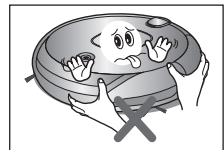

Das Gerät darf ausschließlich von qualifizierten Servicetechnikern auseinander genommen oder zusammengebaut werden.

- Andernfalls kann es zu schwersten Schäden am Gerät kommen.



Sicherheitsinformationen

REINIGUNG UND WARTUNG



Entfernen Sie regelmäßig Fremdstoffe, die sich auf Hindernis- und Absturzsensoren angesammelt haben.

- Schmutz, der sich auf den Sensoren ansammelt, bewirkt ungenaue Messungen der Sensoren.

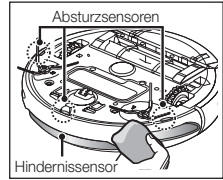

Zum Entfernen von Fremdstoffen schalten Sie zuerst das Gerät am Netzschalter aus, dann können Sie Fremdstoffe mit der Reinigungsbürste entfernen.

- Andernfalls kann das Gerät möglicherweise unerwartet in Betrieb gehen und Verletzungen oder schwerste Schäden am Gerät verursachen.

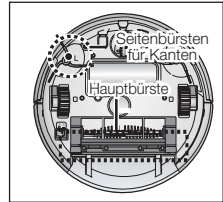

Wenn das Netzkabel beschädigt ist, lassen Sie es durch einen qualifizierten Servicetechniker in unserem Kundendienstcenter ersetzen.

- Andernfalls besteht die Gefahr von Stromschlägen oder Brand.



Vergewissern Sie sich vor dem Reinigen des Ladegeräts zu Ihrer Sicherheit, dass das Netzkabel aus der Steckdose gezogen ist.



Nach der Verwendung waschen Sie das Mikrofaser-Vlies aus und lassen es vollständig trocknen, ehe Sie es wieder verwenden. (Option)

- Andernfalls können schlechte Gerüche entstehen.

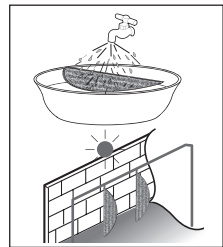

Wenden Sie sich an das Kundendienstcenter von Samsung Electronics, um den Akku ersetzen zu lassen.

- Bei Verwendung anderer als der Originalakkus kommt es zu Gerätestörungen.

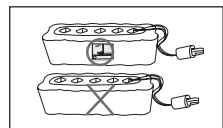

Produktmerkmale

MEHR BEQUEMLICHKEIT DURCH DIE VIRTUAL GUARD-FUNKTION

Sie können den Robo-Sauger mit einem elektronischen Zaun (virtuelle Wand, oder auch Virtual Wall) auf einen bestimmten Bereich beschränken, oder mehrere Bereiche nacheinander reinigen, indem Sie den elektronischen Wächter (virtuelle Tür, oder auch Virtual Door) verwenden.

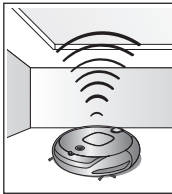

• Was ist die Deckenformerkennung (Visionary mapping™)?

Diese Funktion erkennt die Form der Decke mit Hilfe der oben eingebauten Kamera, um den Bereich zu bestimmen, der gereinigt werden soll. Sie bestimmt dabei den besten Weg, um jeden Bodenbereich zu reinigen.

GRÜNDLICHE ECKENREINIGUNG

Mit der Randabsaugung werden auch die Ecken gründlich gereinigt. Hierbei werden die Ränder des erfassten Raumgrundrisses abgesaugt.

VERSCHIEDENE REINIGUNGSMODI

Es gibt verschiedene Reinigungsmodi, die all Ihre Anforderungen erfüllen werden.

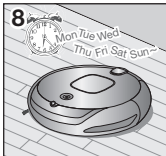
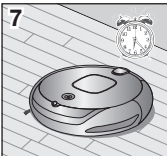
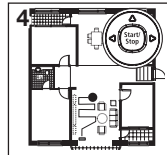
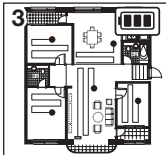
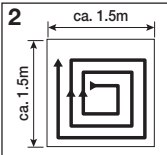
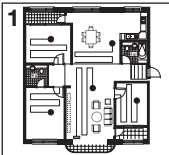

1. Automatikbetrieb:

Reinigt alle Zimmer automatisch.

2. Punktueller Saugen: Reinigt einen abgegrenzten Bereich intensiv. Diese Betriebsart kann verwendet werden, um z. B. Brot- oder Kekskrümel zu reinigen.

3. Maximalmodus: Der Sauger läuft, bis der Akku fast ganz leer ist.

4. Manuelles Saugen: Sie können den Boden auch manuell reinigen, indem Sie den Robo-Sauger mit einer Fernbedienung lenken.

5. Turbomodus: In diesem Modus läuft die Hauptbürste mit maximaler Drehzahl und sorgt so für eine besonders intensive Reinigung (mit der Fernbedienung einstellbar).

6. Kantenmodus: Wenn ein Hindernissensor beim Saugen ein Hindernis erkennt, reduziert der Robo-Sauger seine Geschwindigkeit, um die Auswirkung der Kollision zu reduzieren, und der Stoßdämpfersensor hilft dabei.

7. Startzeitvorwahl: Zur angegebenen Zeit reinigt der Robo-Sauger den Boden.

8. Modus für tägliche Reinigung: Der Robo-Sauger reinigt den Boden jeden Tag zur angegebenen Zeit.

EINFACHES ENTLEREEN DES STAUBBEHÄLTERS

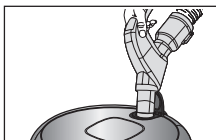

Da der Staubbehälter von oben erreicht werden kann, können Sie ihn mit einem normalen Staubsauger entleeren, ohne dass Staub austritt.

Produktmerkmale

AUTOMATIKBETRIEB

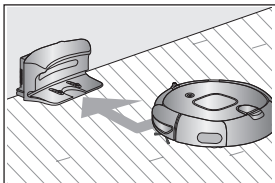

Wenn der Akku schwach ist, wird der Robo-Sauger automatisch zum Ladegerät geführt, damit er automatisch geladen werden kann.

ROTIERENDE SEITENBÜRSTEN

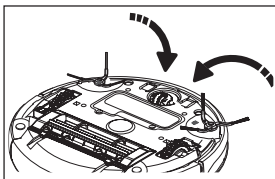

Die rotierenden Seitenbürsten entfernen Staub von Rändern und Kanten

ÜBERQUERUNG VON TÜRSCHWELLEN

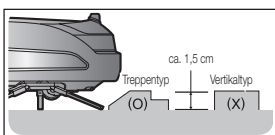

Das innovative Fahrsystem des Robo-Saugers macht es möglich, dass er Türschwellen bis zu einer Höhe von etwa 1,5 cm überquert und die Zimmer dahinter reinigt. Je nach Form der Türschwelle besteht die Möglichkeit, dass der Robo-Sauger eine 1,5 cm hohe Schwelle nicht überqueren kann.

KOLLISIONSSCHUTZ

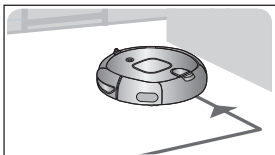

Der Robo-Sauger erkennt Hindernisse in 2 Stufen und umgeht sie. In Stufe 1 erkennen die 8 Hindernissensoren eventuelle Hindernisse und, falls der Robo-Sauger trotzdem mit einem Hindernis kollidieren sollte, absorbieren die 2 Stoßdämpfersensoren in Stufe 2 den Stoß.

STURZSICHERUNG

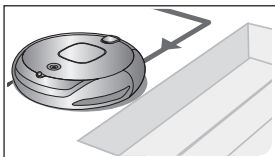

Die 3 Absturzsensoren erkennen abwärts führende Stufen oder die Schwelle der Haustür und verhindern so, dass der Robo-Sauger hinunterfällt.

SICHERHEITSVORRICHTUNG

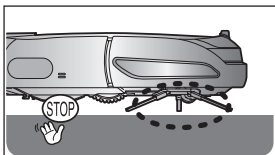

Wenn der Robo-Sauger im Betrieb hochgehoben wird, hält ein Sensor automatisch die Antriebsräder, die Hauptbürste, den Saugmotor und die rotierenden Seitenbürsten an.

Inbetriebnahme des Robo-Saugers

KOMPONENTEN

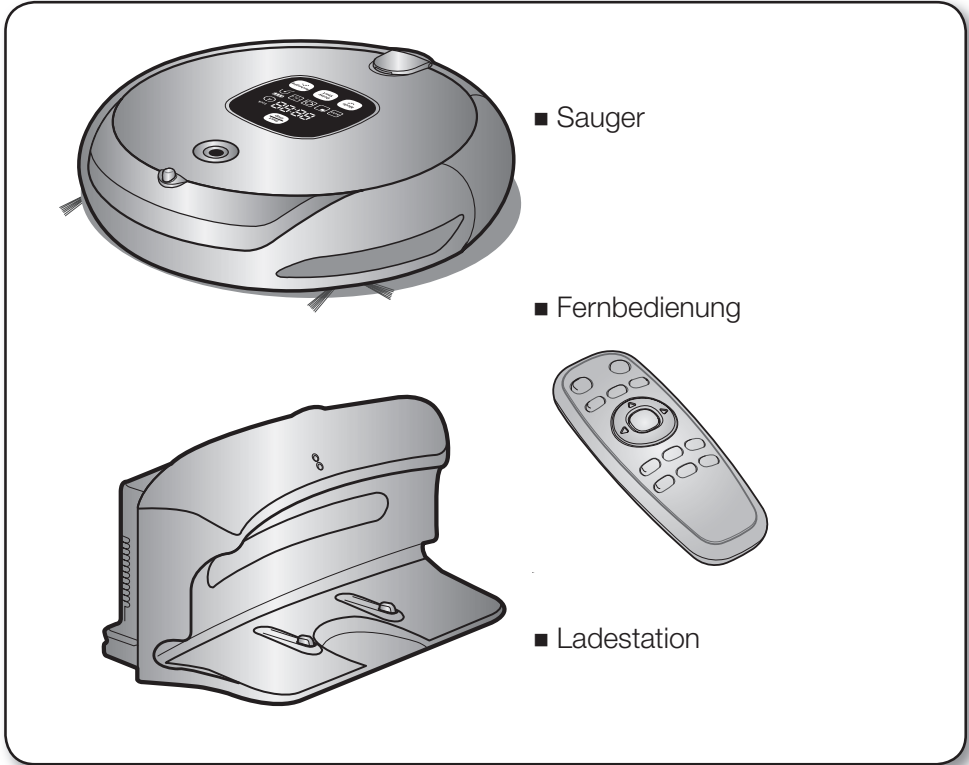

■ Weiteres Zubehör

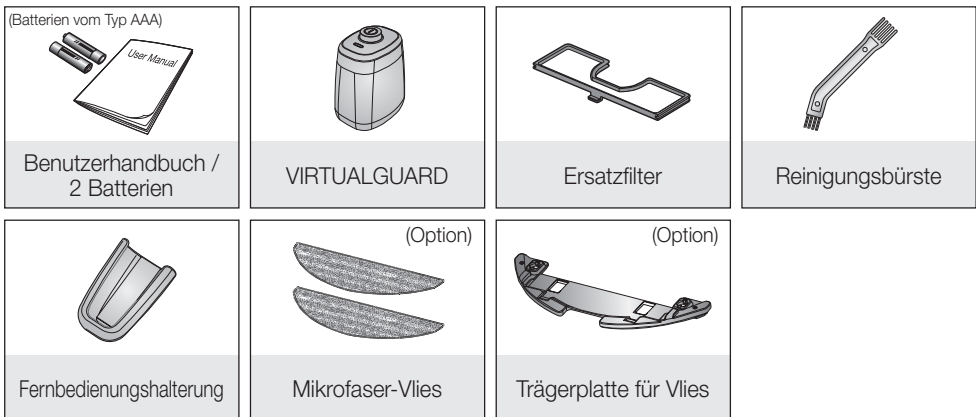

Inbetriebnahme des Robo-Saugers

BEZEICHNUNGEN DER TEILE

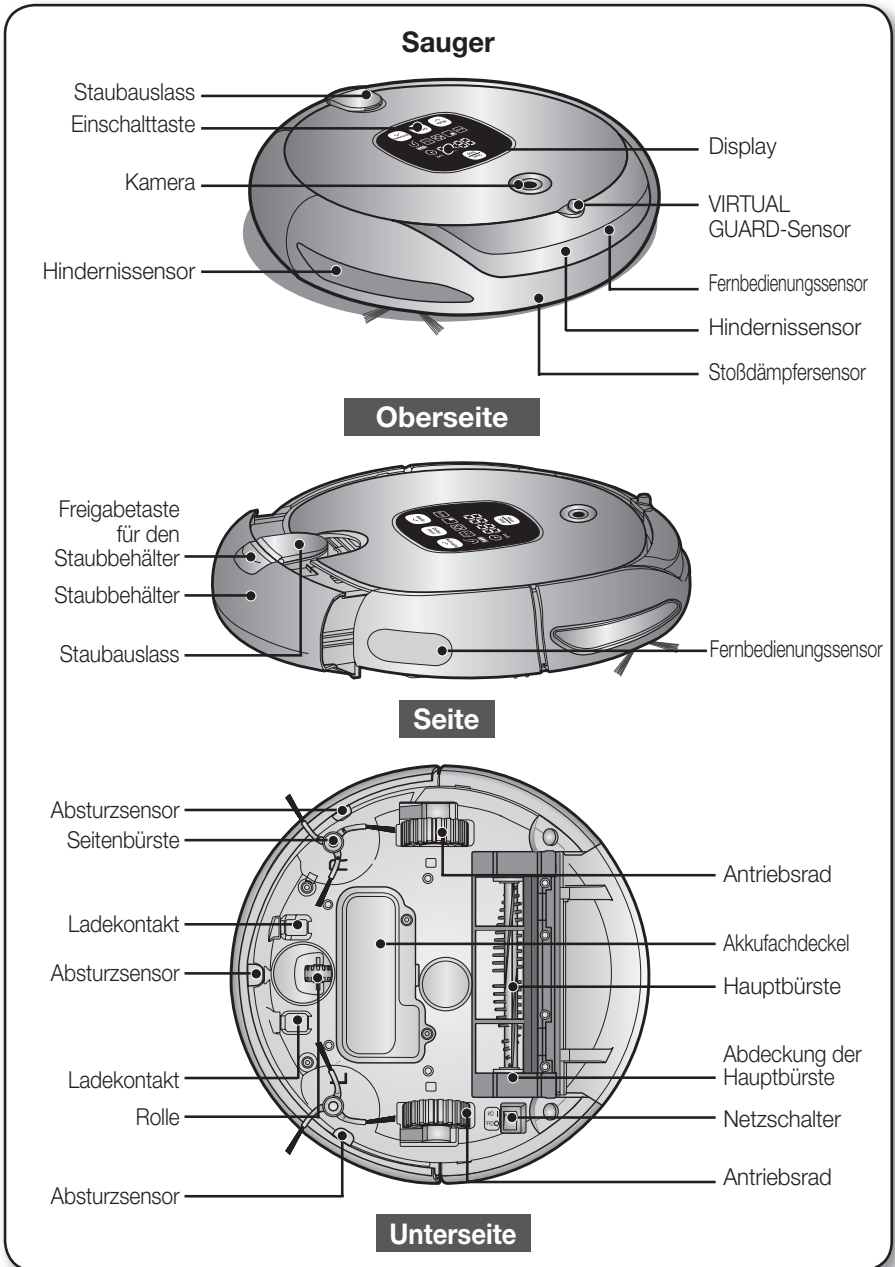

Inbetriebnahme des Robo-Saugers

BEZEICHNUNGEN DER TEILE

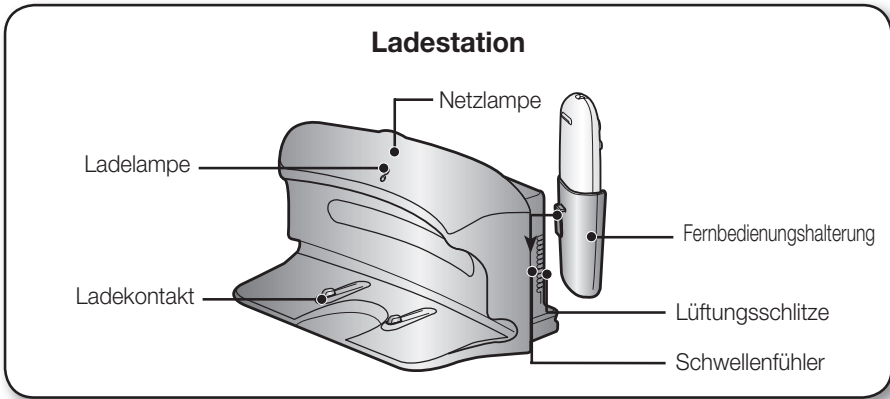

[VIRTUAL GUARD]

Labels: Modus-Anzeigelampe, Abstandserkennungssensor, Modus-/Netztaste, Sauger-Erkennungssensor.

■ **Einsetzen der Batterien**

Batterien sind nicht im Lieferumfang enthalten. Sie müssen zusätzlich erworben werden. Setzen Sie die Alkaline-Batterien (Typ D) vor Gebrauch ein.

- 1 Heben Sie die Abdeckung des VIRTUAL GUARDS an, während Sie die Verriegelungslasche herunterdrücken.
- 2 Setzen Sie die Batterien so in den VIRTUAL GUARD ein, wie in der nachfolgenden Abbildung gezeigt. (Wenn die Batterien mit falscher Polung eingesetzt werden, arbeitet der VIRTUAL GUARD nicht.)
- 3 Nachdem Sie die Spitze der Abdeckung in den Schlitz eingesetzt haben, drücken Sie das andere Ende, bis es hörbar einrastet.

* Technische Daten: Alkaline-Batterien Typ D (LR20)

Inbetriebnahme des Robo-Saugers

BEZEICHNUNGEN DER TEILE

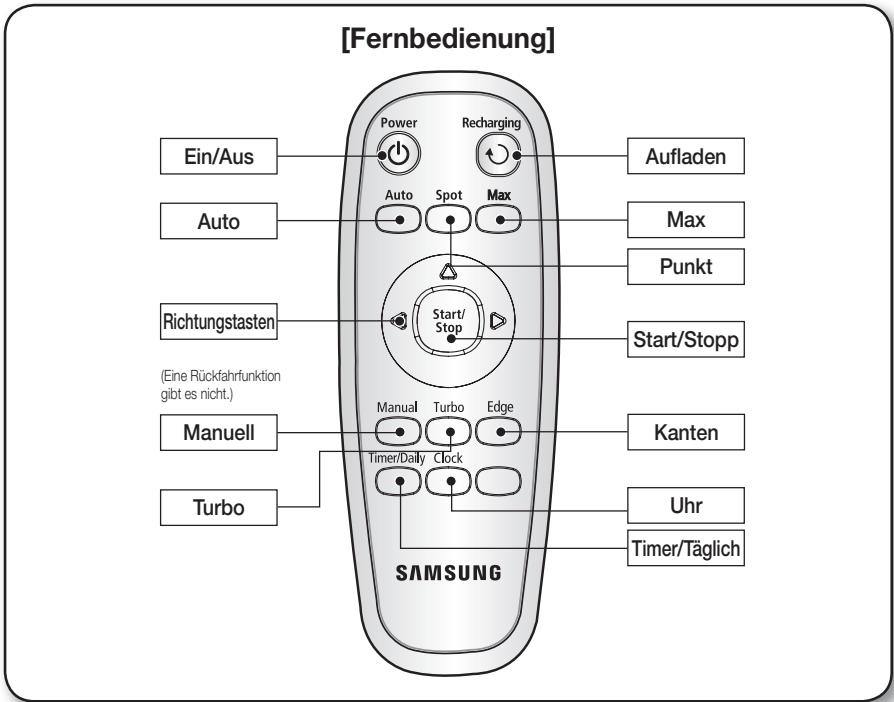

■ Einsetzen der Batterien fur die Fernbedienung

Die Fernbedienung wird beim Kauf ohne Batterien geliefert. Setzen Sie die Alkaline-Batterien (Typ AAA) vor Gebrauch ein.

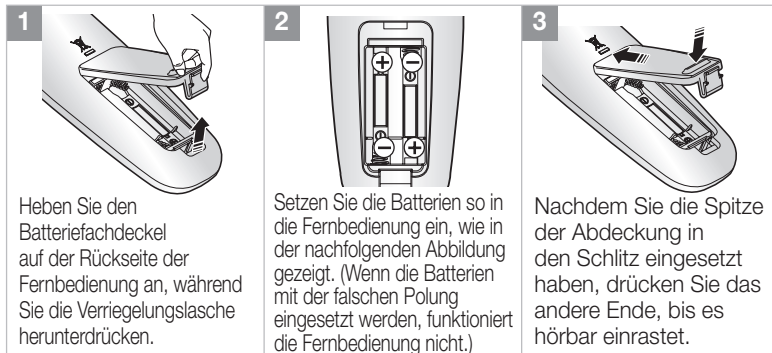

* Technische Daten: Alkaline-Batterien Typ AAA

Inbetriebnahme des Robo-Saugers

BEZEICHNUNGEN DER TEILE

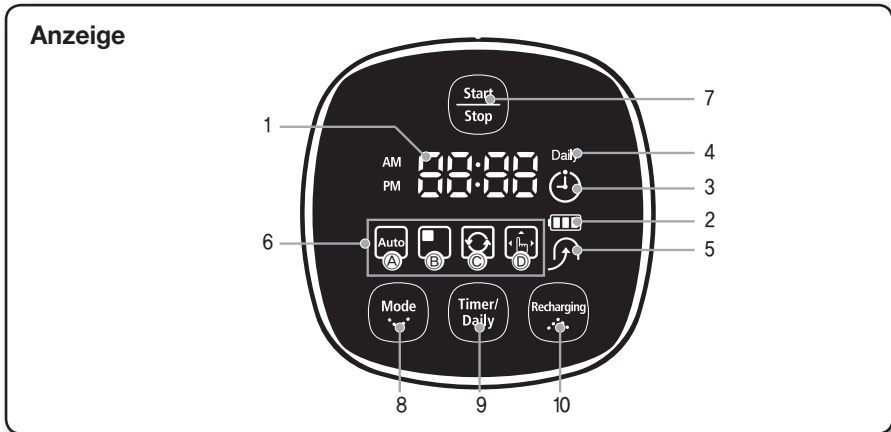

ANZEIGEBEREICH

1. Ziffernanzeige

- Zeigt den Timer, den Fortschritt und eventuelle Fehlercodes mit Hilfe von Ziffern, Buchstaben und Symbolen an.

2. Ladeanzeige

- Laden: Zeigt den Ladefortschritt in 3 Schritten an.

- Im Einsatz: Zeigt den Ladestand des Akkus an. Der Ladestand wird im Betrieb allmählich immer niedriger angezeigt.
(Wenn der Akku vollständig entladen ist, blinkt die Stufe und zeigt mit „LO“ an, dass nachgeladen werden muss.)

3. Startzeitvorwahl

- Wenn nach Zeitplan gesaugt werden soll, leuchtet das Symbol für die Startzeitvorwahl.

4. Täglich

- Wenn täglich gesaugt werden soll, leuchtet das Symbol für tägliches Saugen.

5. Aufladen

- Diese Symbol leuchtet auf, wenn der Robo-Sauger zur Ladestation zurückfährt, um seinen Akku aufzuladen.

6. Anzeige des Reinigungsmodus

- Bei jedem Drücken der Taste für den Reinigungsmodus wird der entsprechende Reinigungsmodus angezeigt.

(a) Automatikbetrieb: Dieses Symbol leuchtet, wenn Automatikbetrieb ausgewählt wird.

(b) Punktsaugen: Dieses Symbol leuchtet, wenn Punktsaugen ausgewählt wird.

(c) Maximalmodus: Dieses Symbol leuchtet, wenn der Maximalmodus ausgewählt wird.

(d) Manuelles Saugen: Dieses Symbol leuchtet, wenn manuelles Saugen ausgewählt wird.

TASTENBEREICH

7. Start/Stop

- Drücken Sie diese Taste, um den Saugbetrieb zu starten oder zu beenden.

8. Reinigungsmodus

- Drücken Sie diese Taste, um einen Reinigungsmodus auszuwählen. Nachdem Sie einen Reinigungsmodus gewählt haben, drücken Sie die Taste (), um mit dem Saugen zu beginnen.

9. Timer/Täglich

- Drücken Sie diese Taste, um das Saugen zeitlich zu planen.

10. Aufladen

- Wenn Sie diese Taste drücken, wird das Symbol „Aufladen“ eingeschaltet, und der Robo-Sauger kehrt zur Ladestation zurück, um seinen Akku aufzuladen.

Gebrauch des Robo-Saugers

ZUSAMMENSETZEN DES ROBO-SAUGERS

REIHENFOLGE BEI INBETRIEBNAHME

1. Gerät ein- und ausschalten

Um den Robo-Sauger zu verwenden, müssen Sie das Gerät mit dem Netzschalter unten am Sauger einschalten.

2. Installieren des Ladegeräts

Um den Robo-Sauger aufzuladen, müssen Sie zuerst das Ladegerät installieren.

3. Laden des Akkus

Der Akku ist beim Kauf entladen und sollte vor der ersten Gebrauch vollständig geladen werden.

4. Stellen der Uhrzeit

Sie müssen die Zeit einstellen, wenn Sie nach Plan (Startzeitvorwahl) oder täglich saugen möchten.

5. Einstellen des VIRTUAL GUARD

Sie können den Robo-Sauger mit dem Zaun-Modus (virtuelle Wand) auf einen bestimmten Bereich beschränken, oder mehrere Bereiche nacheinander reinigen, indem Sie den Wächter-Modus (virtuelle Tür) verwenden.

6. Befestigen des Mikrofaser-Vlieses

Befestigen Sie das Reinigungsvlies mit der Trägerplatte unten am Sauger.



EIN- UND AUSSCHALTEN DES GERÄTS

Um den Robo-Sauger zu verwenden, müssen Sie das Gerät mit dem Netzschalter einschalten. Wenn Sie den Netzschalter ausschalten, werden alle Einstellungen zurückgesetzt.

1. Drehen Sie das Gerät um und schalten Sie es mit dem Netzschalter ein.

- Wenn die Symbole nicht eingeschaltet werden, bedeutet dies, dass der Akku des Geräts leer ist. Um den Robo-Sauger in diesem Fall zu verwenden, müssen Sie das Gerät mit dem Netzschalter einschalten und es dann an die Ladestation andocken.
- Beachten Sie, dass alle Einstellungen zurückgesetzt werden, wenn Sie den Netzschalter ausschalten.

- * Wenn innerhalb von 5 Minuten nach dem Einschalten am Netzschalter keine Taste gedrückt wird, schaltet sich das Gerät automatisch ab, um ein Entladen des Akkus zu vermeiden. Zum erneuten Einschalten halten Sie die Taste Start/Stop am Gerät oder auf der Fernbedienung länger gedrückt.

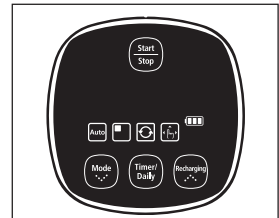
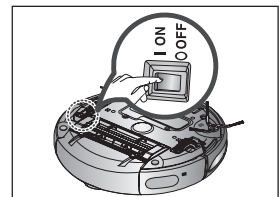

Wenn das Gerät am Netzschalter ausgeschaltet ist, wird der Robo-Sauger nicht geladen, selbst wenn er an die Ladestation angedockt ist.

Gebrauch des Robo-Saugers

ZUSAMMENSETZEN DES ROBO-SAUGERS

INSTALLIEREN DES LADEGERÄTS

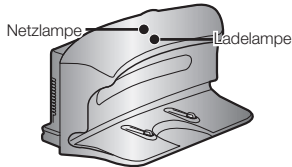

1. Stellen Sie das Ladegerät auf einer ebenen Fläche auf.

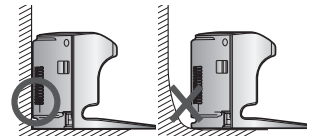

2. Es dürfen sich rechts und links im Abstand von 0,5 m und vorn im Abstand von 1 m keine Hindernisse befinden.

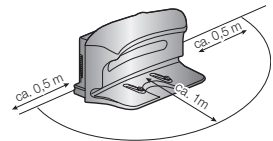

3. Stellen Sie das Ladegerät an einer Stelle auf, die für den Robo-Sauger gut zugänglich ist.



4. Verlegen Sie das Netzkabel an der Wand entlang.

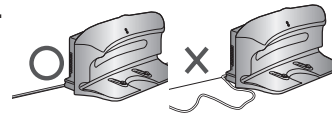

5. Wenn der Boden aus Holz besteht, stellen Sie das Ladegerät in Richtung der Holzmaserung auf.

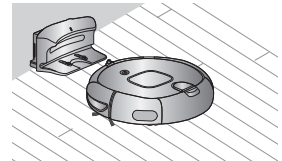

Lassen Sie den Netzstecker des Ladegeräts immer in der Steckdose.

- Wenn das Ladegerät nicht mit Strom versorgt wird, kann der Robo-Sauger das Ladegerät nicht finden und demnach auch nicht automatisch aufgeladen werden.
- Wenn der Robo-Sauger vom Ladegerät getrennt wird, wird der Akku automatisch entladen.

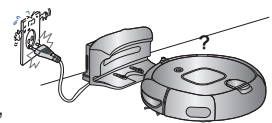

Gebrauch des Robo-Saugers

ZUSAMMENSETZEN DES ROBO-SAUGERS

LADEN

Wenn Sie das Gerät erwerben, ist der Akku vollständig entladen, und Sie müssen den Robo-Sauger manuell aufladen.

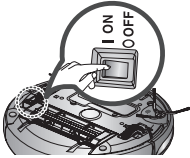

Schalten Sie das Gerät mit dem Netzschalter unten am Gerät ein.

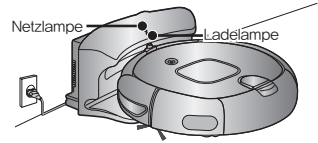

1. Nachdem Sie die Ladekontakte am Sauger mit dem den Ladekontakten der Ladestation ausgerichtet haben, justieren Sie das Gerät, bis das „Ladesignal“ ertönt.

- Die Ladelampe leuchtet grün.

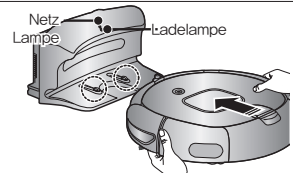

2. Überprüfen Sie den Ladezustand des Robo-Saugers.

- Wenn das Laden beginnt, werden im Display nacheinander die Ladeanzeige und „LO“ angezeigt.
- Wenn das Laden beendet ist, werden im Display nacheinander die Ladeanzeige und „FULL“ angezeigt.



Laden

Vollständig geladen

- Wenn die Ladeanzeige beim Saugen blinkt, beendet der Robo-Sauger das Reinigen und lädt sich automatisch am Ladegerät auf.
- Wenn die Ladeanzeige im Betrieb blinkt und es wird „LO“ angezeigt, kann der Robo-Sauger nicht mehr mit der Fernbedienung oder den Tasten am Sauger gesteuert werden. Tragen Sie den Robo-Sauger in diesem Fall zur Ladestation, um den Akku aufzuladen. (Dies passiert, wenn der Akku vollständig entladen ist.)

<Ladeanzeige>

Laden beendet Laden Aufladen erforderlich

HINWEIS

- Wenn Sie den Akku nach dem Kauf des Geräts erstmals laden, dauert es etwa 120 Minuten, den Akku vollständig aufzuladen, und diese Ladung reicht dann für etwa 90 Minuten.
- Die Ladezeit kann zunehmen, wenn Sie den Akku in überhitztem Zustand aufladen.
- Maßnahmen bei Störungen des Ladebetriebs.
Wenn der Robo-Sauger nicht automatisch geladen werden kann, überprüfen Sie Folgendes:
 - Schalten Sie die Stromversorgung mit dem Netzschalter unten am Robo-Sauger aus und wieder ein (zurücksetzen).
 - Trennen Sie den Netzstecker des Ladegeräts kurzzeitig vom Stromnetz (zurücksetzen).
 - Kontrollieren Sie, ob am Ladeanschluss Fremdstoffe vorhanden sind und wischen Sie die Ladekontakte am Sauger und dem Ladegerät mit einem trockenen Tuch ab.
 - Prüfen Sie, ob es in der Nähe des Ladegeräts Objekte gibt, die als starke Reflektoren wirken können.
- Wenn Sie den Robo-Sauger vom Ladegerät trennen, entlädt er sich auf natürliche Weise.
 - Laden Sie den Robo-Sauger mit dem Ladegerät, wenn dies möglich ist. (Wenn der Robo-Sauger längere Zeit nicht benutzt wird, schalten Sie die Stromversorgung des Robo-Saugers am Netzschalter aus und ziehen Sie das Netzkabel des Ladegeräts aus der Steckdose, um beide Geräte aufzubewahren.)

Gebrauch des Robo-Saugers

ZUSAMMENSETZEN DES ROBO-SAUGERS

INFORMATIONEN ZUM AKKU

- Der Robo-Sauger wird über einen umweltfreundlichen Nickelmetallhydrid-Akku (NiMH) mit Strom versorgt. Der Überladungsschutz garantiert eine lange Lebensdauer.
- **Die Garanzzeit für den Akku beträgt 6 Monate ab dem Kaufdatum.**
- Bevor Sie einen neuen Akku kaufen, fragen Sie das Kundendienstcenter nach dem Echtheitssymbol (SAMSUNG) und nach der Modellnummer.

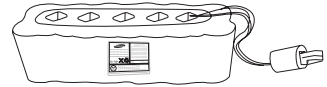

- Dieser Akku ist nur für Samsung Robo-Sauger bestimmt. Es ist strikt verboten, sie für andere Geräte oder andere Zwecke zu verwenden.
 - Bauen Sie den Akku nicht auseinander und manipulieren Sie ihn nicht.
 - Laden Sie ihn nur an gut belüfteten Stellen auf.
 - Bringen Sie den Akku nicht ins Feuer und erhitzen Sie ihn nicht.
 - Verbinden Sie die Pole ((+) oder (-)) des Akkus nicht mit Metallgegenständen.
 - Bewahren Sie ihn in geschlossenen Räumen auf (0°C~40°C).
 - Bevor Sie dieses Gerät wegwerfen, entsorgen Sie den Akku in umweltfreundlicher Weise.
 - Entsorgen Sie den Akku nicht zusammen mit Ihrem normalen Haushaltsmüll.
 - Befolgen Sie beim Entsorgen alter Akkus stets alle in Ihrem Land geltenden gesetzlichen Bestimmungen.
- * Wenn der Akku defekt ist, nehmen Sie ihn nicht auseinander. Wenden Sie sich an Ihr nächstgelegenes Kundendienstcenter.
- * Eine verlängerte Aufladezeit und eine kürzere Nutzungsdauer der Batterie zeigen das nahende Ende der Akkulebensdauer an. Wenden Sie sich an das offizielle den Kundendienst von Samsung Electronics, um den Akku ersetzen zu lassen.

Der in dieses Gerät eingebaute Akku kann vom Benutzer nicht ausgetauscht werden. Informationen zum Austausch erhalten Sie bei Ihrem Dienstleister.

Gebrauch des Robo-Saugers









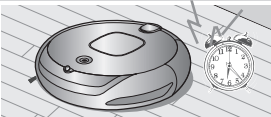

ZUSAMMENSETZEN DES ROBO-SAUGERS

EINSTELLEN DER UHRZEIT

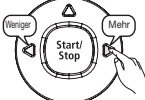
Sie müssen die Zeit einstellen, wenn Sie nach Plan (Startzeitvorwahl) oder täglich saugen möchten.

Sie können die Zeit nur mit Hilfe der Fernbedienung einstellen.

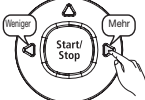
■ Sie können die Zeit nur mit Hilfe der Fernbedienung einstellen.

	Fernbedienung	Konfigurationsreihenfolge
 <p>Beispiel: Es ist gerade 07:00 Uhr.</p> 		<p>1 Eingeben der aktuellen Stunde.</p>
		<p>2 Starten des Konfigurationsmodus.</p>
		<p>3 Einstellen der Stunde.</p>
		<p>4 Eingeben der aktuellen Minute.</p>
		<p>5 Abschließen der Einstellungen</p>

- Um den Modus zum Einstellen der Zeit zu beenden, drücken Sie auf die Taste (Start/Stop) statt auf die Taste „Clock“.

- Wenn eine Reinigung geplant ist, können Sie die eingestellte Zeit nicht ändern.

Gebrauch des Robo-Saugers

ZUSAMMENSETZEN DES ROBO-SAUGERS

EINSTELLEN DES VIRTUAL GUARD

Sie können den Robo-Sauger mit dem Zaun-Modus (virtuelle Wand) auf einen bestimmten Bereich beschränken, oder mehrere Bereiche nacheinander reinigen, indem Sie den Wächter-Modus (virtuelle Tür) verwenden.

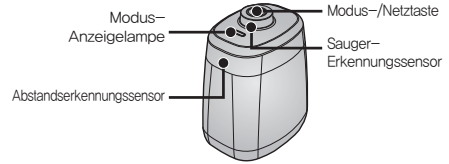

Bedienung der Tasten

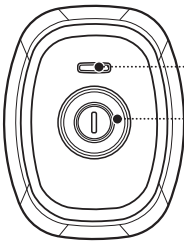

1. Anzeige der Moduslampe

- Zaunmodus (virtuelle Wand): Die rote Lampe blinkt.
- Wächtermodus (virtuelle Tür): Die grüne Lampe blinkt.
- Aus: Der VIRTUAL GUARD ist ausgeschaltet

2. Einstellen des Modus

- Bei jedem Drücken der Modus-/Netztaste wechselt das Gerät nacheinander zum Zaunmodus (virtuelle Wand) → Wächtermodus (virtuelle Tür) → Strom AUS.

* Der Abstand zur virtuellen Wand beträgt mindestens 2,5 m und kann je nach Umgebungsbedingungen und Bewegung des Roboters variieren.

Einstellen eines Zauns (virtuelle Wand)

Der VIRTUAL GUARD schafft eine unsichtbare Barriere, die der Robo-Sauger nicht überqueren kann, z. B. vor Blumentöpfen, Möbeln, der Haustür usw.

1. Wählen Sie mit der Modus-/Netztaste den Zaunmodus (virtuelle Wand).

- Die Moduslampe blinkt rot.

2. Installieren Sie den VIRTUAL GUARD vor der Fläche, zu der Sie dem Robo-Sauger den Zugang sperren möchten.

- Installieren Sie den VIRTUAL GUARD, damit der Abstandserkennungssensor eine unsichtbare Barriere schafft, die der Robo-Sauger nicht überqueren kann.

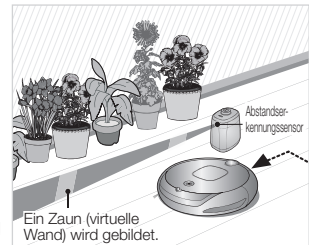

Gebrauch des Robo-Saugers

Verwenden des Wächtermodus (virtuelle Tür)

Der VIRTUAL GUARD erzeugt eine unsichtbare Tür, durch die der Robo-Sauger erst fahren kann, wenn der aktuelle Raum komplett gesaugt wurde. Der VIRTUAL GUARD öffnet die unsichtbare Tür, wenn das Zimmer vollständig gesaugt wurde.

1. Wählen Sie mit der Modus-/Netztaaste den Wächtermodus (virtuelle Tür).

- Die Moduslampe blinkt grün.

2. Installieren Sie den VIRTUAL GUARD am Eingang zum Zimmer, das sauber gemacht werden soll.

- Installieren Sie den VIRTUAL GUARD, damit der Abstandssensor eine unsichtbare Barriere schafft, die der Robo-Sauger nicht überqueren kann.

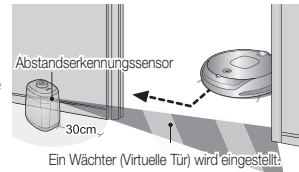
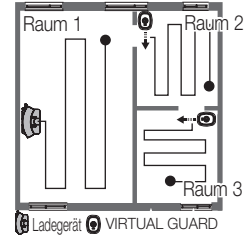

- Wenn Sie den VIRTUAL GUARD nicht verwenden, schalten Sie ihn aus. (Wenn Sie den Robo-Sauger längere Zeit nicht verwenden, nehmen Sie die Batterien heraus, damit sie nicht entladen werden.)
- Wenn die Modus-/Netztaaste nicht funktioniert, zeigt dies an, dass die Batterien abgenutzt sind. Ersetzen Sie in diesem Fall die Batterien. (Technische Daten: Alkaline-Batterien Typ D (LR20))
- Einen zusätzlichen VIRTUAL GUARD können Sie im Kundendienstcenter von Samsung Electronics erwerben.

- * Da eine unsichtbare Barriere gebildet wird, damit der Robo-Sauger nicht gegen den VIRTUAL GUARD fährt, wird empfohlen, den virtuellen Wächter in einem Abstand von 30 cm zu den Außenwänden zu installieren.



Informationen zum IrDA-Sensor

- Informationen zum IrDA-Sensor
- Die Übertragung der Infrarotsignale erfolgt möglicherweise im Freien oder an solchen Stellen nicht störungsfrei, wo Halogenlampen eingesetzt werden.
- Der Robo-Sauger verwendet 3 Arten von Infrarotgeräten, die möglicherweise vor einem anderen Gerät mit einer höheren Priorität nicht funktionieren.
- Beim Steuern des Robo-Saugers mit der Fernbedienung kann es passieren, dass der Robo-Sauger den virtuellen Zaun des VIRTUAL GUARD überquert und gegen ein Hindernis fährt, weil das Fernbedienungssignal eine höhere Priorität als das Signal des virtuellen Wächters hat.
- Wenn Sie den Robo-Sauger in einem kleinen Raum oder auf kurze Distanz steuern, kann es aufgrund von Interferenzen der Infrarotsignale zu Störungen kommen.
- Installieren Sie den VIRTUAL GUARD nicht in der Nähe des Ladegeräts, da der automatische Ladevorgang unterbrochen werden kann, wenn der virtuelle Wächter sich nahe beim Ladegerät befindet.
- Wenn Sie mehrere Robo-Sauger gleichzeitig verwenden, kann es aufgrund von Interferenzen der Infrarotsignale zu Störungen kommen.

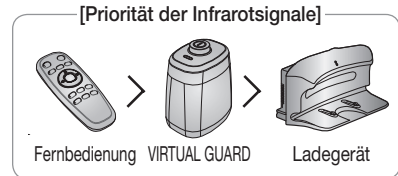

Gebrauch des Robo-Saugers

VERWENDEN DES ROBO-SAUGERS

BEFESTIGEN DES MIKROFASER-VLIESES (OPTION)

Mit dem Mikrofaser-Reinigungsvlies können Sie effektiv Staub entfernen.

Befestigen des Vlieses

1. Befestigen Sie das Mikrofaser-Vlies am Klettband der Trägerplatte für das Vlies.

- Richten Sie das Vlies genau auf dem Befestigungsstreifen der Trägerplatte aus - siehe Abbildung.

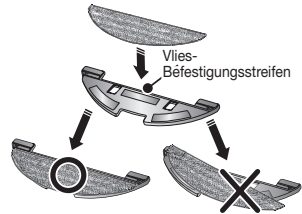

* Beim Befestigen darauf achten, dass das Vlies genau am Befestigungsstreifen ausgerichtet ist.

2. Dann richten Sie die Aussparungen der Trägerplatte mit den entsprechenden Elementen unten am Sauger aus und drücken darauf, bis die Platte mit einem Klickgeräusch einrastet.

- Wenn die Trägerplatte nicht richtig befestigt wird, kann sie sich bei der Reinigung lösen.

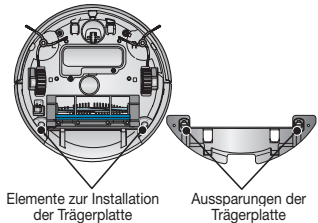

3. Positionieren Sie die Trägerplatte mit dem Vlies auf dem Boden und drücken sie nach unten.



- Da sich der Robo-Sauger mit Trägerplatte und Vlies nicht über Teppich bewegen kann, müssen Sie diese Teile vom Sauger abnehmen, bevor Sie einen Teppich mit dem Sauger reinigen.
- Reinigen Sie das verschmutzte Vlies nach der Verwendung.
- Lassen Sie das Vlies vollständig trocknen, bevor Sie es wieder verwenden. (Sie können das Vlies nicht nass verwenden.)
- Verwenden Sie das Vlies nicht zum Reinigen, wenn sich Flüssigkeiten wie z. B. Kaffee auf dem Boden befindet, andernfalls kann der Boden breitflächiger durch die Flüssigkeit verschmutzt werden.

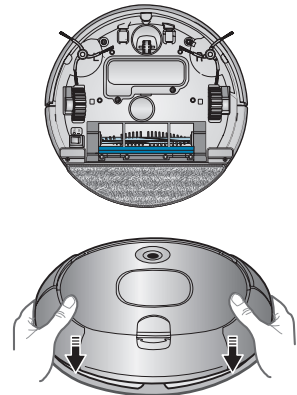

Gebrauch des Robo-Saugers

VERWENDEN DES ROBO-SAUGERS

STARTEN/STOPPEN DES STAUBSAUGERS

Sie können alle Funktionen des Robo-Saugers starten oder anhalten.

- Die Funktionen des Robo-Saugers stehen nur zur Verfügung, nachdem das Gerät mit dem Netzschalter eingeschaltet wurde.
- Wenn der Robo-Sauger läuft, drücken Sie die Taste , um den Betrieb zu unterbrechen und eine Funktion zu wählen.

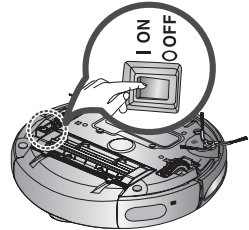

Gerät ein- und ausschalten

Einschalten

- Fernbedienung: Drücken Sie die Taste **[Power]**.
- Sauger: Drücken Sie die Taste .

Ausschalten

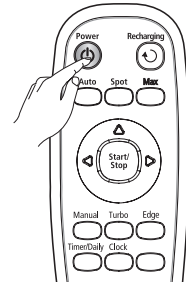

- Fernbedienung: Drücken Sie die Taste **[Power]**.
- Sauger: Halten Sie die Taste  3 Sekunden lang gedrückt.



Verwenden der Fernbedienung

Starten/Stoppen des Staubsaugers

Starten

- Fernbedienung: Drücken Sie die Taste Auto, Spot, Max oder Manual.
- Sauger : Drücken Sie nacheinander die Tasten  und , um Auto, Punkt, Maximal, oder Manuell auszuwählen.
 - * Wenn Sie die Taste  drücken, ohne einen Reinigungsmodus zu wählen, beginnt der Robo-Sauger im Automatikmodus.

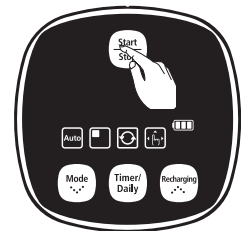

Anhalten

- Um den Robo-Sauger anzuhalten, drücken Sie die Taste  auf der Fernbedienung oder am Sauger.
- Wenn das Saugen beendet ist, wird der Robo-Sauger angehalten.

Gebrauch des Robo-Saugers

VERWENDEN DES ROBO-SAUGERS

AUFLADEN

Durch Drücken der Ladetaste können Sie den Robo-Sauger zum Ladegerät zurückkehren lassen, um den Akku aufzuladen.

- Wenn der Robo-Sauger läuft, drücken Sie die Taste (Start/Stop), um den laufenden Betrieb zu unterbrechen. Drücken Sie dann die Ladetaste.

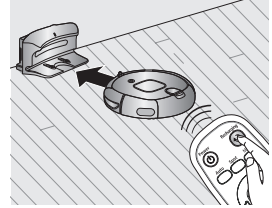

1. Drücken Sie die Ladetaste.

- Das Symbol (⏻) am Sauger wird eingeschaltet, und der Robo-Sauger kehrt zum Ladegerät zurück.

2. Um den Robo-Sauger anzuhalten, während er zum Ladegerät zurückkehrt, drücken Sie die Taste (Start/Stop).

3. Um die Ladefunktion zu testen, drücken Sie die Ladetaste, wenn sich der Robo-Sauger in weniger als 1,5m Entfernung vom Ladegerät befindet.

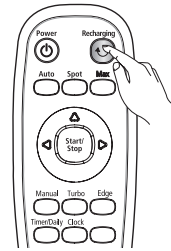

Verwenden der Fernbedienung

Fehlerbehebung, wenn der Robo-Sauger nicht zum Ladegerät zurückkehrt.

- Überprüfen Sie die Aufstellung des Ladegeräts
 - Befindet sich das Ladegerät an einer Stelle, von der aus es den Robo-Sauger nicht zum Ladegerät führen kann?
 - Befindet sich das Ladegerät an einer Stelle, die mehr als 5m vom Robo-Sauger entfernt ist?
: Es kann länger dauern, bis der Robo-Sauger zum Ladegerät zurückgekehrt ist.
- Laden Sie den Robo-Sauger in den folgenden Fällen manuell.
 - Das Ladegerät ist in einer Ecke aufgestellt.
 - Der Akku ist vollständig entladen.
 - Der Robo-Sauger wird durch ein Hindernis (Möbel usw.) aufgehalten.
 - Der Robo-Sauger kommt nicht über die Türschwelle hinweg und bis zum Aufstellort des Ladegeräts.

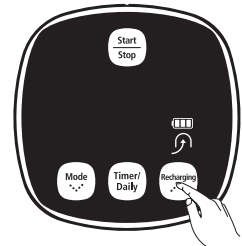

Verwenden der Tasten am Sauger

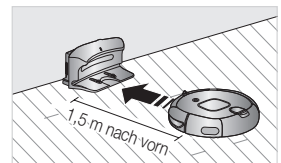

Gebrauch des Robo-Saugers

VERWENDEN DES ROBO-SAUGERS

AUTOMATISCHES SAUGEN

Der Robo-Sauger bewegt sich selbsttätig und säubert automatisch das Haus, bis der Saugvorgang abgeschlossen ist.

- Wenn der Saugvorgang gestartet wird, während der Robo-Sauger an die Ladestation angedockt ist, reduziert sich die Zeit für das Zurückfahren zum Ladegerät, da der Roboterstaubsauger seine ursprüngliche Position für die Rückfahrt speichert.
- Wenn die Akkuladung beim Saugen zu schwach wird, kehrt der Robo-Sauger automatisch zur Ladestation zurück, und setzt das Reinigen erst wieder fort, nachdem der Akku wieder aufgeladen ist. (Anzahl der wieder aufgenommenen Reinigungsvorgänge: einer)

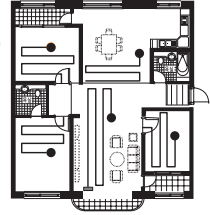

Tasten am Sauger	Taste der Fernbedienung	Konfigurationsreihenfolge
		1 Modus einstellen
		2 Modus beenden.

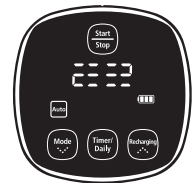

Normaler Modus

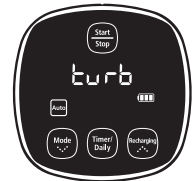

Turbomodus



Kantenmodus



Reinigung abgeschlossen

HINWEIS Informationen zum Fortsetzen des Reinigens

- Wenn der Robo-Sauger feststellt, dass die Reinigung abgeschlossen ist, wird die Funktion zum Fortsetzen des Reinigens nicht ausgeführt.
- Wenn Sie eine Taste drücken oder den Robo-Sauger bewegen, während er geladen wird, geht der Robo-Sauger davon aus, dass das Reinigen abgeschlossen ist, und setzt das Reinigen nicht fort.
- Drücken Sie keine Tasten und bewegen Sie den Robo-Sauger nicht, während er reinigt. Andernfalls geht der Robo-Sauger davon aus, dass das Reinigen abgeschlossen ist, und beginnt das Reinigen wieder von vorn.
- Wenn Sie auf der Fernbedienung die Taste Turbo drücken, wird auf dem Display entweder "On turbo" (08 88 88 88) oder "OFF turbo" (0F 88 88 88) angezeigt. Wenn "On turbo" (08 88 88 88) angezeigt wird, können Sie den Boden im Turbomodus reinigen.
- Wenn Sie auf der Fernbedienung die Taste Edge drücken, wird auf dem Display entweder "On Edge" (0n Ed 9E) oder "OFF Edge" (0F Ed 9E) angezeigt. Wenn "On Edge" (0n Ed 9E) angezeigt wird, können Sie den Boden im Kantenmodus reinigen.
- Wenn Sie sowohl den Turbomodus als auch den Kantenmodus aktivieren, wird auf dem Display abwechselnd (88 88 88 88 → Ed 9E) angezeigt.



Gebrauch des Robo-Saugers

VERWENDEN DES ROBO-SAUGERS

PUNKTUELLES SAUGEN

Sie können ganz einfach einen bestimmten Bereich reinigen, in dem sich z. B. viele Krümel, Staub usw. befinden.

- Bewegen Sie den Robo-Sauger an die Stelle, wo die punktuelle Reinigung durchgeführt werden soll.

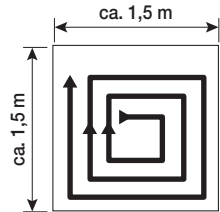

Tasten am Sauger	Taste der Fernbedienung	Konfigurationsreihenfolge
		1 Modus einstellen
		2 Modus beenden.

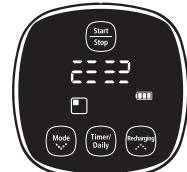

Normaler Modus

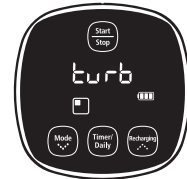

Turbomodus



Kantenmodus

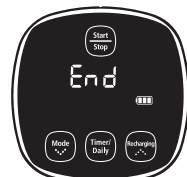

Reinigung abgeschlossen

- Im Punktreinigungsmodus säubert der Robo-Sauger einen Bereich mit einer Länge und Breite von 1,5 m.
- Wenn das Saugen beendet ist, zeigt der Robo-Sauger Ende, Stopp und Standby an.

HINWEIS Wenn der Robo-Sauger an die Ladestation angedockt ist, kann eine punktuelle Reinigung nicht durchgeführt werden.



- Wenn Sie auf der Fernbedienung die Taste Turbo drücken, wird auf dem Display entweder "On turbo" (On turbo) oder "OFF turbo" (Off turbo) angezeigt. Wenn "On turbo" angezeigt wird, können Sie den Boden im Turbomodus reinigen.
- Wenn Sie auf der Fernbedienung die Taste Edge drücken, wird auf dem Display entweder "On Edge" (On Edge) oder "OFF Edge" (Off Edge) angezeigt. Wenn "On Edge" angezeigt wird, können Sie den Boden im Kantenmodus reinigen.
- Wenn Sie sowohl den Turbomodus als auch den Kantenmodus aktivieren, wird auf dem Display abwechselnd (On turbo → On Edge) angezeigt.

Gebrauch des Robo-Saugers

VERWENDEN DES ROBO-SAUGERS

MAXIMALSAUGEN

Der Robo-Sauger bewegt sich automatisch und macht sauber, bis der Akku fast leer ist und nur noch eine Ladestufe angezeigt wird (blinkt).

- Wenn der Saugvorgang gestartet wird, während der Robo-Sauger an die Ladestation angedockt ist, reduziert sich die Zeit für das Zurückfahren zum Ladegerät, da der Robo-Sauger seine ursprüngliche Position für die Rückfahrt speichert.
- Wenn die Akkuladung beim Saugen zu schwach wird, kehrt der Robo-Sauger automatisch zur Ladestation zurück, und setzt das Reinigen erst wieder fort, wenn der Akku wieder aufgeladen ist. (Anzahl der fortgesetzten Reinigungsvorgänge: einer)

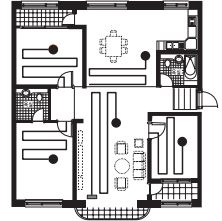

Tasten am Sauger	Taste der Fernbedienung	Konfigurationsreihenfolge
		1 Modus einstellen
		2 Modus beenden.

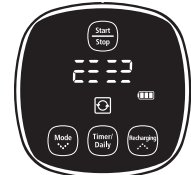

Normaler Modus

Informationen zum Fortsetzen des Reinigens

HINWEIS

- Wenn der Robo-Sauger feststellt, dass die Reinigung abgeschlossen ist, wird die Funktion zum Fortsetzen des Reinigens nicht ausgeführt.
- Wenn Sie eine Taste drücken oder den Robo-Sauger bewegen, während er geladen wird, geht der Robo-Sauger davon aus, dass das Reinigen abgeschlossen ist, und setzt das Reinigen nicht fort.

VORSICHT

- Drücken Sie keine Tasten und bewegen Sie den Robo-Sauger nicht, während er reinigt. Andernfalls geht der Robo-Sauger davon aus, dass das Reinigen abgeschlossen ist, und beginnt das Reinigen wieder von vorn.
- Wenn Sie auf der Fernbedienung die Taste Turbo drücken, wird auf dem Display entweder "On turbo" (ON ED 9E) oder "OFF turbo" (OF EB ED 9E) angezeigt. Wenn "On turbo (ON ED 9E)" angezeigt wird, können Sie den Boden im Turbomodus reinigen.
- Wenn Sie auf der Fernbedienung die Taste Edge drücken, wird auf dem Display entweder "On Edge" (ON ED 9E) oder "OFF Edge" (OF EB ED 9E) angezeigt. Wenn "On Edge (ON ED 9E)" angezeigt wird, können Sie den Boden im Kantenmodus reinigen.
- Wenn Sie sowohl den Turbomodus als auch den Kantenmodus aktivieren, wird auf dem Display abwechselnd (EB 9E → ED 9E) angezeigt.



Turbomodus



Kantenmodus

Gebrauch des Robo-Saugers

VERWENDEN DES ROBO-SAUGERS

MANUELLES SAUGEN

Sie können den Robo-Sauger mit der Fernbedienung selbst steuern, um eine bestimmte Stelle zu reinigen.

- Steuern Sie den Robo-Sauger an die Stelle, wo die manuelle Reinigung durchgeführt werden soll.
- Sie können die manuelle Reinigung mit Hilfe der Fernbedienung durchführen.

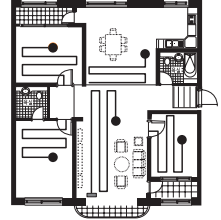

Tasten am Sauger	Taste der Fernbedienung	Konfigurationsreihenfolge
		1 Modus einstellen
		2 Modus beenden.



- Wenn der Robo-Sauger an die Ladestation angedockt ist, kann eine manuelle Reinigung nicht durchgeführt werden.



- Wenn Sie auf der Fernbedienung die Taste Turbo drücken, wird auf dem Display entweder "On turbo" (ON TURBO) oder "OFF turbo" (OFF TURBO) angezeigt. Wenn "On turbo" (ON TURBO) angezeigt wird, können Sie den Boden im Turbomodus reinigen.
- Wenn Sie auf der Fernbedienung die Taste Edge drücken, wird auf dem Display entweder "On Edge" (ON EDGE) oder "OFF Edge" (OFF EDGE) angezeigt. Wenn "On Edge" (ON EDGE) angezeigt wird, können Sie den Boden im Kantenmodus reinigen.
- Wenn Sie sowohl den Turbomodus als auch den Kantenmodus aktivieren, wird auf dem Display abwechselnd (TURBO-EDGE) angezeigt.

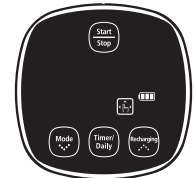

Normaler Modus

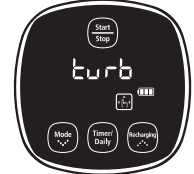

Turbomodus



Kantenmodus

Richtungstasten (vorwärts, links, rechts).
Eine Rückfahrfunktion gibt es nicht.

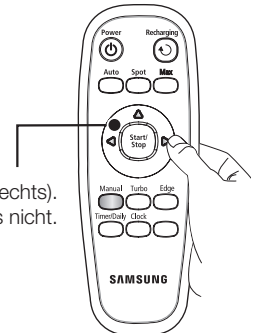

Gebrauch des Robo-Saugers

VERWENDEN DES ROBO-SAUGERS

STARTZEITVORWAHL

Sie können den Robo-Sauger so programmieren, dass er zu einer bestimmten Zeit zu arbeiten beginnt.

- Das Reinigen mit Startzeitvorwahl kann nur dann ausgeführt werden, wenn der Robo-Sauger an die Ladestation angedockt ist.

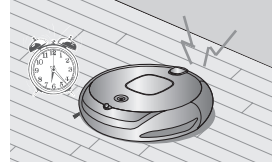

Tasten am Sauger	Taste der Fernbedienung	Konfigurationsreihenfolge	Beispiel: Aktuelle Zeit: 07:00 Uhr. Gewünschte Startzeit für das Reinigen: 09:30 Uhr.
		1 Starten des Modus für Startzeitvorwahl und bestätigen, dass die konfigurierte Zeit stimmt.	AM 07:00
		2 Einstellungen starten.	AM 07:
		3 Stunde einstellen	AM 09:
		4 Stunde bestätigen	AM 09:00
		5 Minuten einstellen.	AM 09:30
		6 Einstellungen abschließen.	AM 09:30
		Einstellungen abbrechen.	 Das Symbol geht aus.

Wenn das Gerät eingestellt ist, und Sie drücken auf die Taste (Start/Stop) statt auf die Taste Timer/Daily, wird der Modus für Startzeitvorwahl beendet.

Gebrauch des Robo-Saugers

VERWENDEN DES ROBO-SAUGERS

EINSTELLEN VON TÄGLICHEM REINIGEN

Sie können den Robo-Sauger so programmieren, dass er jeden Tag bei einer bestimmten Zeit zu arbeiten beginnt.

- Nur wenn der Robo-Sauger an die Ladestation angedockt ist, kann die tägliche Reinigung durchgeführt werden.

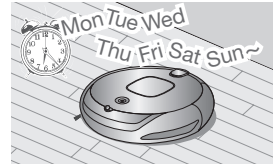

Tasten am Saugschlitten	Taste der Fernbedienung	Konfigurationsreihenfolge	Beispiel: Aktuelle Zeit: 07:00 Uhr. Gewünschte Startzeit für das Reinigen: 09:30 Uhr.
		1 Starten des Modus für tägliches Reinigen und bestätigen, dass die konfigurierte Zeit stimmt. (Prüfen Sie die eingestellte Zeit für die tägliche Reinigung).	
		2 Einstellungen starten.	
		3 Stunde einstellen	
		4 Stunde bestätigen	
		5 Minuten einstellen.	
		6 Einstellungen abschließen.	
		Einstellungen abbrechen.	Daily Das Symbol geht aus.

HINWEIS Wenn das Gerät eingestellt ist, und Sie drücken auf die Taste (Start/Stop) statt auf die Taste Timer/Daily, wird der Modus für das tägliche Reinigen beendet.

Gebrauch und Wartung des Zubehörs

VERWENDEN VON SPEZIALFUNKTIONEN

Die Spezialfunktionen machen die Verwendung des Robo-Saugers noch einfacher und bequemer.

- Die Spezialfunktionen werden über die Fernbedienung gesteuert.

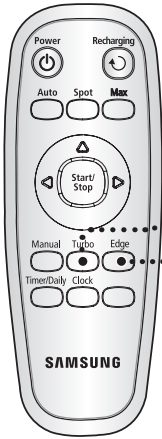

Turbomodus

Wenn Sie die Taste Turbo auf der Fernbedienung drücken, wird auf dem Display entweder "On turbo" (ON TURBO) oder "OFF turbo" (OFF TURBO) angezeigt.

On turbo (Turbomodus): Die Hauptbürste läuft mit maximaler Drehzahl.
Off turbo (normaler Modus): Die Hauptbürste läuft mit Standarddrehzahl.

Kantenmodus

Wenn Sie die Taste Edge auf der Fernbedienung drücken, wird auf dem Display entweder "On Edge" (ON EDGE) oder "OFF Edge" (OFF EDGE) angezeigt.

On Edge (Kantenmodus): Beim Reinigen werden Hindernisse berührt.
Off Edge (Ausweichmodus): Der Robo-Sauger umgeht Hindernisse beim Reinigen.

 Auch im Ausweichmodus "OFF EdGE" kann der Robo-Sauger an dünne oder dunkle Hindernisse stoßen.

HINWEIS

REINIGEN DES ROBO-SAUGERS

BEACHTEN SIE DIE REINIGUNGS- UND WARTUNGSHINWEISE

- Wenn der Netzschalter des Saugers beschädigt ist, wenden Sie sich an den Kundendienst von Samsung, damit keine Unfälle passieren.
- Benutzen Sie keine Hilfsmittel oder mechanischen Vorrichtungen, die nicht vom Hersteller installiert wurden.

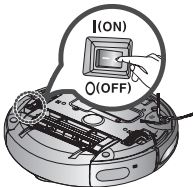

- Schalten Sie den Netzschalter unten am Sauger immer aus, ehe Sie den Robo-Sauger reinigen. Der Robo-Sauger könnte plötzlich angehen und eine Verletzung verursachen.



Gebrauch und Wartung des Zubehörs

REINIGEN DES SENSORFENSTERS UND DER KAMERA

Schalten Sie den Netzschalter unten am Sauger immer aus, ehe Sie den Robo-Sauger reinigen.

- Sprühen Sie niemals Wasser, Verdünner, Reinigungsbenzin usw. direkt auf den Sauger des Robo-Saugers.

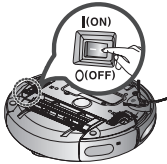

- Wischen Sie das Sensorfenster und die Kamera leicht mit einem weichen Tuch ab.

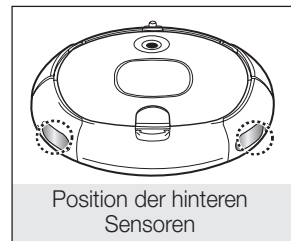
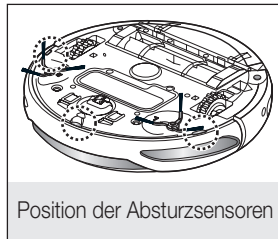
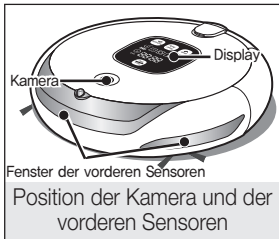

REINIGEN DES ROBO-SAUGERS

SCHNELLES ENTLLEEREN DES STAUBBEHÄLTERS

- Sie können den Staubbehälter mit Hilfe eines normalen Staubsaugers einfach leeren, ohne den Staubbehälter entnehmen zu müssen.

1. Öffnen Sie die Abdeckung des Staubauslasses.

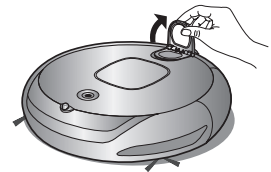

2. Wenn Sie die Saugdüse des Staubsaugers an den Staubauslass halten, saugt er den Staub direkt aus dem Staubbehälter heraus.

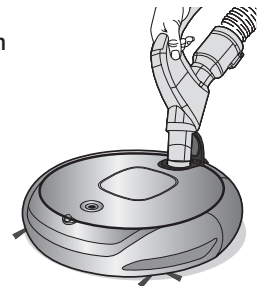

Gebrauch und Wartung des Zubehörs

REINIGEN DES STAUBBEHÄLTERS UND DES FILTERS

Entleeren Sie vor dem Reinigen den Staubbehälter.

- Wenn Sie den Staubbehälter herausnehmen, achten Sie sorgfältig darauf, den Staub aus dem Behälter nicht zu verschütten.
- Leeren Sie den Staubbehälter in folgenden Situationen:
 1. Staub hat sich im Staubbehälter angesammelt.
 2. Die Saugleistung geht plötzlich zurück.
 3. Der Lärm nimmt zu.

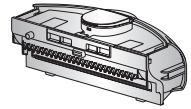

1. Drücken Sie die Freigabetaste für den Staubbehälter (PUSH) und ziehen Sie den Staubbehälter heraus.

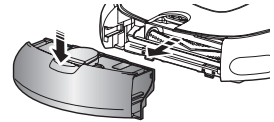

2. Öffnen Sie den Deckel des Staubbehälters, indem Sie ihn in Richtung des in der Abbildung dargestellten Pfeils ziehen.

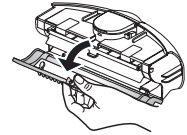

3. Lösen Sie den Filter vom Staubbehälter, indem Sie ihn in Richtung des in der Abbildung dargestellten Pfeils ziehen.

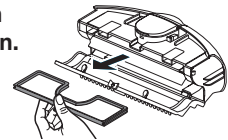

4. Wischen Sie den Staub von Filter und Staubbehälter ab.

* Sie können beide mit Wasser spülen.

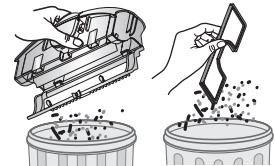

5. Setzen Sie den Filter wieder in den Staubbehälter ein.

- Vergewissern Sie sich, dass das Gitter des Filters nach unten zeigt. Es kann nicht in der falschen Richtung eingesetzt werden.

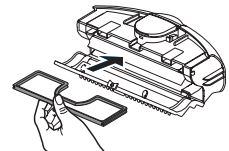

6. Schließen Sie den Deckel des Staubbehälters und setzen Sie ihn in den Sauger ein.

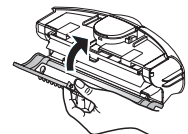

Gebrauch und Wartung des Zubehörs

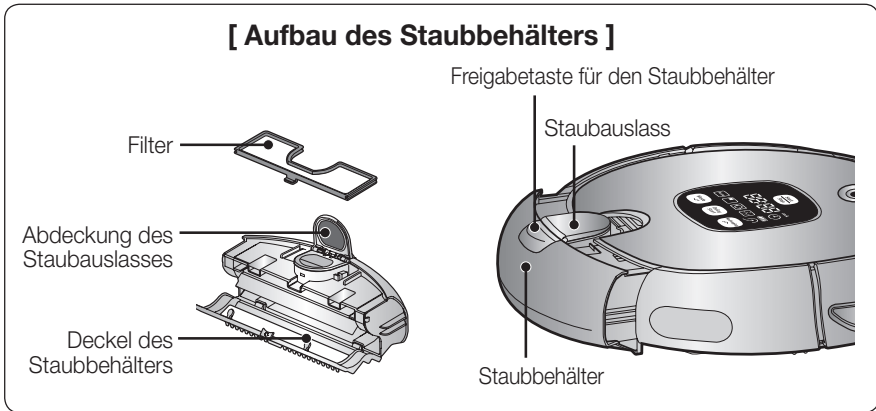

REINIGEN DES ROBO-SAUGERS

REINIGEN DER HAUPTBÜRSTE

Schalten Sie den Netzschalter unten am Sauger immer aus, ehe Sie den Robo-Sauger reinigen.



- Da der Staub aus dem Staubbehälter herausfallen kann, entfernen Sie den Staubbehälter, ehe Sie die Hauptbürste reinigen.

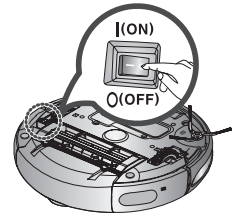

- 1. Drücken Sie die Freigabetaste für den Staubbehälter (PUSH), um den Staubbehälter zu lösen.**

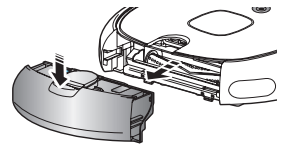

- 2. Nachdem Sie überprüft haben, ob Fremdstoffe vorhanden sind, drücken Sie den Haken, mit dem die Bürstenabdeckung fixiert wird, um die Abdeckung zu lösen.**

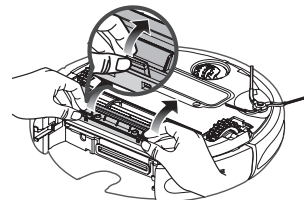

Gebrauch und Wartung des Zubehörs

REINIGEN DES ROBO-SAUGERS

3. Heben Sie die Hauptbürste aus dem Gerät.

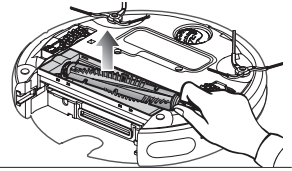

4. Entfernen Sie Fremdstoffe (z. B. lange Haare oder Fäden), die sich um die Saugbürste gewickelt haben, mit Hilfe einer Reinigungsbürste oder eines Staubsaugers.



5. Nach dem Reinigen setzen Sie die Hauptbürste zuerst auf der Seite des Netzschalters ein, und befestigen Sie dann die andere Seite der Bürste ebenso.

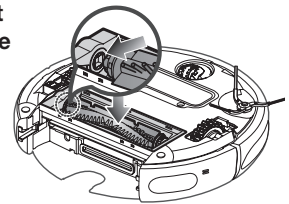

6. Nachdem Sie die 3 Spitzen oben an der Abdeckung eingesetzt haben, drücken Sie das andere Ende, bis es hörbar einrastet.

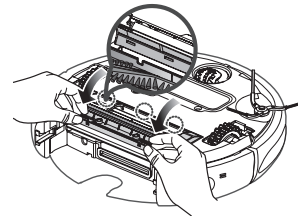

- Um zu verhindern, dass der Robo-Sauger verstopft, achten Sie darauf, keine Fremdkörper aufzusaugen.
- Wenn sich die Fremdstoffe nur mit Schwierigkeiten entfernen lassen, wenden Sie sich an ein Kundendienstcenter.
- Da die Saugbürste den Staub vom Boden aufnimmt, können sich lange Fäden oder Haare um die Bürste wickeln. Kontrollieren und reinigen Sie die Hauptbürste regelmäßig.

Gebrauch und Wartung des Zubehörs

REINIGEN DES ROBO-SAUGERS

REINIGEN DER ROTIERENDEN SEITENBÜRSTEN FÜR DIE KANTENREINIGUNG

Schalten Sie den Netzschalter unten am Sauger immer aus, ehe Sie den Robo-Sauger reinigen.

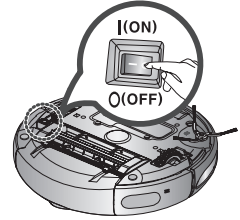

1. Kontrollieren Sie, ob die Seitenbürsten verbogen sind, oder ob Fremdstoffe an den Bürsten haften.

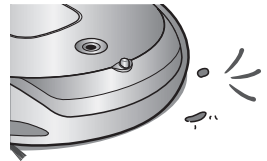

2. Ziehen Sie Gummihandschuhe an und wickeln Sie die Seitenbürsten in ein Tuch ein, das Sie vorher 10 Sekunden lang in heißes Wasser getaucht haben. Reinigen Sie die Bürsten vorsichtig mit dem Tuch.

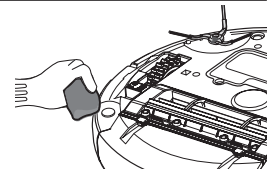

3. Drehen Sie die Seitenbürsten und wiederholen Sie den Vorgang aus Schritt 2.

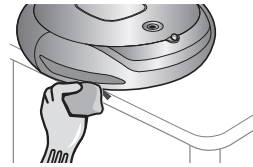

4. Wenn sich Haare oder Fäden zwischen dem Sauger und den Seitenbürsten verfangen haben, lösen Sie die Schrauben der Seitenbürsten mit Hilfe eines Kreuzschlitzschraubendrehers und ziehen Sie die Bürsten ab. Wenn Sie die Bürsten wieder einbauen, bringen Sie die L-Markierungen an der Seitenbürste und am Sauger übereinander und bauen Sie die Seitenbürste dann wieder ein. (Die rechte Seitenbürste ist mit dem Buchstaben "R" markiert.)

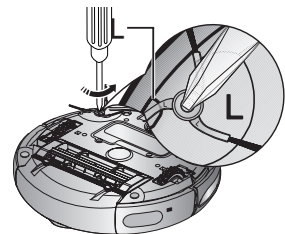

HINWEIS

Da die rotierenden Seitenbürsten leicht Haare und andere Fremdstoffe anziehen, reinigen Sie die Bürsten regelmäßig und in kurzem Abstand. Zu viele Fremdstoffe an den Seitenbürsten können die Bürsten beschädigen.

Gebrauch und Wartung des Zubehörs

REINIGEN DES ROBO-SAUGERS

REINIGEN DER ANTRIEBSRÄDER

Schalten Sie den Netzschalter unten am Sauger immer aus, ehe Sie den Robo-Sauger reinigen.

- Wenn der Robo-Sauger plötzlich im Zickzack zu fahren beginnt, kann es sein, dass Fremdstoffe an den Antriebsrädern haften.

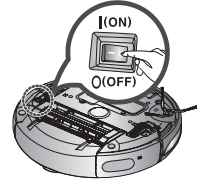

1. Zum Reinigen der Antriebsräder legen Sie ein weiches Tuch auf den Boden und drehen Sie den Sauger vorsichtig auf die Oberseite.

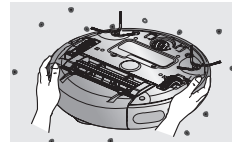

2. Kontrollieren Sie das Gerät auf Fremdstoffe und entfernen Sie diese mit Hilfe eines Stäbchens oder einer Pinzette mit stumpfen Zangen.

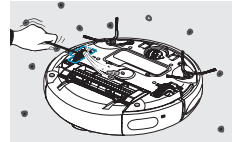

REINIGEN DES MIKROFASER-VLIESES (OPTION)

Ein verschmutztes Reinigungsvlies kann schlecht riechen, deshalb sollte das Vlies stets sauber gehalten werden.

1. Lösen Sie die Trägerplatte des Mikrofaservlieses von der Unterseite des Saugers.

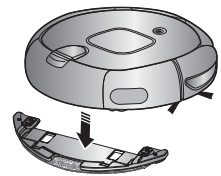

2. Lösen Sie das Vlies von der Trägerplatte.

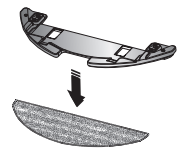

3. Reinigen Sie das Vlies in sauberem Wasser.



4. Lassen Sie das Mikrofaservlies an einem gut belüfteten Ort vollständig trocknen, bevor Sie es wieder verwenden.

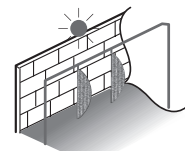

Fehlersuche

CHECKLISTE ZUR SELBSTHILFE

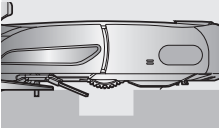
STÖRUNG	FRAGEN	MASSNAHMEN
<p>Der Robo-Sauger läuft überhaupt nicht.</p>	<ul style="list-style-type: none"> • Ist der Staubbehälter eingesetzt? • Ist der Netzschalter eingeschaltet? • Wird ein Reinigungsmodus (Auto) im Display angezeigt? • Blinkt in der Ladestandsanzeige nur eine Stufe und wird im Display 'LO' angezeigt? • Der Robo-Sauger läuft nicht, wenn die Batterie in der Fernbedienung erschöpft ist. 	<ul style="list-style-type: none"> • Setzen Sie den Staubbehälter ein? • Schalten Sie das Gerät am Netzschalter ein. • Drücken Sie die Taste (Auto). (Zum Ausschalten halten Sie die Taste (Auto) min. 3 Sekunden lang gedrückt.) • Heben Sie den Robo-Sauger hoch und docken Sie ihn manuell an das Ladegerät an, um ihn aufzuladen. • Ersetzen Sie die Batterien in der Fernbedienung. (Typ AAA)
<p>Der Robo-Sauger stellt plötzlich den Saugbetrieb ein.</p> 	<ul style="list-style-type: none"> • Blinkt in der Ladestandsanzeige nur eine Stufe und wird im Display 'LO' angezeigt? • Hat sich der Robo-Sauger in einem Kabel auf dem Boden verfangen? • Bleibt der Robo-Sauger an einer Bodenkante (Höhenunterschied) hängen? - Das Antriebsrad hat keinen Bodenkontakt. • Hat sich ein dünnes Tuch um das Antriebsrad gewickelt? • Steckt der Robo-Sauger an einer Türschwelle fest? 	<ul style="list-style-type: none"> • Heben Sie den Robo-Sauger hoch, und docken Sie ihn manuell an das Ladegerät an, um ihn aufzuladen. • Schalten Sie das Gerät am Netzschalter aus und entfernen Sie die Kabel. • Schalten Sie das Gerät am Netzschalter aus und bringen Sie den Robo-Sauger an eine andere Stelle, um sauber zu machen. • Schalten Sie das Gerät am Netzschalter aus und entfernen Sie das Tuch. • Schalten Sie das Gerät am Netzschalter aus und bringen Sie den Robo-Sauger an eine andere Stelle, um sauber zu machen.
<p>Die Saugleistung ist gering.</p>	<ul style="list-style-type: none"> • Prüfen Sie, ob der Staubbehälter voll ist. • Prüfen Sie, ob der Einlass durch Fremdstoffe blockiert wird. • Kontrollieren Sie, ob der Filter verstopft ist. 	<ul style="list-style-type: none"> • Halten Sie den Robo-Sauger an und leeren Sie den Staubbehälter. • Schalten Sie das Gerät aus und entfernen Sie die Fremdstoffe. • Säubern Sie gründlich den Filter.

Fehlersuche

CHECKLISTE ZUR SELBSTHILFE

SYMPTOM	FRAGEN	MASSNAHMEN
Der Robo-Sauger kann das Ladegerät nicht finden.	<ul style="list-style-type: none">• Prüfen Sie, ob das Netzkabel des Ladegeräts richtig mit der Steckdose verbunden ist.• Entfernen Sie Hindernisse innerhalb eines Bereichs von etwa 1 m vor dem Ladegerät und etwa 0,5 m nach links und rechts.• Wenn Fremdstoffe am Ladekontakt haften, wischen Sie diese ab mit einem trockenen Tuch ab.• Wurde der VIRTUAL GUARD in der Nähe des Ladegeräts installiert?	<ul style="list-style-type: none">• Bewegen Sie den VIRTUAL GUARD an eine andere Stelle, damit der Robo-Sauger automatisch aufladen kann.
Der Robo-Sauger kann den VIRTUAL GUARD passieren.	<ul style="list-style-type: none">• Sind die Batterien des VIRTUAL GUARD verbraucht?• Ist der VIRTUAL GUARD auf den Wächtermodus (virtuelle Tür) eingestellt?• Ist die Moduslampe ausgeschaltet?	<ul style="list-style-type: none">• Ersetzen Sie die Batterien. (2 Alkaline-Batterien Typ D (LR20))• Stellen Sie den VIRTUAL GUARD auf den Zaunmodus (virtuelle Wand) ein.• Überprüfen Sie, ob der VIRTUAL GUARD ausgeschaltet ist und stellen Sie den VIRTUAL GUARD dann in den gewünschten Modus.
Die Nutzungszeit der Batterien des VIRTUAL GUARD ist zu kurz.	<ul style="list-style-type: none">• Verwenden Sie Mangan-Trockenzellen?	<ul style="list-style-type: none">• Ersetzen Sie die Batterien durch neue. (2 Alkaline-Batterien Typ D (LR20))
Im Display erscheint ein Countdown ab der Zahl 30.	<ul style="list-style-type: none">• Wurde der Robo-Sauger vom Ladegerät entfernt oder während des Ladens gedrückt?	<ul style="list-style-type: none">• Wenn der Robo-Sauger beim Laden getrennt oder heruntergedrückt wird, kehrt er nach 30 Sekunden automatisch zum Ladegerät zurück.

Fehlersuche

FEHLERBEHEBUNG UND FEHLERCODES



FEHLERCODE	URSACHE	LÖSUNG
C 00	<ul style="list-style-type: none"> Der Robo-Sauger hat sich beim Fahren verfangen, verklemmt oder hängt fest. 	<ul style="list-style-type: none"> Schalten Sie das Gerät am Netzschalter unten am Sauger aus und bringen Sie den Robo-Sauger an eine andere Stelle.
C 01	<ul style="list-style-type: none"> Fremdstoffe (Schnur, Papier, Spielzeug usw.) sind in der Hauptbürste gefangen. 	<ul style="list-style-type: none"> Schalten Sie das Gerät am Netzschalter unten am Sauger aus und entfernen Sie die Fremdstoffe von der Hauptbürste.
C 02	<ul style="list-style-type: none"> Fremdstoffe (Schnur, Papier, Spielzeug usw.) sind im linken Antriebsrad gefangen. 	<ul style="list-style-type: none"> Schalten Sie das Gerät am Netzschalter unten am Sauger aus und entfernen Sie die Fremdstoffe vom linken Antriebsrad.
C 03	<ul style="list-style-type: none"> Fremdstoffe (Schnur, Papier, Spielzeug usw.) sind im rechten Antriebsrad gefangen. 	<ul style="list-style-type: none"> Schalten Sie das Gerät am Netzschalter unten am Sauger aus und entfernen Sie die Fremdstoffe vom rechten Antriebsrad.
C 05	<ul style="list-style-type: none"> Überprüfen Sie den Stoßdämpfersensor. 	<ul style="list-style-type: none"> Ziehen Sie den festgeklemmten Stoßdämpfersensor leicht heraus.
C 06	<ul style="list-style-type: none"> Fremdstoffe (Schnur, Papier, Spielzeug usw.) haften auf dem Fenster eines Hindernissensors. 	<ul style="list-style-type: none"> Schalten Sie das Gerät am Netzschalter unten am Sauger aus und wischen Sie die Fremdstoffe mit einem weichen Tuch von den vorderen und hinteren Sensorfenstern ab.
C 07	<ul style="list-style-type: none"> Fremdstoffe (Schnur, Papier, Spielzeug usw.) haften auf dem Fenster eines Absturzsensors. 	<ul style="list-style-type: none"> Schalten Sie das Gerät am Netzschalter unten am Sauger aus und wischen Sie die Fremdstoffe mit einem weichen Tuch von den Fenstern der Absturzsensoren ab.
C 08	<ul style="list-style-type: none"> Der Staubbehälter ist nicht eingesetzt 	<ul style="list-style-type: none"> Setzen Sie den Staubbehälter so ein, dass er hörbar einrastet.
C 09	<ul style="list-style-type: none"> Fremdkörper haben sich in den rotierenden Seitenbürsten verfangen. 	<ul style="list-style-type: none"> Schalten Sie das Gerät am Netzschalter unten am Sauger aus und entfernen Sie die Fremdkörper.

* Wenn Sie die Start/Stop-Taste drücken oder den Netzschalter betätigen, wird der Fehlercode gelöscht.

Technische Daten

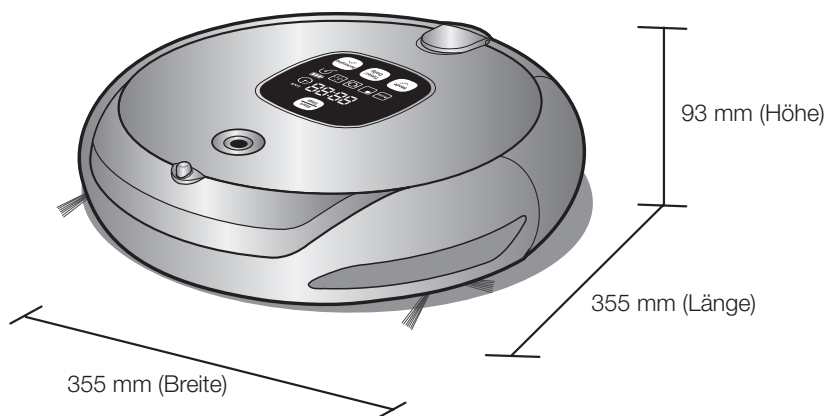

Sauger

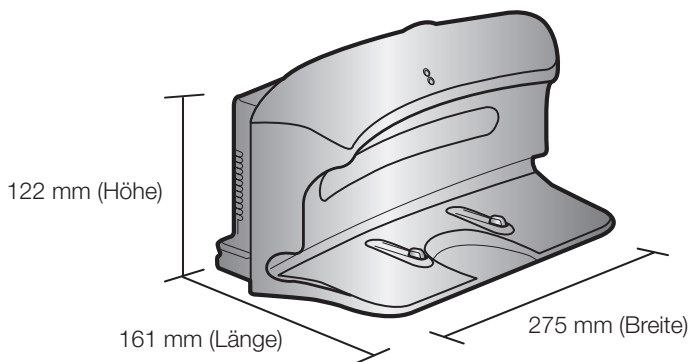

Ladestation

Technische Daten

KLASSIFIKATION	ANGABE	DATEN
Technische Daten - Mechanisch	Durchmesser	355 mm
	Höhe	93 mm
	Gewicht	4,0 kg
Technische Daten - Elektrisch	Netzspannung	AC 220-240V~, 50-60Hz
	Leistungsaufnahme der Ladestation	50 W
	Leistungsaufnahme des Saugers	40 W
	Akku	14,4 V / 2.000 mA
Technische Daten - Reinigung	Kapazität des Staubbehälters	Etwa 0,6 l
	Ladeverfahren	Automatisch / Manuell Laden
	Reinigungsmodus	Automatisch, Punktuell, Maximal, Manuell, Startzeitvorwahl, täglich Reinigen
	Ladezeit	Etwa 120 Minuten
	Reinigungsdauer (auf hartem Untergrund)	Etwa 90 Minuten
Reinigungsmethode		Deckenformerkenung
Steuerung am Saugers		Touch-Tasten

Dieses Gerät erfüllt die nachfolgenden
Richtlinien: EMV-Richtlinie 2004/108/EG
Niederspannungsrichtlinie 2006/95/EG



Falls Sie Fragen oder Anregungen zu Samsung-Produkten haben,
wenden Sie sich bitte an den Samsung-Kundendienst.

01805 - SAMSUNG(726-7864 € 0,14/Min)

www.samsung.com



SR8894
SR8895

Robotic Vacuum Cleaner User Manual

**Planet
First** 100%
Recycled Paper

This manual is made with 100% recycled paper.

- * Before operating this unit, please read the instructions carefully.
- * For indoor use only.

English

imagine the possibilities

Thank you for purchasing a Samsung product.
To receive a more complete service,
please register your product at
www.samsung.com/register

SAMSUNG

Safety information

SAFETY INFORMATION



- Before operating the appliance, please read this manual thoroughly and retain it for your reference.



- Because these following operating instructions cover various models, the characteristics of your vacuum cleaner may differ slightly from those described in this manual.

CAUTION/WARNING SYMBOLS USED



Indicates that a danger of death or serious injury exists.



Indicates that a risk of personal injury or material damage exists.

OTHER SYMBOLS USED



Explains terms to help users understand how use the product properly.

Safety information

IMPORTANT SAFETY INSTRUCTIONS

When using an electrical appliance, basic precautions should be observed, including the following:

READ ALL INSTRUCTIONS BEFORE USING YOUR ROBOTIC VACUUM CLEANER.

Unplug from outlet when not in use and before conducting maintenance.

WARNING: to reduce the risk of fire, electric shock, or injury:

GENERAL

- Use only as described in this manual.
- Do not operate the robotic vacuum cleaner or charger if it has been damaged in any way.
- If the cleaner is not working as it should, has been dropped, damaged, left outdoors, or dropped in water, return it to a customer care center.
- Do not handle the charger or robotic vacuum cleaner with wet hands.
- Use only on dry, indoor surfaces.
- This appliance is not intended for use by persons (including children) with reduced physical, sensory or mental capabilities, or lack of experience and knowledge, unless they have been given supervision or instruction concerning use of the appliance by a person responsible for their safety.
- Children should be supervised to ensure that they do not play with the appliance.

BATTERY CHARGER

- Do not modify the polarized plug to fit a non-polarized outlet or extension cord.
- Do not use outdoors or on wet surfaces.
- Unplug the charger from the outlet when not in use and before servicing.
- Use only the charger supplied by the manufacturer to recharge.
- Do not use with a damaged cord or plug.
- Do not pull or carry by the cord, use the cord as a handle, close the door on the cord, or pull the cord around sharp edges or corners. Keep the cord away from heated surfaces.
- Do not use extension cords or outlets with inadequate current carrying capacity.
- Do not unplug by pulling on the cord. To unplug, grasp the plug, not the cord.
- Do not mutilate or incinerate batteries as they will explode at high temperatures.
- Do not attempt to open the charger. Repairs should only be carried out by a qualified customer care centre.
- Do not expose the charger to high temperatures or allow moisture or humidity of any kind to come into contact with the charger.

Safety information

ROBOTIC VACUUM CLEANER

- Do not pick up hard or sharp objects such as glass, nails, screws, coins, and etc.
- Do not use without a filter in place. When servicing the unit, never put fingers or other objects into the fan chamber in case the unit accidentally turns on.
- Do not put any objects into openings. Do not use with any openings blocked; keep openings free of dust, lint, hair, and anything that may reduce air flow.
- Do not pick up toxic materials (chlorine bleach, ammonia, drain cleaner, etc.).
- Do not pick up anything that is burning or smoke, such as cigarettes, matches, or hot ashes.
- Do not use to pick up flammable or combustible liquids such as gasoline, nor use on areas where they may be present.
- Do not use robotic vacuum cleaner in an enclosed space filled with vapours given off by oil based paint, paint thinner, moth proofing substances, flammable dust, or other explosive or toxic vapours.
- Leaks from battery cells can occur under extreme usage or temperature conditions. If the liquid gets on skin, wash quickly with water. If the liquid gets into the eyes, flush them immediately with clean water for a minimum of 10 minutes. Seek medical attention.

Contents

SAFETY INFORMATION	06	Power related
	07	Before use
	10	In use
	11	Cleaning and maintenance
	02	
PRODUCT FEATURES	13	
	13	Product Features
ASSEMBLING THE CLEANER	15	
	15	Components
	16	Name of each part
OPERATING THE CLEANER	20	
	20	Installing robotic vacuum cleaner
	20	Installation order
	20	Turning the power switch on or off
	21	Installing the charger
	22	Charging
	23	About the battery
	24	Setting the Time
	25	Installing the VIRTUAL GUARD
	27	Attaching a mop (option)
	28	Using robotic vacuum cleaner
	28	Starting/stopping cleaning
	29	Recharging
	30	Auto cleaning
	31	Spot cleaning
	32	Max cleaning
	33	Manual cleaning
	34	Scheduled cleaning
	35	Setting daily cleaning
	36	Using additional functions (Turbo Mode, Edge Mode)
MAINTAIN TOOLS AND FILTER	36	
	36	Cleaning robotic vacuum cleaner
	36	Please keep the cleaning and maintenance methods in mind
	37	Cleaning the sensor window and the camera
	37	Emptying the dust bin quickly
	38	Cleaning the dust bin and the filter
	39	Cleaning the power brush
	41	Cleaning the edge-cleaning side rotating brush
	42	Cleaning the driving wheel
	42	Caring for the mop (option)
TROUBLESHOOTING	43	
	43	Checklist before svc calls
	45	Troubleshooting for Error Codes
PRODUCT SPECIFICATION	46	
	46	Product specification
	46	

Safety information

POWER RELATED



Do not bend the power cord forcefully or place a heavy object on it that could break it.

- This may result in fire or electric shock.

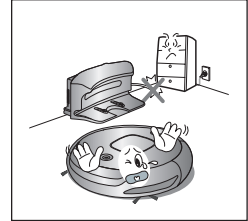

Make sure to remove any dust or water from the power plug.

- Failing to do so may result in a malfunction or electric shock.

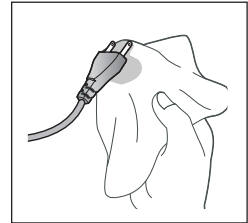

Do not pull the power plug by the cord or touch the plug with wet hands.

- This may result in fire or electric shock.

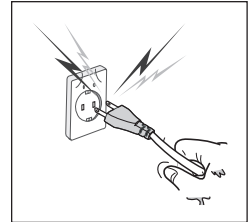

Do not use multiple plugs in a single socket. (Do not leave the cord lying exposed on the floor.)

- This may result in fire or electric shock.

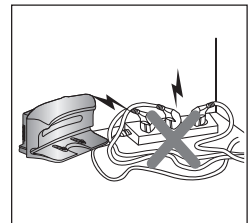

Do not use a damaged power cord, plug, or a loose power outlet.

- This may result in fire or electric shock.

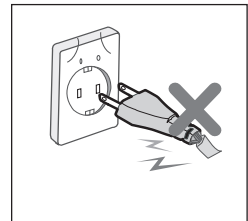

Safety information

BEFORE USE



Before activating the robotic vacuum cleaner, make sure that the dust bin is assembled.

- If the dust bin is not inserted, robotic vacuum cleaner will not operate.

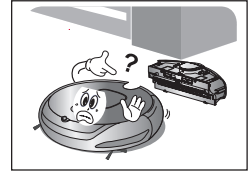

Never use robotic vacuum cleaner in locations with combustible material such as:

- Locations with candles or desk lamps on the floor.
- Locations with unattended fires (fire or embers).
- Locations with gasoline, distilled alcohol, thinner, ashtrays with burning cigarettes, etc.

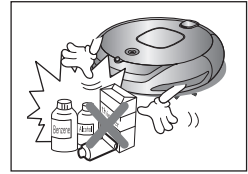

Robotic vacuum cleaner is for domestic use only. Do not use it in the following locations.

- Attics, basements, warehouses, industrial buildings, separate rooms distant from the main building, locations exposed to wet or damp conditions such as bathrooms or wash rooms, and narrow and highly situated locations such as tables or shelves. Critical damage (abnormal operation and breakage) may occur when used in these locations.



Open all doors to clean all rooms.

- When a door is closed, the robotic vacuum cleaner will not be able to enter that room.
- However, make sure to close the doors to the main entrance, the veranda and the bathroom, and any other rooms where the robotic vacuum cleaner may fall to a lower floor.



For carpets with long tassels, fold the tassels under the carpet.

- Unfolded tassels may result in critical damage to the carpet and the machine itself, as they get caught in the driving wheel or the power brush.

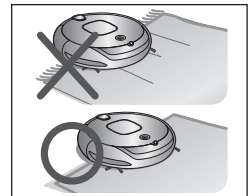

When the cliff sensor is polluted, the robotic vacuum cleaner may be in danger of falling down the stairs.

This may cause personal injury and critical damage to the product.

To prevent risk, install the VIRTUAL GUARDS (Fence Mode setting) in front of dangerous areas. Clean the sensor window and camera.

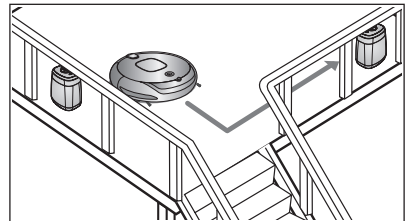

Safety information

BEFORE USE



Remove small objects or brittle items from the area to be cleaned in advance.

- Make sure to clear any objects before cleaning.
- Make sure to remove fragile items such as china, glass objects, flowerpots, etc.
- Robotic vacuum cleaner does not recognize coins, rings or other valuable items such as jewelry.



Remove objects scattered on the floor before cleaning.

- Robotic vacuum cleaner is designed to detect obstacles 5cm away from it.
- Bath towels, pads in front of bathrooms and sinks, entrances, utility rooms, power cords, table cloths or belts can become entangled in the driving wheel or power brush. This can cause objects to fall from the table.



Inform all family members (or relevant parties) to be cautious before cleaning or when using the Scheduled Cleaning Mode.

- Robotic vacuum cleaner may run into children, causing them to fall.



Ensure that children do not step or sit on the robotic vacuum.

- Children may fall and injure themselves or critical damage may occur to the product.



When a child or pet is left alone, make sure to turn off the Power Switch of the robotic vacuum cleaner.

- Robotic vacuum cleaner may attract their attention.
- When the rotating wheel or brush catches fingers, feet, clothing or hair, this may result in injury.
- If a child or pet is in the way of the robotic vacuum cleaner, it may be identified as an obstacle and the area may not be cleaned.
- When the Power Switch is turned off, it will cut off the power supply and deactivate all functions.



When installing the charger station, do not leave the power cord exposed on the floor.

- When the robotic vacuum cleaner automatically recharges or passes by the charger station, it may drag the power cord around with it.

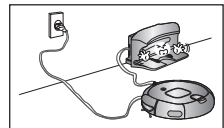

Always keep the power cord of the charger plugged into the outlet.

- Although the robotic vacuum cleaner has a self-charging function, if the power cord of the charger station is unplugged, it cannot charge its battery automatically.

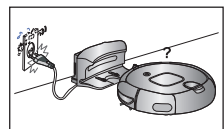

Safety information

BEFORE USE



Install the charger in a location that can be easily accessed by the robotic vacuum cleaner.

- If the charger is installed in a corner, this may cause extra movements and may disturb the automatic recharging process.

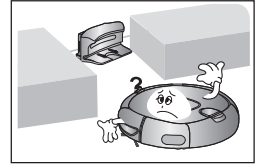

Objects in front of the charger will prevent the robotic vacuum cleaner from auto-charging itself.

- Clear the area.

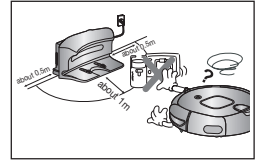

There should be no obstacles 0.5 m to the left and right and within 1 m of the front.

- Clear the area.

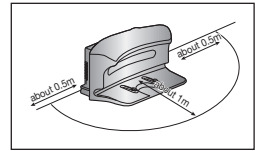

Do not short-circuit the charge pins with metal objects such as chopsticks, screwdrivers, and etc.

- This will result in critical damage to the charger.

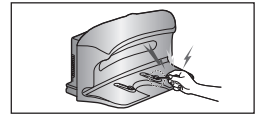

Make sure that there is no trace of liquids on the charger station.

- Failing to do so may result in fire or electric shock.



Make sure the robotic vacuum cleaner does not vacuum or move over liquids such as water, oil or pet litter.

- This may result in critical damage to the product.
- Liquids may spread through the wheels resulting in contamination.

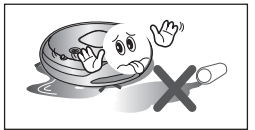

Do not use the cleaner on a black floor.

- The vacuum cleaning robot may not run normally in this case.

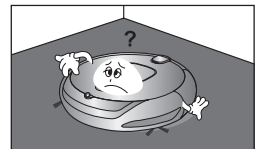

Do not use the charger for other purposes.

- This may result in critical damage to the charger or cause a fire.

Safety information

IN USE



You cannot use the robotic vacuum cleaner on thick carpets.

- This may result in problems with the robotic vacuum cleaner.
- This may result in damage to carpets.

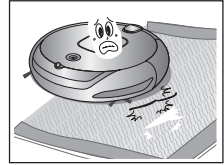

Do not use the robotic vacuum cleaner on a table or other high locations.

- This may result in damage when the unit accidentally drops.



Robotic vacuum cleaner may bump into furniture such as chair legs, table legs, thin and long furniture, etc. while operating.

- For a quicker and cleaner performance, place the chairs on top of the table.

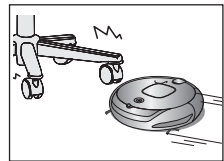

Do not place any objects on top of the robotic vacuum cleaner.

- This may result in malfunction.



Immediately remove any large pieces of paper or plastic bags from the machine while cleaning.

- Using the machine for an extended period of time with its inlet port obstructed may result in critical damage to the product.

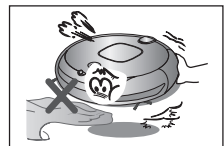

If an unusual sound, smell or smoke is emitted from the robotic vacuum cleaner, immediately turn off the Power Switch and call the customer care center.

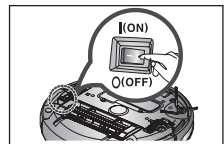

Robotic vacuum cleaner may not be able to continue its operation if it is stuck at the entrance or veranda doorsill.

- Robotic vacuum cleaner stops operating for safety reasons if it cannot move for more than 5 minutes.
- To resume operating, turn the Power Switch off and then on again after moving it to a location where it can continue cleaning.

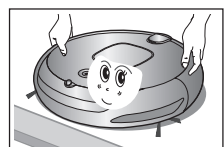

Safety information

IN USE



Robotic vacuum cleaner cannot completely clean locations that it cannot reach, such as corners, and spaces between sofas and walls.

- Please clean these locations occasionally.

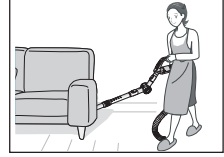

Dust clusters may remain after cleaning, when the robotic vacuum cleaner fails to pick up dust clusters that were formed while cleaning.

- In this case, sweep up the dust with another cleaning tool.



The cleaning robot cannot move over carpets after the mop is attached. (option)

- To clean a carpet, remove the mop and mop plate first.

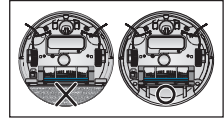

This product is not suitable for wet mops. (option)



CLEANING AND MAINTENANCE



When cleaning the product, do not spray water directly onto the exterior or wipe it with a volatile material such as benzene, thinner or alcohol.

- This may result in critical damage to the product.

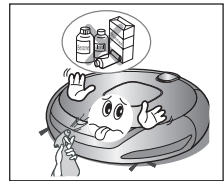

Do not forcefully press the bumper on the robotic vacuum cleaner.

- If the bumper sensor gets damaged, the robotic vacuum cleaner may bump into walls or furniture.

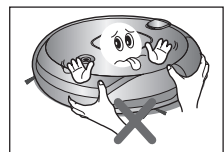

The unit must not be disassembled or reconstructed by anyone other than a qualified service engineer.

- This may result in damage to the product.



Safety information

CLEANING AND MAINTENANCE



Remove any foreign substances accumulated on the Obstacle and Cliff sensors on a regular basis.

- Dirt accumulated on the sensors will result in inaccurate functioning of the sensors.

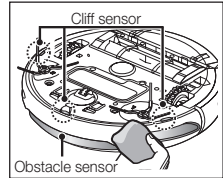

When removing foreign substances, always use the cleaning brush after turning the Power Switch off.

- Failing to do so may result in sudden operation of the unit and cause an injury or critical damage to the product.

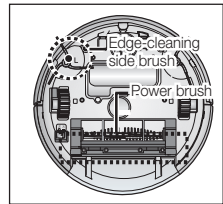

If the power cord is damaged, have it replaced by a qualified service engineer from the customer care center.

- Failing to do so may result in fire or electric shock.



Before cleaning the charger, make sure to disconnect the power cord for safety.



After cleaning, wash the mop and dry it completely before using it again. (option)

- Failing to do so may result in bad odors.

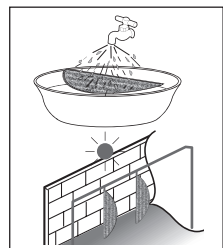

Contact the Samsung Electronics customer care center to replace the battery.

- Failing to use original batteries will result in product failure.

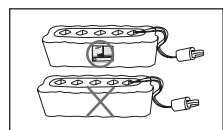

Product Features

CONVENIENT VIRTUAL GUARD FUNCTION

You can confine the robotic vacuum cleaner to a particular section by using the Fence (virtual wall) mode or by cleaning several sections one by one using the Guard (virtual door) mode.

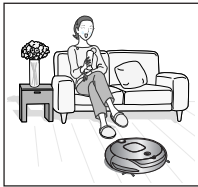

• What is ceiling shape recognition (Visionary mapping™)?

This function recognizes the shape of the ceiling using the camera on top to identify the area to be cleaned and determines the best way to pass over and clean every section of the floor.

DELICATE CLEANING OF EVERY CORNER

Since the robotic vacuum cleaner cleans the floor in a sequential way (→) along the map determined by the ceiling shape recognition function, it cleans every corner of the floor.

VARIOUS CLEANING MODES

Various cleaning modes are provided to meet all your needs.

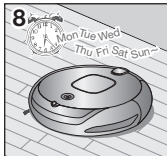
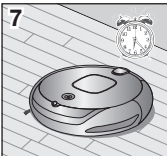
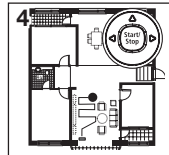
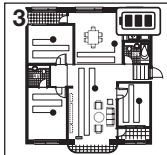
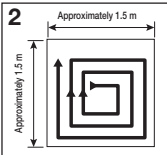
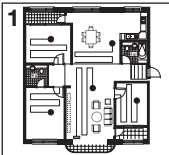

1. Auto Mode :

Cleans all rooms automatically.

2. Spot Mode :

Cleans a localized area intensely. It can be used to clean bread or cookie crumbs.

3. Max Mode : Runs until the battery is nearly depleted.

4. Manual Mode : You can clean the floor manually by moving the cleaning robot.

5. Turbo Mode : Since the power brush rotates at maximum speed in this mode, the product will clean more effectively. (You can switch the mode with the remote control.)

6. Edge Mode : When the Obstacle Sensor detects an obstacle during the cleaning, the Robot Cleaner reduces its speed to minimize the bumping impact and the Bumper Sensor also helps it lower the bumping impact. And, it cleans the corners by reaching to them as close as possible.

7. Scheduled Cleaning Mode : At the specified time, the cleaning robot cleans the floor.

8. Daily Cleaning Mode : The cleaning robot cleans the floor everyday at the specified time.

EASY DUST OUTLET

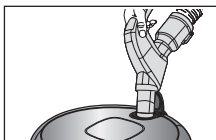

The dust output at the top enables emptying the dust bin easily using a normal vacuum cleaner without dust flying around.

Product Features

AUTO CHARGING

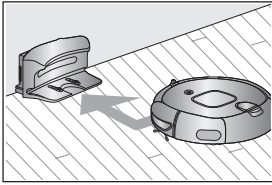

When the battery is low, the robotic vacuum cleaner is automatically guided to the charger to enable it to perform a quick auto charge.

EDGE-CLEANING SIDE ROTATING BRUSH

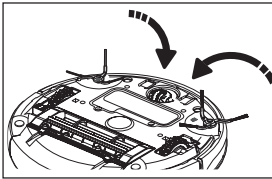

The edge-cleaning side rotating brush cleans dust from the edges.

DOORSILL CROSSING

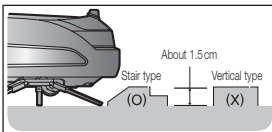

The robotic vacuum cleaner's innovative driving system makes it possible for it to cross over doorsills with a height of about 1.5cm and clean all rooms. The robotic vacuum cleaner may not be able to pass a 1.5cm doorsill depending on the shape of the doorsill.

ANTI-CRASH

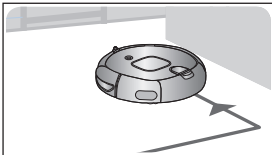

The robotic vacuum cleaner detects and avoids obstacles in 2 stages. First, the 8 obstacle sensors detect obstacles in stage 1 and if the robotic vacuum cleaner does crash into an obstacle, the 2 bumper sensors absorb the impact.

ANTI-FALLING

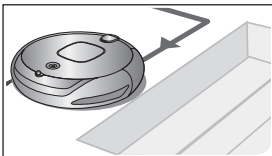

The 3 Cliff sensors detect downward steps such as stairs or the front door threshold to prevent robotic vacuum cleaner from falling down stairs.

SAFETY DEVICE

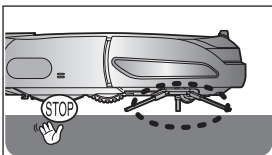





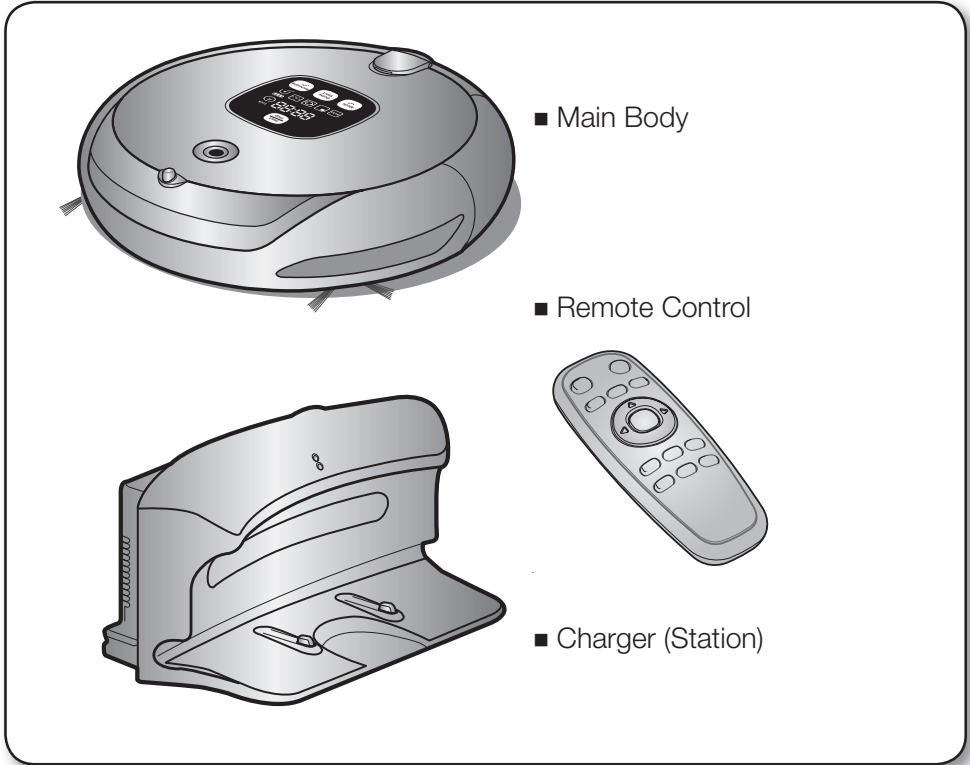

When the robotic vacuum cleaner is lifted up while cleaning, the driving wheels, power brush, suction motor, and side rotating brush are stopped automatically by sensor.

Assembling the cleaner

COMPONENTS

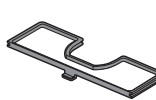

■ Others Components

<p>(AAA-Type Batteries)</p>  <p>User Manual / 2 Battery</p>	 <p>VIRTUALGUARD</p>	 <p>Spare Filter</p>	 <p>Cleaning Brush</p>
 <p>Remote Control Cradle</p>	<p>(option)</p>  <p>Microfiber Mop</p>	<p>(option)</p>  <p>Mop Plate</p>	

Assembling the cleaner

NAME OF EACH PART

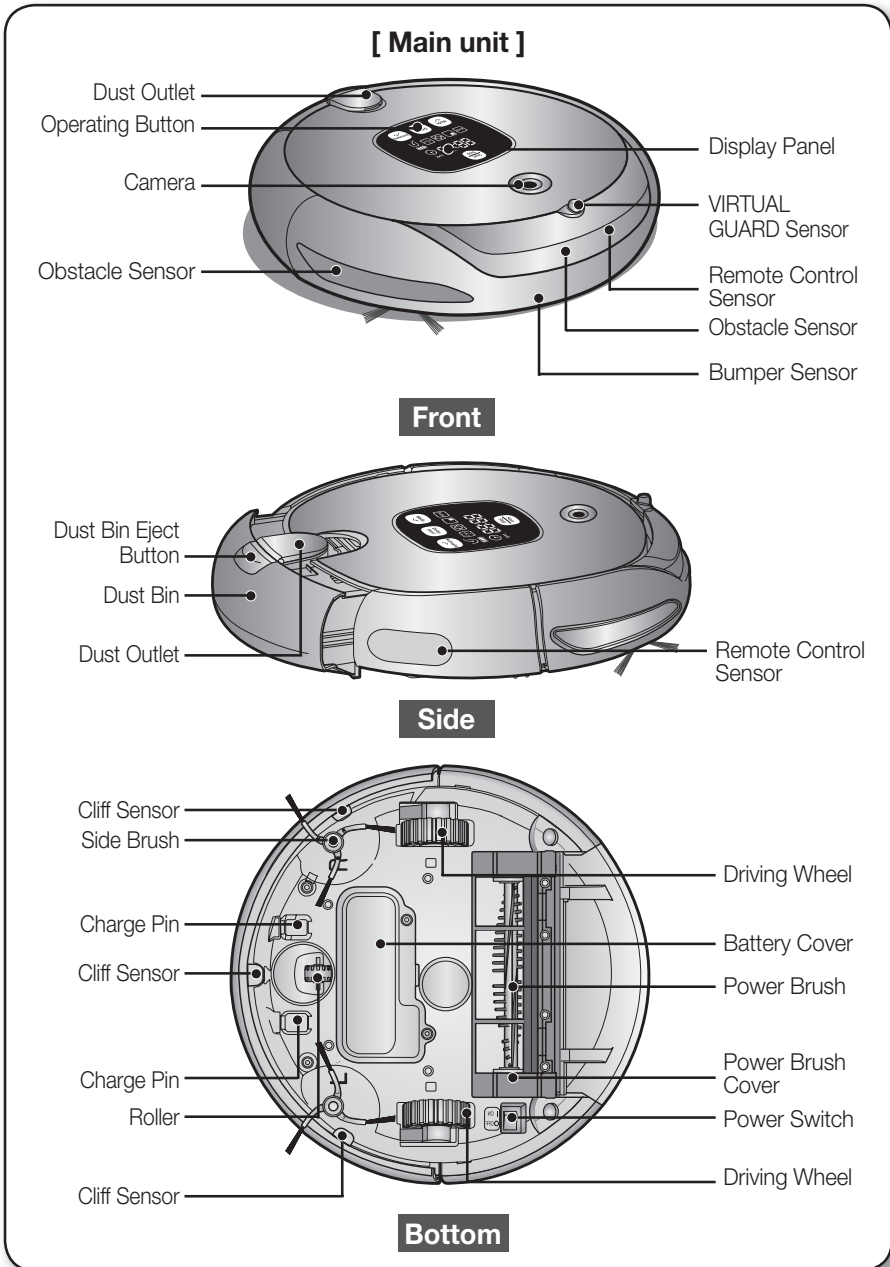

Assembling the cleaner

NAME OF EACH PART

[Charger (Station)]

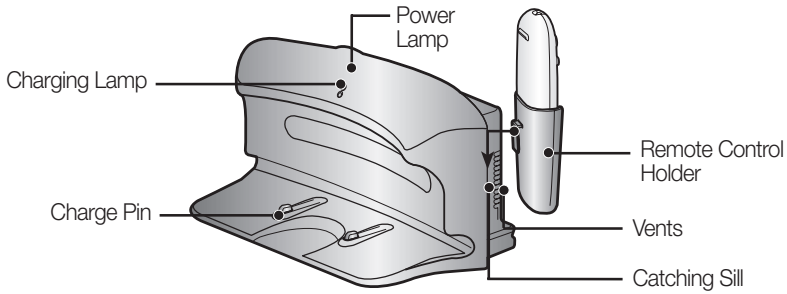

[VIRTUAL GUARD]

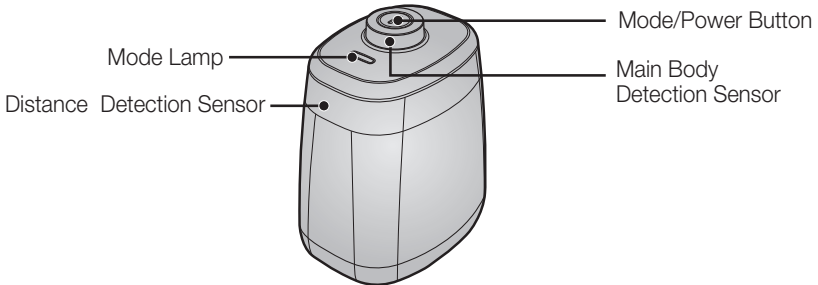

■ Installing the batteries

Batteries are not supplied with the product. You have to purchase the batteries separately. Install the alkaline batteries (type D) before use.

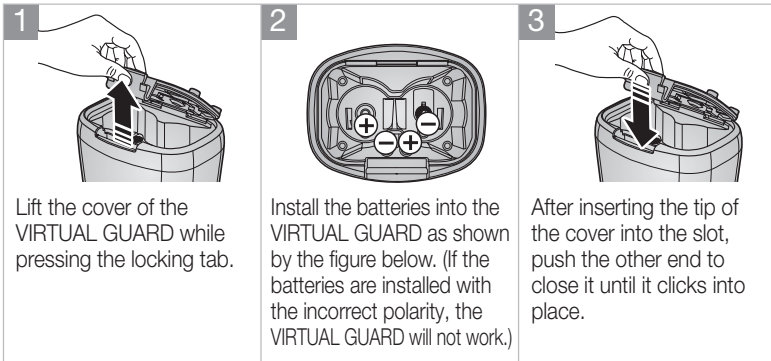

* Specification: Alkaline Type D (LR20) batteries

Assembling the cleaner

NAME OF EACH PART

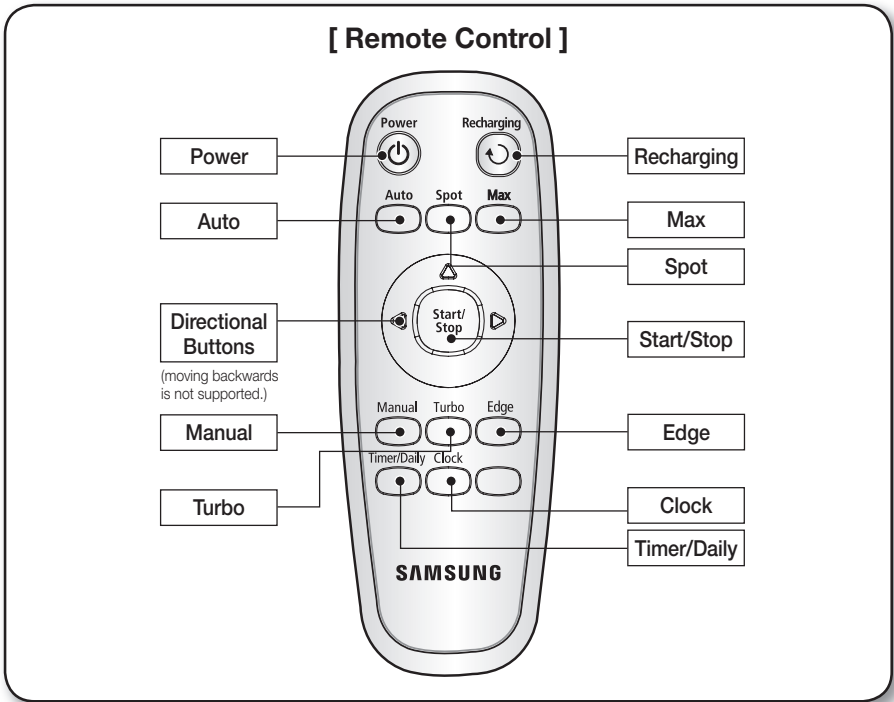

■ Installing the Remote Control Batterise

Batteries are not installed in the remote control when purchasing the product. Install the batteries (type AAA) before use.

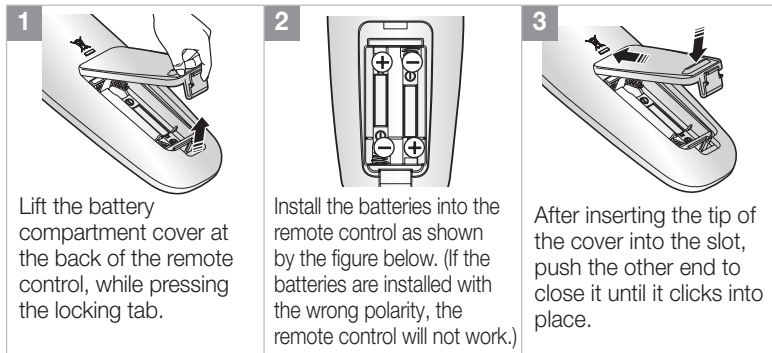

* Specification: AAA type batteries

Assembling the cleaner

NAME OF EACH PART

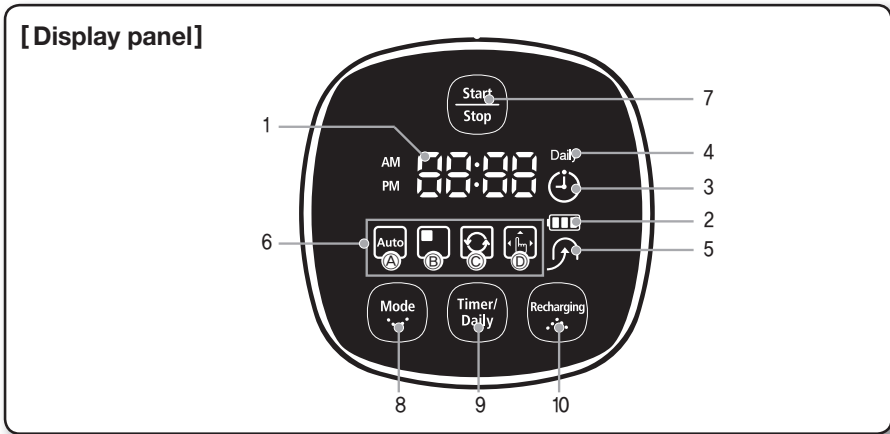

DISPLAY PART

1. Number Display

- Shows the timer display, progress status, and error codes using numbers, letters and graphics.

2. Battery Level Indicator

- Charging : Shows the charging progress in 3 steps.
- In Use : Shows the battery charge level. The battery charge level is reduced by each level from FULL while operating. (When the battery is fully discharged, one level will flash to display "LO".)

3. Scheduled Cleaning

- When cleaning is scheduled, the Scheduled Cleaning icon is lit.

4. Daily

- When daily cleaning is scheduled, the Daily icon is lit.

5. Recharging

- This icon turns on when the cleaning robot returns to the charger station to charge its battery.

6. Cleaning Mode Display

- Each time the Cleaning Mode button is pressed, the corresponding cleaning mode is displayed.
 - (a) Auto Mode : This icon turns on when Auto cleaning mode is selected.
 - (b) Spot Mode : This icon turns on when Spot cleaning mode is selected.
 - (c) Max Mode : This icon turns on when Max cleaning mode is selected.
 - (d) Manual Mode : This icon turns on when Manual cleaning mode is selected.

BUTTON PART

7. Start/Stop

- Press to start/stop cleaning.

8. Cleaning Mode

- Press to select a cleaning mode. After selecting a cleaning mode, press the () button to start cleaning.

9. Timer/Daily

- Press to set a scheduled or daily cleaning.

10. Recharging

- When this button is pressed, the Recharging icon is turned on and the cleaning robot will return to the charger station to charge its battery.

Operating the cleaner

INSTALLING THE ROBOTIC VACUUM CLEANER

INSTALLATION ORDER

1. Turning the Power Switch on or off

To use the robotic vacuum cleaner, you must turn on the Power Switch at the bottom of the main unit.

2. Installing the Charger

To charge the robotic vacuum cleaner, you must first install the charger.

Since the battery is discharged when the product is purchased, you must fully charge the battery before use.

3. Charging the Battery

You should charge the battery completely before using the robotic vacuum cleaner.

4. Setting the Time

You should set the time to use the scheduled and daily cleaning options.

5. Installing the VIRTUAL GUARD

You can confine the robotic vacuum cleaner to a particular section by using Fence (virtual wall) mode or clean several sections one by one using Guard (virtual door) mode.

6. Attaching a mop

Attach the mop to the bottom of the cleaning robot.



TURNING THE POWER SWITCH ON OR OFF

To use the robotic vacuum cleaner, you must turn the Power Switch on.

If you turn the Power Switch off, all settings will be reset.

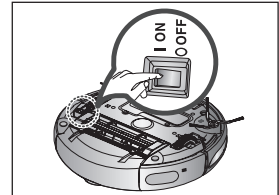

1. Turn over the main unit and turn the Power Switch on.

- If the icons are not turned on, it indicates that the battery charge is depleted. In this case, dock the robotic vacuum cleaner to the charger station after turning the Power Switch on.
- The configured time may be different from the current time. If the configure time is incorrect, set the time to the current time.

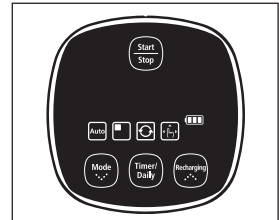

- * If no key is pressed for approximately 5 minutes after turning the power on, the power is automatically cut to prevent the battery discharging. To turn the power on again, press and hold the power (Run/Stop) button on the main body or on the remote control for a short while.



If the Power Switch is turned off, the robotic vacuum cleaner will not be charged even if it is docked with the charger station.

Operating the cleaner

INSTALLING THE ROBOTIC VACUUM CLEANER

INSTALLING THE CHARGER

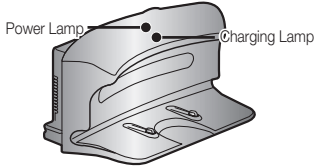

1. Install the charger on a flat surface.

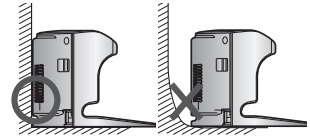

2. There should be no obstacles 0.5m to the left and right and within 1 m of the front.

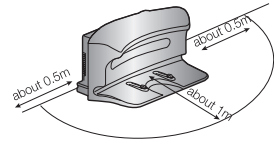

3. Install the charger in a location where it can be easily accessed by the robotic vacuum cleaner.



4. Arrange the power cord along the wall.

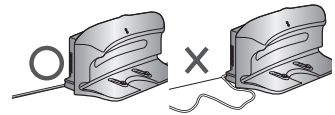

5. When the floor is made of wood, install the charger in the same direction as the grain of the wood.

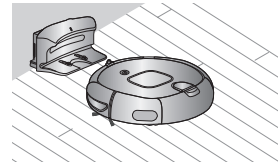

NOTE

Always keep the power cord of the charger plugged into the power outlet.

- If no power is supplied to the charger, the robotic vacuum will not be able to find the charger and will not be able to charge automatically.
- If the robotic vacuum cleaner is separated from the charger, the battery is automatically discharged.

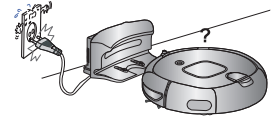

Operating the cleaner

INSTALLING THE ROBOTIC VACUUM CLEANER

CHARGING

When the product is initially purchased, the battery is fully discharged, and you must charge the robotic vacuum cleaner manually.

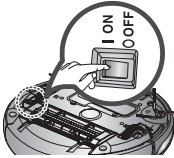

Turn on the Power Switch at the bottom of the product.

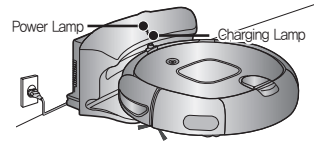

1. After aligning the charge pins of the main unit with the charge pin of the charger station, press the main unit until you hear a “Recharging power” sound from the charger.

- The Charging Lamp turns green.

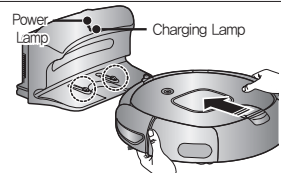

2. Check the charge status of the robotic vacuum cleaner.

- When charging starts, the battery level indicator and “B” will be displayed in sequence in the display panel.
- When charging is complete, the battery level indicator and “FULL” will be displayed in the display panel.

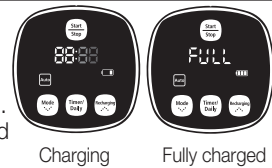

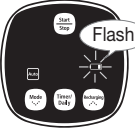

- When the battery level display flashes while cleaning, the robotic vacuum cleaner stops vacuuming and automatically charges itself at the charger.
- When the battery level flashes and “LO” is displayed while cleaning, robotic vacuum cleaner cannot be operated by the remote control or the buttons on the main unit. In this case, directly carry the robotic vacuum cleaner to the charger to charge the battery. (This is when the battery is completely discharged.)

<Charge display>

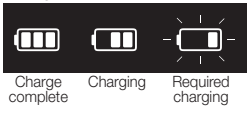

Charge complete Charging Required charging



- When the product is initially purchased, it will take about 120 minutes to fully charge the battery and will run for about 90 minutes.
- When charging the battery while the battery is over-heated, the charging time can increase.
- Measures to take when charging is not smooth.

When the robotic vacuum cleaner cannot be automatically charged, check the following:

- Turn the Power Switch at the bottom of the robotic vacuum cleaner off and on (Reset).
- Re-plug the power of the charger (Reset).
- Check whether there are any foreign substances on the charge connector and wipe the charge connector on the main unit and the charger with a dry cloth.
- Check whether there are objects near the charger that are strong reflectors.
- When separating the robotic vacuum cleaner from the charger, it will discharge naturally.
 - Charge the robotic vacuum cleaner through the charger, if possible. (When leaving your home unattended for a long period of time due to a business trip, travelling etc., turn off the Power Switch of the robotic vacuum cleaner and unplug the power of the charger to store them.)

Operating the cleaner

INSTALLING THE ROBOTIC VACUUM CLEANER

ABOUT THE BATTERY

- The robotic vacuum cleaner is powered by an environment-friendly Nickel Metal Hydride (NiMH) rechargeable battery, and an over-charge prevention function guarantees an extended life time.
- **The battery warranty period is 6 months from the date of purchase.**
- When purchasing a battery, ask the customer care center for the genuine part symbol () and model number before purchasing it.

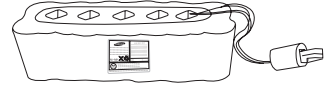

- This battery is only for Samsung robotic vacuums. It is strictly prohibited to use it for other appliances or for other purposes.
- Do not disassemble or modify the battery.
- Charge it in a location with good ventilation.
- Do not expose the battery to fire and do not heat it.
- Do not connect any metallic objects to the (+) or (-) terminals of the battery.
- Keep it indoors (0°C~40°C).
- Before you discard product, dispose of batteries in an environmentally safe manner.
- Do not discard this batteries with your regular household trash.
- Follow all local regulations when disposing of old batteries.

- * If the battery is out of order, do not disassemble it. Contact your nearest customer care center.
- * An increased charging time and a shorter battery life indicates the near end of the battery life. Please contact an authorized customer care center to replace your battery.

The rechargeable battery incorporated in this product is not user replaceable. For information on its replacement, please contact your service provider.

Operating the cleaner







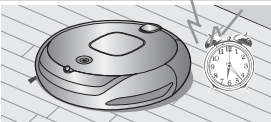
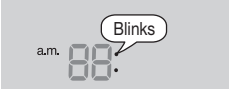

INSTALLING THE ROBOTIC VACUUM CLEANER

SETTING THE TIME

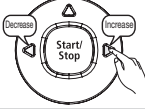
To use the Scheduled Cleaning and Daily Cleaning functions properly, setting the time is necessary.

You can only set the time using the remote control.

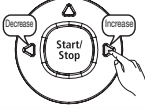
- You can only set the time using the remote control.

	Remote Control	Configuration Sequence
 <p>Suppose current time is 07:00</p> 		
		1 Enter the current "hour".
		2 Enter setup mode.
		3 Set the "hour".
		4 Enter the current "minutes".
		5 Finish the setting.

- Press the  button instead of the Time Set button while setting the time to exit Time Set mode.

- When a Scheduled Cleaning is set, you cannot change the time setting.

Operating the cleaner

INSTALLING THE ROBOTIC VACUUM CLEANER

INSTALLING THE VIRTUAL GUARD

You can confine the robotic vacuum cleaner to a particular section by using Fence (virtual wall) mode or clean several sections one by one using Guard (virtual door) mode.

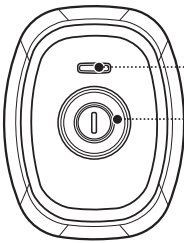
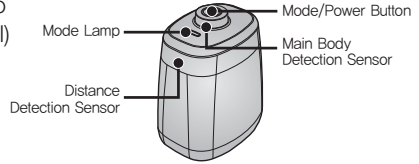

Button operations

1. Mode lamp operations

- Fence (virtual wall) Mode: The red lamp flashes.
- Guard (virtual door) Mode: The green lamp flashes.
- Off : The lamp is turned off.

2. Setting the mode

- Whenever you press the Mode/Power button, Fence (virtual wall) mode → Guard (virtual door) mode → Power off is selected in this sequence.

* The distance of virtual wall is 2.5M at minimum and may differ depending on surroundings and movement status of the robot.

Forming a Fence (virtual wall)

VIRTUAL GUARD creates an invisible barrier that the robotic vacuum cleaner cannot cross. E.g. in front of pots, furniture, the front door, and so on.

1. Select Fence (virtual wall) mode using the Mode/Power button.

- The mode lamp flashes red.

2. Install the VIRTUAL GUARD in front of the area you want to block access from the robotic vacuum cleaner.

- Install the VIRTUAL GUARD so that the distance detection sensor can form an invisible barrier that the robotic vacuum cleaner cannot cross.

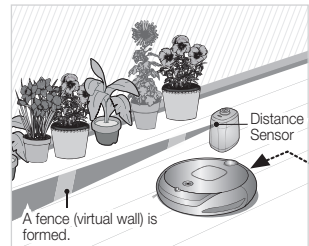

Operating the cleaner

Using Guard (virtual door) mode

The VIRTUAL GUARD forms an invisible door that the robotic vacuum cleaner cannot cross until current room is completely cleaned. The VIRTUAL GUARD opens the invisible door when cleaning the of room is complete.

1. Select Guard (virtual door) mode using the Mode/Power button.

- The mode lamp flashes green.

2. Install the VIRTUAL GUARD at the entrance of the room to be cleaned.

- Install the VIRTUAL GUARD so that the distance detection sensor can form an invisible barrier that the robotic vacuum cleaner cannot cross.

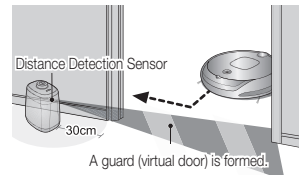
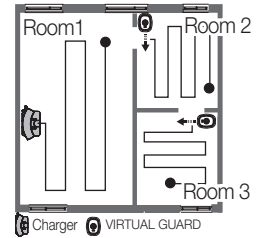

- When not using the VIRTUAL GUARD, turn the power off. (When not using the robotic vacuum cleaner for long periods of time, separate the batteries to avoid discharging them.)
- If the Mode/Power button does not work, it indicates that the batteries have worn out. In this case, replace the batteries. (Specifications: Type D (LR20) alkaline batteries)
- You can additionally purchase a VIRTUAL GUARD from Samsung Electronics customer care Co., Ltd.

* Since an invisible barrier is formed to prevent the robotic vacuum cleaner from running against the VIRTUAL GUARD, installing the VIRTUAL GUARD within 30 cm of the outside walls is recommended.



About the IrDA sensor.

- The infrared signal transmission may not be smooth in locations exposed to halogen lamps or in outdoor locations.
- Robotic vacuum cleaner uses 3 types of infrared devices and a device may not work in front of another device with a higher priority.
- When controlling the robotic vacuum cleaner with the remote control, the robotic vacuum cleaner may cross the virtual fence of the VIRTUAL GUARD or run against an obstacle, because the remote control signal has a higher priority than the VIRTUAL GUARD signal.
- When using the robotic vacuum cleaner in a small location or at a close distance, it may malfunction due to interference of the infrared signals.
- Install the VIRTUAL GUARD away from the charger as auto charging may be interrupted if the VIRTUAL GUARD is near the charger.
- If more than one robotic vacuum is used simultaneously, they may malfunction due to interference of the infrared signals.

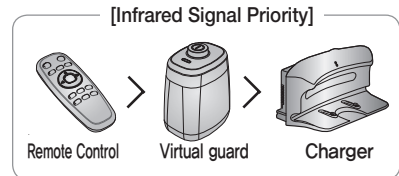

Operating the cleaner

USING THE ROBOTIC VACUUM CLEANER

ATTACHING A MOP (OPTION)

You can effectively remove dust with the microfiber mop.

Mop attachment procedures

1. Attach the mop to the Velcro fastener of the mop plate.

- Attach the mop making sure that the mop attachment line is not covered.

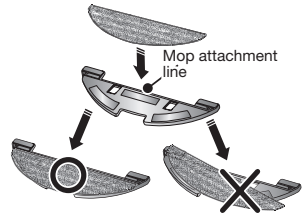

* Attach the mop making sure it is level with the mop attachment line.

2. Align the holes of the mop plate with the parts at the bottom of the cleaning robot and push the parts until they 'click' into place.

- Note that if you install the mop plate incompletely, it may separate while cleaning.

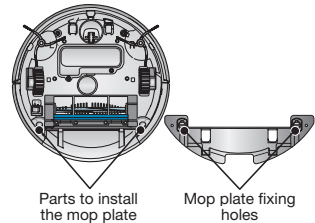

3. Place the mop plate to which the mop is attached on the floor and push it down.



- Since the cleaning robot cannot move over carpets after attaching a mop, remove the mop and mop plate from the cleaning robot before cleaning a carpet.
- After cleaning, wash the contaminated mop.
- Use the mop only after completely drying it. (You cannot use a wet mop.)
- If there is liquid such as coffee on the floor, do not use the mop to clean it to prevent secondary contamination of the floor by the liquid.

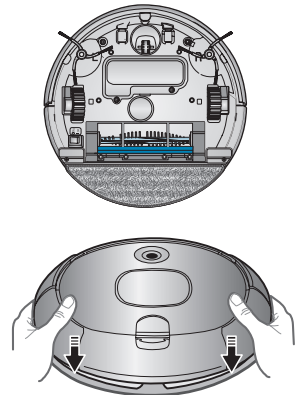

Operating the cleaner

USING THE ROBOTIC VACUUM CLEANER

STARTING/STOPPING CLEANING

You can run or stop all robotic vacuum functions.

- Each robotic vacuum function only runs when the Power Switch is turned on.
- When the robotic vacuum is operating, press the  button to cancel the operation and select a function.

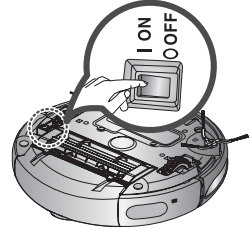

Turning the power on or off

Turning the power on

- Remote control : Press the **[Power]** button.
- Main unit: Press the .

Turning the power off

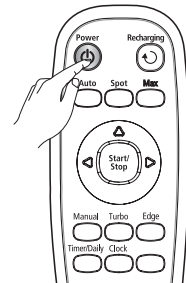

- Remote control: Press the **[Power]** button.
- Main unit: Press and hold the  button down for 3 seconds.



Using the remote control

Starting or stopping cleaning

Starting

- Remote control : Press the Auto, Spot, Max, Manual or button.
- Main unit : Select Auto / Spot / Max / Manual mode by using the  button and then pressing the  button.
- When cleaning begins, the robotic vacuum cleaner starts to move.
- * Pressing the  button without selecting cleaning mode starts to perform the Auto mode cleaning.

Stopping

- To stop, press the  remote control or main unit button.
- When cleaning is stopped, the robotic vacuum cleaner stops.

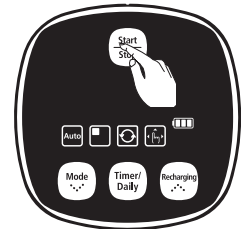

Using the main unit buttons

Operating the cleaner

USING THE ROBOTIC VACUUM CLEANER

RECHARGING

You can have the robotic vacuum cleaner return to the charger to charge the battery by using the Recharging button.

- When the robotic vacuum cleaner is operating, press the  button to cancel the operation and press the Recharging button.

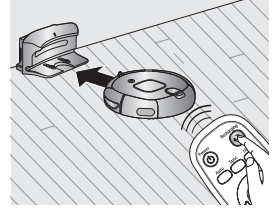

1. Press the Recharging button.

- The main unit icon  is turned on and the robotic vacuum cleaner will return to the charger.

2. To stop the robotic vacuum cleaner while it is returning to the charger, press the button.

3. To test the auto charge function, press the Recharging button when the robotic vacuum cleaner is less than 1.5m from the charger.

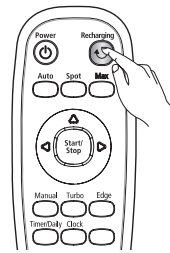

Using the remote control

Troubleshooting when the robotic vacuum cleaner does not return to the charger

- Check the installation of the charger
 - When the charger is in a location where the charger cannot guide the robotic vacuum cleaner to the charger.
 - When the charger is more than 5m away from robotic vacuum cleaner.
 - : It may require a longer time for the robotic vacuum cleaner to return to the charger.
- Manually charge the robotic vacuum cleaner in the following cases.
 - When the charger is installed in a corner.
 - When the battery is fully discharged.
 - When the robotic vacuum cleaner is trapped by an obstacle (furniture etc.)
 - When the robotic vacuum cleaner cannot pass over the doorsill to the location where the charger is installed.

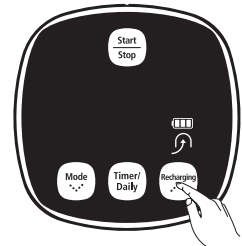

Using the main unit buttons

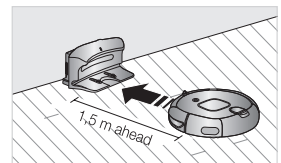

Operating the cleaner

USING THE ROBOTIC VACUUM CLEANER

AUTO CLEANING

The robotic vacuum cleaner will move by itself and automatically clean the house until cleaning is completed once.

- If cleaning begins when the robotic vacuum cleaner is docked with the charger station, the time to return to the charger is decreased since the robotic vacuum cleaner remembers its original position while moving.
- If the battery level becomes too low while cleaning, the robotic vacuum cleaner will automatically return to the charger station and resume cleaning after charging its battery. (Number of cleaning operations resumed : Once)

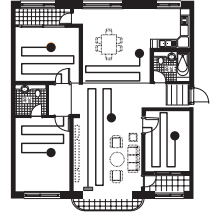

Main unit button	Remote control button	Configuration Sequence
		1 Set the mode.
		2 Cancel the mode.

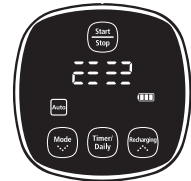

Normal Mode

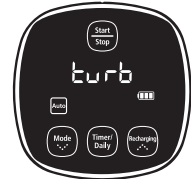

Turbo Mode



Edge Mode

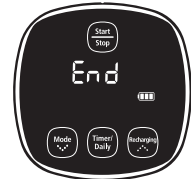

Cleaning Complete



About the Resume Cleaning function

- If the robotic vacuum cleaner has evaluated that cleaning is complete, the resume cleaning function is not performed.
- If you move the robotic vacuum cleaner when it is being charged or press a button, the robotic vacuum cleaner judges cleaning to be complete and does not resume cleaning.



- Do not move the robotic vacuum cleaner when it is cleaning or press a button while it is cleaning. Otherwise, the robotic vacuum cleaner judges cleaning to be complete and starts cleaning again from the beginning.
- When you press the Turbo remote control button, either On turbo (ON EE EEE) or Off turbo (OFF EE EEE) is displayed on the display panel in turns. When On turbo is displayed, you can clean the floor in Turbo Mode.
- When you press the Edge remote control button, On Edge (ON Ed 92) or Off Edge (OFF Ed 92) is displayed on the display panel in turns. When On Edge is displayed, you can clean the floor in Edge Mode.
- If you select both Turbo Mode and Edge Mode at the same time, the (EE EEE → Ed 92) is display on the display panel in turns.

Operating the cleaner

USING THE ROBOTIC VACUUM CLEANER

SPOT CLEANING

You can conveniently clean a specific area that has a lot of cookie crumbs, dust, and etc.

- Move the robotic vacuum cleaner to the location where you want to perform a spot clean.

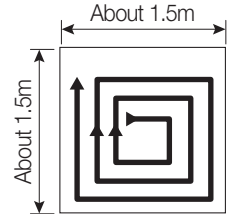

Main unit button	Remote control button	Configuration Sequence
		1 Set the mode.
		2 Cancel the mode.

- In Spot cleaning mode, the robotic vacuum cleaner cleans an area with a length of 1.5m and a width of 1.5m.
- When cleaning is completed, the robotic vacuum cleaner will display End, Stop, and Stand by.

NOTE When the robotic vacuum cleaner is docked with the charger station, spot cleaning is not supported.



- When you press the Turbo remote control button, either On turbo (On EE EE EE) or Off turbo (Off EE EE EE EE) is displayed on the display panel in turns. When On turbo is displayed, you can clean the floor in Turbo Mode.
- When you press the Edge remote control button, On Edge (On Ed 9E) or Off Edge (Off F Ed 9E) is displayed on the display panel in turns. When On Edge is displayed, you can clean the floor in Edge Mode.
- If you select both Turbo Mode and Edge Mode at the same time, the (EE EE EE → Ed 9E) is display on the display panel in turns.

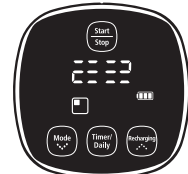

Normal Mode

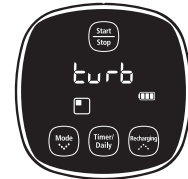

Turbo Mode



Edge Mode



Cleaning Complete

Operating the cleaner

USING THE ROBOTIC VACUUM CLEANER

MAX CLEANING

The robotic vacuum cleaner automatically moves and cleans until the battery runs out and the battery level flashes only one level.

- If cleaning begins when the robotic vacuum cleaner is docked with the charger station, the time to return to the charger is decreased since the robotic vacuum cleaner remembers its original position while moving.
- If the battery level becomes low while cleaning, the robotic vacuum cleaner automatically returns to the charger station and resumes cleaning after charging the battery. (Number of resumed cleaning operations: Once)

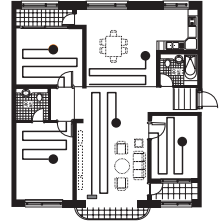

Main unit button	Remote control button	Configuration Sequence
		1 Set the mode.
		2 Cancel the mode.

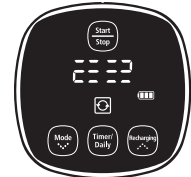

Normal Mode



Turbo Mode



Edge Mode



About the Resume Cleaning function

- If the robotic vacuum cleaner judges cleaning to be complete, resume cleaning is not performed.
- If you move the robotic vacuum cleaner while it is being charged or press a button, robotic vacuum cleaner judges cleaning to be complete (cleaning is not resumed).



- Do not move the robotic vacuum cleaner while it is cleaning or press a button while cleaning. Otherwise, the robotic vacuum cleaner judges cleaning to be complete and starts cleaning again from the beginning.
- When you press the Turbo remote control button, either On turbo (On Ed 92) or Off turbo (Off Ed 92) is displayed on the display panel in turns. When On turbo is displayed, you can clean the floor in Turbo Mode.
- When you press the Edge remote control button, On Edge (On Ed 92) or Off Edge (Off Ed 92) is displayed on the display panel in turns. When On Edge is displayed, you can clean the floor in Edge Mode.
- If you select both Turbo Mode and Edge Mode at the same time, the (Ed 92) is displayed on the display panel in turns.

Operating the cleaner

USING THE ROBOTIC VACUUM CLEANER

MANUAL CLEANING

You can move the robotic vacuum cleaner to clean a particular location directly by using the remote control.

- Move the robotic vacuum cleaner to the location where you want to perform manual cleaning.
- You can manually clean using the remote control only.

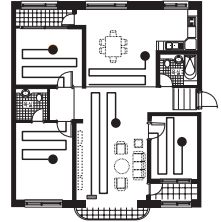

Main unit button	Remote control button	Configuration Sequence
		1 Set the mode.
		2 Cancel the mode.



- When the robotic vacuum cleaner is docked with the charger station, manual cleaning is not supported.



- When you press the Turbo remote control button, either On turbo (03 03 03 03) or Off turbo (0F 03 03 03) is displayed on the display panel in turns. When On turbo is displayed, you can clean the floor in Turbo Mode.
- When you press the Edge remote control button, On Edge (0A E0 90) or Off Edge (0F E0 E0 90) is displayed on the display panel in turns. When On Edge is displayed, you can clean the floor in Edge Mode.
- If you select both Turbo Mode and Edge Mode at the same time, the (03 03 03 → E0 90) is display on the display panel in turns.

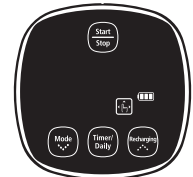

Normal Mode

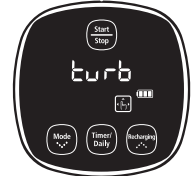

Turbo Mode



Edge Mode

Directional Buttons (Forwards, Left, Right)
A backwards function is not supported.

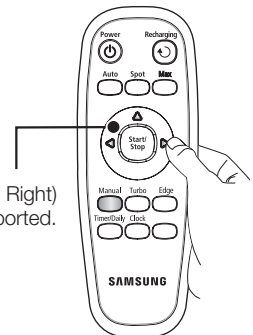

Operating the cleaner

USING THE ROBOTIC VACUUM CLEANER

SCHEDULED CLEANING

You can schedule robotic vacuum cleaner to start cleaning from a particular time.

- Scheduled cleaning is only performed when robotic vacuum cleaner is docked with the charger station.

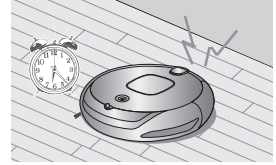

Main unit button	Remote control button	Configuration Sequence	(Example) The current time: 07:00 a.m. The desired cleaning start time: 09:30 a.m.
		1 Enter Scheduled Cleaning mode and confirm that the configured time is correct.	
		2 Start the settings.	
		3 Set the "hour".	
		4 Confirm the "hour".	
		5 Set the "minutes".	
		6 Complete the settings.	
		Cancel the settings.	 The icon is turned off.

NOTE When completing the settings, and you press the (Start/Stop) button instead of the Delay/Daily button, Scheduled Cleaning mode is exited.

Operating the cleaner

USING THE ROBOTIC VACUUM CLEANER

SETTING DAILY CLEANING

You can schedule the cleaning robot to start cleaning everyday from a particular time.

- Daily cleaning is only performed when the cleaning robot is docked with the charger station.

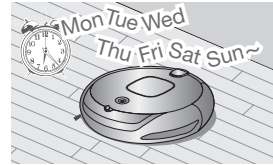

Main unit button	Remote control button	Configuration Sequence	(Example) The current time: 07:00 a.m. The desired cleaning start time: 09:30 a.m.
		1 Enter Daily Cleaning mode and confirm that the configured time is correct. (Check the daily reservation time.)	AM 07:00
		2 Start the setting.	AM 07: Blinks Daily
		3 Set the "hour".	AM 09: Blinks Daily
		4 Confirm the "hour"	AM 09:00 Blinks Daily
		5 Set the "minutes".	AM 09:30 Blinks Daily
		6 Complete the settings.	AM 09:30 Daily
		Cancel the settings.	Daily The icon is turned off.

NOTE When completing the settings, and you press the (Start/Stop) button instead of the Delay/Daily button, Daily Cleaning mode is exited.

Maintain tools and filter

USING ADDITIONAL FUNCTIONS

You can use the cleaning robot more easily and conveniently using various additional functions.

- You can only configure the additional functions with the remote control.

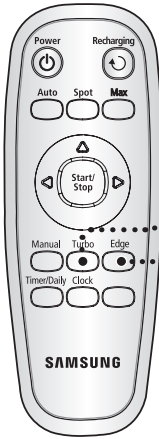

Turbo mode

When you press the Turbo remote control button, On turbo (ON TURBO) or Off turbo (OFF TURBO) is displayed on the display panel in turns.

On turbo (Turbo Mode) : The power brush rotates at maximum speed.

Off turbo (Normal Mode) : The power brush rotates at normal speed.

Edge Mode

When you press the Edge remote control button, On Edge (ON EDGE) or Off Edge (OFF EDGE) is displayed on the display panel in turns.

On Edge (Edge Mode) : The cleaning robot cleans the floor touching obstacles.

Off Edge (Evasion Mode) : The cleaning robot cleans the floor evading obstacles



NOTE When Off Edge (Evasion Mode) is displayed, the cleaning robot may bump into thin or dark obstacles.

CLEANING THE ROBOTIC VACUUM CLEANER

PLEASE KEEP THE CLEANING AND MAINTENANCE METHODS IN MIND

- When the Power Switch is damaged, please contact the service agent so that it does not cause any accidents.
- Do not use any means or mechanical devices not installed by the manufacturer that could accelerate the deformation of the robotic vacuum cleaner.

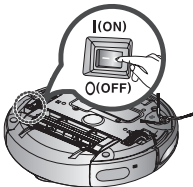

- Always turn off the power switch at the bottom of the main unit before cleaning the robotic vacuum. The robotic vacuum cleaner could operate suddenly and cause an injury.



Maintain tools and filter

CLEANING THE SENSOR WINDOW AND THE CAMERA

You must turn off the Power Switch at the bottom of the main unit before cleaning the robotic vacuum.

- Never spray water, thinner, benzene etc. directly onto the main unit of robotic vacuum cleaner.

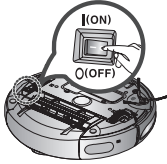

- Lightly wipe the sensor window or camera using a soft cloth.

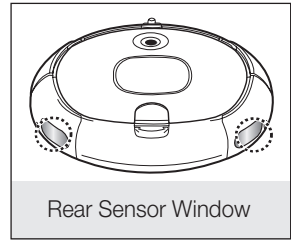
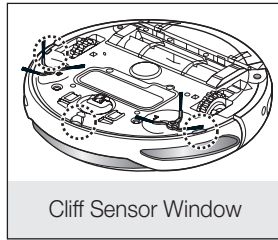
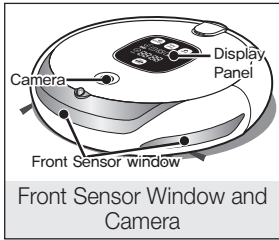
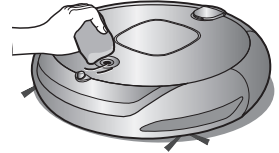

CLEANING THE ROBOTIC VACUUM CLEANER

EMPTYING DUST QUICKLY

- You can easily empty the dust bin using a normal vacuum cleaner, without separating the dust bin.

1. Open the dust outlet cover.

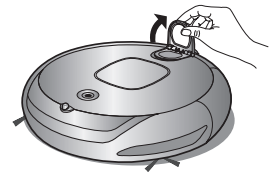

2. If you hold the air inlet of the vacuum cleaner to the dust outlet, it will vacuum the dust directly from the dust bin.

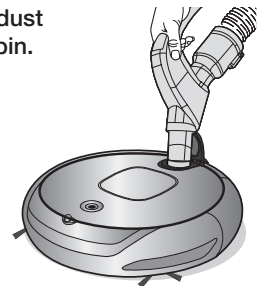

Maintain tools and filter

CLEANING THE DUST BIN AND THE FILTER

First, empty the dust bin before cleaning it.

- When separating the dust bin, take care not to spill the dust out of the dust bin.
- Empty the dust bin in the following cases.
 1. When dust has accumulated inside the dust bin.
 2. When the suction power suddenly becomes weak.
 3. When the noise suddenly increases.

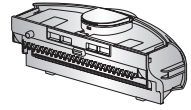

1. Press the Dust Bin Eject (PUSH) button and pull the dust bin to separate the dust bin.

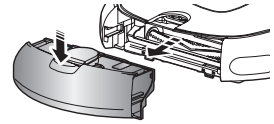

2. Separate the dust bin cover by pulling it in the direction of the arrow in the figure.

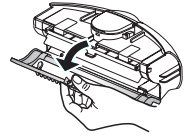

3. Separate the filter from the dust bin by pulling it in the direction of the arrow in the figure.

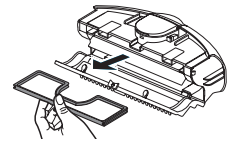

4. Wipe the dust from the filter and the dust bin.

* You can wash them with water.

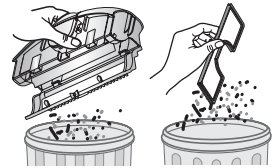

5. Install the filter into the dust bin.

- Make sure that the grid pattern of the filter is facing downwards. It cannot be installed in the wrong direction.

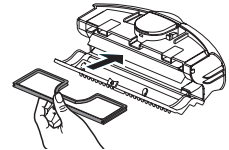

6. Close the dust bin cover and install it into the main unit.

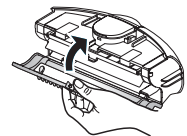

Maintain tools and filter

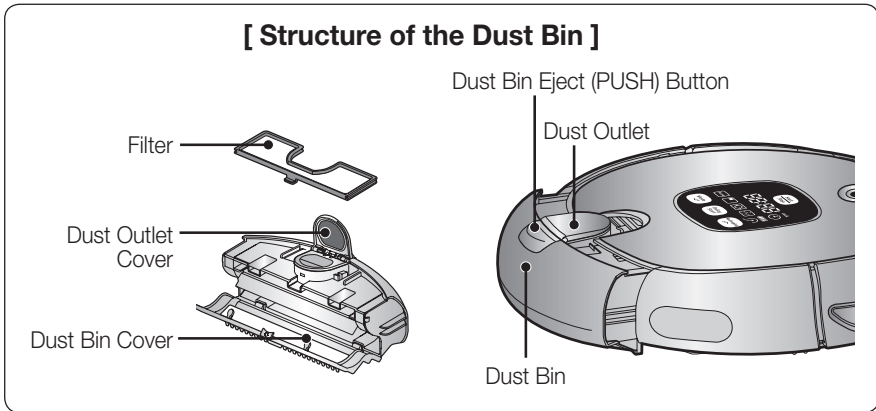

CLEANING THE ROBOTIC VACUUM CLEANER

CLEANING THE POWER BRUSH

You must turn off the Power Switch at the bottom of the main unit before cleaning the robotic vacuum.



- Because the dust in the dust bin may come out, separate the dust bin first before cleaning the power brush.

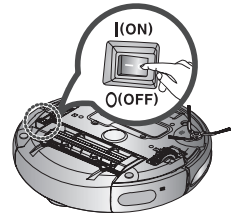

1. Separate the dust bin by pressing the Dust Bin Eject (PUSH) button.

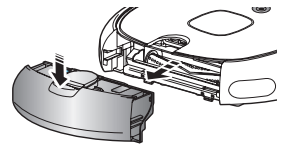

2. After checking whether there are any foreign substances, press the hook that is fixing the brush cover to separate it.

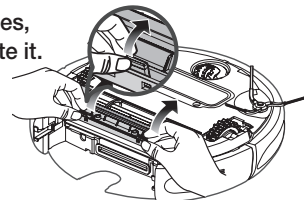

Maintain tools and filter

CLEANING THE ROBOTIC VACUUM CLEANER

3. Lift the power brush up from the main unit.

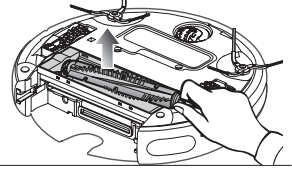

4. Remove any foreign substances such as long hairs or strings wrapped around the power brush using a cleaning brush or a vacuum cleaner.



5. When cleaning is complete, fix the Power Switch side of the power brush first and then fix the other side of the brush in the same way.

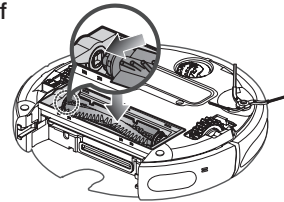

6. After inserting the 3 tips at the top of the cover, push the other end in until it “clicks” into place.

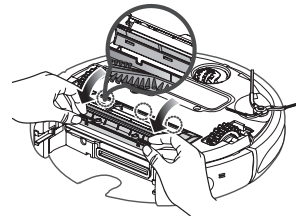

- To prevent the robotic vacuum cleaner from becoming clogged, be careful not to vacuum tooth picks or cotton swabs.
- When removing foreign substances becomes difficult, contact a customer care center.
- Because the power brush vacuums the dust on the floor, long strings or hair can become wrapped around the brush. Check and clean the power brush regularly.

Maintain tools and filter

CLEANING THE ROBOTIC VACUUM CLEANER

CLEANING THE EDGE-CLEANING SIDE ROTATING BRUSH

You must turn off the Power Switch at the bottom of the main unit before cleaning the robotic vacuum.

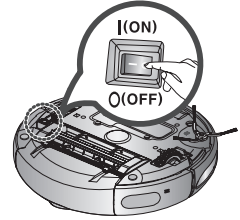

1. Check whether the side rotating brush is bent or whether there are any foreign substances stuck on the brush.

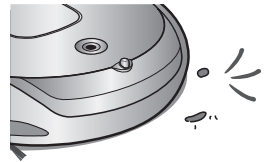

2. Wearing rubber gloves, wrap the side rotating brush with a cloth using hot water for about 10 seconds and wipe it on the cloth.

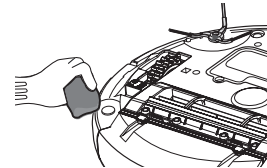

3. Turning the side rotating brush, repeat the procedures in Step 2.

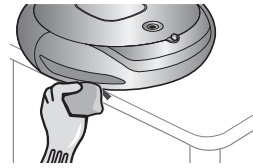

4. If hair or string is wrapped between the main unit and the side rotating brush, undo the screw of the side rotating brush using a (+) driver to remove it. When reassembling the brush, check the “L” mark on the edge-cleaning side rotating brush and the “L” mark on the main unit and then reassemble the side rotating brush.
(Letter “R” is carved at the right side rotating brush.)

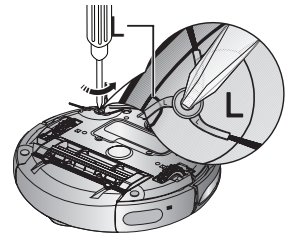

Because the side rotating brush easily attracts hair and other foreign substances, make sure to clean it frequently.

Excessive foreign substances on the side rotating brush can damage the brush.

Maintain tools and filter

CLEANING THE ROBOTIC VACUUM CLEANER

CLEANING THE DRIVING WHEEL

You must turn off the Power Switch at the bottom of the main unit before cleaning the robotic.

- If the robotic vacuum cleaner suddenly starts to zigzag, there may be foreign substances stuck on the driving wheel.

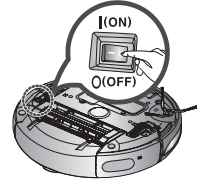

1. When cleaning the driving wheel, place a soft cloth on the floor and flip the main unit, placing it down carefully.

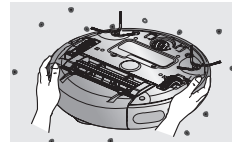

2. Check for foreign substances and remove them using a stick or a pair of blunt nippers if necessary.

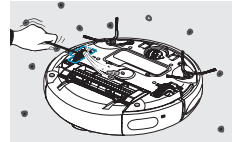

CARING FOR THE MOP (OPTION)

Since a contaminated mop may smell badly, keep the mop clean.

1. Separate the mop plate from the bottom of the cleaning robot.

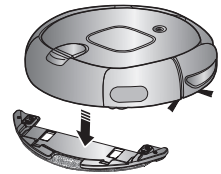

2. Remove the mop from the mop plate.

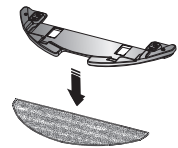

3. Wash the mop with clean water.



4. Dry the mop completely in a well-ventilated location before using it.

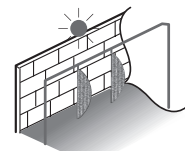

Troubleshooting

CHECKLIST BEFORE SVC CALLS

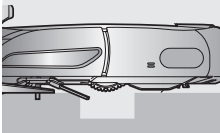
SYMPTOM	CHECKLIST	MEASURE TO TAKE
Robotic vacuum cleaner does not operate at all before cleaning.	<ul style="list-style-type: none"> • Is the dust bin assembled? • Is the Power Switch turned on? • Is cleaning mode (Auto) in the display panel turned on? • Is the battery level flashing only one level and is 'LO' displayed in the display panel? • Robotic vacuum cleaner will not operate when the battery in the remote control is depleted. 	<ul style="list-style-type: none"> • Install the dust bin. • Turn on the Power Switch. • Press the (Start/Stop) button. (To turn it off, press and hold the (Start/Stop) button down for 3 seconds or longer.) • Lift up the robotic vacuum cleaner, and manually dock the robotic vacuum onto the charger to charge it. • Replace the batteries in the remote control. (AAA type)
Robotic vacuum cleaner stopped operating while cleaning. 	<ul style="list-style-type: none"> • Is the battery level flashing only one level and is 'LO' displayed in the display panel? • Has the robotic vacuum cleaner become hooked on wires on the floor? • Is the robotic vacuum cleaner stuck to the floor where there is a height difference? <ul style="list-style-type: none"> - The driving wheel is lifted. • Is there a thin towel (cloth) wrapped around the driving wheel? • Is the robotic vacuum cleaner stuck on the doorsill? 	<ul style="list-style-type: none"> • Lift up the robotic vacuum cleaner, manually dock the robotic onto the charger to charge it. • Turn off the Power Switch and remove the wires. • Turn off the Power Switch and move the cleaning robotic vacuum to another place to clean. • Turn off the Power Switch and remove the thin towel. • Turn off the Power Switch and move the robotic vacuum cleaner to another place to clean.
The suction power is weak while cleaning.	<ul style="list-style-type: none"> • Check whether the dust bin is full of dust. • Check whether the suction inlet is clogged by foreign substances. • Check whether the filter is clogged. 	<ul style="list-style-type: none"> • Stop the robotic vacuum cleaner and empty the dust bin. • Turn off the Power Switch and remove the foreign substances on the suction inlet. • Clean the filter well.

Troubleshooting

CHECKLIST BEFORE SVC CALLS

SYMPTOM	CHECKLIST	MEASURE TO TAKE
Robotic vacuum cleaner cannot find the charger.	<ul style="list-style-type: none"> • Check whether the power plug of the charger is plugged correctly into the outlet. • If there are any obstacles within a range of about 1m in front of the charger and about 0.5m range to the left and right of the charger, you should remove the obstacles. • If there are any foreign substances on the charge pin, wipe them off with a dry towel. • Is the VIRTUAL GUARD installed near the charger? 	<ul style="list-style-type: none"> • Move the VIRTUAL GUARD to another place so that the robotic vacuum cleaner can charge automatically.
Robotic vacuum cleaner passes through the VIRTUAL GUARD.	<ul style="list-style-type: none"> • Are the batteries of the VIRTUAL GUARD worn out? • Is the VIRTUAL GUARD set to Guard (virtual door) mode? • Is the Mode lamp turned off? 	<ul style="list-style-type: none"> • Replace the batteries. (2 type D (LR20) alkaline batteries) • Set the VIRTUAL GUARD to Fence (virtual wall) mode. • Check if the VIRTUAL GUARD is turned off and then set the VIRTUAL GUARD to a desired mode.
The battery usage time of the VIRTUAL GUARD is too short.	<ul style="list-style-type: none"> • Are you using manganese drycell batteries? 	<ul style="list-style-type: none"> • Replace the batteries with new alkaline batteries. (2 type D (LR20) alkaline batteries)
In the display panel, From 30,29,28,... the number is counted down.	<ul style="list-style-type: none"> • Is the robotic vacuum cleaner forced to separate from charger or pressed during charging? 	<ul style="list-style-type: none"> • When the robotic vacuum cleaner is separated or pressed during the charging, after 30-second it returns to the charger for automatic recharging.

Troubleshooting

TROUBLESHOOTING FOR ERROR CODES



ERROR CODE	CAUSE	SOLUTION
C 00	<ul style="list-style-type: none"> Robotic vacuum cleaner is caught, stuck or trapped while navigating. 	<ul style="list-style-type: none"> Turn off the Power Switch at the bottom and move the robotic vacuum cleaner to a different location.
C 01	<ul style="list-style-type: none"> A foreign substance (string, paper, toy etc.) is caught in the power brush. 	<ul style="list-style-type: none"> Turn off the Power Switch at the bottom and remove the foreign substance from the power brush.
C 02	<ul style="list-style-type: none"> A foreign substance (string, paper, toy etc.) is caught in the left driving wheel. 	<ul style="list-style-type: none"> Turn off the Power Switch at the bottom and remove the foreign substance from the left driving wheel.
C 03	<ul style="list-style-type: none"> A foreign substance (string, paper, toy etc.) is caught in the right driving wheel. 	<ul style="list-style-type: none"> Turn off the Power Switch at the bottom and remove the foreign substance from the right driving wheel.
C 05	<ul style="list-style-type: none"> Check bumper sensor. 	<ul style="list-style-type: none"> Slightly pull the stuck bumper outward.
C 06	<ul style="list-style-type: none"> A foreign substance (dust, stain etc.) is on the Obstacle sensor window. 	<ul style="list-style-type: none"> Turn off the Power Switch at the bottom and wipe the foreign substance from the front and rear sensor windows using a soft cloth.
C 07	<ul style="list-style-type: none"> A foreign substance (Dust, stain etc.) is on the Cliff sensor window. 	<ul style="list-style-type: none"> Turn off the Power Switch at the bottom and wipe the foreign substance on the cliff sensor window with a soft cloth.
C 08	<ul style="list-style-type: none"> Dust bin not inserted. 	<ul style="list-style-type: none"> Insert the dust bin until you hear a "Click" sound.
C 09	<ul style="list-style-type: none"> A foreign substance (String, cloth etc.) is caught on the edge-cleaning side rotating brush. 	<ul style="list-style-type: none"> Turn off the Power Switch at the bottom and wipe the foreign substance from the edge-cleaning side rotating brush.

* If you press the Start/Stop button or turn off the Power Switch, the error code is cleared.

Product specification

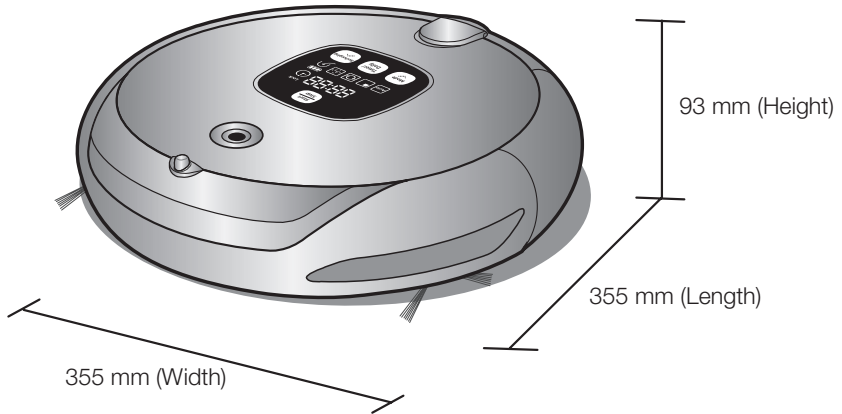

Main Body

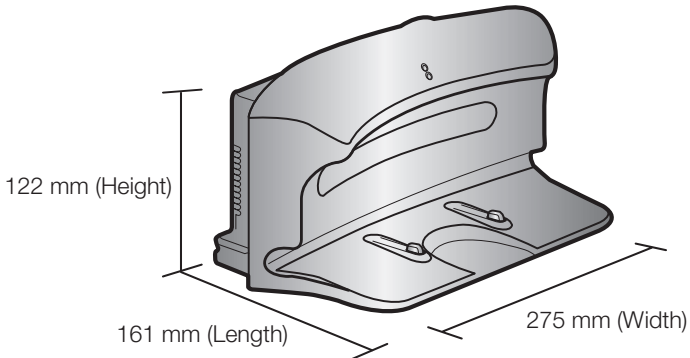

Charger(Station)

Product specification

CLASSIFICATION	ITEM	DETAIL
Mechanical Specifications	Diameter	355mm
	Height	93mm
	Weight	4.0kg
Electrical Specifications	Power voltage	AC220-240V~, 50-60Hz
	Charge power consumption	50 W
	Main unit power consumption	40 W
	Battery specifications	14.4V / 2,000 mA
Cleaning Specifications	Dust bin capacity	About 0.6 ℓ
	Charging type	Auto Charging/Manual Charging
	Cleaning mode	Auto, Spot, Max, Manual, Scheduled, Setting Daily Cleaning
	Charging time	About 120 minutes
	Cleaning time (on the basis of hard floor)	About 90 minutes
Cleaning method		Ceiling shape recognition
Main unit button type		Touch type

This Vacuum cleaner is approved the following.

Electromagnetic Compatibility Directive : 2004/108/EEC

Low Voltage Directive : 2006/95/EC





SR8894
SR8895

Robotski sesalnik Uporabniški priročnik

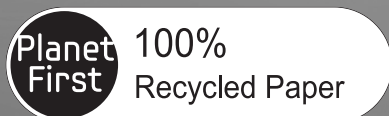

Ta priročnik je izdelan iz 100% recikliranega papirja.

- * Pred uporabo izdelka pozorno preberite navodila.
- * Samo za uporabo v zaprtih prostorih.

Slovenščina

svet novih možnosti

Zahvaljujemo se vam za nakup Samsungovega izdelka.

Če želite popolnejšo ponudbo storitev, izdelek registrirajte na

www.samsung.com/register

SAMSUNG

Varnostne informacije

VARNOSTNE INFORMACIJE



- Pred uporabo sesalnika preberite ta priročnik in ga shranite za poznejšo uporabo.



- Ker so ta navodila namenjena različnim modelom, bodo značilnosti vašega sesalnika morda drugačne od tistih v tem priročniku.

UPORABLJENA SIMBOLA ZA OPOZORILO/POZOR



Označuje nevarnost smrtnih ali hudih poškodb.



Označuje nevarnost telesnih poškodb ali materialne škode.

DRUGI UPORABLJENI SIMBOLI



Razlaga izrazov za boljše razumevanje pravilnega načina uporabe izdelka.

Varnostne informacije

POMEMBNA VARNOSTNA NAVODILA

Ko uporabljate električni aparat, upoštevajte naslednje osnovne varnostne ukrepe:

PRED UPORABO ROBOTSKEGA SESALNIKA PREBERITE VSA NAVODILA.

Ko sesalnika ne uporabljate ali pred vzdrževanjem, ga izključite iz vtičnice.

OPOZORILO: za zmanjšanje nevarnosti požara, električnega udara ali poškodb:

SPLOŠNO

- Uporabljajte samo v skladu z navodili v tem priročniku.
- Robotskega sesalnika in polnilnika ne uporabljate, če sta kakor koli poškodovana.
- Če sesalnik ne deluje ustrezno, vam je padel na tla, se je poškodoval, ste ga pustili na prostem ali vam je padel v vodo, ga vrnite centru za pomoč strankam.
- Polnilnika in robotskega sesalnika ne prijemajte z mokrimi rokami.
- Sesalnik uporabljajte samo na suhih površinah v zaprtih prostorih.
- Aparata ne smejo uporabljati osebe (in otroci) s fizičnimi, senzoričnimi in psihičnimi motnjami ter imajo premalo izkušenj in znanja, razen če jih nadzira ali jim o uporabi aparata svetuje oseba, ki je odgovorna za njihovo varnost.
- Otroke je treba nadzorovati in tako zagotoviti, da se ne igrajo z aparatom.

POLNILNIK BATERIJE

- Ne spreminjajte polariziranega vtiča tako, da se bo prilegal nepolarizirani vtičnici ali kabelskemu podaljšku.
- Sesalnika ne uporabljajte na prostem ali na mokrih površinah.
- Ko sesalnika ne uporabljate in pred servisiranjem, polnilnik izključite iz vtičnice.
- Baterijo polnite samo s polnilnikom, ki ga je priložil proizvajalec.
- Izdelka ne uporabljajte, če je kabel ali vtič poškodovan.
- Kabla ne vlecite, ne uporabljajte ga za prenašanje ali kot ročaj, ne priprite ga z vrati in ne vlecite ga okoli ostrih robov ali vogalov. Kabel ne sme priti v stik z vročimi površinami.
- Ne uporabljajte kabelskih podaljškov ali vtičnic s premajhno močjo prenosa električnega toka.
- Izdelka ne izključujte tako, da ga vlečete za kabel. Ko želite izključiti izdelek, primite za vtič, in ne za kabel.
- Ne poškodujte ali sežigajte baterij, saj pri višjih temperaturah eksplodirajo.
- Polnilnika ne poskušajte razstaviti. Popravila sme izvajati samo usposobljeni center za pomoč strankam.
- Polnilnika ne izpostavljajte visokim temperaturam in pazite, da polnilnik ne pride v stik s kakršno koli mokroto ali vlago.

Varnostne informacije

ROBOTSKI SESALNIK

- Ne sesajte trdih ali ostrih predmetov, kot so steklo, žebelji, vijaki, kovanci ipd.
- Sesalnika ne uporabljajte brez nameščenega filtra. Med servisiranjem izdelka ne vstavljajte prstov ali predmetov v prostor z ventilatorjem, saj se lahko izdelek nehote vklopi.
- Ne vstavljajte predmetov v odprtine izdelka ne uporabljajte, če je katera od odprtih blokirana. V odprtinah se ne smejo kopičiti prah, vlakna, lasje in karkoli drugega, kar bi zmanjšalo pretok zraka.
- Ne vsesavajte strupenih snovi (klorovega belila, amoniaka, čistila za odtoke itd.).
- Izdelka ne uporabljajte za sesanje predmetov, ki gorijo ali se kadijo, kot so cigarete, vžigalice in vroč pepel.
- Ne vsesavajte vnetljivih ali gorljivih tekočin, kot je bencin, in izdelka ne uporabljajte v prostorih, kjer so te tekočine lahko prisotne.
- Robotskega sesalnika ne uporabljajte v zaprtem prostoru, kjer so prisotni hlapi barv na osnovi olja, hlapi razredčil za barve, snovi za zaščito pred molji, vnetljiv prah ali drugi eksplozivni ali strupeni hlapi.
- Pri ekstremni uporabi ali ekstremnih temperaturah lahko pride do puščanja baterijskih celic. Če tekočina pride v stik s kožo, jo hitro sperite z vodo. Če tekočina pride v stik z očmi, jih takoj začnite spirati s čisto vodo in spirajte najmanj 10 minut. Poiščite zdravniško pomoč.

Kazalo

VARNOSTNE INFORMACIJE

02

- 06 Napajanje
- 07 Pred uporabo
- 10 Med uporabo
- 11 Čiščenje in vzdrževanje

ZNAČILNOSTI IZDELKA

13

- 13 Značilnosti izdelka

SESTAVA SESALNIKA

15

- 15 Sestavni deli
- 16 Ime posameznega dela

UPORABA SESALNIKA

20

- 20 Namestitev robotskega sesalnika
- 20 Vrtni red namestitve
- 20 Vklon ali izklon stikala za napajanje
- 21 Namestitev polnilnika
- 22 Polnjenje
- 23 Baterija
- 24 Nastavitev časa
- 25 Namestitev NAVIDEZNEGA ČUVAJA
- 27 Namestitev krpe za tla (možnost)
- 28 Uporaba robotskega sesalnika
- 28 Zagon/ustavitev sesanja
- 29 Polnjenje
- 30 Samodejno sesanje
- 31 Sesanje območja
- 32 Maksimalno sesanje
- 33 Ročno sesanje
- 34 Sesanje po urniku
- 35 Nastavitev dnevnega sesanja
- 36 Uporaba dodatnih funkcij (turbonačin, način sesanja robov)

VZDRŽEVANJE NASTAVKOV IN FILTRA

36

- 36 Čiščenje robotskega sesalnika
- 36 Upoštevajte načine čiščenja in vzdrževanja
- 37 Čiščenje okenca senzorja in kamere
- 37 Hitro praznjenje posode za prah
- 38 Čiščenje posode za prah in filtra
- 39 Čiščenje zmogljive krtače
- 41 Čiščenje stranske vrtljive krtače za sesanje robov
- 42 Čiščenje pogonskega kolesca
- 42 Nega krpe za tla (možnost)

ODPRAVLJANJE TEŽAV

43

- 43 Kaj je treba preveriti, preden pokličete serviserja
- 45 Odpravljanje težav z uporabo kod napak

SPECIFIKACIJE IZDELKA

46

- 46 Specifikacije izdelka

Varnostne informacije

NAPAJANJE



Ne prepegibajte napajalnega kabla ali nanj postavljajte težkih predmetov, ki bi ga lahko poškodovali.

– To lahko povzroči požar ali električni udar.

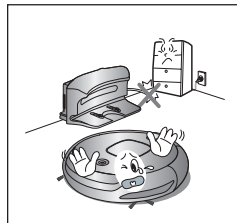

Z napajalnega vtiča odstranite morebitni prah ali vodo.

– Sicer lahko pride do okvare ali električnega udara.

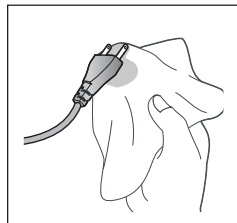

Napajalnega vtiča ne vlecite za kabel ali ga prijemajte z mokrimi rokami.

– To lahko povzroči požar ali električni udar.

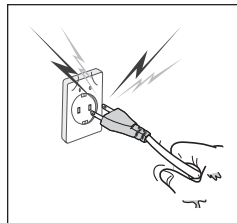

V eni vtičnici ne uporabljajte več vtičev. (Kabla ne pustite ležati nezaščitenega na tleh.)

– To lahko povzroči požar ali električni udar.

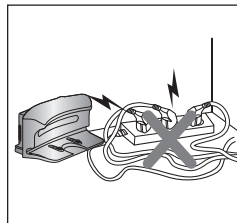

Ne uporabljajte poškodovanega napajalnega kabla, vtiča ali zrahljane napajalne vtičnice.

– To lahko povzroči požar ali električni udar.

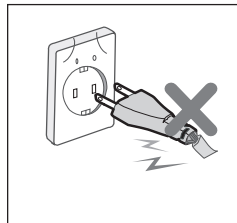

Varnostne informacije

PRED UPORABO



Pred uporabo robotskega sesalnika se prepričajte, da je posoda za prah sestavljena.

- Če posoda za prah ni nameščena, robotski sesalnik ne bo deloval.

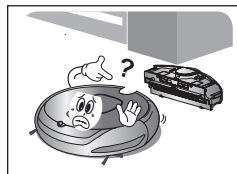

Robotskega sesalnika ne uporabljajte v prostorih z vnetljivimi materiali, kot so:

- Prostori, kjer so na tleh sveče ali namizne svetilke.
- Prostori z nenadzorovanim gorenjem (ogonj ali ogorki).
- Prostori, v katerih so bencin, destiliran alkohol, razredčilo, pepelniki s prižganimi cigaretami itd.

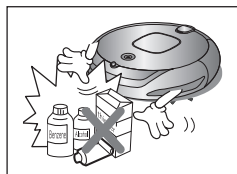

Robotski sesalnik je namenjen samo za domačo uporabo. Ne uporabljajte ga v naslednjih prostorih.

- Na podstrešjih, v kletih, skladiščih, industrijskih zgradbah, prostorih, ločenih od glavne zgradbe, prostorih, izpostavljenih vodi ali vlagi, kot so kopalnice ali pralnice, ter na ozkih in visokih mestih, kot so mize ali police. Pri uporabi na takšnih mestih lahko pride do nepravilnega delovanja ali resnih poškodb izdelka.



Odprite vsa vrata, da posesate vse prostore.

- Če so vrata zaprta, robotski sesalnik ne more posesati prostora.
- Vendar ne pozabite zapreti vrat glavnega vhoda, balkona in kopalnice ter vseh ostalih prostorov, kjer bi robotski sesalnik lahko padel v nižje nadstropje.



Če imajo preproge dolge rese, jih umaknite pod preprogo.

- Če rese niso umaknjene, se lahko zataknejo v pogonsko kolesce ali zmogljivo krtačo, zaradi česar se lahko resno poškoduje preproga ali sesalnik.

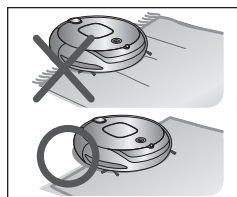

Če je senzor za stopnice umazan, lahko robotski sesalnik pade po stopnicah.

To lahko povzroči telesne poškodbe in resne poškodbe izdelka.

Da preprečite tveganje, namestite NAVIDEZNE ČUVAJE (nastavitev načina Fence (Ograja)) pred nevarna območja. Očistite okence senzorja in kamero.

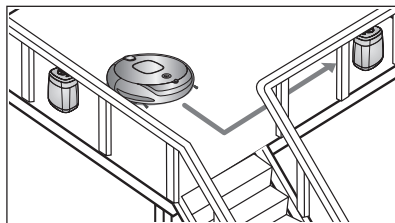

Varnostne informacije

PRED UPORABO



Preden začnete sesati prostor, odstranite manjše in lomljive predmete.

- Pred sesanjem se prepričajte, da ste odstranili vse predmete.
- Prepričajte se, da ste odstranili vse lomljive predmete, kot so predmeti iz porcelana in stekla, cvetlične posode itd.
- Robotski sesalnik ne prepozna kovancev, prstanov ali drugih dragocenih predmetov, kot je nakit.

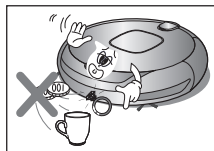

Pred sesanjem odstranite vse predmete, ki so razmetani po tleh.

- Robotski sesalnik je zasnovan tako, da zazna ovire v oddaljenosti 5 cm.
- Kopalniške brisače, preproge pred tuši in lijak, vhodi, pralnicami, napajalni kablji, namizni prtji ali pasovi se lahko zapletejo v pogonsko kolesce ali zmogljivo krtačo. To lahko povzroči, da predmeti padejo z mize.

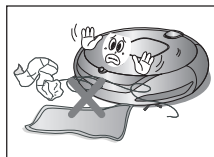

Vse člane družine (ali osebe, ki jih zadeva sesanje) pred sesanjem ali uporabo načina sesanja po urniku opozorite, naj bodo pozorni.

- Robotski sesalnik se lahko zadane v otroke, zaradi česar lahko padejo.

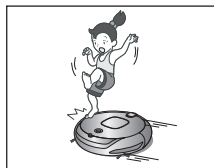

Zagotovite, da otroci robotskega sesalnika ne bodo pohodili ali se nanj usedli.

- Otroci lahko padejo in se poškodujejo ali pa lahko pride do resnih poškodb izdelka.



Ko je otrok ali hišni ljubljencec sam doma, se prepričajte, da ste izklopili stikalo za napajanje na robotskem sesalniku.

- Robotski sesalnik bo morda pritegnil njihovo pozornost.
- Če se v vrtljivo kolesce ali krtačo zataknejo prsti, noge, obleka ali lasje, lahko pride do telesnih poškodb.
- Če otrok ali hišni ljubljencec ovirata robotski sesalnik, ju ta lahko zazna kot oviro in območje morda ne bo posesano.
- Če je stikalo za napajanje izklopljeno, je napajanje izključeno in vse funkcije so onemogočene.

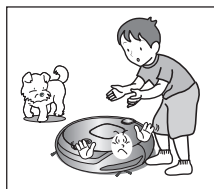

Pri nameščanju polnilne postaje ne pustite napajalnega kabla izpostavljenega na tleh.

- Ko se robotski sesalnik samodejno polni ali gre mimo polnilnika, lahko povleče napajalni kabel za seboj.

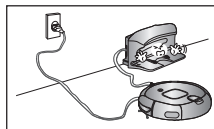

Napajalni kabel polnilnika naj bo vedno priključen na vtičnico.

- Čeprav ima robotski sesalnik funkcijo samodejnega polnjenja, ne more samodejno polniti baterije, če je napajalni kabel polnilnika izključen.

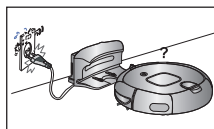

Varnostne informacije

PRED UPORABO



POZOR

Polnilnik namestite na mesto, kjer bo robotski sesalnik zlahka dostopal do njega.

- Če polnilnik namestite v vogal, lahko pride do dodatnih premikov, kar lahko zmoti proces samodejnega polnjenja.

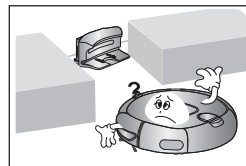

POZOR

Če se pred polnilnikom nahajajo predmeti, se robotski sesalnik ne more samodejno polniti.

- Odstranite morebitne predmete.

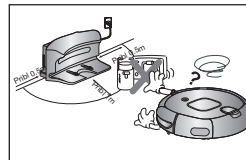

OPOZORILO

Poskrbite, da 0,5 m levo in desno od polnilnika ter 1 m pred njim ni ovir.

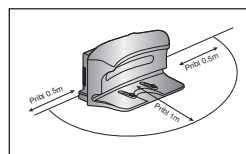

OPOZORILO

V vtiče za polnjenje ne vstavljajte kovinskih predmetov, kot so kitajske paličice, izvijači itd.

- To lahko resno poškoduje polnilnik.

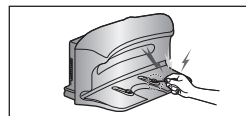

OPOZORILO

Poskrbite, da na polnilni postaji ni tekočine.

- Sicer lahko pride do požara ali električnega udara.

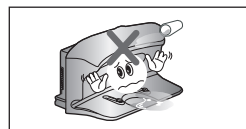

OPOZORILO

Z robotskim sesalnikom ne sesajte tekočin, kot so voda, olje in iztrebki hišnih ljubljenčkov.

- To lahko povzroči resno poškodbo izdelka.

- Tekočina se lahko raznese s kolesci in poveča umazanijo.

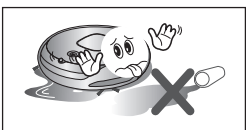

POZOR

Sesalnika ne uporabljajte na črnih tleh.

- Robotski sesalnik morda ne bo pravilno deloval.

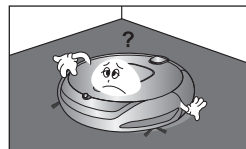

OPOZORILO

Polnilnik uporabljajte samo za polnjenje sesalnika.

- Sicer lahko pride do resnih poškodb polnilnika ali do požara.

Varnostne informacije

MED UPORABO



POZOR

Robotskega sesalnika ne smete uporabljati na debelih preprogah.

- To lahko poškoduje robotski sesalnik.
- To lahko poškoduje preproge.

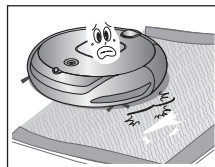

POZOR

Robotskega sesalnika ne uporabljajte za sesanje miz ali drugih visokih mest.

- Sesalnik lahko pade in se poškoduje.



POZOR

Robotski sesalnik se lahko med sesanjem zadane v pohištvo, kot so noge stolov in miz, ozko in dolgo pohištvo ipd.

- Za hitrejšo in natančnejšo sesanje stole položite na mizo.

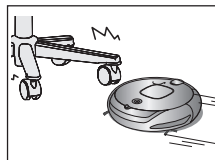

POZOR

Na robotski sesalnik ne postavljajte predmetov.

- To lahko povzroči okvaro.



POZOR

Če med sesanjem sesalnik vsesa večje kose papirja ali plastične vrečke, jih takoj odstranite.

- Če ima robotski sesalnik zamašeno sesalno odprtino in ga kljub temu uporabljate, lahko pride do resnih poškodb izdelka.

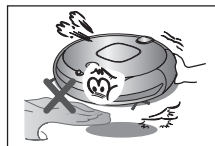

OPOZORILO

Če iz robotskega sesalnika prihaja nenavaden hrup, vonj ali dim, takoj izklopite stikalo za napajanje in pokličite center za pomoč strankam.

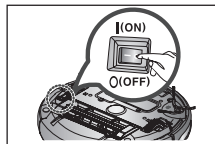

OPOMBA

Robotski sesalnik ne more nadaljevati sesanja, če ne more prečkati praga vhoda ali balkona.

- Če se robotski sesalnik ne premakne več kot 5 minut, iz varnostnih razlogov preneha delovati.
- Za ponovni zagon delovanja izklopite stikalo za napajanje, prestavite sesalnik na primerno mesto in znova vklopite stikalo.

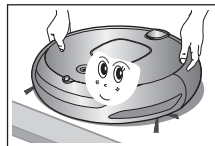

Varnostne informacije

MED UPORABO



OPOMBA **Robotski sesalnik ne more v celoti posesti težko dosegljivih mest, kot so vogali in mesta med pohištvo in stenami.**

- Ta mesta občasno počistite.

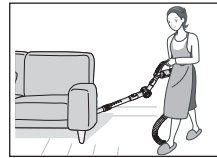

OPOMBA **Po sesanju lahko ostanejo kepice prahu, če so te nastale med sesanjem in jih robotski sesalnik ni uspel vsesati.**

- V tem primeru prah očistite z drugim pripomočkom za čiščenje.



POZOR

Ko je na robotskem sesalniku nameščena krpa za tla, se sesalnik ne more pomikati po preprogah. (možnost)

- Preden začnete čistiti preprogo, odstranite krpo za tla in nastavek zanjo.

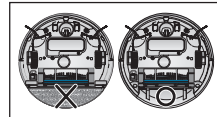

POZOR

Na izdelku ni dovoljena uporaba mokrih krp za tla. (možnost)

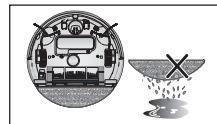

ČIŠČENJE IN VZDRŽEVANJE



POZOR

Če želite očistiti sesalnik, ohišja ne škropite neposredno z vodo in ga brišite z vnetljivimi sredstvi, kot so bencin, razredčilo ali alkohol.

- To lahko resno poškoduje izdelek.

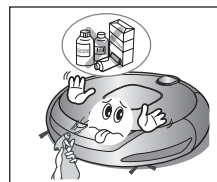

POZOR

Na odbijača robotskem sesalniku ne pritiskajte s silo.

- Če se senzor odbijača poškoduje, lahko robotski sesalnik udarja ob stene ali pohištvo.

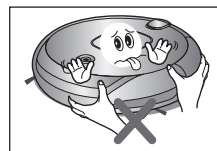

POZOR

Izdelek lahko razstavlja ali sestavlja samo ustrezno usposobljen servisni inženir.

- V nasprotnem primeru lahko pride do poškodbe izdelka.



Varnostne informacije

ČIŠČENJE IN VZDRŽEVANJE



OPOZORILO

Redno čistite nečistočo, ki se nabere na senzorjih za ovire in stopnice.

- Nesnaga, ki se je nakopičila na senzorjih, povzroči, da senzorji ne delujejo pravilno.

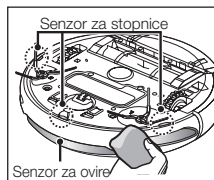

OPOZORILO

Ko odstranjujete morebitne tujke, najprej izklopite stikalo za napajanje in nato uporabite čistilno krtačo.

- Če tega ne upoštevate, se izdelek lahko nenadoma vklopi in povzroči telesne poškodbe ali resne poškodbe izdelka.

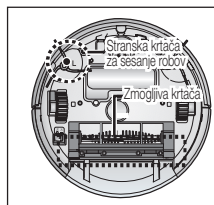

OPOZORILO

Če je napajalni kabel poškodovan, naj vam ga zamenja usposobljeni servisni inženir iz centra za pomoč strankam.

- Sicer lahko pride do požara ali električnega udara.



OPOZORILO

Pred čiščenjem polnilnika iz varnostnih razlogov izključite napajalni kabel.



OPOZORILO

Po čiščenju krpo za tla operite in jo pred naslednjo uporabo popolnoma posušite. (možnost)

- Sicer lahko pride do neprijetnih vonjav.

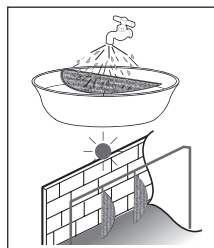

OPOZORILO

Če želite zamenjati baterijo, se obrnite na center za pomoč strankam družbe Samsung Electronics.

- Uporaba neoriginalnih baterij povzroči okvaro izdelka.

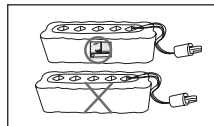

Značilnosti izdelka

PRIROČNA FUNKCIJA NAVIDEZNEGA ČUVAJA

Robotski sesalnik lahko omejite na določeno območje tako, da uporabite način Fence (Ograja; navidezna stena), ali posesate več območij enega za drugim z uporabo načina Guard (Čuvaj; navidezna vrata).



• Kaj je prepoznavanje oblike stropa (Visionary mapping™)?

Ta funkcija s kamero na vrhu sesalnika prepozna obliko stropa, da določi območje sesanja in izdela najboljši način sesanja vseh območij tal.

TEMELJITO SESANJE VSEH VOGALOV

Ker robotski sesalnik omogoča zaporedno sesanje tal (🌀) po načrtu, ki ga določi funkcija prepoznavanja oblike stropa, posesa vse vogale v prostoru.

RAZLIČNI NAČINI SESANJA

Različni načini sesanja zadovoljijo vse vaše želje.

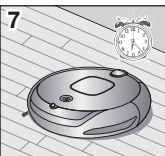
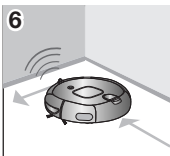
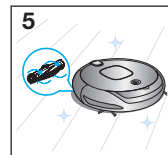
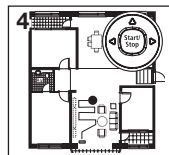
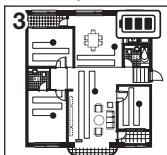
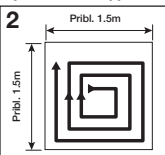
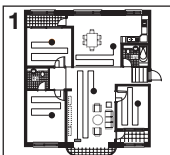

- 1. Način samodejnega sesanja :** Samodejno sesanje vseh prostorov.
- 2. NAČIN SESANJA OBMOČJA :** Temeljito sesanje določenega območja. Lahko se uporablja za sesanje drobtinic kruha ali piškotov.

- 3. Način maksimalnega sesanja :** Sesalnik deluje, dokler baterija ni skoraj izpraznjena.
- 4. Način ročnega sesanja :** Tla lahko sesate ročno tako, da premikate robotski sesalnik.
- 5. Turbonačin :** V tem načinu se zmogljiva vrtača vrti z največjo hitrostjo, zato sesalnik učinkoviteje čisti (način lahko vklopite z daljinskim upravljalnikom).
- 6. Način sesanja robov :** Ko senzor za ovire med sesanjem zazna oviro, robotski sesalnik zmanjša hitrost in skupaj s senzorjem odbijača ublaži udarec. Tako sesalnik posesa vogale kolikor daleč lahko seže.
- 7. Način sesanja po urniku :** Robotski sesalnik posesa tla ob določenem času.
- 8. Način dnevnega sesanja :** Robotski sesalnik posesa tla vsak dan ob določenem času.

ENOSTAVNO PRAZNIENJE POSODE ZA PRAH

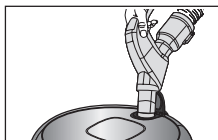

Odprtina za prah na vrhu sesalnika omogoča enostavno praznjenje posode za prah z običajnim sesalnikom, brez stresanja prahu.

Značilnosti izdelka

SAMODEJNO POLNJENJE

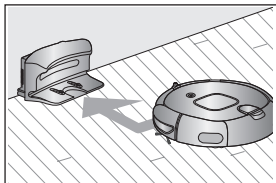

Ko je stanje baterije nizko, je robotski sesalnik samodejno usmerjen proti polnilniku, da se izvede hitro samodejno polnjenje.

STRANSKA VRTLJIVA KRTAČA ZA SESANJE ROBOV

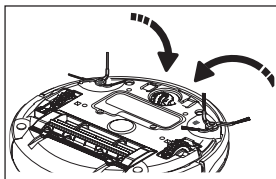

Stranska vrtljiva krtača za sesanje robov čisti prah na robovih.

PREČKANJE PRAGA

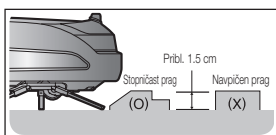

Inovativni pogonski sistem robotskega sesalnika omogoča prečkanje 1.5 cm visokih pragov in tako sesanje vseh prostorov. Robotski sesalnik morda ne bo mogel prečkati 1,5 cm praga, odvisno od njegove oblike.

SISTEM PREPREČEVANJA TRČENJ

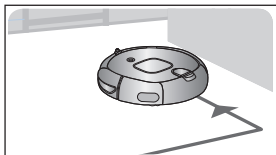

Robotski sesalnik zazna in se izogne oviram v 2 fazah. Najprej 8 senzorjev za ovire zazna ovire in če se robotski sesalnik zaleti vanje, 2 senzorja odbijača ublažita udarec.

SISTEM PREPREČEVANJA PADCEV

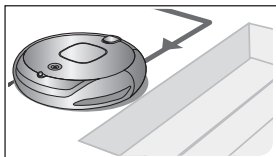

3 senzorji za stopnice zaznajo stopnice ali hišni prag, kar preprečuje, da bi robotski sesalnik padel po stopnicah.

VARNOSTNA NAPRAVA

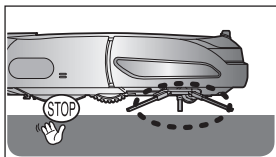

Če med sesanjem robotski sesalnik dvignete, senzor samodejno ustavi pogonska kolesca, zmogljivo krtačo, motor sesalnika in stransko vrtljivo krtačo.

Sestava sesalnika

SESTAVNI DELI



■ Osrednji del

■ Daljinski upravljalnik

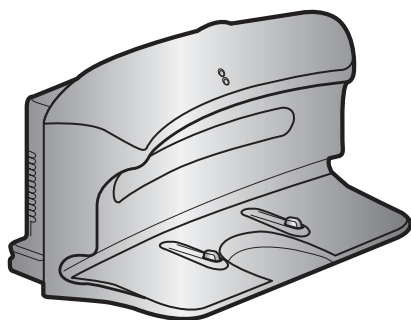

■ Polnilnik (postaja)

■ Drugi sestavni deli

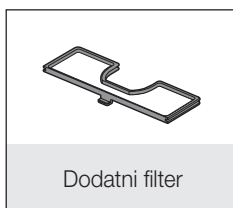
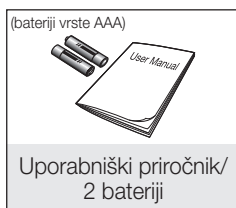

Sestava sesalnika

IME POSAMEZNEGA DELA

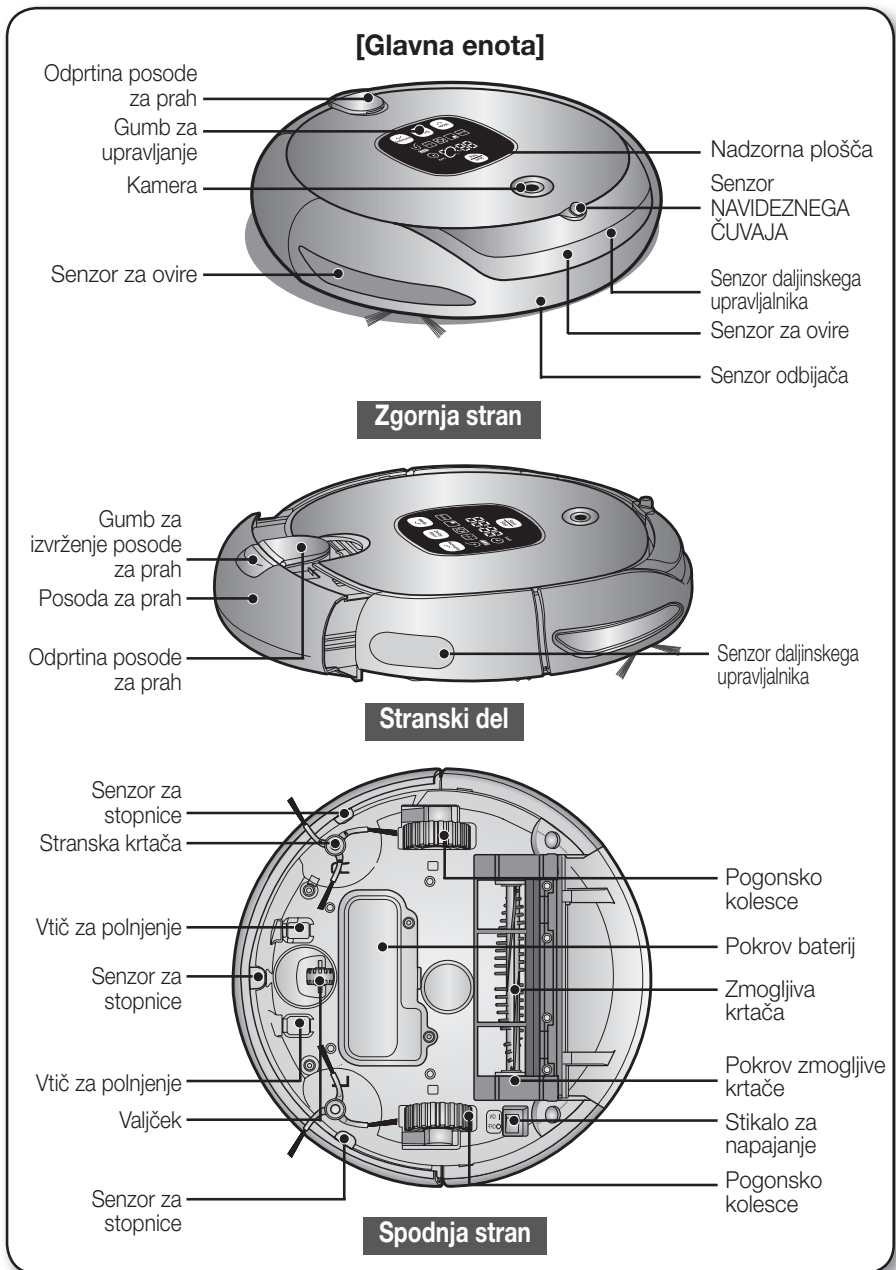

Sestava sesalnika

IME POSAMEZNEGA DELA

[Polnilnik (postaja)]

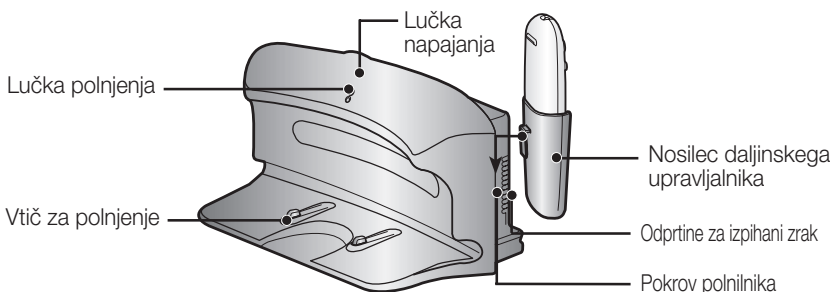

[NAVIDEZNI ČUVAJ]

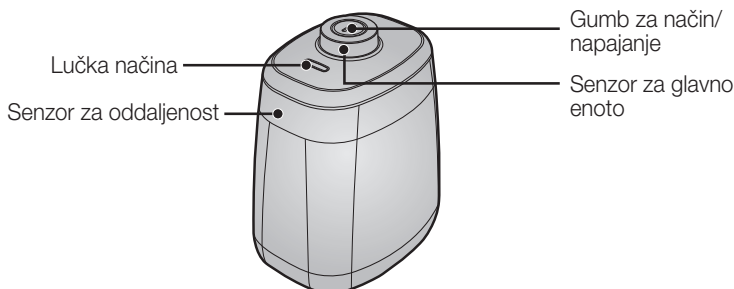

■ Namestitev baterij

Baterije niso priložene izdelku. Baterije je treba kupiti ločeno. Pred uporabo vstavite alkalni bateriji (vrste D).

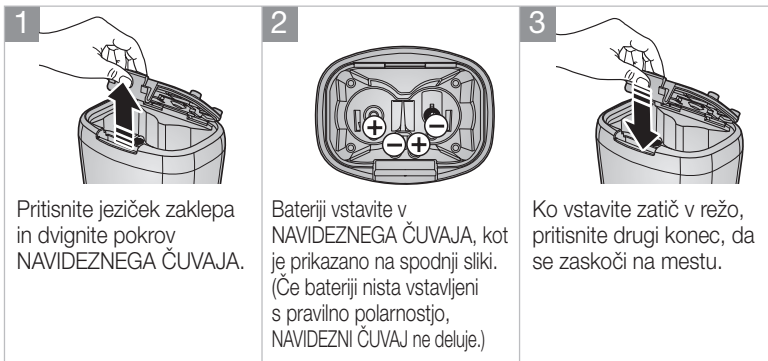

* Specifikacije: alkalne baterije vrste D (LR20)

Sestava sesalnika

IME POSAMEZNEGA DELA

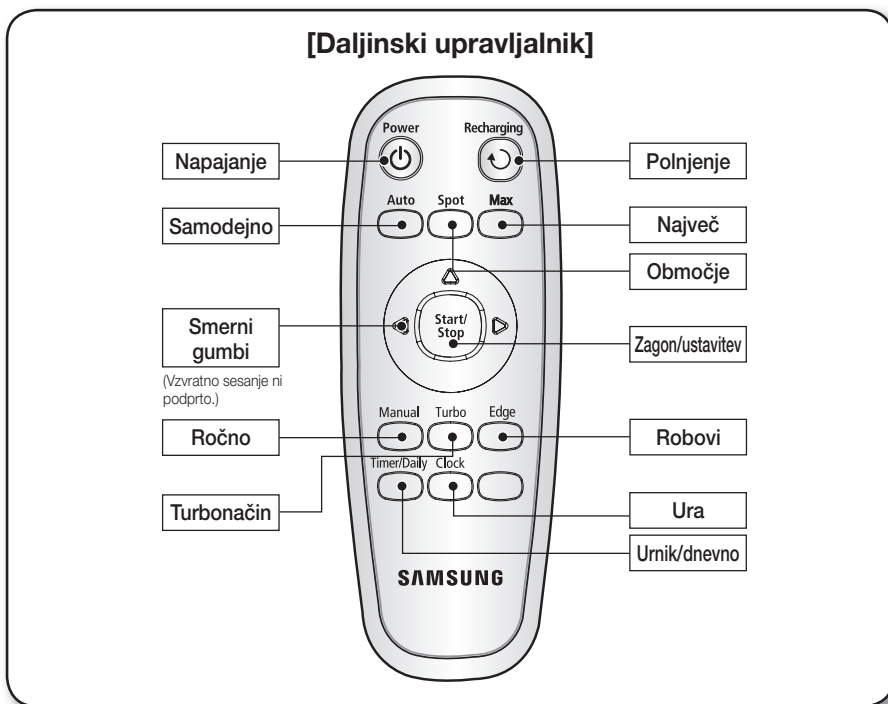

■ Namestitev baterij

Ob nakupu izdelka baterije niso nameščene v daljinskem upravljalniku. Pred uporabo vstavite baterije (vrsta AAA).



* Specifikacije: baterije vrste AAA

Sestava sesalnika

IME POSAMEZNEGA DELA

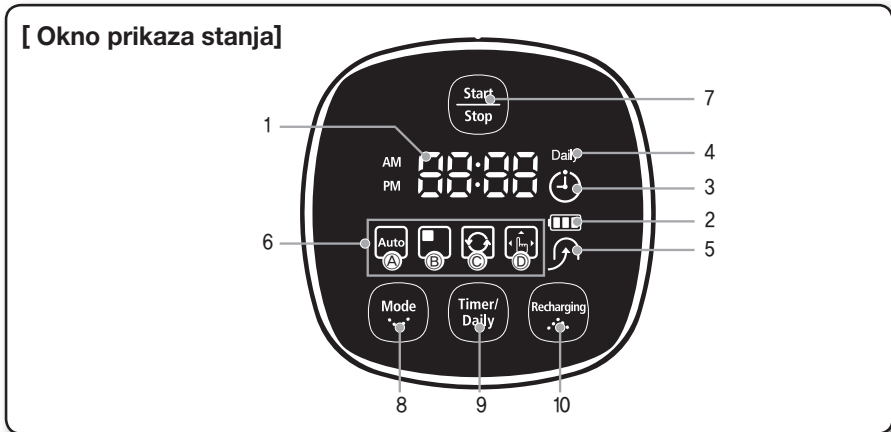

ZASLON

1. Zaslون s številkami

– Prikaz časovnika, stanja napredka in kod napak s številkami, črkami in grafiko.

2. Indikator stanja baterije

– Polnjenje: prikaz procesa polnjenja v 3 korakih.

– Med uporabo: prikaz stanja napoljenosti baterije. Med delovanjem se napoljenost baterije postopno znižuje od stanja polne napoljenosti (FULL). (Ko je baterija popolnoma izpraznjena, utripa raven za prikaz nizkega stanja baterije "LO".)

3. Sesanje po urniku

– Če izberete način sesanja po urniku, sveti ikona za sesanje po urniku.

4. Dnevno sesanje

– Če izberete način dnevnega sesanja, sveti ikona za dnevno sesanje.

5. Polnjenje

– Ta ikona sveti, ko se robotski sesalnik vrne do polnilne postaje na polnjenje baterije.

6. Zaslون načina sesanja

– Ko pritisnete gumb za način sesanja, se prikaže ustrezen način sesanja.

(a) Način samodejnega sesanja: ikona se vklopi, ko izberete način samodejnega sesanja.

(b) Način sesanja območja: ikona se vklopi, ko izberete način sesanja območja.

(c) Način maksimalnega sesanja: ikona se vklopi, ko izberete način maksimalnega sesanja.

(d) Način ročnega sesanja: ikona se vklopi, ko izberete način ročnega sesanja.

GUMBI

7. Start/Stop (Zagon/ustavitev)

– Pritisnite za zagon/ustavitev sesanja.

8. Način sesanja

– Pritisnite za izbiro načina sesanja. Ko izberete način sesanja, pritisnite gumb () za zagon sesanja.

9. Timer/Daily (Sesanje po urniku/dnevno sesanje)

– Pritisnite za izbiro sesanja po urniku ali dnevnega sesanja.

10. Recharging (Polnjenje)

– Ko pritisnete ta gumb, zasveti ikona Recharging (Polnjenje) in robotski sesalnik se vrne do polnilne postaje na polnjenje baterije.

Uporaba sesalnika

NAMESTITEV ROBOTSKEGA SESALNIKA

VRSTNI RED NAMESTITVE

1. Vkllop ali izkllop stikala za napajanje

Za uporabo robotskega sesalnika vklopite stikalo za napajanje na dnu glavne enote.

2. Namestitev polnilnika

Za polnjenje robotskega sesalnika najprej namestite polnilnik.

Ob nakupu izdelka je baterija prazna, zato morate pred uporabo sesalnika baterijo polno napolniti.

3. Polnjenje baterije

Pred uporabo robotskega sesalnika morate baterijo popolnoma napolniti.

4. Nastavitev časa

Za uporabo možnosti sesanja po urniku in dnevnega sesanja nastavite čas.

5. Namestitev NAVIDEZNEGA ČUVAJA

Robotski sesalnik lahko omejite na določeno območje tako, da uporabite način Fence (Ograja; navidezna stena), ali posestate več območij enega za drugim z uporabo načina Guard (Čuvaj; navidezna vrata).

6. Namestitev krpe za tla

Krpo za tla namestite na spodnjo stran robotskega sesalnika.



VKLOP ALI IZKLOP STIKALA ZA NAPAЈANJE

Za uporabo robotskega sesalnika vklopite stikalo za napajanje.

Če izklopite stikalo za napajanje, se vse nastavitve ponastavijo.

1. Obrnite glavno enoto in vklopite stikalo za napajanje.

- Če ikone ne svetijo, to pomeni, da je baterija prazna. V tem primeru vklopite stikalo za napajanje in robotski sesalnik namestite na polnilno postajo.
- Nastavljeni čas bo morda drugačen od trenutnega časa. Če je nastavljeni čas napačen, ga nastavite na trenutni čas.

* Če približno 5 minut po vklopu napajanja ne pritisnete nobenega gumba, se napajanje samodejno izklopi, da ne pride do izpraznitve baterije.

Napajanje znova vklopite tako, da pritisnete in kratek čas držite gumb za napajanje (Start/Stop (Zagon/ustavitev)) na glavni enoti ali na daljinskem upravljalniku.

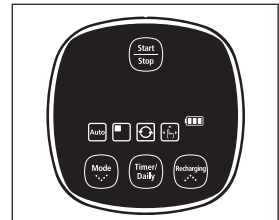
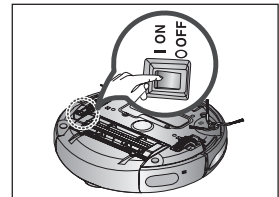

Če je gumb za napajanje izklopljen, se robotski sesalnik ne polni tudi, če je priključen na polnilnik.

Uporaba sesalnika

NAMESTITEV ROBOTSKEGA SESALNIKA

NAMESTITEV POLNILNIKA

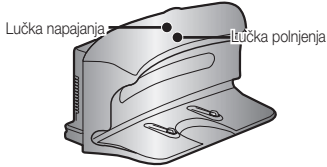

1. Polnilnik namestite na ravno površino.

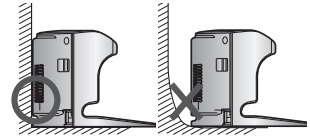

2. Poskrbite, da 0,5 m levo in desno od polnilnika ter 1 m pred njim ni ovir.

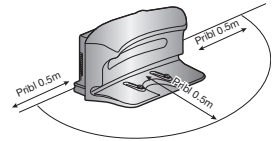

3. Polnilnik namestite na mesto, kjer bo robotski sesalnik zlahka dostopal do njega.



4. Napajalni kabel speljite ob steni.

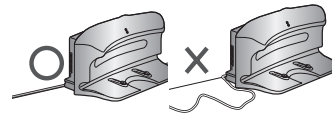

5. Če so tla lesena, namestite polnilnik v enaki smeri, kot so položena tla.

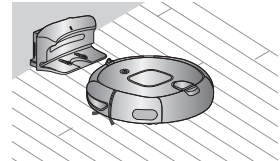

Napajalni kabel polnilnika naj bo vedno vključen v napajalno vtičnico.

- Če polnilnik ni priključen na napajanje, robotski sesalnik ne zazna polnilnika in se ne more samodejno polniti.
- Če je robotski sesalnik ni priključen na polnilnik, se baterija samodejno prazni.

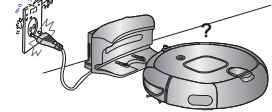

Uporaba sesalnika

NAMESTITEV ROBOTSKEGA SESALNIKA

POLNJENJE

Ob nakupu izdelka je baterija popolnoma prazna, zato morate robotski sesalnik napolniti ročno.

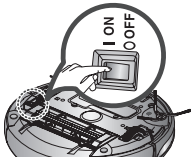

Vklopite stikalo za napajanje na spodnji strani robotskega sesalnika.

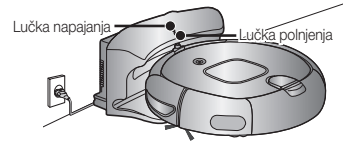

1. Ko poravnate vtiče za polnjenje na glavni enoti z vtičem za polnjenje na polnilni enoti, vstavite glavno enoto, dokler iz polnilnika ne zaslišite zvoka "polnjenja".

– Lučka polnjenja sveti zeleno.

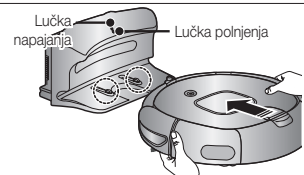

2. Preverite stanje napoljenosti robotskega sesalnika.

- Ko se napajanje začne, se na nadzorni plošči v zaporedju prikaže indikator stanja baterije in "8".
- Ko se napajanje konča, se na nadzorni plošči v zaporedju prikaže indikator stanja baterije in oznaka "FULL" (Polno).

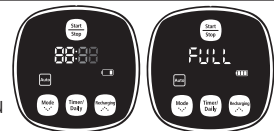

Polnjenje

Polno napolnjena baterija

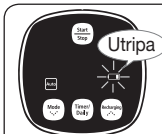

- Če med sesanjem zaslon stanja baterije utripa, robotski sesalnik preneha čistiti in se samodejno napolni na polnilniku.

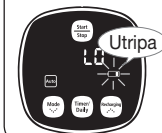

- Če med sesanjem zaslon stanja baterije utripa in se prikaže oznaka "LO", robotskega sesalnika ni mogoče upravljati z daljinskim upravljalnikom ali gumbi na glavni enoti. V tem primeru odnesite robotski sesalnik do polnilnika, da napolnite baterijo. (Če je baterija popolnoma izpraznjena.)

<Zaslon polnjenja>



OPOMBA

- Ob nakupu izdelka bo prvo polnjenje baterije trajalo približno 120 minut, baterija pa bo delovala približno 90 minut.
- Polnjenje pregrete baterije lahko poveča čas polnjenja.
- Ukrepi, ko polnjenje ni ustrezno.
Ko samodejno polnjenje robotskega sesalnika ni mogoče, preverite naslednje:
 - Izklopite in vklopite stikalo za napajanje na spodnji strani robotskega sesalnika (ponastavitev).
 - Znova priključite napajanje (ponastavitev).
 - Preverite, ali se na priključek polnilca ujeli morebitni tujki, ter priključek polnilca na glavni enoti in polnilec obrišite s suho krpo.
 - Preverite, ali se poleg polnilnika nahajajo predmeti, ki motijo polnjenje baterije.
- Ko robotski sesalnik vzamete s polnilnika, se baterija začne prazniti.
 - Zato imejte robotski sesalnik po možnosti na polnilniku. (Če zapustite dom za daljši čas, ker se na primer odpravite na poslovno pot, potovanje itd., izklopite stikalo za napajanje na robotskem sesalniku in izključite polnilnik ter obe enoti shranite.)

Uporaba sesalnika

NAMESTITEV ROBOTSKEGA SESALNIKA

BATERIJA

- Robotski sesalnik je opremljen z okolju prijazno sekundarno nikelj-metal-hidridno baterijo (NiMH), funkcija za preprečevanje prekomernega polnjenja pa zagotavlja dolgo življenjsko dobo baterije.
- **Garancijska doba baterije je 6 mesecev od datuma nakupa.**
- Ob nakupu baterije od centra za pomoč strankam zahtevajte simbol izvirnega dela () in številko modela.

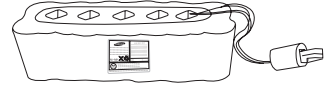

- Ta baterija je namenjena samo Samsungovim robotskim sesalnikom. Uporaba za druge naprave ali namene je strogo prepovedana.
- Baterije ne razstavljajte ali spreminjajte.
- Baterijo polnite v dobro prezračenem prostoru.
- Baterije ne izpostavljajte ognju ali jo segrevajte.
- Polov (+) ali (-) ne povežite s kakršnimi koli kovinskimi predmeti.
- Baterijo hranite v zaprtem prostoru (0 °C–40 °C).
- Preden izdelek zavržete, baterije zavržite na okolju prijazen način.
- Baterij ne zavržite med običajne gospodinjske odpadke.
- Stare baterije zavržite v skladu z lokalnimi predpisi.

- * Če baterija ne deluje, je ne razstavljajte. Obrnite se na najbližji center za pomoč strankam.
- * Daljši čas polnjenja in kratek čas napoljenosti kažeta na bližanje konca življenjske dobe baterije. Za zamenjavo baterije se obrnite na pooblaščen center za pomoč strankam.

Sekundarne baterije, ki je priložena temu izdelku, uporabnik ne more zamenjati sam. Za informacije o zamenjavi baterije se obrnite na vašega ponudnika storitev.

Uporaba sesalnika









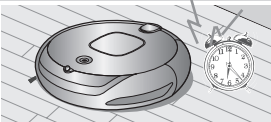

NAMESTITEV ROBOTSKEGA SESALNIKA

NASTAVITEV ČASA

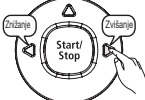
Za pravilno delovanje funkcij sesanja po urniku in dnevnega sesanja je treba nastaviti uro.

Uro je mogoče nastaviti samo z daljinskim upravljalnikom.

■ Čas je mogoče nastaviti samo z daljinskim upravljalnikom.

	Daljinski upravljalnik	Vrstni red nastavitve
 <p>Primer. Trenutni čas je 07:00</p> 		1 Vnesite trenutno "uro".
		2 Preklopite v način nastavitve.
		3 Nastavite "uro".
		4 Nastavite trenutne "minute".
		5 Končajte nastavev.

- Za nastavev ure izhoda iz načina nastavitve časa pritisnite gumb () namesto gumba za nastavev časa.

- Ko nastavite sesanje po urniku, ni več mogoče spremeniti nastavitve časa.

Uporaba sesalnika

NAMESTITEV ROBOTSKEGA SESALNIKA

NAMESTITEV NAVIDEZNEGA ČUVAJA

Robotski sesalnik lahko omejite na določeno območje tako, da uporabite način Fence (Ograja; navidezna stena), ali posesate več območij enega za drugim z uporabo načina Guard (Čuvaj; navidezna vrata).

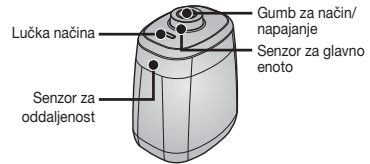

Delovanje gumbov

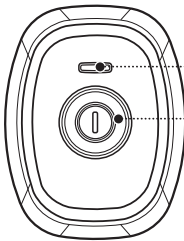

1. Delovanje lučke načina

- Način Fence (Ograja; navidezna stena): utripa rdeča lučka.
- Način Guard (Čuvaj; navidezna vrata): utripa zelena lučka.
- Off (Izklopljeno): lučka je izklopljena.

2. Nastavitev načina

- S pritiskom gumba za način/napajanje izberete način Fence (Ograja; navidezna stena) → način Guard (Čuvaj; navidezna vrata) → Off (Izklopljeno), v tem zaporedju.

* Oddaljenost navideznega zidu je najmanj 2,5M in se lahko razlikuje glede na okolico in robotovo stanje premikanja.

Ustvarjanje ograje (navidezne stene)

NAVIDEZNI ČUVAJ ustvari nevidno ogrado, ki je robotski sesalnik ne more prečkati. Npr. pred cvetličnimi posodami, pohištvom, vhodnimi vrati itd.

1. Z gumbom za način/napajanje izberite način Fence (Ograja; navidezna stena).

- Utripa rdeča lučka načina.

2. Namestite NAVIDEZNEGA ČUVAJA pred območje, do katerega želite preprečiti dostop robotskemu sesalniku.

- Namestite NAVIDEZNEGA ČUVAJA tako, da lahko senzor za oddaljenost oblikuje nevidno ogrado, ki je robotski sesalnik ne bo mogel prečkati.

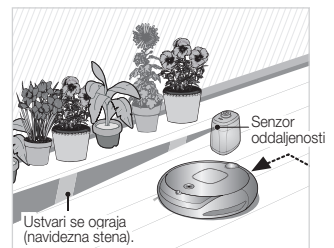

Uporaba sesalnika

Uporaba načina Guard (Čuvaj; navidezna vrata)

NAVIDEZNI ČUVAJ ustvari navidezna vrata, ki jih robotski sesalnik ne more prečkati, dokler ne poseja celotnega prostora, v katerem je trenutno. NAVIDEZNI ČUVAJ odpre navidezna vrata, ko je posesan celoten prostor.

1. Z gumbom za način/napajanje izberite način Guard (Čuvaj; navidezna vrata).

– Utripa zelena lučka načina.

2. Namestite NAVIDEZNEGA ČUVAJA ob vhodu v prostor, ki ga želite posesati.

- Namestite NAVIDEZNEGA ČUVAJA tako, da lahko senzor za oddaljenost oblikuje nevidno ogrado, ki je robotski sesalnik ne bo mogel prečkati.

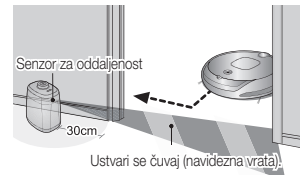
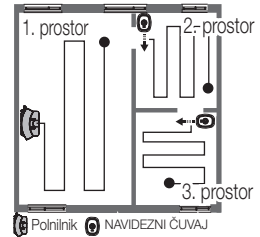

- Ko ne uporabljate NAVIDEZNEGA ČUVAJA, izklopite napajanje. (Če robotskega sesalnika dolgo časa ne uporabljate, odstranite baterije, da se ne izpraznijo.)
- Če gumb za način/napajanje ne deluje, je življenjska doba baterij potekla. V tem primeru zamenjajte baterije. (Specifikacije: alkalne baterije vrste D (LR20).)
- Dodatnega NAVIDEZNEGA ČUVAJA lahko kupite pri družbi Samsung Electronics customer care Co., Ltd.

* Ker nevidna ograda preprečuje, da bi se robotski sesalnik zaletel v NAVIDEZNEGA ČUVAJA, priporočamo, da slednjega namestite največ 30 cm od zunanje stene.



Senzor IrDA

- Prenos infrardečega signala morda ne bo nemoten v prostorih s halogenskimi žarnicami in na prostem.
- Robotski sesalnik uporablja 3 vrste infrardečih naprav, zato naprava, ki se nahaja pred prednostno napravo, morda ne bo delovala.
- Pri upravljanju robotskega sesalnika z daljinskim upravljalnikom lahko sesalnik prečka navidezno ograjo VIRTUALNEGA ČUVAJA ali se zaleti v oviro, ker ima signal daljinskega upravljalnika prednost pred signalom VIRTUALNEGA ČUVAJA.
- Pri uporabi robotskega sesalnika v majhnem prostoru ali na kratkih razdaljah, lahko pride do okvare zaradi infrardečih signalov.
- NAVIDEZNEGA ČUVAJA namestite stran od polnilnika, saj se samodejno polnjenje lahko prekine, če se NAVIDEZNI ČUVAJ nahaja blizu polnilnika.
- Če hkrati uporabljate več kot en robotski sesalnik, lahko pride do okvare zaradi infrardečih signalov.



Uporaba sesalnika

UPORABA ROBOTSKEGA SESALNIKA

NAMESTITEV KRPE ZA TLA (MOŽNOST)

Prah boste učinkovito odstranili s krpo za tla iz mikrovlaknen.

Postopek namestitve krpe za tla

1. Krpo namestite na ježek na nastavku za krpo za tla.

- Krpo za tla namestite tako, da ne pokrijete roba za namestitev krpe.

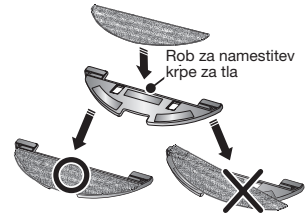

2. Poravnajte odprtini na nastavku za krpo za tla z deloma na spodnji strani robotskega sesalnika in slednja potisnite, da se zaskočita na mestu.

- Če nastavek za krpo za tla ne pritrдите v celoti, se med čiščenjem lahko sname.

* Krpo za tla namestite tako, da je poravnana z robom za namestitev krpe.

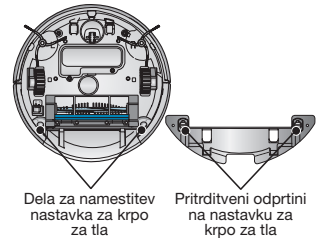

3. Položite nastavek za krpo, na katerem je nameščena krpa, na tla in ga potisnite navzdol.



- Robotski sesalnik se z nameščeno krpo za tla ne more pomikati po preprogi, zato pred čiščenjem preproge z njega odstranite krpo in nastavek zanjo.
- Po čiščenju operite umazano krpo za tla.
- Krpo za tla uporabite, ko je znova popolnoma suha. (Uporaba mokre krpe za tla ni dovoljena.)
- Če je na tleh tekočina, kot je na primer kava, je ne očistite s krpo za tla, da se umazanija ne bo raznesla po tleh.

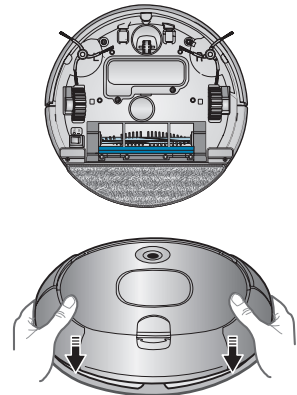

Uporaba sesalnika

UPORABA ROBOTSKEGA SESALNIKA

ZAGON/USTAVITEV SESANJA

Lahko zaženete ali ustavite vse funkcije robotskega sesalnika.

- Vsaka funkcija robotskega sesalnika deluje samo, če je stikalo za napajanje vklopljeno.
- Ko je robotski sesalnik zagnan, pritisnite gumb (Start/Stop), da prekličete delovanje in izberete zeleno funkcijo.

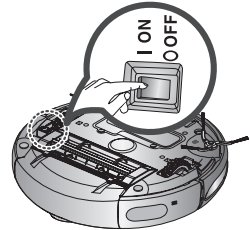

Vklop ali izklop napajanja

Vklop napajanja

- Daljinski upravljalnik: pritisnite gumb **[Power]** (Napajanje).
- Glavna enota: pritisnite gumb (Start/Stop).

Izklop napajanja

- Daljinski upravljalnik: pritisnite gumb **[Power]** (Napajanje).
- Glavna enota: pritisnite gumb (Start/Stop) in ga držite pritisnjenega 3 sekunde.

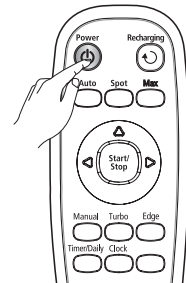

Uporaba daljinskega upravljalnika

Zagon ali ustavitev sesanja

Zagon

- Daljinski upravljalnik: pritisnite gumb Auto (Samodejno), Spot (Območje), Max (Maksimalno), Manual (Ročno).
- Glavna enota: Izberite način Auto (Samodejno)/Spot (Območje)/Max (Maksimalno)/Manual (Ročno)/ tako, da pritisnete gumb (Mode), nato pa pritisnite gumb (Start/Stop).
- Sesanje se začne tako, da se robotski sesalnik začne premikati.
- * Če pritisnete gumb (Start/Stop), brez da bi izbrali način sesanja, je izbran način samodejnega sesanja.

Ustavitev

- Za ustavitev sesanja pritisnite gumb (Start/Stop) na daljinskem upravljalniku ali glavni enoti.
- Ko sesanje ustavite, se robotski sesalnik ustavi.

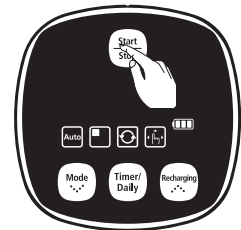

Uporaba gumbov na glavni enoti

Uporaba sesalnika

UPORABA ROBOTSKEGA SESALNIKA

POLNJENJE

Če želite, da se robotski sesalnik vrne k polnilniku in napolni baterijo, pritisnite gumb Recharging (Polnjenje).

- Ko je robotski sesalnik zagnan, pritisnite gumb (Start/Stop), da prekličete delovanje in pritisnite gumb Recharging (Polnjenje).

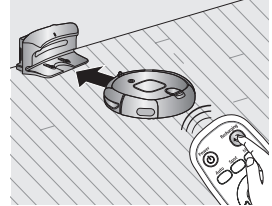

1. Pritisnite gumb Recharging (Polnjenje).

- Vklopi se ikona glavne enote (↻) in robotski sesalnik se vrne k polnilniku.

2. Če želite robotski sesalnik zaustaviti med vračanjem do polnilnika, pritisnite gumb (Start/Stop).

3. Če želite preskusiti funkcijo samodejnega polnjenja, pritisnite gumb Recharging (Polnjenje), ko je robotski sesalnik oddaljen do 1,5 m od polnilnika.

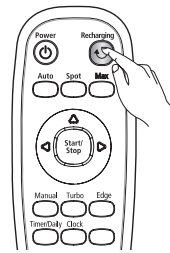

Uporaba daljinskega upravljalnika

Odpravljanje težav, ko se robotski sesalnik ne vrne k polnilniku

- Preverite namestitev polnilnika
 - Če je polnilnik nameščen na mestu, kamor ne more voditi robotskega sesalnika.
 - Če se polnilnik oddaljen več kot 5 m od robotskega sesalnika.
: V teh primerih bo robotski sesalnik morda potreboval več časa, da se vrne k polnilniku.
- Robotski sesalnik napolnite ročno v teh primerih:
 - Če je polnilnik nameščen v kotu.
 - Če je baterija popolnoma izpraznjena.
 - Če se je robotski sesalnik zagostil v oviro (npr. pohištvo itd.).
 - Če robotski sesalnik ne more prečkati praga, da bi dosegel mesto, kjer je nameščen polnilnik.

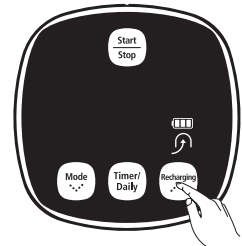

Uporaba gumbov na glavni enoti

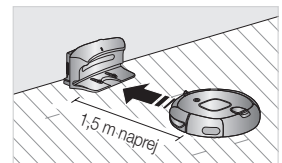

Uporaba sesalnika

UPORABA ROBOTSKEGA SESALNIKA

SAMODEJNO SESANJE

Robotski sesalnik se samodejno premika in sesa, dokler niso posesani vsi prostori.

- Če se sesanje začne, ko je robotski sesalnik priključen na polnilnik, se sesalnik hitreje vrne k polnilniku, saj si med sesanjem zapomni svoje prvotno mesto.
- Če je stanje baterije med sesanjem prenizko, se robotski sesalnik samodejno vrne k polnilniku in nadaljuje sesanje po polnjenju. (Nadaljevanje sesanja: enkrat)

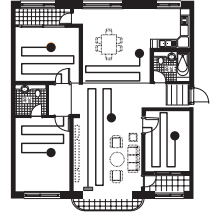

Gumb glavne enote	Gumb daljinskega upravljalnika	Vrstni red nastavitve
		1 Nastavite način.
		2 Preključite način.

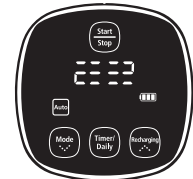

Navadni način

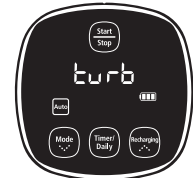

Turbonačin



Način sesanja robov



Čiščenje končano



Funkcija nadaljevanja sesanja

- Če robotski sesalnik oceni, da je sesanje končano, se funkcija nadaljevanja sesanja ne izvede.
- Če robotski sesalnik med polnjenjem prestavite ali pritisnete gumb, sesalnik oceni konec sesanja in ne nadaljuje sesanja.
- Robotskega sesalnika med sesanjem ne prestavljajte ali pritiskajte gumbov. V tem primeru sesalnik oceni, da je sesanje zaključeno in začne čistiti od začetka.
- Ko pritisnete gumb Turbo na daljinskem upravljalniku, se na zaslonu začne izmenično prikazovati On turbo (08 88 8888 ; Turbonačin vklopljen) in Off turbo (08 88 88 8888 ; Turbonačin izklopljen). Ko je prikazano On turbo (Turbonačin vklopljen), lahko tla čistite v turbonačinu.
- Ko pritisnete gumb Edge (Robovi) na daljinskem upravljalniku, se na zaslonu začne izmenično prikazovati On Edge (0n 88 88 ; Način sesanja robov vklopljen) in Off Edge (0F F 88 88 ; Način sesanja robov izklopljen). Ko je prikazano On Edge (Način sesanja robov vklopljen), lahko tla čistite v načinu sesanja robov.
- Če istočasno izberete turbonačin in način sesanja robov, se na zaslonu začne izmenično prikazovati (88 8888—88 8888).



POZOR

Uporaba sesalnika

UPORABA ROBOTSKEGA SESALNIKA

SESANJE OBMOČJA

Ta način omogoča sesanje določenega območja, kjer je polno drobtin, piškotov, praha itd.

- Robotski sesalnik prestavite v prostor, kjer želite izvesti sesanje območja.

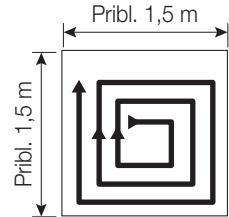

Gumb glavne enote	Gumb daljinskega upravljalnika	Vrstni red nastavitve
		1 Nastavite način.
		2 Preključite način.

- V načinu sesanja območja robotski sesalnik poseja 1,5 m dolgo in 1,5 m široko območje.
- Ko je sesanje končano, se na zaslonu prikaže End (Končano), Stop (Ustavitev) in Standby (V pripravljenosti).

OPOMBA Če se robotski sesalnik nahaja na polnilniku, način sesanja območja ni podprt.



- Ko pritisnete gumb Turbo na daljinskem upravljalniku, se na zaslonu začne izmenično prikazovati On turbo (00 00 00 00; Turbonačin vklopljen) in Off turbo (00 00 00 00; Turbonačin izklopljen). Ko je prikazano On turbo (Turbonačin vklopljen), lahko tla čistite v turbonačinu.
- Ko pritisnete gumb Edge (Robovi) na daljinskem upravljalniku, se na zaslonu začne izmenično prikazovati On Edge (00 Ed 99; Način sesanja robov vklopljen) in Off Edge (00 F1 Ed 99; Način sesanja robov izklopljen). Ko je prikazano On Edge (Način sesanja robov vklopljen), lahko tla čistite v načinu sesanja robov.
- Če istočasno izberete turbonačin in način sesanja robov, se na zaslonu začne izmenično prikazovati (00 00 00 → Ed 99).

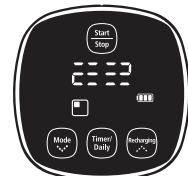

Navadni način

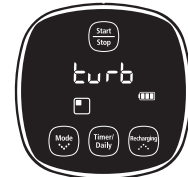

Turbonačin



Način sesanja robov



Čiščenje končano

Uporaba sesalnika

UPORABA ROBOTSKEGA SESALNIKA

MAKSIMALNO SESANJE

Robotski sesalnik se samodejno premika in sesa, dokler se ne izprazni baterija in utripa lučka najnižjega stanja napoljenosti.

- Če se sesanje začne, ko je robotski sesalnik priključen na polnilnik, se sesalnik hitreje vrne k polnilniku, saj si med sesanjem zapomni svoje prvotno mesto.
- Če je stanje baterije med sesanjem prenizko, se robotski sesalnik samodejno vrne k polnilniku in nadaljuje sesanje po polnjenju. (Nadaljevanje sesanja: enkrat)

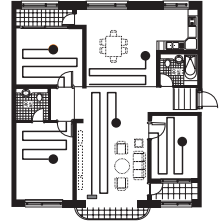

Gumb glavne enote	Gumb daljinskega upravljalnika	Vrstni red nastavitve
		1 Nastavite način.
		2 Preključite način.

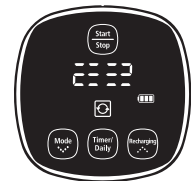

Navadni način



Turbonačin



Način sesanja robov



Funkcija nadaljevanja sesanja

OPOMBA

- Če robotski sesalnik oceni, da je sesanje končano, se funkcija nadaljevanja sesanja ne izvede.
- Če robotski sesalnik med polnjenjem prestavite ali pritisnete gumb, sesalnik oceni konec sesanja in ne nadaljuje sesanja.



POZOR

- Robotskega sesalnika med sesanjem ne prestavljajte ali pritiskajte gumbov. V tem primeru sesalnik oceni, da je sesanje zaključeno in začne čistiti od začetka.
- Ko pritisnete gumb Turbo na daljinskem upravljalniku, se na zaslonu začne izmenično prikazovati On turbo (08 88 88 88 ; Turbonačin vklopljen) in Off turbo (08 88 88 88 88 ; Turbonačin izklopljen). Ko je prikazano On turbo (Turbonačin vklopljen), lahko tla čistite v turbonačinu.
- Ko pritisnete gumb Edge (Robovi) na daljinskem upravljalniku, se na zaslonu začne izmenično prikazovati On Edge (08 88 88 88 ; Način sesanja robov vklopljen) in Off Edge (08 88 88 88 88 ; Način sesanja robov izklopljen). Ko je prikazano On Edge (Način sesanja robov vklopljen), lahko tla čistite v načinu sesanja robov.
- Če istočasno izberete turbonačin in način sesanja robov, se na zaslonu začne izmenično prikazovati (08 88 88 88 → 08 88 88 88).

Uporaba sesalnika

UPORABA ROBOTSKEGA SESALNIKA

ROČNO SESANJE

Robotski sesalnik lahko z daljinskim upravljalnikom premaknete v prostor, ki ga želite posesati.

- Robotski sesalnik prestavite v prostor, kjer želite izvesti ročno sesanje.
- Ročno sesanje je mogoče samo z daljinskim upravljalnikom.

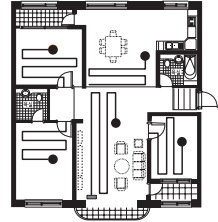

Gumb glavne enote	Gumb daljinskega upravljalnika	Vrstni red nastavitve
		1 Nastavite način.
		2 Preključite način.



- Če se robotski sesalnik nahaja na polnilniku, način ročnega sesanja ni podprt.



- Ko pritisnete gumb Turbo na daljinskem upravljalniku, se na zaslonu začne izmenično prikazovati On turbo (ON E0 E0 E0 E0) ; Turbonačin vklopljen) in Off turbo (E0 E0 E0 E0); Turbonačin izklopljen). Ko je prikazano On turbo (Turbonačin vklopljen), lahko tla čistite v turbonačinu.
- Ko pritisnete gumb Edge (Robovi) na daljinskem upravljalniku, se na zaslonu začne izmenično prikazovati On Edge (ON E0 E0 E0 E0) ; Način sesanja robov vklopljen) in Off Edge (E0 E0 E0 E0) ; Način sesanja robov izklopljen). Ko je prikazano On Edge (Način sesanja robov vklopljen), lahko tla čistite v načinu sesanja robov.
- Če istočasno izberete turbonačin in način sesanja robov, se na zaslonu začne izmenično prikazovati (E0 E0 E0 E0 → E0 E0 E0 E0).

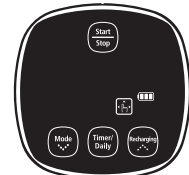

Navadni način

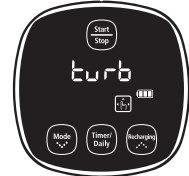

Turbonačin



Način sesanja robov

Smerni gumbi (naprej, levo, desno). Funkcija za nazaj ni podprta.

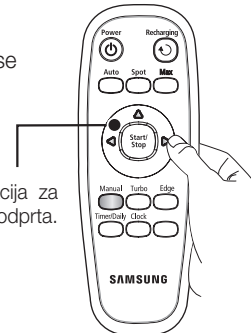

Uporaba sesalnika

UPORABA ROBOTSKEGA SESALNIKA

SESANJE PO URNIKU

Robotski sesalnik lahko nastavite tako, da sesa z začetkom ob določeni uri.

- Sesanje po urniku se izvaja samo, ko je sesalnik priključen na polnilnik.

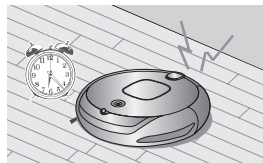

Gumb glavne enote	Gumb daljinskega upravljalnika	Vrstni red nastavitve	(Primer) Trenutni čas: 07:00. Želeni čas začetka sesanja: 09:30.
		1 Nastavite način sesanja po urniku in potrdite, da je nastavljeni čas pravilen.	AM 07:00
		2 Odprite nastavitve.	AM 07: Utripa
		3 Nastavite "uro".	AM 09: Utripa
		4 Potrdite "uro".	AM 09:00 Utripa
		5 Nastavite "minute".	AM 09:30 Utripa
		6 Dokončajte nastavitve.	AM 09:30 Utripa
		Prekličite nastavitve.	 Ikona je izklopljena.

Ko končate nastavev in pritisnete gumb (Start/Stop), namesto da bi pritisnili gumb Delay/Daily (Zakasnitev/dnevno), izvedete izhod iz načina sesanja po urniku.

Uporaba sesalnika

UPORABA ROBOTSKEGA SESALNIKA

NASTAVITEV DNEVNEGA SESANJA

Robotski sesalnik lahko nastavite tako, da sesa vsak dan z začetkom ob določeni uri.

- Dnevno sesanje se izvaja samo, ko je sesalnik priključen na polnilnik.

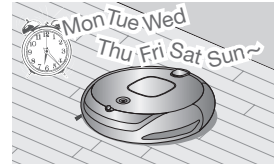

Gumb glavne enote	Gumb daljinskega upravljalnika	Vrstni red nastavitve	(Primer) Trenutni čas: 07:00. Zeleni čas začetka sesanja: 09:30.
		1 Nastavite način dnevnega sesanja in potrdite, da je nastavljeni čas pravilen. (Preverite čas načrtovanega sesanja.)	AM 07:00
		2 Odprite nastavev.	AM 07: Utripa Daily
		3 Nastavite "uro".	AM 09: Utripa Daily
		4 Potrdite "uro".	AM 09:00 Utripa Daily
		5 Nastavite "minute".	AM 09:30 Utripa Daily
		6 Dokončajte nastavitve.	AM 09:30 Daily
		Prekličite nastavitve.	Daily Ikona je izklopljena.

OPOMBA Ko končate nastavev in pritisnete gumb (Start/Stop), namesto da bi pritisnili gumb Delay/Daily (Zakasnitev/dnevno), izvedete izhod iz načina dnevnega sesanja.

Vzdrževanje nastavkov in filtra

UPORABA DODATNIH FUNKCIJ

Robotski sesalnik je opremljen z različnimi dodatnimi funkcijami za lažjo in priročnejšo uporabo.

- Dodatne funkcije lahko nastavite z daljinskim upravljalnikom.

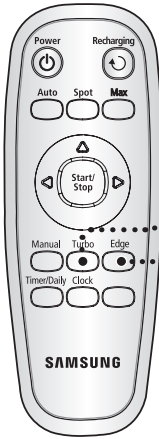

Turbonačin

Ko pritisnete gumb Turbo na daljinskem upravljalniku, se na zaslonu začne izmenično prikazovati On turbo (ON TURBO); Turbonačin vklopljen) in Off turbo (OFF TURBO); Turbonačin izklopljen).

On turbo (Turbonačin vklopljen): zmogljiva krtača se vrti z največjo hitrostjo.

Off turbo (Turbonačin izklopljen – navadni način): zmogljiva krtača se vrti z običajno hitrostjo.

Način sesanja robov

Ko pritisnete gumb Edge (Robovi) na daljinskem upravljalniku, se na zaslonu začne izmenično prikazovati On Edge (ON EDGE); Način sesanja robov vklopljen) in Off Edge (OFF EDGE); Način sesanja robov izklopljen).

On Edge (Način sesanja robov vklopljen): robotski sesalnik se med čiščenjem tal dotika ovir.

Off Edge (Način sesanja robov izklopljen – način izogibanja): robotski sesalnik se med čiščenjem tal izogiba oviram.



Ko je prikazano Off Edge (Način sesanja robov izklopljen – način izogibanja), se robotski sesalnik lahko zadane v tanke ali temne ovire.

ČIŠČENJE ROBOTSKEGA SESALNIKA

UPOŠTEVAJTE NAČINE ČIŠČENJA IN VZDRŽEVANJA

- Če je napajalni kabel poškodovan, stopite v stik s servisnim zastopnikom, da ne pride do nezgod.
- Ne uporabljajte sredstev ali mehanskih naprav, ki niso od proizvajalca in bi lahko poškodovale robotski sesalnik.

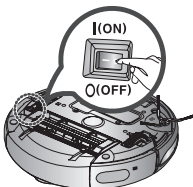

- Pred čiščenjem robotskega sesalnika vedno izklopite stikalo za napajanje na spodnji strani glavne enote. Robotski sesalnik se lahko nenadoma vklopi in povzroči poškodbe.



Vzdrževanje nastavkov in filtra

ČIŠČENJE OKENCA SENZORJA IN KAMERE

Pred čiščenjem robotskega sesalnika izklopite stikalo za napajanje na spodnji strani glavne enote.

- Nikoli ne pršite vode, razredčila, bencina itd. neposredno na glavno enoto robotskega sesalnika.

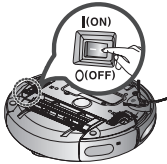

- Okence senzorja ali kamero nežno obrišite z mehko krpo.

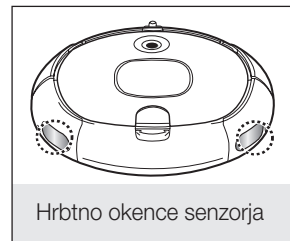
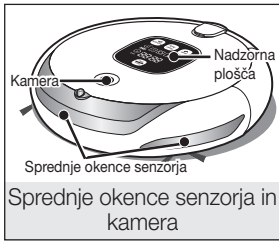

ČIŠČENJE ROBOTSKEGA SESALNIKA

HITRO ČIŠČENJE POSODE ZA PRAH

- Posodo za prah lahko enostavno izpraznite z običajnim sesalnikom, ne da bi jo odstranili.

1. Odprite pokrov posode za prah.

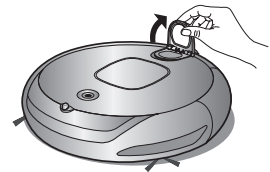

2. Če cev sesalnika vstavite v odprtino posode za prah, boste iz nje neposredno vsesali ves prah.

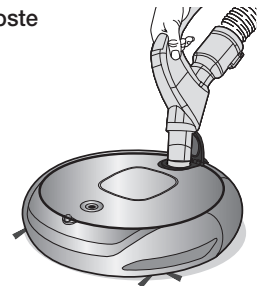

Vzdrževanje nastavkov in filtra

ČIŠČENJE POSODE ZA PRAH IN FILTRA

Pred čiščenjem posodo najprej izpraznite.

- Ko odstranjujete posodo za prah, pazite, da se ne strese prah.
- Posodo za prah izpraznite v naslednjih primerih.
 1. Ko se v posodi za prah nabere prah.
 2. Ko se moč sesanja nenadoma močno zmanjša.
 3. Ko se hrup nenadoma močno poveča.

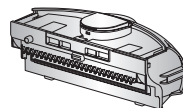

1. Pritisnite gumb PUSH (Potisni) za izvrženje posode za prah in posodo izvalcite.

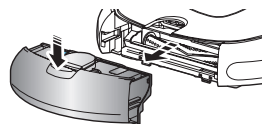

2. Odstranite pokrov posode za prah tako, da ga povlečete v smeri puščice na sliki.

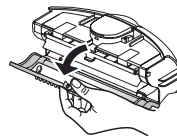

3. Iz posode za prah odstranite filter tako, da ga povlečete v smeri puščice na sliki.

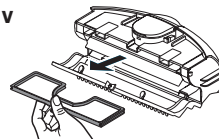

4. Obrišite prah s filtra in posode za prah.

* Lahko ju sperete.



5. Namestite filter v posodo za prah.

- Mrežast vzorec na filtru mora biti obrnjen navzdol. Ni ga mogoče namestiti narobe obrnjenega.

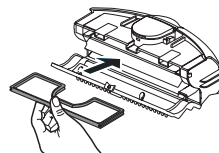

6. Zaprite pokrov posode za prah in posodo namestite v glavno enoto.

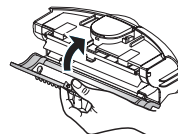

Vzdrževanje nastavkov in filtra

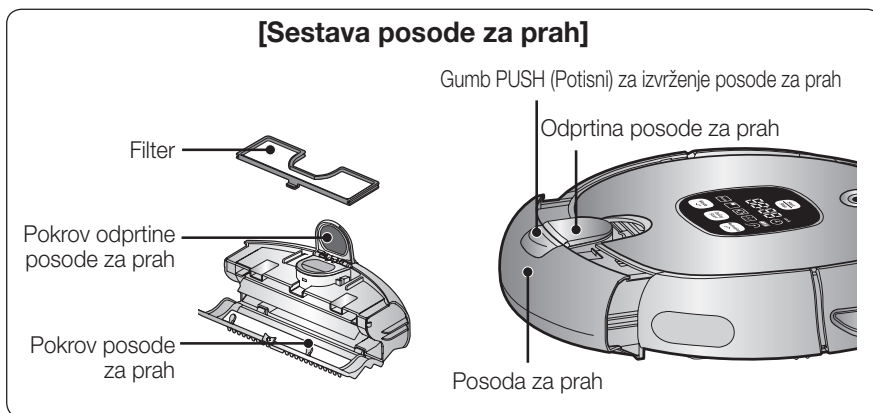

ČIŠČENJE ROBOTSKEGA SESALNIKA

ČIŠČENJE ZMOGLJIVE KRTAČE

Pred čiščenjem robotskega sesalnika izklopite stikalo za napajanje na spodnji strani glavne enote.



- Preden očistite zmogljivo krtačo, odstranite posodo za prah, saj lahko prah uhaja iz nje.

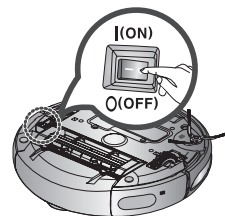

- 1. Odstranite posodo za prah tako, da pritisnete gumb PUSH (Potisni) za izvrženje posode.**

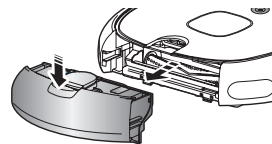

- 2. Preverite, ali je prisoten kakšen tujek, in nato pritisnite kljukico, s katero je pritrjen pokrov krtače, da ga odstranite.**

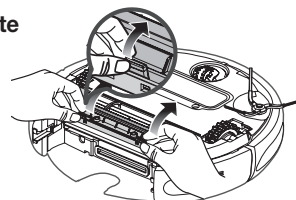

Vzdrževanje nastavkov in filtra

ČIŠČENJE ROBOTSKEGA SESALNIKA

3. Dvignite zmogljivo krtačo iz glavne enote.

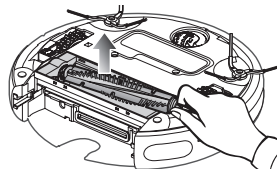

4. S čistilno krtačo ali sesalnikom odstranite morebitne tujke, kot so dolgi lasje ali vrvice, ki so se navile okoli zmogljive krtače.



5. Ko zmogljivo krtačo očistite, jo najprej pritrdite na strani stikala za napajanje, nato pa še na drugi strani.

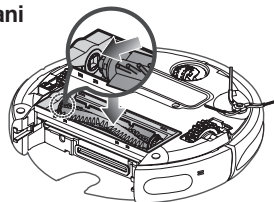

6. Ko ste vstavili 3 zatiče na vrh pokrova, potisnite drugi konec, da se zaskoči na mestu.

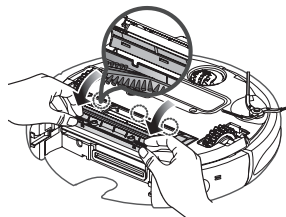

- Da preprečite zamašitev robotskega sesalnika, ne sesajte zobotrebcev in bombažnih blazinic.
- Če morebitnih tujkov ne morete odstraniti, stopite v stik s centrom za pomoč strankam.
- Ker zmogljiva krtača sesa prah s tal, se lahko okoli nje ovijejo lasje. Zmogljivo krtačo redno pregledujte in čistite.

Vzdrževanje nastavkov in filtra

ČIŠČENJE ROBOVSKEGA SESALNIKA

ČIŠČENJE STRANSKE VRTLJIVE KRTAČE ZA SESANJE ROBOV

Pred čiščenjem robotskega sesalnika izklopite stikalo za napajanje na spodnji strani glavne enote.

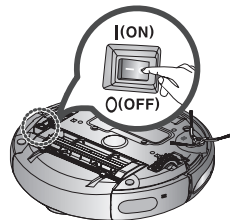

1. Preverite, ali je stranska vrtljiva krtača zvita in ali so se nanjo ujeli morebitni tujki.

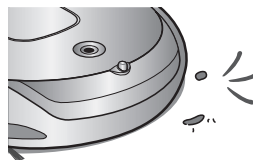

2. Z gumijastimi rokavicami primite krpo, ki ste jo namočili v vročo vodo, in z njo ovijte stransko vrtljivo krtačo. Pustite delovati 10 sekund in nato krtačo obrišite.

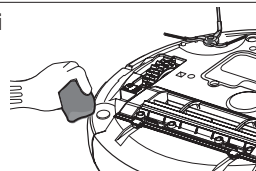

3. Obrnite stransko vrtljivo krtačo in ponovite postopek v koraku 2.

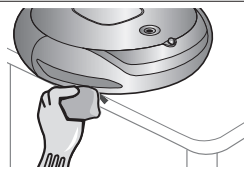

4. Če so se okoli glavne enote in stranske vrtljive krtače ovili lasje ali vrvice, krtačo odvijte s križnim izvijačem in jo odstranite. Pri nameščanju krtače preverite, da se oznaka "L" na stranski vrtljivi krtači za sesanje robov ujema z oznako "L" na glavni enoti. (Črka "R" je odtisnjena na desni stranski vrtljivi krtači.)

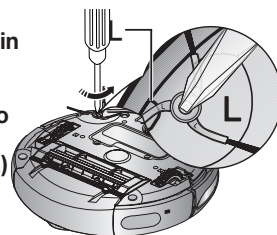

 Na stransko vrtljivo krtačo se pogosto ovijejo lasje in drugi tujki, zato jo redno čistite. Če se na stransko vrtljivo krtačo nabere preveč tujkov, se ta lahko poškoduje.

OPOMBA

Vzdrževanje nastavkov in filtra

ČIŠČENJE ROBOTSKEGA SESALNIKA

ČIŠČENJE POGONSKEGA KOLESKA

Pred čiščenjem robotskega sesalnika izklopite stikalo za napajanje na spodnji strani glavne enote.

- Če robotski sesalnik nenadoma začne "begati", so na pogonskem kolescu morda zagozdeni tujki.

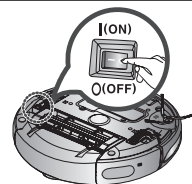

- 1. Ko želite očistiti pogonsko kolesce, na tla položite mehko krpo in previdno obrnite glavno enoto na glavo.**

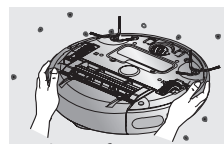

- 2. Preverite, ali so se na kolescu nabrali tujki in jih po potrebi odstranite s palčko ali topo pinceto.**

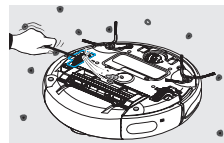

NEGA KRPE ZA TLA (MOŽNOST)

Umazana krpa za tla ima lahko neprijeten vonj, zato jo ustrezno čistite.

- 1. S spodnje strani robotskega sesalnika odstranite nastavek za krpo za tla.**

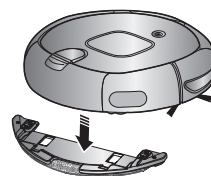

- 2. Odstranite krpo z nastavka.**

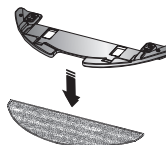

- 3. Krpo za tla očistite s čisto vodo.**



- 4. Pred naslednjo uporabo krpo za tla popolnoma posušite v dobro prezračevanem prostoru.**

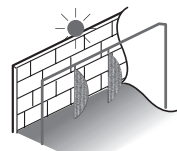

Odpravljanje težav

KAJ JE TREBA PREVERITI PRED KLICEM SERVISERJA

ZNAK	PREVERITE	REŠITEV
Robotski sesalnik ne deluje.	<ul style="list-style-type: none"> • Ali je posoda za prah sestavljena? • Ali je stikalo za napajanje vklopljeno? • Ali je na nadzorni plošči vklopljen način sesanja (Auto)? • Ali utripa raven nizkega stanja baterije in se na nadzorni plošči prikaže oznaka "LO"? • Robotski sesalnik ne deluje, če je baterija v daljinskem upravljalniku prazna. 	<ul style="list-style-type: none"> • Namestite posodo za prah. • Vključite stikalo za napajanje. • Pritisnite gumb (Auto). (Za izklop pritisnite in držite gumb (Auto) 3 sekunde ali dlje.) • Dvignite robotski sesalnik in ga ročno priključite na polnilnik, da ga napolnite. • Zamenjajte bateriji v daljinskem upravljalniku. (Vrsta AAA.)
Robotski sesalnik med sesanjem preneha delovati. 	<ul style="list-style-type: none"> • Ali utripa raven nizkega stanja baterije in se na nadzorni plošči prikaže oznaka "LO"? • Ali se je robotski sesalnik zataknil med žice na tleh? • Ali je robotski sesalnik obtičal, ker ne more prečkati višinske ovire? <ul style="list-style-type: none"> – Pogonsko kolesce je dvignjeno. • Ali je okoli pogonskega kolesca ovita drobna krpa (blago)? • Ali robotski sesalnik ne more prečkati praga? 	<ul style="list-style-type: none"> • Dvignite robotski sesalnik in ga ročno priključite na polnilnik, da ga napolnite. • Izklopite stikalo za napajanje in odstranite žice. • Izklopite stikalo za napajanje in prestavite robotski sesalnik v prostor, ki ga želite posesati. • Izklopite stikalo za napajanje in odstranite tujek. • Izklopite stikalo za napajanje in prestavite robotski sesalnik v prostor, ki ga želite posesati.
Moč sesanja je zmanjšana.	<ul style="list-style-type: none"> • Preverite, ali je posoda za prah polna. • Preverite, ali je sesalna odprtina zamašena z morebitnimi tujki. • Preverite, ali je filter zamašen. 	<ul style="list-style-type: none"> • Izklopite robotski sesalnik in izpraznite posodo za prah. • Izklopite stikalo za napajanje in odstranite tujke v sesalni odprtini. • Filter temeljito očistite.

Odpravljanje težav

KAJ JE TREBA PREVERITI PRED KLICEM SERVISERJA

ZNAK	PREVERITE	REŠITEV
Robotski sesalnik ne najde polnilnika.	<ul style="list-style-type: none">• Preverite, ali je napajalni vtič polnilnika ustrezno vključen v vtičnico.• Če se 1 m pred polnilnikom ali 0,5 m levo in desno od njega nahajajo ovire, jih odstranite.• Če se na vtiču za polnilec nahajajo morebitni tujki, jih obrišite s suho krpo.• Ali je NAVIDEZNI ČUVAJ nameščen blizu polnilnika?	<ul style="list-style-type: none">• NAVIDEZNEGA ČUVAJA prestavite na drugo mesto, da se robotski sesalnik lahko samodejno polni.
Robotski sesalnik gre mimo NAVIDEZNEGA ČUVAJA.	<ul style="list-style-type: none">• Ali sta bateriji v NAVIDEZNEM ČUVAJU izrabljeni?• Ali je NAVIDEZNI ČUVAJ nastavljen na način Guard (Čuvaj; navidezna vrata)?• Ali je lučka načina vklopljena?	<ul style="list-style-type: none">• Zamenjajte bateriji. (2 alkalni bateriji vrste D (LR20))• Nastavite NAVIDEZNEGA ČUVAJA na način Fence (Ograja; navidezna stena).• Preverite, ali je NAVIDEZNI ČUVAJ izklopljen in ga nato nastavite na zeleni način.
Čas delovanja baterij NAVIDEZNEGA ČUVAJA je prekratek.	<ul style="list-style-type: none">• Ali uporabljate manganovi suhi bateriji?	<ul style="list-style-type: none">• Zamenjajte bateriji z novima alkalnima baterijama. (2 alkalni bateriji vrste D (LR20))
Na nadzorni plošči se odštevajo številke, od 30, 29, 28 ... navzdol.	<ul style="list-style-type: none">• Ali ste robotski sesalnik med polnjenjem odklopili s polnilnika ali pritisnili gumb?	<ul style="list-style-type: none">• Ko robotski sesalnik vzamete s polnilnika ali pritisnete gub, se po 30-ih sekundah vrne k polnilniku na samodejno polnjenje.

Odpravljanje težav

ODPRAVLJANJE TEŽAV Z UPORABO KOD NAPAK



KODA NAPAKE	RAZLOG	REŠITEV
C 00	<ul style="list-style-type: none"> Robotski sesalnik se je med krmarjenjem ujel ali zagozdil. 	<ul style="list-style-type: none"> Izklopite stikalo za napajanje na spodnji strani in robotski sesalnik prestavite.
C 01	<ul style="list-style-type: none"> V zmogljivi krtači se je zagozdil tujek (vrvica, papir, igrača ali podobno). 	<ul style="list-style-type: none"> Izklopite stikalo za napajanje na spodnji strani in odstranite tujek iz zmogljive krtače.
C 02	<ul style="list-style-type: none"> Na levo pogonsko kolesce se je ujel tujek (vrvica, papir, igrača ali podobno). 	<ul style="list-style-type: none"> Izklopite stikalo za napajanje na spodnji strani in odstranite tujek z levega pogonskega kolesca.
C 03	<ul style="list-style-type: none"> Na desno pogonsko kolesce se je ujel tujek (vrvica, papir, igrača ali podobno). 	<ul style="list-style-type: none"> Izklopite stikalo za napajanje na spodnji strani in odstranite tujek z desnega pogonskega kolesca.
C 05	<ul style="list-style-type: none"> Preverite senzor odbijača. 	<ul style="list-style-type: none"> Zagozdeni odbijač malce povlecite ven.
C 06	<ul style="list-style-type: none"> Na okencu senzorja za ovire je tuja snov (prah, madež ali podobno). 	<ul style="list-style-type: none"> Izklopite stikalo za napajanje na spodnji strani in z mehko krpo obrišite tujo snov s sprednjega in hrbtnega okenca senzorja.
C 07	<ul style="list-style-type: none"> Na okencu senzorja za stopnice je tuja snov (prah, madež ali podobno). 	<ul style="list-style-type: none"> Izklopite stikalo za napajanje na spodnji strani in z mehko krpo obrišite tujo snov z okenca senzorja za stopnice.
C 08	<ul style="list-style-type: none"> Posoda za prah ni vstavljena. 	<ul style="list-style-type: none"> Vstavite posodo za prah tako, da zaslišite "klik".
C 09	<ul style="list-style-type: none"> Na stransko vrtljivo krtačo za sesanje robov se je ujel tujek (vrvica, blago ali podobno). 	<ul style="list-style-type: none"> Izklopite stikalo za napajanje na spodnji strani in obrišite tujek s stranske vrtljive krtače za sesanje robov.

* Če pritisnete gumb Start/Stop (Zagon/ustavitev) ali izklopite stikalo za napajanje, se koda napake izbriše.

Specifikacije izdelka

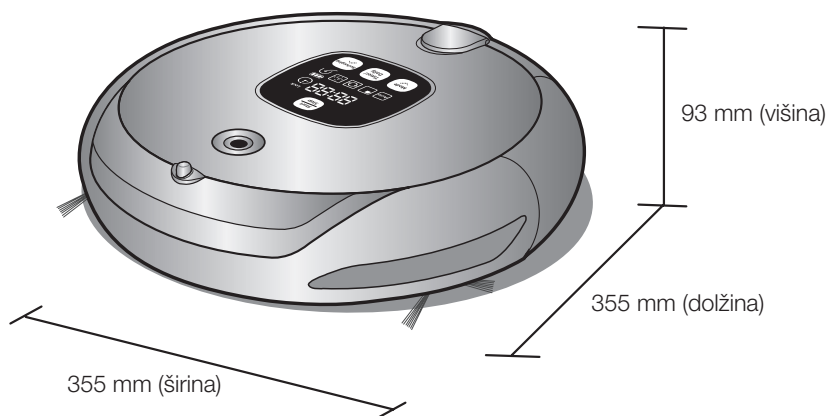

Osrednji del

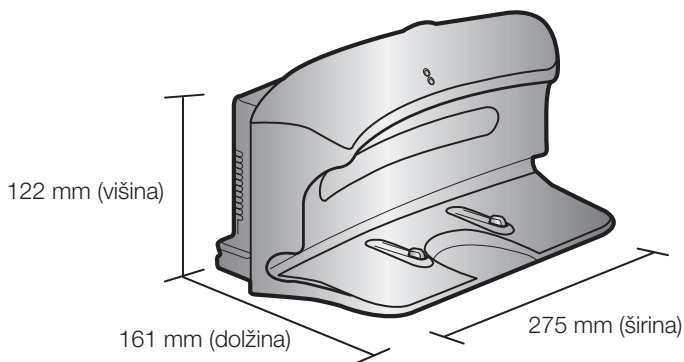

Polnilnik (postaja)

Specifikacije izdelka

KLASIFIKACIJA	ELEMENT	PODROBNOSTI
Mehanske specifikacije	Premer	355 mm
	Višina	93 mm
	Teža	4,0 kg
Električne specifikacije	Napetost	AC 220–240 V, 50–60 Hz
	Poraba energije polnilnika	50 W
	Poraba energije glavne enote	40 W
	Specifikacije baterije	14,4 V/2000 mA
Specifikacije čiščenja	Zmogljivost posode za prah	Približno 0,6 l
	Način polnjenja	Samodejno polnjenje/ročno polnjenje
	Način sesanja	Samodejno sesanje, sesanje območja, maksimalno sesanje, ročno sesanje, sesanje po urniku, nastavitev dnevnega sesanja
	Čas polnjenja	Približno 120 minut
	Čas sesanja (na podlagi sesanja trdih tal)	Približno 90 minut
Način sesanja		Prepoznavanje oblike stropa
Vrsta gumba glavne enote		Gumb na dotik

Sesalnik je skladen z naslednjima direktivama.

Direktiva o elektromagnetni združljivosti: 2004/108/EGS

Direktiva o nizki napetosti: 2006/95/ES

Memo

Memo

Memo

Memo

