



Radio / Cassette

St. Louis C33

7 642 183 110

(FM/MW/LW/DMS)

Installation instructions

Notice de montage



<http://www.blaupunkt.com>

 **BLAUPUNKT**

Safety precautions

Installation and connection regulations

- In the event that this equipment is installed or repaired incorrectly, this could cause malfunctions in the vehicle electronics.
- To avoid causing damage to your radio, use the corresponding Blaupunkt adapter cable to connect the 8-pin +/- ISO plug in the vehicle.

While installing and connecting this equipment, please observe the following safety notes:

- Disconnect the negative battery terminal.
- Observe the car manufacturer's safety instructions.
- If you drill any holes, make sure that you do not damage any parts of the vehicle.
- The diameter of the positive/negative cable must not be less than 1.5 mm².

Indications de sécurité

Consignes de montage et de branchement

- En cas d'erreur d'installation ou d'entretien, des perturbations peuvent survenir au niveau des systèmes électroniques du véhicule.
- Pour ne pas détériorer votre autoradio, branchez le connecteur ISO +/- 8 pôles du véhicule uniquement via un câble adaptateur Blaupunkt correspondant.

Pendant le montage et le branchement, observez les consignes de sécurité suivantes :

- Débrancher le pôle (-) de la batterie.
- Observer ce faisant les indications de sécurité du constructeur automobile.
- Veiller à ne pas endommager les pièces du véhicule en perçant des trous.
- La section transversale du câble (+) et (-) ne doit pas être inférieure à 1,5 mm².

Supplied Mounting Hardware Matériel de montage fourni

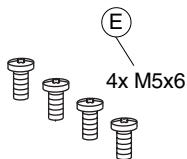
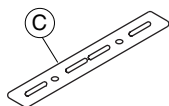
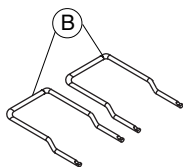
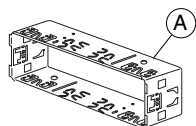

1.

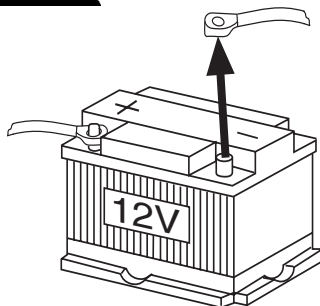

2.

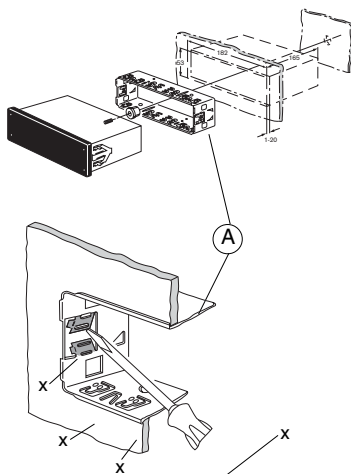

Bend as many taps as possible.
Plier si possible toutes les attaches.

INSTALLATION INSTRUCTIONS • NOTICE DE MONTAGE

3.

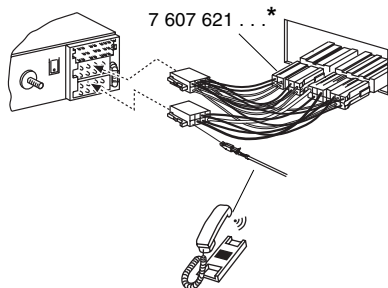

* Car-specific adapter cable which is available at your dealer.

Câble adaptateur spécifique au véhicule, disponible dans le commerce.

4.

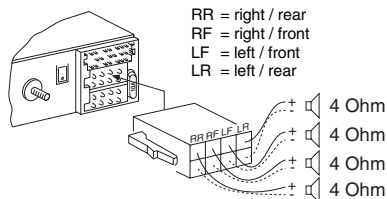

5.

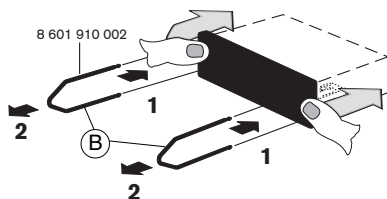

6.

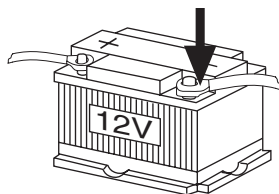

INSTALLATION INSTRUCTIONS • NOTICE DE MONTAGE

7.

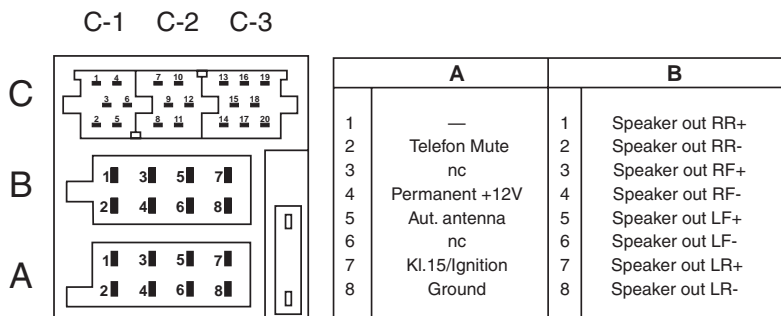

C					
C1		C2		C3	
1	nc	7	nc	13	Changer Bus
2	nc	8	nc	14	nc
3	nc	9	nc	15	+12V
4	nc	10	nc	16	-12V
5	nc	11	nc	17	Changer GND
6	nc	12	nc	18	AF - GND
				19	Line In - L 1,2V/10K
				20	Line In - R 1,2V/10K



ENGLISH

FRANÇAIS

INSTALLATION INSTRUCTIONS • NOTICE DE MONTAGE

8.

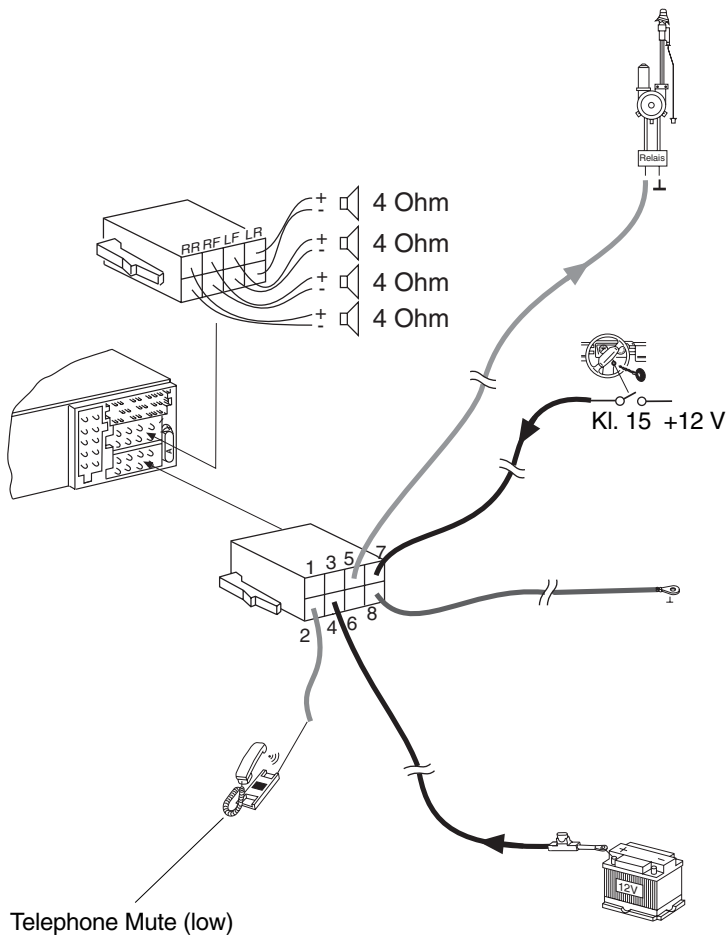

This information is subject to change without notice!
Sous réserve de modifications!

Service numbers / Numéros du service après-vente

Country:	Phone:	Fax:	WWW:
Germany	(D) 0180-5000225	05121-49 4002	http://www.blaupunkt.com
Austria	(A) 01-610 390	01-610 393 91	
Belgium	(B) 02-525 5454	02-525 5263	
Denmark	(DK) 44 898 360	44-898 644	
Finland	(FIN) 09-435 991	09-435 99236	
France	(F) 01-4010 7007	01-4010 7320	
Great Britain	(GB) 01-89583 8880	01-89583 8394	
Greece	(GR) 210 94 27 337	210 94 12 711	
Ireland	(IRL) 01-4149400	01-4598830	
Italy	(I) 02-369 62331	02-369 62464	
Luxembourg	(L) 40 4078	40 2085	
Netherlands	(NL) 023-565 6348	023-565 6331	
Norway	(N) 66-817 000	66-817 157	
Portugal	(P) 01-2185 00144	01-2185 11111	
Spain	(E) 902-120234	916-467952	
Sweden	(S) 08-7501500	08-7501810	
Switzerland	(CH) 01-8471644	01-8471650	
Czech. Rep.	(CZ) 02-6130 0441	02-6130 0514	
Hungary	(H) 01-333 9575	01-324 8756	
Poland	(PL) 0800-118922	022-8771260	
Turkey	(TR) 0212-3350677	0212-3460040	
USA	(USA) 800-2662528	708-6817188	
Brasil (Mercosur)	(BR) +55-19 3745 2769	+55-19 3745 2773	
Malaysia (Asia Pacific)	(MAL) +604-6382 474	+604-6413 640	

Blaupunkt GmbH





Radio / Cassette

St. Louis C33

7 642 183 110

(FM/MW/LW)

Installation instructions

Notice de montage



<http://www.blaupunkt.com>

 **BLAUPUNKT**

Safety precautions

Installation and connection regulations

- In the event that this equipment is installed or repaired incorrectly, this could cause malfunctions in the vehicle electronics.
- To avoid causing damage to your radio, use the corresponding Blaupunkt adapter cable to connect the 8-pin +/- ISO plug in the vehicle.

While installing and connecting this equipment, please observe the following safety notes:

- Disconnect the negative battery terminal.
- Observe the car manufacturer's safety instructions.
- If you drill any holes, make sure that you do not damage any parts of the vehicle.
- The diameter of the positive/negative cable must not be less than 1.5 mm².

Indications de sécurité

Consignes de montage et de branchement

- En cas d'erreur d'installation ou d'entretien, des perturbations peuvent survenir au niveau des systèmes électroniques du véhicule.
- Pour ne pas détériorer votre autoradio, branchez le connecteur ISO +/- 8 pôles du véhicule uniquement via un câble adaptateur Blaupunkt correspondant.

Pendant le montage et le branchement, observez les consignes de sécurité suivantes :

- Débrancher le pôle (-) de la batterie.
- Observer ce faisant les indications de sécurité du constructeur automobile.
- Veiller à ne pas endommager les pièces du véhicule en perçant des trous.
- La section transversale du câble (+) et (-) ne doit pas être inférieure à 1,5 mm².

Supplied Mounting Hardware Matériel de montage fourni

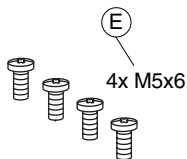
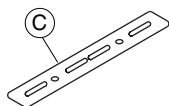
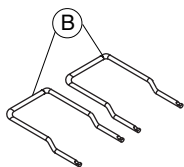
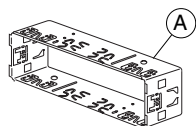

1.

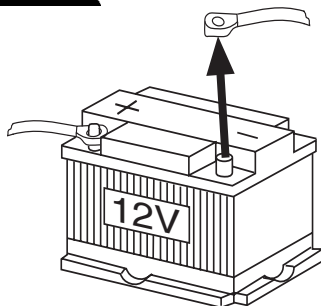

2.

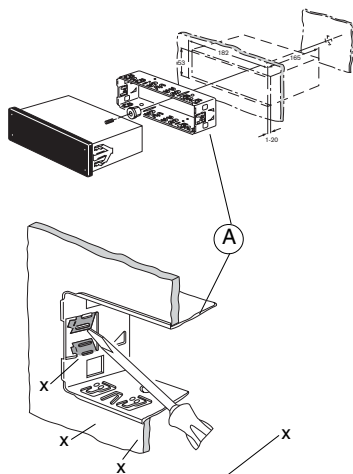

Bend as many taps as possible.
Plier si possible toutes les attaches.

INSTALLATION INSTRUCTIONS • NOTICE DE MONTAGE

3.

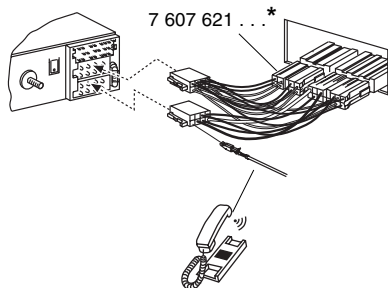

* Car-specific adapter cable which is available at your dealer.

Câble adaptateur spécifique au véhicule, disponible dans le commerce.

4.

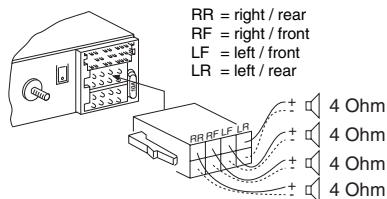

5.

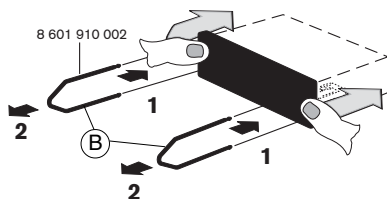

6.

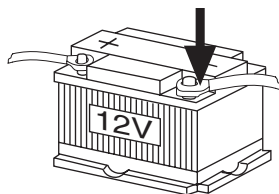

INSTALLATION INSTRUCTIONS • NOTICE DE MONTAGE

7.

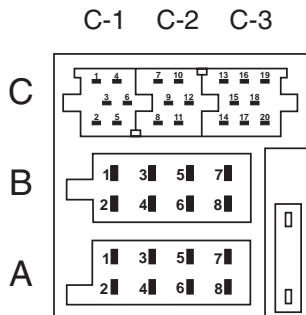

A		B	
1	—	1	Speaker out RR+
2	Telefon Mute	2	Speaker out RR-
3	nc	3	Speaker out RF+
4	Permanent +12V	4	Speaker out RF-
5	Aut. antenna	5	Speaker out LF+
6	nc	6	Speaker out LF-
7	Kl.15/Ignition	7	Speaker out LR+
8	Ground	8	Speaker out LR-

C					
C1		C2		C3	
1	nc	7	nc	13	nc
2	nc	8	nc	14	nc
3	nc	9	nc	15	nc
4	nc	10	nc	16	nc
5	nc	11	nc	17	nc
6	nc	12	nc	18	nc
				19	nc
				20	nc

ENGLISH

FRANÇAIS

INSTALLATION INSTRUCTIONS • NOTICE DE MONTAGE

8.

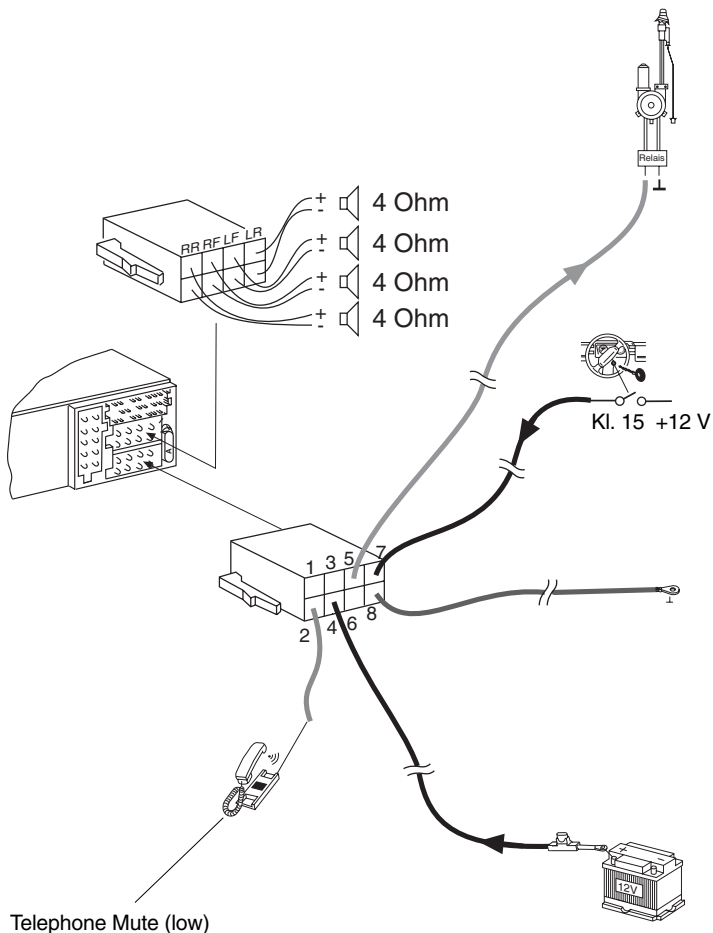

This information is subject to change without notice!
Sous réserve de modifications!