

Notice d'utilisation

Operating instructions

Manual de instruções

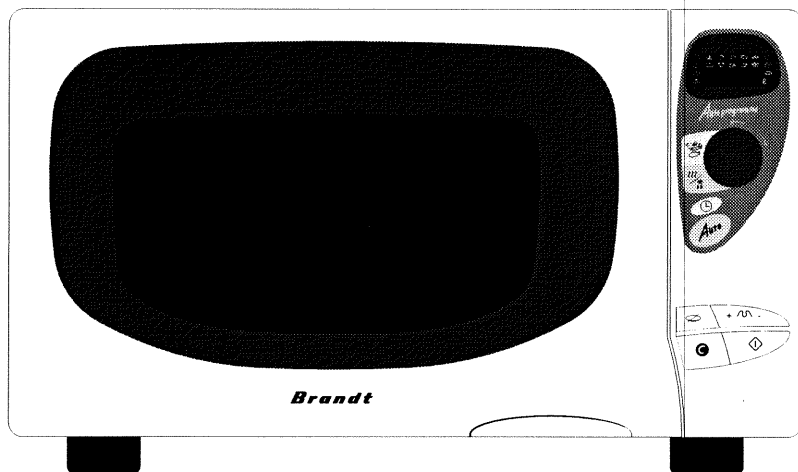

Four à Micro-ondes

Microwave oven

Forno micro-ondas

***Brandt***

## **FRANÇAIS**

Notice d'utilisation ..... page 3

## **ENGLISH**

Operating instructions..... page 20

## **PORTUGUÊS**

Manual de instruções ..... pág xx

# Sommaire

Installation	4
Principes de fonctionnement	5
Conseils importants	6
Présentation	8
Bandeau de Commande	9
Mise à l'heure / Equivalence des puissances micro-ondes	10
L'afficheur & le sélecteur	11
Programmation	12
La fonction gril / La fonction micro-ondes + gril	14
Programmation du gril	15
Sécurité enfant / Recommandations	16
Entretien / Nettoyage	17
Un petit problème ! Que faire ?	18
Service Après-Vente	19

Veillez lire attentivement ce guide d'utilisation.  
Vous y trouverez des conseils importants concernant la sécurité,  
l'installation et l'utilisation de votre appareil.

# Installation

## AVANT BRANCHEMENT

- Vérifiez que votre appareil n'a subi aucune avarie lors du transport (porte ou joint déformé, etc...). Si vous constatez un dommage quelconque, avant toute utilisation, contactez votre revendeur.
- Vérifiez la tension du secteur. Dans le cas d'une sous-tension PERMANENTE (200-210 volts), consultez votre installateur électricien.

## EMPLACEMENT

- Cet appareil est destiné à être posé (ou encastré selon les cas) sur un plan de travail situé à au moins 85 cm du sol.
- Posez l'appareil sur une surface plane et horizontale, éloigné de toute source de chaleur ou de vapeur. Pour assurer la bonne stabilité de l'appareil, le pied avant gauche est réglable (5 positions). Tournez-le pour rehausser ou descendre le four.
- Assurez-vous de la libre circulation de l'air **en dessous** et autour du four.

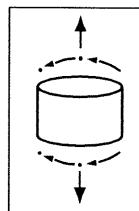

Pour les appareils posés sur un plan de travail, choisissez un emplacement qui laisse un espace libre minimum de :

- 5 cm entre les faces latérales de l'appareil et les murs
- 14 cm au-dessus de votre appareil
- 10 cm pour la face arrière.

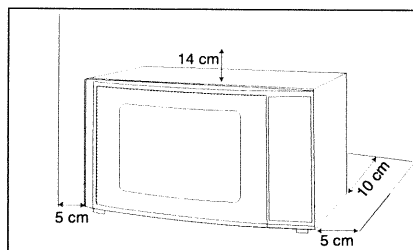

## RACCORDEMENT ELECTRIQUE

- Veillez à ne pas obstruer les orifices de ventilation situés en dessous et à l'arrière du four.
- Certains appareils sont encastrables : pour obtenir le kit d'encastrement correspondant, veuillez consulter votre revendeur.
- Veillez à ce que la fiche de prise de courant soit accessible après installation.
- Votre installation doit être équipée d'une protection thermique de 16 Ampères.
- Utilisez impérativement une prise de courant comportant **une borne de mise à la terre** et raccordée conformément aux normes de sécurité en vigueur.
- Prévoyez dans votre installation électrique un dispositif accessible par l'utilisateur qui doit être en mesure de séparer l'appareil du secteur et dont l'ouverture de contact est d'au moins 3 mm au niveau de tous les pôles.
- Ne faites pas fonctionner le four si le cordon d'alimentation ou sa fiche sont abîmés. **Dans ce cas, faites appel au distributeur ou à un technicien spécialisé formé par le fabricant.**

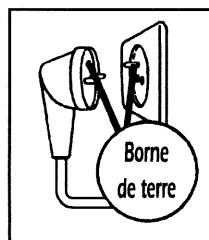
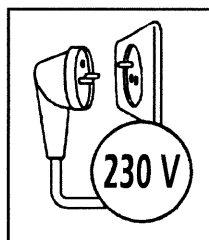

## Principes de fonctionnement

Les micro-ondes utilisées pour la cuisson sont des ondes électro-magnétiques. Elles existent couramment dans notre environnement comme les ondes radio-électriques, la lumière, ou bien les rayonnements infrarouges.

Leur fréquence se situe dans la bande des 2 450 MHz.

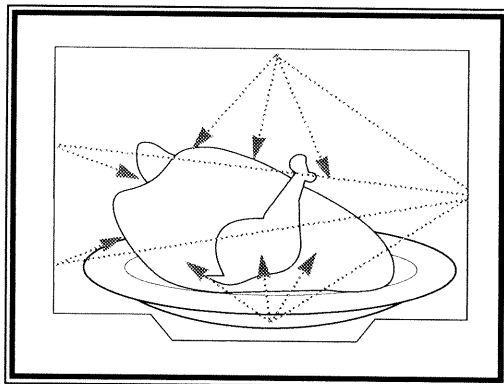

### Leur comportement :

- Elles sont réfléchies par les métaux.
- Elles traversent tous les autres matériaux.
- Elles sont absorbées par les molécules d'eau, de graisse et de sucre.

Lorsqu'un aliment est exposé aux micro-ondes il s'ensuit une agitation rapide des molécules, ce qui provoque un échauffement.

La profondeur de pénétration des ondes dans l'aliment est d'environ 2,5 cm, si l'aliment est plus épais, la cuisson à cœur se fera par conduction comme en cuisson traditionnelle. Il est bon de savoir que les micro-ondes provoquent à l'intérieur de l'aliment un simple phénomène de thermie et qu'elles ne sont pas nocives pour la santé.

## Conseils importants

- Votre appareil est exclusivement destiné à un usage domestique pour la cuisson, le réchauffage ou la décongélation des aliments. Le fabricant se dégage de toute responsabilité en cas d'utilisations non conformes.
- Avant toute utilisation, assurez-vous que les récipients et accessoires soient appropriés à l'usage de votre four à micro-ondes (par exemple : verre à feu, porcelaine...).
- Pour éviter de détériorer votre appareil, ne jamais le faire fonctionner à vide ou sans plateau.
- N'intervenez pas dans les orifices de la serrure en face avant; vous pourriez créer des dommages sur votre appareil qui nécessiteraient une intervention.
- Surveillez fréquemment le four lorsque les aliments sont chauffés ou cuits dans des récipients jetables en matière plastique, papier ou autre matériau combustible.
- Il est déconseillé d'utiliser des récipients métalliques, des fourchettes, des cuillères, des couteaux ainsi que des liens et agrafes en métal pour sachets de congélation. Cependant, occasionnellement, vous pouvez procéder à la remise à température d'aliments conditionnés en barquette d'aluminium de faible hauteur (maximum 4 cm) sans le couvercle. Toutefois, le temps de réchauffage sera légèrement plus long. Dans ce cas veillez à ce que la barquette soit bien positionnée au centre du plateau en verre et qu'en aucun cas elle ne soit à moins de 1 cm des parois métalliques ou de la porte de l'appareil.
- Pour les enfants, il est impératif :
  - de réchauffer les biberons sans la tétine, d'agiter le liquide et de tester sa température sur le dos de la main avant absorption par l'enfant.
  - de mélanger et de vérifier la température des aliments pour enfants avant consommation, afin d'éviter des brûlures internes graves.

## Conseils importants

- Il est recommandé de couvrir les aliments dans la plupart des cas; ils seront plus savoureux et votre appareil restera propre. Cependant, avant de cuire des aliments ou de réchauffer des liquides dans une bouteille ou un récipient hermétique, vous devez retirer le bouchon ou le couvercle.
- Le réchauffage ou la cuisson au micro-ondes des œufs dans leur coquille, en cocotte ou au plat, est à proscrire. Ceux-ci peuvent éclater et risquent de provoquer des brûlures graves ou la dégradation irrémédiable de votre four.
- Dans le cas de liquides en ébullition, afin d'éviter un débordement, attendez 20 secondes avant d'y introduire un élément quelconque et de le sortir de l'appareil.
- Dans le cas de petites quantités (une saucisse, un croissant, etc...) posez un verre d'eau à côté de l'aliment.
- Des temps trop longs peuvent dessécher l'aliment et le carboniser. Pour éviter de tels incidents, n'utilisez jamais les mêmes temps préconisés pour une cuisson au four traditionnel.
- Si l'on constate l'apparition de fumée, gardez la porte de l'appareil fermée, mettez hors tension ou déconnectez le four de l'alimentation électrique.
- **MISE EN GARDE** : Ne laissez les enfants utiliser l'appareil sans surveillance que si des instructions appropriées ont été données afin que l'enfant puisse utiliser le four de façon sûre et comprenne les dangers d'une utilisation incorrecte.

# Présentation

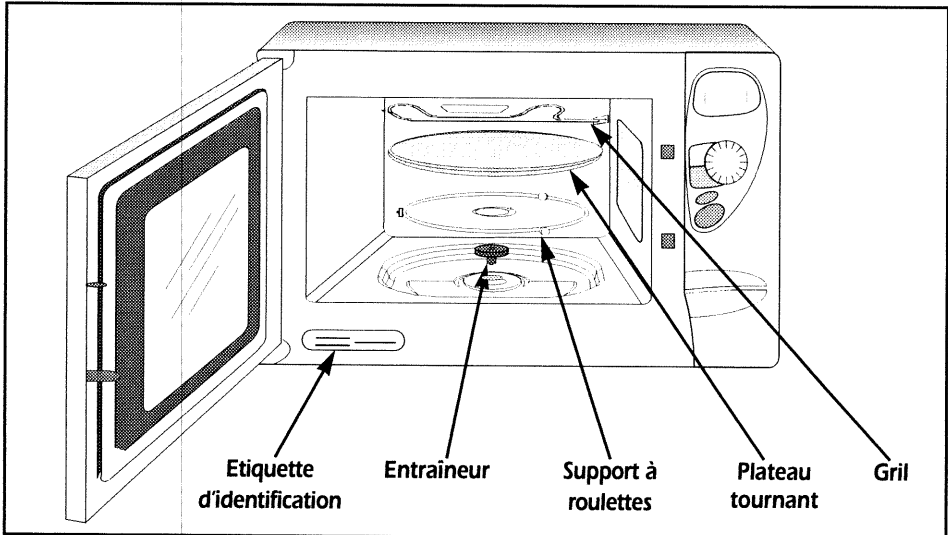

## ■ Le PLATEAU TOURNANT :

permet une cuisson homogène de l'aliment sans manipulation.

- Il est guidé dans sa rotation par l'entraîneur et le support à roulettes.
- Il tourne indifféremment dans les 2 sens.
- S'il ne tourne pas, vérifiez que tous les éléments soient bien positionnés.
- Il peut être utilisé comme plat de cuisson.
- Pour le retirer, prenez-le en utilisant les zones d'accès prévues à cet effet.

## ■ Le PLATEAU EN POSITION ARRÊT :







permet l'utilisation de grands plats sur toute la surface du four. Dans ce cas, il est nécessaire de tourner le récipient ou de mélanger son contenu à mi-programme.

## ■ Le SUPPORT A ROULETTES :

Ne cherchez pas à faire tourner manuellement le support à roulettes, vous risqueriez de détériorer le système d'entraînement. En cas de mauvaise rotation, assurez-vous de l'absence de corps étrangers sous le plateau.



## Bandeau de Commande

- A L'afficheur :**  
vous facilite la programmation en affichant :  
les catégories d'aliments et de fonctions, le  
temps ou le poids programmé, et l'heure.
- B Le sélecteur :**  
permet de choisir l'aliment, la fonction, le temps  
ou le poids.
- C La touche ALIMENTS  :**  
permet de choisir la catégorie d'aliment,  
à l'aide du sélecteur.
- D La touche FONCTIONS  :**  
permet de choisir la fonction appropriée,  
à l'aide du sélecteur.
- E La touche TEMPS  :**  
permet de programmer le temps à l'aide  
du sélecteur.
- F La touche "Auto" :**  
programme automatiquement le temps  
nécessaire selon le poids de l'aliment choisi.
- G La touche ARRÊT PLATEAU  :**  
permet l'arrêt du plateau tournant.
- H La touche GRIL  :** permet de sélection-  
ner l'un des 2 niveaux de puissances  
du gril.
- I La touche PAUSE/ANNULATION  :**  
permet d'interrompre ou d'effacer un pro-  
gramme en cours (un appui pour PAUSE,  
deux appuis pour ANNULATION).  
Elle permet également de mettre l'horloge  
à l'heure.
- J La touche DÉPART  :**  
permet de débiter votre programme.

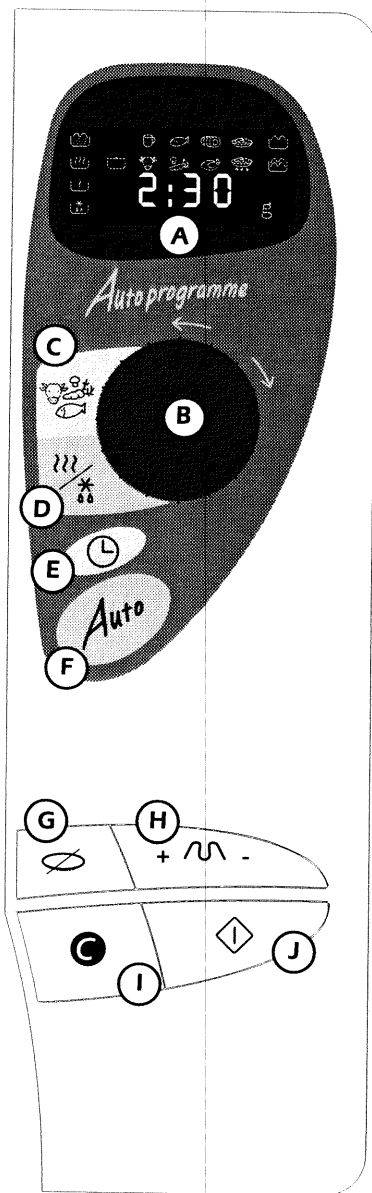

## Mise à l'heure

Après le branchement de votre appareil ou une coupure de courant, l'horloge indique 00:00, les deux points : clignotent.

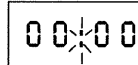

### Pour mettre l'horloge à l'heure :

- Appuyez pendant 5 secondes sur la touche **PAUSE / ANNULATION** .  
Les 4 chiffres clignotent, et un bip sonore vous invite à régler l'heure.

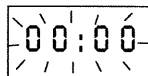



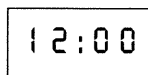

- Programmez l'horloge en tournant le sélecteur.

- Validez d'une simple pression sur la touche **PAUSE / ANNULATION** .  
**Votre horloge est à l'heure.**



## Equivalence des puissances micro-ondes

FONCTION	UTILISATION
 DÉCONGÉLATION	Pour décongeler tous les aliments. Pour terminer des cuissons délicates ou pour cuire très lentement.
 MIJOTAGE	Pour terminer les préparations commencées en CUISSON, telles que haricots, lentilles, laitages. (Cette fonction est disponible lorsqu'on commence la programmation en sélectionnant la fonction).
 RÉCHAUFFAGE	Pour réchauffer tous les aliments liquides ou solides, ainsi que les plats préparés frais ou surgelés.
 CUISSON FORTE	Pour cuire les légumes, poissons, volailles et potages.
<b>Puissance restituée : 900 W</b>	

**Lorsque vous sélectionnez un aliment, la puissance nécessaire est programmée automatiquement.**

# L'afficheur & le sélecteur

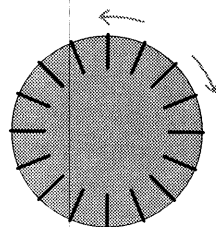
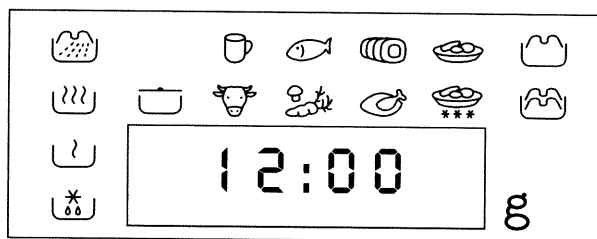

L'afficheur et le sélecteur vous guident pour choisir :

## les aliments

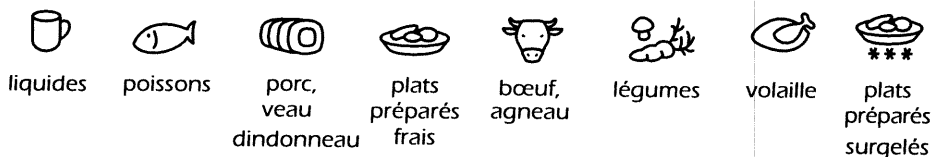

## les fonctions



## le gril 2 niveaux



**le poids** pour une programmation *Auto* g

**le temps de programmation** (ou l'horloge)

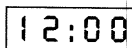

L'aliment ou la fonction en cours de sélection clignote.

# Programmation



**Votre appareil est maintenant branché et à l'heure.**

Ouvrez la porte à l'aide de la poignée. Placez l'aliment dans l'appareil, fermez la porte.

Si la porte n'est pas bien fermée, l'appareil ne fonctionnera pas.

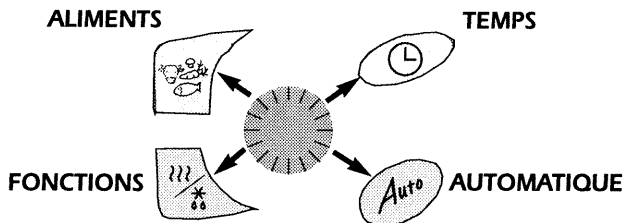
**Faites votre programmation avec les touches :**





- Lorsque l'appareil s'arrête, un triple signal sonore indique la fin du programme. Ce signal est répété toutes les minutes pendant dix minutes jusqu'à ouverture de la porte.
- Si vous estimez que le plat ne peut pas tourner, utilisez la touche **ARRÊT PLATEAU**  avant ou en cours de programme.
- En cas d'erreur de programmation, appuyez deux fois sur la touche **ANNULATION** .

.....

**Les programmations à votre disposition :**

## Programmation express

- ▼ programmez le temps désiré (ex. 2 minutes) à l'aide du sélecteur. Les fonctions  et  clignotent alternativement pour indiquer la puissance express 900 W.

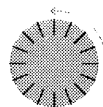



2:00

- ▼ Appuyez sur la touche **DÉPART** .

# Programmation

## Programmation par la fonction

- ▼ Appuyez sur la touche **FONCTIONS**, faites votre choix.  
Dans ce mode, la fonction **MUOTAGE**  est disponible.
- ▼ Appuyez sur la touche **TEMPS**,  
programmez le temps désiré à l'aide du sélecteur.
- ▼ Appuyez sur la touche **DÉPART** .

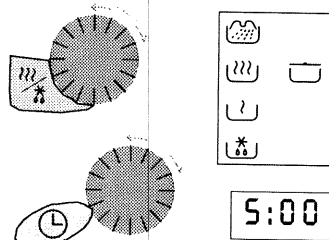

## Programmation par l'aliment

- ▼ Appuyez sur la touche **ALIMENTS**, faites votre choix.
- ▼ Appuyez sur la touche **FONCTIONS**, faites votre choix;  
la puissance micro-ondes sera adaptée à l'aliment choisi.
- ▼ Appuyez sur la touche **TEMPS**,  
programmez le temps désiré à l'aide du sélecteur.
- ▼ Appuyez sur la touche **DÉPART** .

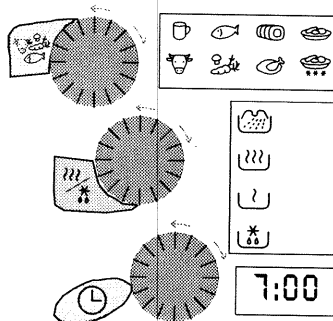

# Programmation Auto

## Programmation automatique

Avec la touche *Auto*, le temps est calculé *automatiquement* en fonction du poids de l'aliment.

- ▼ Appuyez sur la touche **ALIMENTS**, faites votre choix.
- ▼ Appuyez sur la touche **FONCTIONS**, faites votre choix.
- ▼ Appuyez sur la touche *Auto*; **50 g** clignote,  
vous demandant d'indiquer le poids à l'aide du sélecteur.
- ▼ Appuyez sur la touche **DÉPART** .  
**Le temps adéquat s'affiche automatiquement.**

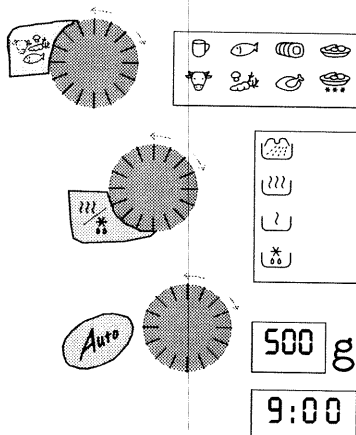

## La fonction gril



Cette fonction permet de dorer les aliments tels que gratins et viandes. Elle peut être utilisée avant ou après la cuisson, selon les recettes.



- Le gril est rabattable; afin de faciliter le nettoyage :

- horizontal pour les gratins, grillades à plat
- vertical pour l'entretien de la voûte

Laisser refroidir le gril 25 minutes après utilisation avant de le toucher.

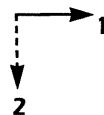
### Positions du gril



- Lors de l'utilisation du gril, il est nécessaire de se protéger les mains pour sortir les plats et d'utiliser des récipients qui supportent des températures élevées, tels que le verre à feu ou la céramique.
- Vous avez à votre disposition 2 niveaux de gril : **GRIL FORT**  (un appui sur la touche GRIL) et **GRIL DOUX**  (deux appuis).  
En règle générale, utilisez le niveau **GRIL FORT** pour griller viandes et poissons, et utilisez le niveau **GRIL DOUX** en fonction micro-ondes + gril pour gratiner, ainsi que pour dorer les aliments les plus délicats.

## La fonction micro-ondes + gril



Cette fonction donne la possibilité d'utiliser simultanément les micro-ondes et le gril, ce qui permet une cuisson rapide.

- Vous avez à votre disposition les 2 niveaux de gril ainsi que 3 fonctions micro-ondes.

### La CLAYETTE

en fonction GRIL, permet de dorer les aliments de faible hauteur.

Lors de son utilisation en fonction **micro-ondes + gril**,

elle doit obligatoirement être bien centrée sur le

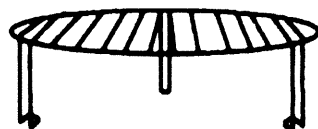

plateau tournant. L'utilisation de la clayette avec des récipients métalliques est exclusivement réservée à la fonction **gril seul**. Toutefois, vous pouvez réchauffer un aliment dans une barquette en aluminium en l'isolant de la clayette à l'aide d'une assiette.







La Clayette

## Programmation du gril

### Utilisation du gril 2 niveaux de puissance

- Appuyez une fois sur la touche **GRIL** pour sélectionner **GRIL FORT** , 2 fois pour sélectionner **GRIL DOUX** . Programmez le temps voulu et appuyez sur **DÉPART** . Un troisième appui sur la touche **GRIL** arrête le gril.

### Utilisation de la fonction micro-ondes + gril simultanée :

- Sélectionnez votre **ALIMENT**  parmi les catégories proposées. Sélectionnez ensuite la **FONCTION**  micro-ondes + gril . La puissance micro-ondes ainsi que le niveau de gril seront automatiquement adaptés à votre plat.
- Si votre aliment ne correspond à aucune catégorie proposée, sélectionnez la **FONCTION**  micro-ondes + gril . Dans ce cas, une puissance micro-ondes moyenne et le gril fort sont préprogrammés.







## Sécurité enfant

Après avoir programmé le four et fermé la porte, si vous attendez plus de **30 s** avant d'appuyer sur la touche **DÉPART**  le four ne démarrera pas et l'afficheur indiquera **SECU**. Cette sécurité empêche le fonctionnement de l'appareil à vide.

Pour démarrer l'appareil, ouvrez puis refermez la porte et appuyez sur la touche **DÉPART** .

## Recommandations

### EN COURS DE CUISSON :

- Si vous avez fait une programmation par le **TEMPS** ou avec la touche *Auto*:
  - > **vous pouvez modifier la durée à tout moment.**
- Vous pouvez arrêter ou démarrer le plateau tournant en cours de cuisson en appuyant sur la touche **ARRÊT PLATEAU** .
- Pour modifier le choix de la **FONCTION** ou de l'**ALIMENT**, il faut appuyer deux fois sur la touche **PAUSE/ANNULATION**  et recommencer la programmation.
- Si vous ouvrez la porte avant la fin du programme, refermez la porte et appuyez sur la touche **DÉPART**  pour remettre votre appareil en fonctionnement.
- En fonction décongélation , une sonnerie longue à mi-programme vous rappelle qu'il faut retourner l'aliment pour un meilleur résultat. Refermez la porte et appuyez sur la touche **DÉPART**  pour redémarrer le four.
- Si vous retirez l'aliment avant la fin de la programmation, annulez les données qui restent affichées en appuyant deux fois sur la touche **ANNULATION** .

### REMARQUES :

- Si, après avoir commencé une programmation, vous n'appuyez pas sur la touche **DÉPART**  au bout de trois minutes, le programme sera annulé (l'heure s'affichera de nouveau).



## Entretien / Nettoyage

- **L'entretien régulier de votre appareil vous permettra de le garder en bon état de marche.** Pour éviter les salissures trop importantes, il est nécessaire de couvrir les récipients dans la plupart des cas.

- **Veillez à ce que le plan de travail sur lequel repose votre four reste toujours propre;** l'aspiration de saletés autour de votre four pourrait endommager l'appareil.

- Le nettoyage des appareils possédant uniquement la fonction micro-ondes se fait au moyen d'une éponge humide et savonneuse, tant pour l'intérieur que pour l'extérieur.

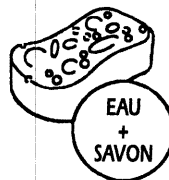

- En cas d'odeur ou de four encrassé, faites bouillir de l'eau additionnée de jus de citron ou de vinaigre dans une tasse pendant 2 min et nettoyez les parois avec un peu de liquide vaisselle.

- Pour les appareils munis d'une fonction gril ou chaleur pulsée, le dessus et les sorties d'air arrières sont très chauds. Veillez à ne pas toucher ces parties après utilisation. Procédez au nettoyage de l'intérieur du four lorsque celui-ci est tiède. Utilisez un tampon au savon en fine laine d'acier.

- Le plateau peut être retiré pour faciliter le nettoyage. Pour ce faire, prenez-le par les zones d'accès prévues à cet effet.

Si vous enlevez l'entraîneur, évitez de faire pénétrer de l'eau dans le trou de l'axe moteur.

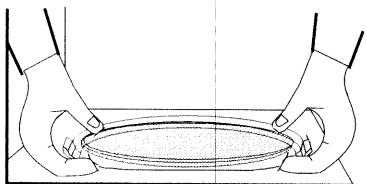

N'oubliez pas de remettre l'entraîneur, le support à roulettes et le plateau tournant.

- Les pourtours de la porte et de l'enceinte doivent toujours être propres. Si, par excès de salissures, ces surfaces se trouvent endommagées, faites appel à un technicien spécialisé avant d'utiliser votre appareil.

- L'emploi de produits abrasifs, d'alcool ou de diluant est déconseillé; ils sont susceptibles de détériorer l'appareil.

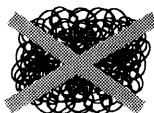



# Un petit problème ! Que faire ?

## Problèmes

- ▼ L'appareil affiche " S E C U "
- ▼ Le temps se décompte mais l'appareil ne fonctionne pas (le plateau ne tourne pas, l'éclairage ne s'allume pas et l'aliment n'est pas chauffé)
- ▼ Le four est bruyant
- ▼ Vous constatez de la buée sur la vitre
- ▼ La fumée se dégage du gril en début de programme
- ▼ Le plateau ne tourne pas correctement
- ▼ L'aliment n'est pas chauffé en programme micro-ondes
- ▼ L'appareil produit des étincelles

## Conseils

- ▲ Annuler la sécurité enfant : ouvrir puis refermer la porte et appuyer sur la touche DÉPART .
- ▲ Appuyer sur la touche ARRÊT PLATEAU  pendant 5 secondes.
- ▲ Ajuster le pied réglable.  
Nettoyer les roulettes et la zone de roulement sous le plateau tournant.
- ▲ Nettoyer la grille d'aspiration sous l'appareil.
- ▲ Enlever tous dépôts de résidus de cuisson sur l'élément chauffant.
- ▲ Nettoyer les roulettes et la zone de roulement sous le plateau tournant.
- ▲ Nettoyer la grille d'aspiration sous l'appareil.  
Vérifier que les ustensiles conviennent aux fours à micro-ondes.
- ▲ Vérifier que l'entraîneur et le support à roulettes soient bien positionnés.  
Bien nettoyer l'appareil : retirer graisses, particules de cuisson ...  
Eloigner tout élément métallique des parois du four.  
Ne jamais utiliser d'éléments métalliques avec la clayette.

## Service Après-Vente

▪ Si l'appareil a subi une avarie quelconque :

- **Vérifiez que la porte n'est pas déformée.**

▪ Si l'appareil ne fonctionne pas,  
**avant** d'appeler le réparateur :

- Vérifiez l'alimentation électrique.

- Vérifiez la bonne fermeture de la porte.

- Vérifiez votre programmation.

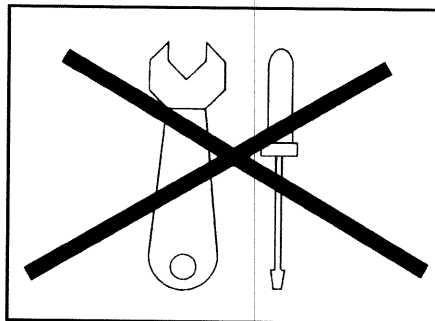

**ATTENTION : ne cherchez jamais  
à intervenir vous-même.**

MISE EN GARDE : il est dangereux pour quiconque autre qu'une personne formée, d'effectuer une opération de maintenance ou une réparation qui nécessite le retrait d'un couvercle protégeant contre l'exposition à l'énergie des micro-ondes.

**Les éventuelles interventions sur votre appareil doivent être effectuées par un professionnel qualifié dépositaire de la marque.**

## **ENGLISH**

Operating instructions..... page 21

## **PORTUGUÊS**

Manual de instruções ..... pág 38

## Table of contents

Installation . . . . .	23
How microwaves work . . . . .	24
Important instructions . . . . .	25
General description . . . . .	27
Control panel . . . . .	28
Setting the clock / Microwave power settings . . . . .	29
The display & the selector knob . . . . .	30
Programming . . . . .	31
The grill function / Microwave + grill function . . . . .	33
Programming the grill . . . . .	34
Child lock / Recommendations . . . . .	35
Care & cleaning . . . . .	36
Troubleshooting guide . . . . .	37
After-sales service . . . . .	38

Please read this user manual carefully. It contains important instructions concerning installation, use and security measures.

# Installation

## BEFORE CONNECTION

- Make sure that your oven has not suffered any damage during transport (deformed door or door seal, etc.). If you see any signs of damage, contact your dealer before use.
- Check the power voltage. If there is a PERMANENT undervoltage (200-210 volts), consult your electrical installer.

## LOCATION

- The oven is meant to be set on a work surface at least 85 cm above floor level.
- Place the oven on a flat and horizontal surface, away from any source of heat or steam. To ensure the stability of the microwave oven, the front left foot is adjustable (5 positions). Turn it to raise or lower the appliance.
- Make sure that air may circulate freely around the oven.

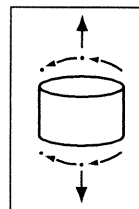

Leave sufficient space around the oven :

- 5 cm between the sides of the oven and any walls or objects
  - 14 cm above the oven
  - 10 cm behind the oven.
- Make sure that nothing obstructs the ventilation louvers at the back of the appliance.
  - Make sure the electrical plug will be accessible after installation.

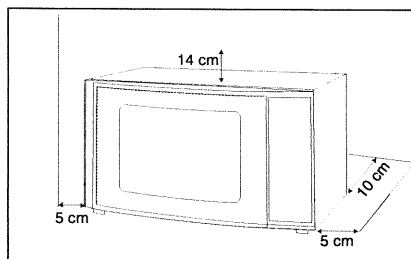

## ELECTRICAL CONNECTION

- Your installation must be protected by a 16 Amp thermal fuse.
- It is mandatory to use a power point with a **ground terminal**, connected in accordance with current safety regulations.
- In your electrical installation, provide a device that is accessible to the installer, capable of separating the appliance from the mains power and whose contact opening is at least 3 mm at all of the poles.
- Never operate the oven if the supply cord and/or its plug are damaged. **In case of damage, call in a specialised technician trained by the manufacturer.**

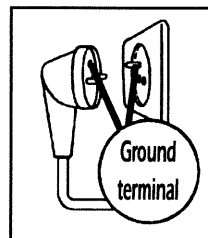
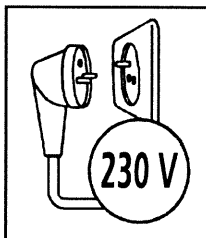

## How microwaves work

The microwaves used for cooking are electro-magnetic waves. They exist in our environment as do radioelectric waves, light, and infrared rays.

Their frequency is 2,450 MHz.

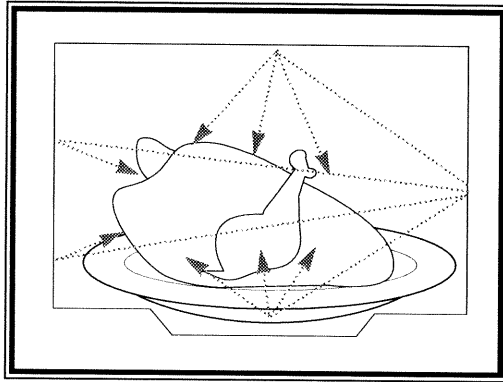

### Their characteristics :

- They are reflected by metals.
- They pass through all other materials.
- They are absorbed by water, sugar and fat molecules.

When food is exposed to microwaves there follows a vibration of the molecules at a speed of 2 billion 450 million times a second, which in turn produces heat.

The depth of penetration of the waves into food is about 2.5 cm. If the food is thicker the centre is cooked by normal conduction of heat. It is worth noting that the microwaves produce a simple heat reaction inside food and are not at all harmful to your health.

## Important instructions

- Your appliance is designed exclusively for the domestic purposes of defrosting, heating or cooking foods. The manufacturer bears no responsibility in the case of improper usage.
- To avoid deterioration of your microwave oven, never operate it empty or without the turntable.
- Never tamper with the lock mechanism of your microwave oven; this could cause damage requiring repair by an authorised technician.
- Before use, make sure that the containers are appropriate for microwave usage (e.g.: heat resistant glass, porcelain, etc.).
- It is not advisable to use metal recipients, forks, spoons, knives, metal ties or staples for deep-freeze bags.
- For baby food and children's food, it is essential :
  - to remove the nipple before heating up baby bottles, shake the contents and test the temperature on the back of your hand before feeding.
  - to stir and verify the temperature of children's foods before serving to avoid causing serious internal burns.
- **WARNING** : Do not allow children to use the microwave oven without supervision unless they have been thoroughly instructed in the proper use and the dangers of improper operation.



## Important instructions

- It is advisable to cover food in most cases. It will be tastier and your oven will stay cleaner. However, be sure to remove the cap or lid before cooking foods or heating liquids in a sealed bottle or container, which could otherwise explode.
- The heating or cooking of boiled, coddled eggs or fried eggs by microwave is prohibited. They can burst and cause serious burns or irreparable damage to your oven.
- When heating liquids, the boiling point may be reached without the typical bubbles appearing on the surface. To prevent liquids from boiling over and possible burns, wait 20 seconds before removing the containers from the appliance or adding anything to the liquids, to avoid sudden spurting of the liquid.
- For small amounts (one sausage, a single croissant, etc.), place a glass of water alongside the food item.
- Time settings that are too long may dry out and burn the food. To avoid such incidents, never use the same cooking times as those recommended for traditional ovens.
- Be sure to watch closely when heating or cooking foods in disposable plastic or paper containers or any other combustible material, due to fire hazard.
- If smoke appears, keep the oven door closed and disconnect the oven or turn it off.

## General description

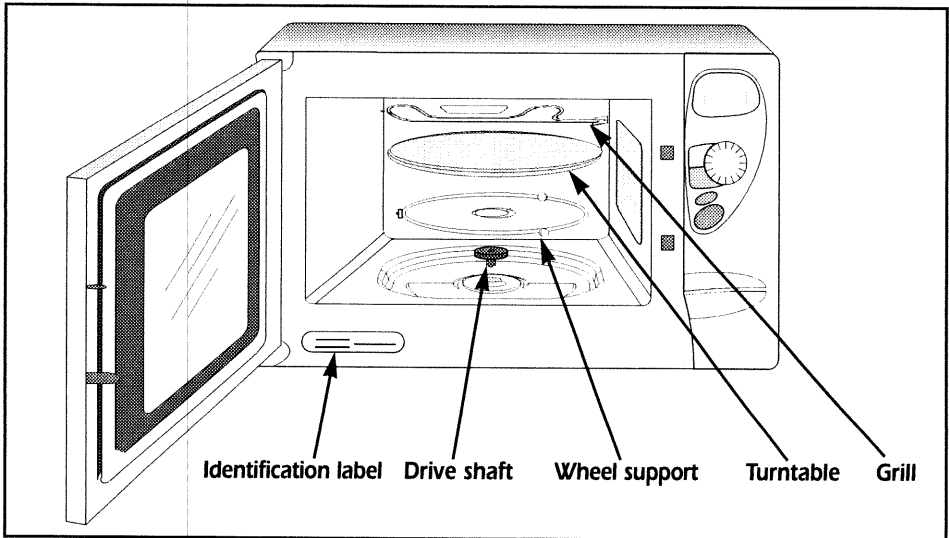

### ■ THE TURNTABLE :

ensures equal cooking of food throughout with no need to intervene.

- It may be used as a cooking dish.
- Rotation is controlled by the drive shaft and the wheel support.
- The turntable rotates in both directions.
- If it does not turn, verify that all components are properly positioned.
- For easy removal, wells are provided on either side.

### ■ TURNTABLE OFF :

stops the turntable from revolving in order to use platters which require the entire oven space. When off, remember to turn the recipient or stir the contents.

### ■ THE WHEEL SUPPORT :

Do not try to rotate the roller ring manually, as you could damage the drive system. If it does not turn smoothly, make sure that there is nothing in the well beneath the turntable.

## The control panel

### A Display window :

to simplify programming, the display indicates : the time of day, the types of food and functions, the minutes / seconds or weight programmed.

### B The selector knob :

to choose the food type, function, program time or weight.

### C FOOD TYPE key :

to choose the food type, with the selector knob.

### D FUNCTION key :

to choose the appropriate function, with the selector knob.

### E TIME key :

used to set the program time, with the selector knob.

### F "Auto" key:

automatically sets the correct program time according to a specified food type and weight.

### G STOP-TURNTABLE key :

to stop the turntable from revolving.

### H GRILL key :

to select low or high grill.

### I PAUSE/CANCEL key :

to interrupt (press once) or cancel a program (press twice). Also used to set the clock.

### J START key :

to start all programs.

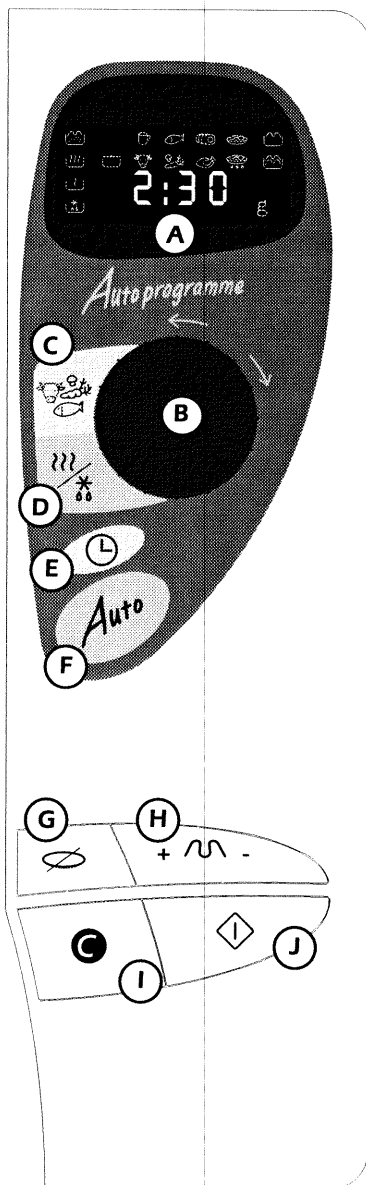

## Setting the clock

After first plugging in your microwave oven or after a power outage, the clock reads 00:00 and the two dots flash.

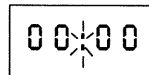

### To set the clock :

- Press the **PAUSE / CANCEL** key  for 5 seconds.

The 4 numbers flash, and a tone sounds indicating the hour must be set.

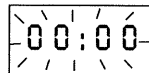



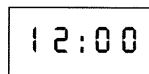

- Turn the selector knob to display the correct time.

- Validate by pressing the **PAUSE / CANCEL** key .

**Your clock is set.**



## Microwave power settings

POWER SETTING		APPLICATION
	DEFROST	To defrost all frozen food or to top off cooking of delicate dishes or cook very slowly.
	SIMMER	To finish programs begun with the HIGH COOK power setting, for instance beans, lentils, or dairy products. (This power setting is available when you program with the function key.)
	HEAT	To heat up all liquids and all fresh or frozen pre-cooked dishes.
	HIGH COOK	To cook vegetables, fish, poultry and soup.

**Microwave output power : 900 W**

**When you select the type of food, the appropriate power setting is automatically programmed.**

# The display & the selector knob

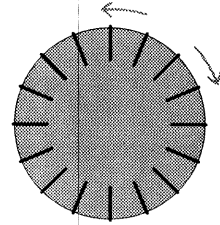
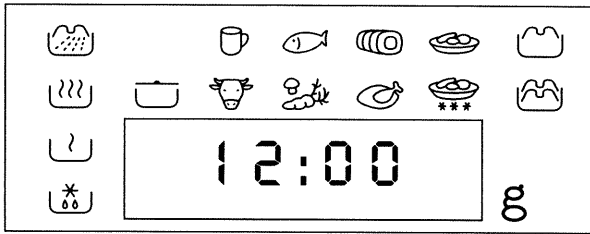

The display and the selector knob guide you in your choice of :

## food types



## functions



## the 2-position grill



the weight for *Automatic* programming g

the program time (or clock)

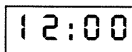

The food type or function being selected will blink in the display.

# Programming



Your microwave oven is now plugged in and the clock is set.

Open the door with the handle. Set the dish inside, close the door.

If the door is not properly shut, the appliance will not operate.

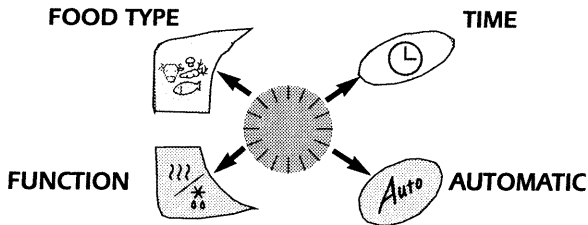
The following keys are used for the various programs :





- 3 beeps announce the end of a program. The beeps are repeated every minute for 10 minutes until you open the door.
- If you think there is insufficient space for the dish to turn freely inside the oven, press the **STOP TURNTABLE** key  before or during the program.
- If there is an error in the programming, press the **CANCEL** key  twice.

You may choose amongst the following programs :

## Express program

- ▼ set the program time (ex. 2 minutes) with the selector knob.

The functions  &  blink alternately to indicate that the express program (900 W) is set.

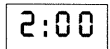
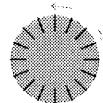

- ▼ Press **START** .

# Programming

## Programming with the function key

▼ Press the **FUNCTION** key, make your selection.  
With this key, the **SIMMER** setting  is available.

▼ Press the **TIME** key, set the program time with the selector knob.

▼ Press **START** .

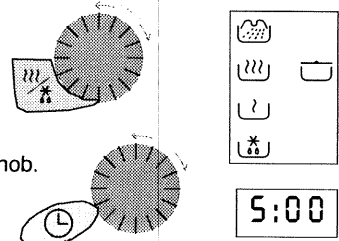

## Programming with the food type key

▼ Press the **FOOD TYPE** key, make your selection.

▼ Press the **FUNCTION** key, make your selection;  
the correct microwave power setting will be programmed  
according to the food type selected.

▼ Press the **TIME** key, set the program time with the selector knob.

▼ Press **START** .

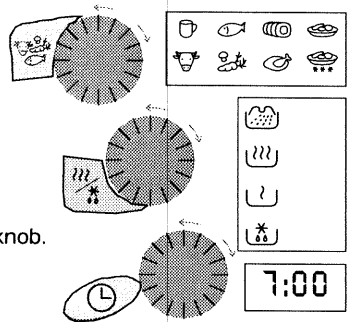

# Auto Programming

## Automatic programming

With the *Auto* key, the program time is set *automatically*  
according to the weight of your food item.

▼ Press the **FOOD TYPE** key, make your selection.

▼ Press the **FUNCTION** key, make your selection.

▼ Press the *Auto* key; **50 g** flashes,  
use the selector knob to indicate the weight of your food item.

▼ Press **START** .

The appropriate time is programmed *automatically*.

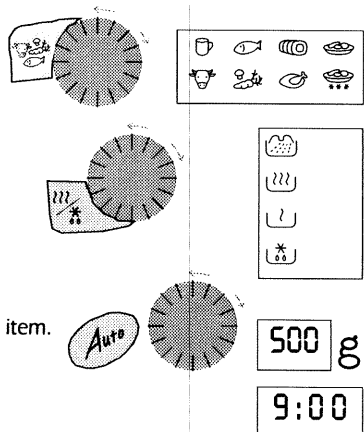

## The grill function



This function enables you to brown dishes such as gratins or meat. It may be used before or after cooking, as called for in the recipe.

### ■ The grill folds down for easy cleaning :



1 - **Horizontal position**: for cooking au gratin, grilled food laid flat.

2 - **Vertical position** : for cleaning the oven.

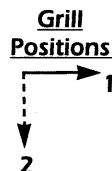
**Always allow the grill to cool off 25 minutes before touching it.**



■ After grilling make sure to use an oven mitt to handle dishes, and remember to use only oven proof cookware such as ceramic dishes or heat resistant glass.

■ The dual level grill offers you a choice between : **HIGH GRILL**  (press the GRILL key once) and **LOW GRILL**  (press twice).

As a rule, use the **HIGH GRILL level to grill meat and fish and the LOW GRILL level** with the simultaneous microwave+ grill function for gratins and to brown delicate dishes.

## The microwave + grill function



This function enables you to use the microwaves and grill **simultaneously**, for rapid cooking.

■ 2 grill levels and 3 microwave power settings may be used with this function.

### The Rack

for use with the **grill** function, to brown shallow dishes. When used with the simple or combined microwave functions, it must be positioned on the center of the turntable. Metal dishes may be used on the rack only with the simple grill function. However, you can heat a dish in an aluminum tray if it is isolated from the rack atop a plate.

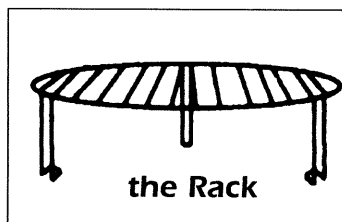



## Programming the grill





### Using the dual-level grill

- Press the **GRILL** key once to select **HIGH GRILL** , press twice to select **LOW GRILL** .

Set the program time and press **START** .

Press the **GRILL** key a third time to stop the grill functioning.

### Using the microwave + grill functions simultaneously

- Select the **FOOD TYPE**  with the selector knob. Select the **FUNCTION** , microwave + grill . The appropriate microwave power setting and the grill level will be automatically adjusted according to your food type.
- In the event the food item you wish to cook does not correspond to any of the proposed food categories, select the microwave + grill . A medium microwave power setting and high grill level will be programmed.







## Childlock

If after having entered a program and closed the door you wait longer than 30 seconds before pressing the **START** key , the oven will not operate and the message **SECU** will appear in the display window, to prevent start-up of an empty oven.

In order for the oven to operate, open and then close the door and press the **START** key. Otherwise, press the **CANCEL** key  and reprogram.

## Recommendations

### **WHILE THE OVEN IS OPERATING :**

- If you used the time or *Auto* key,  
➤ you may change the program length at any time.
- You may stop or start the turntable revolving during a program by pressing the **TURN-TABLE STOP** key .
- To change the food type or function selection, press the **CANCEL** key  twice and program again.
- If you open the door before the end of the program, shut the door and press the **START** key  to continue the program.
- When using the defrost function  a beep indicates the mid-point of the program (the oven continues to operate); to obtain the best results, turn the food at this time, close the door and press the **START** key  to continue the second half of the program.
- If you remove a dish before the end of the program, press the **CANCEL** key  twice to erase the program.

### **REMARKS :**

- If you wait longer than 3 minutes to press the **START** key  after having entered a program, it will be cancelled (the clocktime will be displayed).

## Care & cleaning

- Regular maintenance of your oven will keep it in sound operating condition. To prevent heavy soiling, it is preferable to cover recipients whenever possible.
- Make sure the work surface on which the microwave oven sits is always kept clean as surrounding dirt/dust could enter and damage your appliance.
- Clean with a damp, soapy sponge both on the inside and outside, with special attention to the door seal and front of the cavity which must be kept clean at all times. If these surfaces are damaged because they become excessively dirty, call in a specialised technician before using your oven.



- In the event of bad odors or caked-on dirt, boil water containing lemon juice or vinegar in a cup for 2 minutes and clean the walls with a little dishwashing liquid.
- For those ovens with grill or convection heat functions, the top and rear air vents become very hot. Do not touch these parts after use; wait till the appliance has cooled down in order to clean it. Use a fine steel wool pad on the metal parts.

- The turntable can be removed for cleaning. Wells are provided on both sides for easy access.

If you remove the drive shaft, do not allow water to enter the motor shaft hole.

Be sure to put the turntable, the drive shaft and the wheel support back in their proper place.

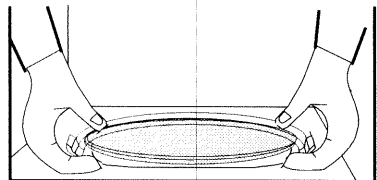

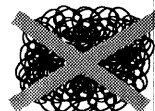

- Do not use abrasives, alcohol or solvents as they are liable to damage the oven.



# Troubleshooting guide

## Problem

## Suggestion

- |   |   |
|---|---|
| ▼ The message "SECU" is displayed   | ▲ Cancel childlock : open then shut the door and press the <b>START</b> key  .   |
| ▼ The time counts down, but the appliance does not function the turntable does not rotate, the light does not come on and the food is not heated) | ▲ Press the <b>TURNTABLE OFF</b> key  for 5 seconds.   |
| ▼ The microwave oven is noisy when operating.   | ▲ Adjust the front left foot.<br>Clean the wheels and the well area beneath the turntable.  |
| ▼ Condensation forms on the door glass  | ▲ Clean the vents under the appliance.  |
| ▼ The grill element smokes when it heats up.  | ▲ Clean all cooking residue from the grill element.   |
| ▼ The turntable does not revolve correctly  | ▲ Clean the wheels and the well beneath the turntable.  |
| ▼ The microwave programs do not produce the desired results.  | ▲ Clean the vents under the appliance.<br>Make sure that you use only containers which are suitable for microwave cooking.  |
| ▼ The appliance produces sparks.  | ▲ Check whether the wheel support is correctly positioned.<br>Thoroughly clean the appliance :<br>remove any greasy deposits, cooking residue, etc...<br>Move any metal objects away from the oven walls.<br>Never use metallic containers with the rack. |

## After-sales service

- If the equipment has sustained any damage :
  - **Check that the door is not deformed.**
- If the oven does not operate, before calling the repairman :
  - Check the electrical supply.
  - Check that the door is properly closed.
  - Check your programming.

**CAUTION : never attempt to repair  
your oven yourself.**

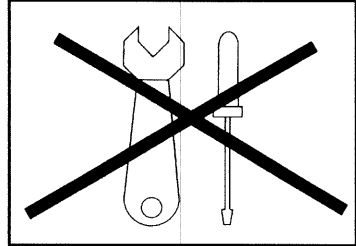

**WARNING :** it is dangerous for anyone other than qualified personnel to make any repairs requiring removal of the cover providing protection from exposure to microwave energy.

**Only a specially trained technician is qualified  
to repair your microwave oven**

# PORTUGUÊS

Manual de instruções ..... pág 39

# Índice

Instalação / Ligação . . . . .	.40
Um pouco de técnica . . . . .	.41
Conselhos importantes . . . . .	.42
Apresentação . . . . .	.44
Quadro de comando . . . . .	.45
Hora do relógio / Equivalência das potências . . . . .	.46
O visualizador & o selector . . . . .	.47
Programação . . . . .	.48
A função grelhador / A função micro-ondas + grelhador . . . . .	.50
Programação do grelhador . . . . .	.51
Segurança para as crianças / Recomendações . . . . .	.52
Limpeza . . . . .	.53
Problemas => Conselhos . . . . .	.54
Serviço Após-Venda . . . . .	.55

Ler com cuidado este manual de utilização.  
Conselhos importantes relativos à segurança,  
l'instalação/lugar, utilização do aparelho.

# Instalação

## ANTES DE FAZER A LIGAÇÃO

- Verificar que o aparelho não sofreu nenhuma avaria aquando do transporte (porta ou junta deformada, etc.). Se verificar qualquer dano, antes de toda utilização, contactar o seu vendedor.
- Verificar a tensão da rede. No caso de subtensão PERMANENTE (200-210 volts), consultar o seu instalador electricista.

## LOCALIZAÇÃO

- Este aparelho destina-se a ser pousado (ou encastrado conforme o caso) numa bancada situada a pelo menos 85 cm do chão.
- Colocar o aparelho numa superfície plana e horizontal. Escolher um local afastado de qualquer fonte de calor ou de vapor. Para assegurar a boa estabilidade do aparelho, o pé dianteiro esquerdo é regulável (5 posições). Rodá-lo para subir ou descer o forno.
- Verificar a livre circulação do ar em torno do forno.

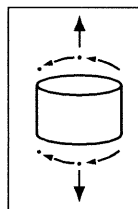

Deixar um espaço suficiente entre o aparelho e a parede de :

- 5 cm de lado,
- 10 cm na traseira e
- 14 cm sobre o seu aparelho.

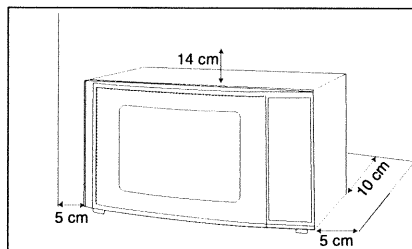

## LIGAÇÃO ELÉCTRICA

- Não colocar nada sobre o forno de modo a não tapar os orifícios de ventilação situados atrás do forno.
- Alguns aparelhos podem ser encastrados. Para obter ao kit correspondente, consulte o seu vendedor.
- A fixa da tomada de corrente deve ser acessível após instalação.
- A instalação deve estar protegida com um fusível térmico de 16 Amperes.
- Utilize obrigatoriamente uma tomada de corrente com ligação à terra e conforme às normas de segurança em vigor.
- Prever na instalação eléctrica um dispositivo acessível ao utilizador que possa cortar o aparelho da rede e cuja abertura do contacto seja de pelo menos 3 mm a nível de todos os pólos.
- Não fazer funcionar o forno se o cabo de alimentação ou a ficha estiverem estragados. Nesse caso, chamar um técnico especializado formado pelo fabricante.

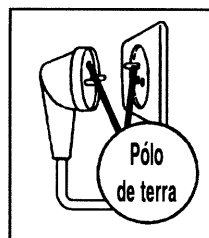
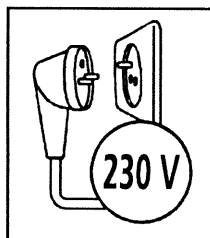



## Um pouco de técnica

As micro-ondas utilizadas para a cozedura são de ondas electro-magnéticas; elas existem no nosso meio ambiente como as ondas radio-eléctricas, a luz, os raios infra-vermelhos. A sua frequência situa-se na banda dos 2450 MHz.

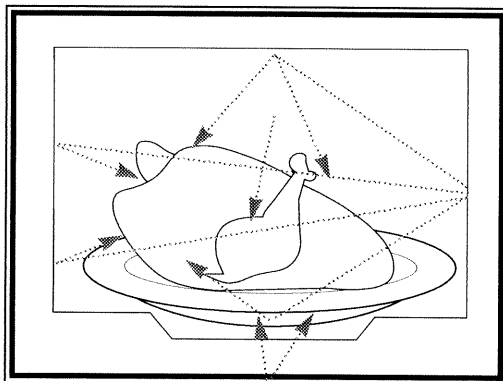

### O Seu comportamento :

- São reflectidas pelos metais.
- Atravessam todos os materiais.
- São absorvidas pelas moléculas de água, de gordura e de açúcar.

Quando um alimento é exposto as micro-ondas, segue-se uma agitação de moléculas que as faz vibrar à velocidade de 2 bilhões 450 milhões de vez/segundo, o que provoca um aquecimento.

A profundidade de penetração das ondas no alimento é de mais ou menos 2,5 cm, e se o alimento é mais espesso, a cozedura por dentro far-se-à por condução como na cozedura tradicional.

Convém saber que as micro-ondas provocam no interior do alimento um simples fenómeno térmico e que elas não são nocivas para a saúde.

## Conselhos importantes

- O seu aparelho destina-se exclusivamente a um uso doméstico para cozer, aquecer ou descongelar alimentos. O fabricante não é responsável de uma utilização não conforme.
- Para evitar a deterioração do seu aparelho, nunca fazer funcionar em vazio e sem prato.
- Antes de qualquer utilização, verifique se os recipientes são adaptados ao uso no micro-ondas (por exemplo; vidro para fogo, porcelana...).
- Vigiar frequentemente o forno quando os alimentos são aquecidos ou cozidos em recipientes plásticos, em papel ou outro material combustível, de maneira a evitar os riscos de inflamação.
- Não é aconselhado usar recipientes metálicos, garfos, colheres ou facas, assim como laços e agramos em metal para sacos de congelação. Contudo, ocasionalmente, pode aquecer alimentos acondicionados em embalagens de alumínio de pequena altura (máximo 4 cm) sem a tampa. No entanto, o tempo de aquecimento será um pouco mais longo. Neste caso, ter o cuidado de que o recipiente esteja bem colocado no centro do prato de vidro e que ele não esteja a menos de 1 cm das paredes metálica ou da porta do aparelho.
- Para as crianças é obrigatório :
  - aquecer os biberões, sem a teta, agitar o líquido e verificar a sua temperatura nas costas da mão antes de o dar à criança.
  - Misturar e verificar a temperatura dos alimentos para as crianças antes do consumo, de maneira a evitar queimaduras internas graves.
- Não mexer nos orifícios da fechadura da face frontal de maneira a evitar danos que necessitariam de uma intervenção técnica.

## Conselhos importantes

- Recomenda-se cobrir os alimentos na maior parte dos casos : eles serão mais saborosos e o aparelho continuará limpo. Entretanto, antes de cozer os alimentos ou de aquecer os líquidos num recipiente térmico, retirar a rolha ou a tampa para evitar o risco de explosão.
- É proibido aquecer ou cozer ovos com casca, em panela ou prato. Os ovos podem rebenotar e provocar queimaduras graves ou danificar irremediavelmente o forno.
- Quando do aquecimento de líquidos, a temperatura de ebulição pode ser atingida sem que as bolhas de vapor típicas subam à superfície. A fim de evitar o transbordamento e o risco de queimaduras aguardar durante 20 segundos antes de tirar o recipiente do aparelho ou de aí introduzir qualquer outra coisa de maneira a impedir que o líquido salpique subitamente.
- Quando de pequenas quantidades (salsicha, croissant...) pousar um copo com água ao lado do alimento.
- Tempos longos podem secar o alimento e carbonizá-lo. Para evitar tais incidentes, nunca utilizar os mesmos tempos previstos para uma cozedura em forno tradicional.
- Se aparecer fumo, manter a porta do forno fechada, apagar o forno ou desligar da tomada eléctrica.
- Permita que as crianças utilizem o aparelho apenas depois de as ter esclarecido sobre o funcionamento do aparelho e de as ter alertado para o perigo que representa o funcionamento indevido.

## Apresentação

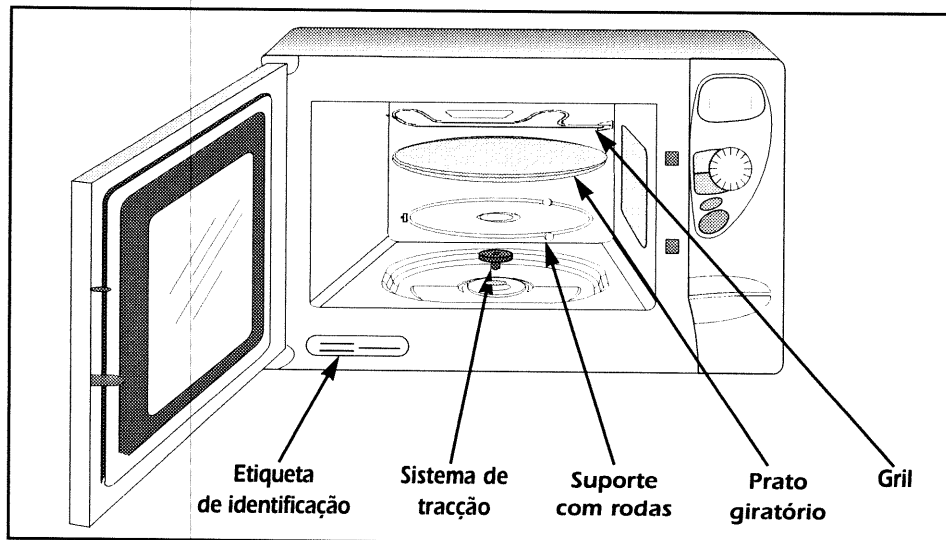

### ■ PRATO GIRATORIO :

permite cozer o alimento de forma homogénea e sem manipulação.

- É guiado na sua rotação pelo eixo de accionamento e o suporte com rodas, gira em ambos os sentidos.
- Se não girar, verificar se todos os elementos estão bem instalados.
- Pode ser utilizado como assadeira.
- Para o retirar, pegue nele utilizando as zonas de acesso previstas para esse efeito.

■ **PRATO NA POSIÇÃO PARADA :** permite utilizar assadeiras grandes em toda a superfície do forno. Nesse caso, é necessário rodar o prato ou misturar o conteúdo a meio do cozinhado.

### ■ O SUPORTE O ROULETAS :

Naõ faça tournar manualmente o suporte o rouletas, vce risca da dteriorar o sistema do trabalho. En casa de m circulao esteja certo que no  nada que estorve en baixo da mesa do trabalho.

# Quadro de Comando

## A O visualizador :

facilita-lhe a programação visualizando : as categorias de alimentos e funções, o tempo ou o peso programado, e a hora.

## B O selector :

permite escolher o alimento, a função, o tempo ou o peso.

## C A tecla "ALIMENTOS" :

permite escolher a categoria de alimento, com a ajuda do selector.

## D A tecla "FUNÇÕES" :

permite escolher a função apropriada, com a ajuda do selector.

## E A tecla "TEMPO" :

permite programar o tempo com a ajuda do selector.

## F A tecla "Auto" :

programa automaticamente o tempo necessário conforme o peso do alimento escolhido.

## G A tecla "PARAGEM PRATO" :

permite a paragem do prato giratório.

## H A tecla "GRELHADOR" :

permite seleccionar um dos 2 níveis de potência do grelhador.

## I A tecla "PAUSA/ANULAÇÃO" :

permite interromper ou apagar um programa em curso (uma pressão para PAUSA, duas pressões para ANULAÇÃO).

Permite igualmente colocar o relógio à hora.

## J A tecla "INÍCIO" :

permite iniciar o seu programa.

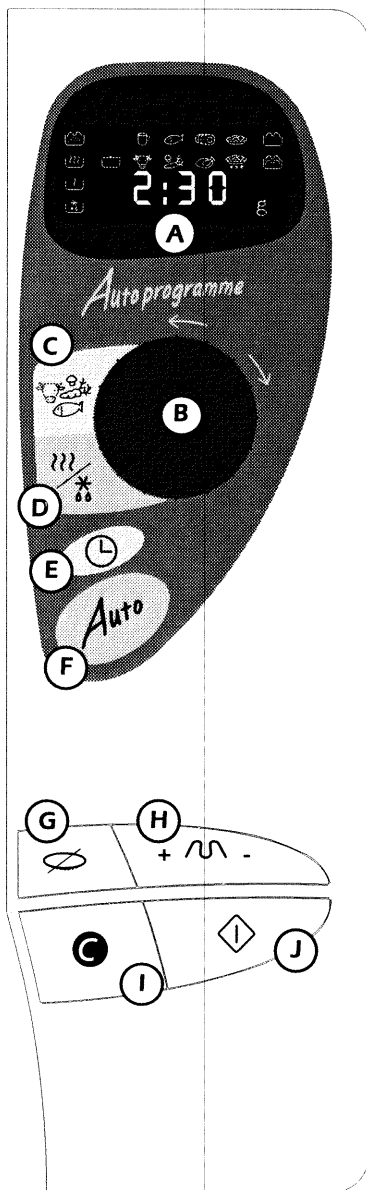

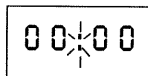

## Hora do relógio

Após a ligação do seu aparelho ou um corte de corrente, o relógio indica 00:00, os dois pontos : piscam.





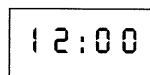
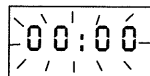

**Para regular a hora no relógio :**

- Pressionar durante 5 segundos a tecla PAUSA/ANULAÇÃO .
- Programar o relógio marcando a hora desejada (o selector).
- Validar pressionando simplesmente a tecla ANULAÇÃO , o relógio fica regulado.



## Equivalência das potências

FUNÇÃO	UTILIZAÇÃO
 <b>DESCONGELAÇÃO</b>	Para descongelar todos os alimentos. Para terminar as cozeduras delicadas ou para cozer lentamente.
 <b>COZER A LUME BRANDO</b>	Para terminar as preparações começadas em COCÇÃO FORTES, tais como feijão, lentilhas, doces de leite. (Esta função é disponível quando se começa a programação ao seleccionar a função).
 <b>AQUECIMENTO</b>	Para aquecer todos os alimentos líquidos ou sólidos, assim que pratos feitos frescos ou congelados.
 <b>COCÇÃO FORTES</b>	Para cozinhar legumes, peixes, aves e sopas.
<b>Potência restituída: 900 W</b>	

**Quando selecciona um alimento, a potência necessária é programada automaticamente.**

## O visualizador & selector

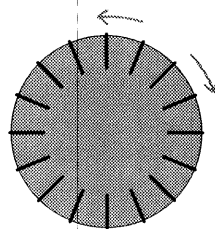
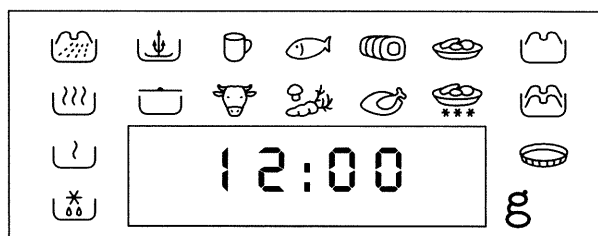

**O visualizador e o selector guiam-lhe na escolha :  
dos alimentos**

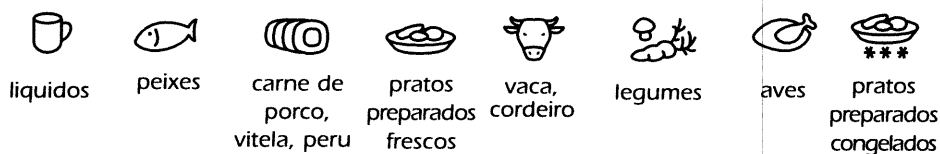

### las funções

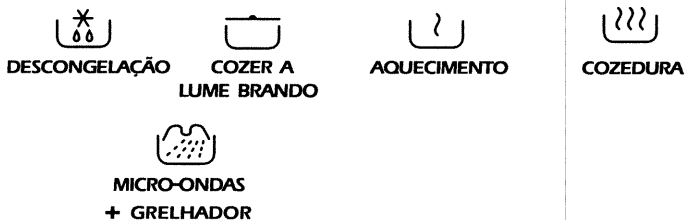

### do grelhador 2 níveis

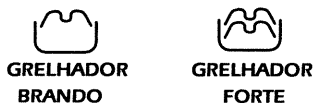

**do peso** para um programação *Auto* g

**do tempo de programação** (ou relógio) 12:00

**O alimento ou a função durante a selecção pisca.**

# Programação



**O seu aparelho está agora ligado e à hora.**

Abra a porta com a ajuda da pega. Coloque o alimento dentro do aparelho, feche a porta.

Se a porta não está bem fechada, o aparelho não funciona.

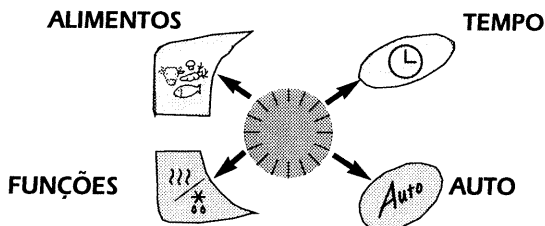

**Faça a sua programação com as teclas :**



- Quando o aparelho pára, um sinal sonoro triplo indica o fim do programa. Esse sinal é repetido todos os minutos durante dez minutos até a abertura da porta.
- Se pensa que o prato não pode rodar, utilize a tecla PARAGEM PRATO  antes ou durante o programa.
- No caso de erro de programação, premir duas vezes a tecla ANULAÇÃO .

**As programações à sua disposição :**

## Programação Expresso

- ▼ Programar o tempo desejado (ex. 2 minutos) com a ajuda do selector As funções  e  piscam para indicar a potência expresso 900 W.

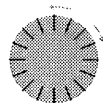



2:00

- ▼ Premir a tecla INÍCIO .



# Programação

## Programação através da tecla função

- ▼ Premir a tecla **FUNÇÕES**, faça a sua escolha.  
Neste modo, a função **COZER A LUME BRANDO**  é disponível.
- ▼ Premir a tecla **TEMPO**,  
programar o tempo desejado com a ajuda do selector.
- ▼ Premir a tecla **INÍCIO** .

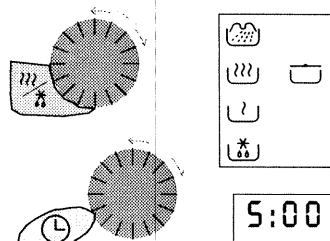

## Programação através da tecla alimento

- ▼ Premir a tecla **ALIMENTOS**, faça a sua escolha.
- ▼ Premir a tecla **FUNÇÕES**, faça a sua escolha;  
a potência micro-ondas será adaptada ao alimento escolhido.
- ▼ Premir a tecla **TEMPO**,  
programar o tempo desejado com a ajuda do selector.
- ▼ Premir a tecla **INÍCIO** .

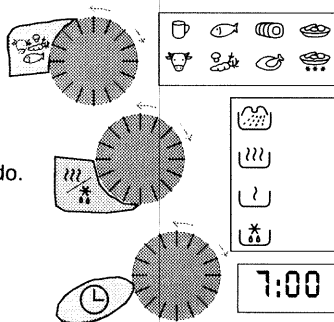

# Programação *Auto*

## Programação automática

Com a tecla *Auto*, o tempo é calculado *automaticamente* em função do peso do alimento.

- ▼ Premir a tecla **ALIMENTOS**, faça a sua escolha.
  - ▼ Premir a tecla **FUNÇÕES**, faça a sua escolha;
  - ▼ Premir a tecla *Auto*; **50 g** pisca,  
pedindo-lhe que indique o peso com a ajuda do selector.
  - ▼ Premir a tecla **INÍCIO** .
- O tempo adequado visualiza-se automaticamente.**

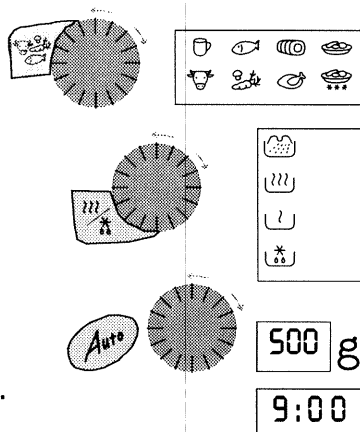

## A função grelhador

Esta função permite alourar os alimentos como gratinados e carne... Ela pode ser utilizada antes ou depois da cozedura, conforme as receitas.



- Grelhador 2 posições :

### Posições o grelhador

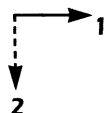
1. Grelhador horizontal : para gratinados e grelhados em plano.
2. Grelhador vertical : para limpeza.



É necessário esperar 25 minutos depois de utilizar antes de tocar no grelhador.

- Quando da utilização do grelhador, é necessário proteger as mãos para tirar os pratos e utilizar recipientes que suportam as temperaturas elevadas, como os de vidro ou de cerâmica.
- Tem à sua disposição 2 níveis de grelhador : GRELHADOR FORTE  (com uma pressão na tecla GRELHADOR) e GRELHADOR BRANDO  (duas pressões).  
Em regra geral, utilize o nível GRELHADOR FORTE para grelhar carnes e peixes, e utilize os níveis do grelhador GRELHADOR BRANDO em função micro-ondas para gratinar bem como para dourar os alimentos mais delicados.

## A função micro-ondas + grelhador

Esta função dá a possibilidade de utilizar simultaneamente as micro-ondas e o grelhador, permitindo assim uma cozedura rápida.

- Tem à sua disposição 2 níveis de grelhador e os 3 funções micro-ondas.

### A GRELHA

A GRELHA : Na função grelhador, permite dourar os alimentos com pouca altura.

Durante a utilização na função micro-ondas ou função simultanea micro-ondas + grelhador, deve estar obrigatoriamente bem posicionada sobre o prato em vidro. A grelha não deve ser nunca usada com recipientes metálicos na função micro-ondas.

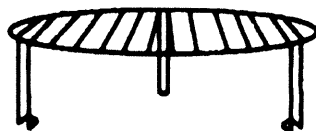



A Grelha





No entanto, pode aquecer um alimento numa embalagem em alumínio isolando-a da grelha com um prato.

## Programação do grelhador

### Utilização do grelhador 2 níveis de potência

- Premir uma vez a tecla GRELHADOR para seleccionar GRELHADOR FORTE , 2 vezes para seleccionar GRELHADOR BRANDO . Programar o tempo escolhido e premir INÍCIO . Uma terceira pressão na tecla GRELHADOR pára o grelhador.

### Utilização da função micro-ondas + grelhador simultâneo :

- Selecione o seu ALIMENTO  entre as categorias propostas. Selecione em seguida a FUNÇÃO  micro-ondas + grelhador . A potência micro-ondas bem como o nível de grelhador será automaticamente adaptada ao seu prato.
- Se ao seu alimento não corresponde nenhuma categoria proposta, selecione a FUNÇÃO micro-ondas + grelhador . Nesse caso, uma potência micro-ondas média e o grelhador forte são pré-programadas.







## Segurança para as crianças

Se esperar mais de 30 segundos antes de pressionar a tecla **INÍCIO** , e depois de ter efectuado a programação do forno e ter fechado a porta, o forno não arranca e o mostrador indica **SECU** a fim de impedir o funcionamento do aparelho vazio.

Para pôr o forno a trabalhar, abrir e fechar a porta e pressionar a tecla **INÍCIO** .

## Recomendações

### DURANTE A COZEDURA :

- Se fez uma programação através da tecla **TEMPO** ou com a tecla *Auto* :
  - pode modificar a duração a qualquer momento.
- Pode parar ou arrancar o prato giratório durante a cozedura premindo a tecla **PARAGEM PRATO** .
- Para modificar a escolha da **FUNÇÃO** ou do **ALIMENTO**, deve premir duas vezes a tecla **PAUSA / ANULAÇÃO**  e recomeçar a programação.
- Quando abrir a porta antes do fim do programa, pressionar a tecla **INÍCIO**  para pôr o aparelho a funcionar.
- Para um melhor resultado, com a função descongelação  uma campainha toca a meio-descongelação (sem que o forno pare). Se quiser, voltar o alimento, fechar a porta e pressionar a tecla **INÍCIO**  para pôr novamente o forno a trabalhar.
- Quando retirar o alimento antes do fim do programa, para anular os dados marcados premir duas vezes a tecla **PAUSA/ANULAÇÃO** .

### NOTA :

- Se, após ter começado uma programação, não premir a tecla **INÍCIO**  ao cabo de três minutos, o programa será anulado (a hora visualizar-se-á novamente).

# Limpeza

- A limpeza regular do aparelho permite conservá-lo em bom estado de funcionamento. Para evitar sujidades demasiado importantes, é necessário cobrir a maior parte das vezes os alimentos.
- Verificar se a zona onde o forno está pousado está bem limpa; a aspiração das sujidades poderia causar danos.

- Utilizar uma esponja húmida com sabão, para limpar o interior e o exterior do forno, a porta e o recinto.



- No caso de cheiro ou de forno sujo, fazer ferver água com sumo de limão ou vinagre numa taça durante 2 minutos e limpar as paredes com um pouco de detergente de louça.
- Se o forno tiver uma função grelhador ou calor circulante, limpar quando o forno estiver ainda morno, com um esfregão em palha de aço fina e sabão, tendo cuidado com a temperatura do forno para evitar queimaduras.

- O prato pode ser retirado para limpeza.

Para o retirar, pegue nele utilizando as zonas de acesso previstas para esse efeito.

Se retirar o sistema de accionamento, evitar fazer penetrar água no furo do eixo do motor.

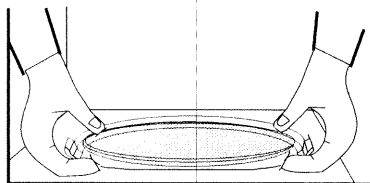

Não esquecer de colocar o eixo de accionamento, o suporte com rodas, e o prato giratório.

- Os contornos da porta e da caixa devem estar sempre limpos. Se, devido a excesso de sujidades, essas superfícies ficarem estragadas, chamar um técnico especializado antes de utilizar o aparelho.

- Não é aconselhado usar produtos abrasivos, álcool ou diluente pois podem deteriorar o aparelho.

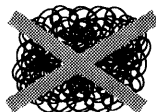



# Problemas => Conselhos

## Problemas

- ▼ O aparelho visualiza “ S E C U ”
- ▼ O tempo começa a descontar mas o aparelho não funciona (o prato giratório não roda, a iluminação não acende e o alimenton não é aquecido)
- ▼ O forno está demasiadamente barulhento
- ▼ Constata baço no vidro
- ▼ Sai fumo do grelhador no início do programa
- ▼ O prato não gira correctamente
- ▼ O alimento não aquece em programa micro-ondas
- ▼ O aparelho produz faíscas

## Conselhos

- ▲ Anular a segurança criança : abrir em seguida fechar a porta e premir a tecla INÍCIO .
- ▲ Premir a tecla PARAGEM PRATO  durante 5 segundos.
- ▲ Ajustar o pé regulável.  
Limpar os rolamentos e as suas zonas debaixo do prato giratório
- ▲ Limpar a grelha de aspiração debaixo do aparelho.
- ▲ Retirar todos os depósitos de resíduos de cozedura no elemento aquecedor.
- ▲ Limpar os rolamentos e as suas zonas debaixo do prato giratório
- ▲ Limpar a grelha de aspiração debaixo do aparelho.  
Verificar se os utensílios convêm ao forno micro-ondas
- ▲ Verificar se o suporte de rolamentos está bem posicionado. Limpar bem o aparelho: as gorduras e as partículas de cozedura. Afastar qualquer elemento metálico das paredes do forno.  
Nunca utilizar elementos metálicos com o compartimento.

## Serviço Após-Venda

- Se o aparelho sofreu qualquer avaria :
  - Verificar se a porta não está deformada.
- Se o aparelho não funcionar, antes de chamar o reparador:
  - Verificar a alimentação eléctrica.
  - Verificar o fecho correcto da porta.
  - Verificar a programação.

**ATENÇÃO: nunca tentar fazer a intervenção você mesmo.**

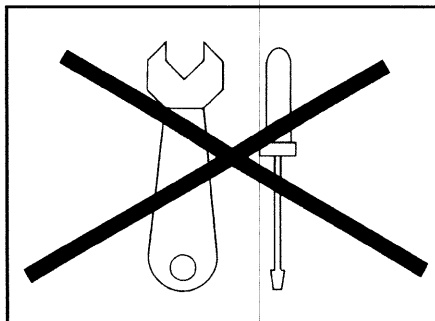

**PERIGO :** Qualquer intervenção de assistência ou de avaria em que seja necessário tirar a tampa protetora contra a exposição à energia do micro-ondas deve ser feito por pessoa competente.

Em caso de avaria, o seu forno só poderá ser reparado pelo Serviço Técnico Autorizado, especialmente estabelecido pelo fabricante.

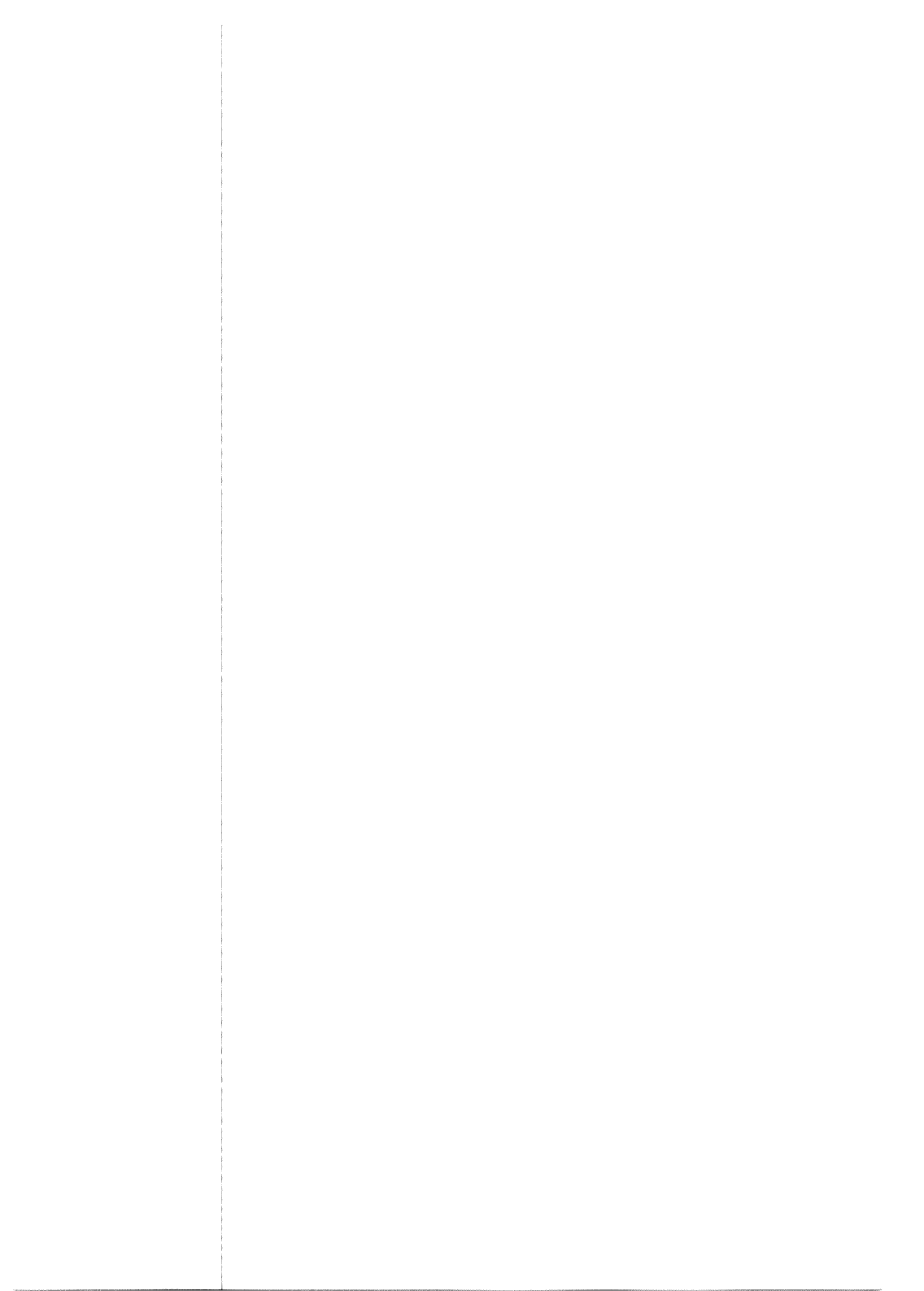



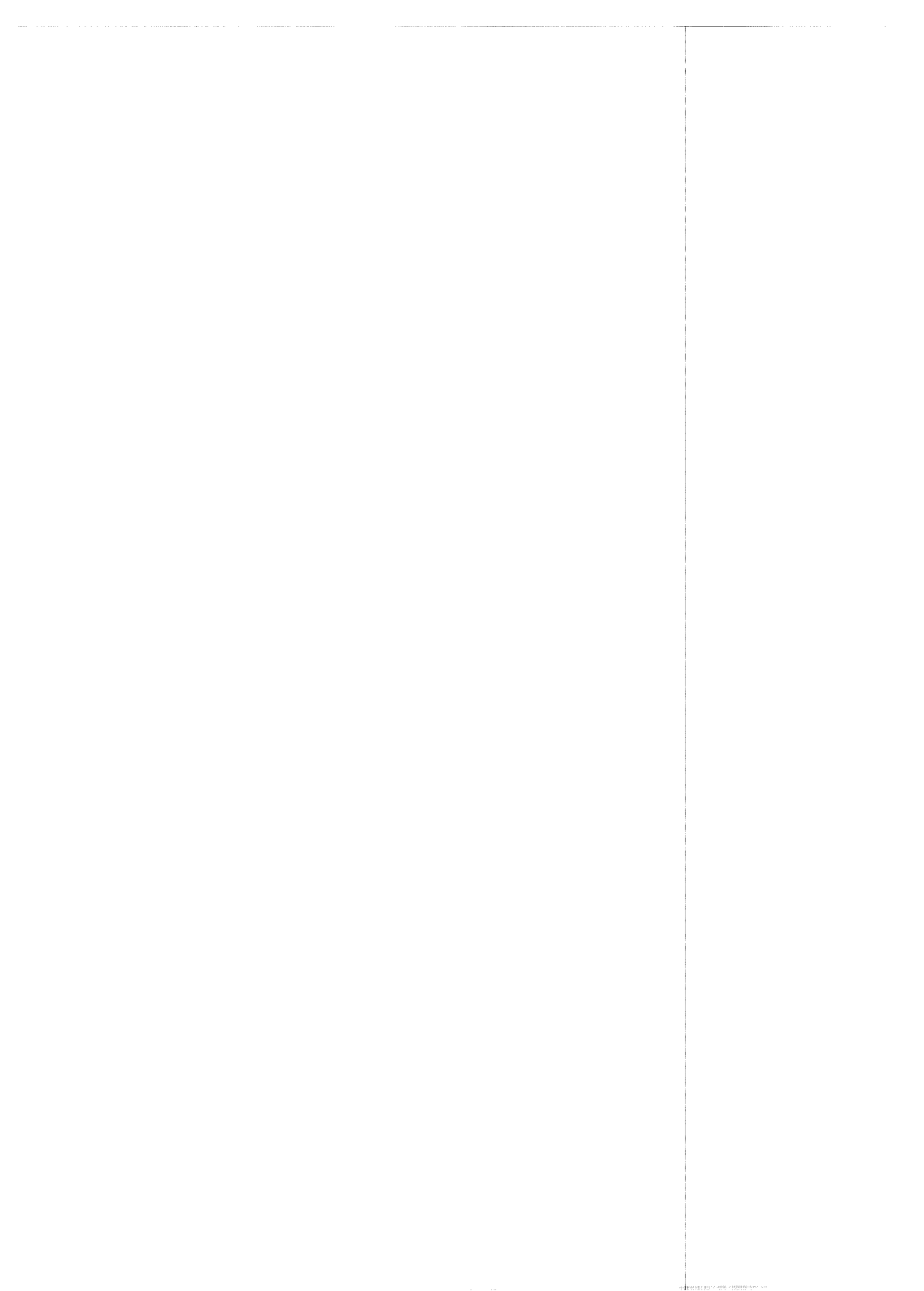

Réf. 9818002- 07/99

87x3010