

Panasonic

Operating Instructions

Digital Cordless Phone

Model No. **KX-TCD300FX**



SMS



This unit is compatible with Caller ID and SMS. To use these features, you must subscribe to the appropriate service of your service provider.

Charge the batteries for about 7 hours before initial use.

Please read these operating instructions before using the unit and save them for future reference.

Introduction

Introduction

Thank you for purchasing a new Panasonic digital cordless phone.

For your future reference

Attach or keep original receipt to assist with any repair under warranty.

Serial No. (found on the bottom of the base unit)
Date of purchase
Name and address of dealer

Note:

- In the event of problems, you should contact your equipment supplier in the first instance.

Declaration of Conformity:

- Panasonic Communications Co., Ltd. declares that this equipment is in compliance with the essential requirements and other relevant provisions of Radio & Telecommunications Terminal Equipment (R&TTE) Directive 1999/5/EC.

Declarations of Conformity for the relevant Panasonic products described in this manual are available for download by visiting:

<http://www.doc.panasonic.de>

Contact:

Panasonic Services Europe GmbH
Panasonic Testing Centre
Winsbergring 15, 22525 Hamburg, F.R. Germany

Trademarks:

- Eaton and LetterWise are trademarks of Eaton Ergonomics, Inc.

Feature highlights

Feature highlights



Colour display

The handset's colour display allows you to customise the handset to your liking. You can customise the handset by selecting the "wallpaper" pattern shown on the display in standby mode (page 22). If you set the wallpaper to "OFF", the display colour (page 22) setting will be used instead.



Phonebook

The phonebook allows you to make calls without having to dial manually. You can add 200 names and phone numbers to the phonebook, assign each phonebook entry to the desired category, and search for phonebook entries by name or category.



Phonebook category

If you subscribe to Caller ID service, phonebook categories (page 16) can help you identify who is calling by using different display colours and ringtones for different categories of callers (page 30).



Night mode

Night mode allows you to select a block of time during which the handset/base unit will not ring, useful if you do not want to be disturbed, for example, while sleeping.

Night mode can be set independently for the handset (page 21) and base unit (page 26).



SMS (Short Message Service)

SMS allows you to send and receive text messages between other fixed-line and mobile phones that support compatible SMS networks and features. SMS features are available only after subscribing to Caller ID and/or appropriate service (page 32).



Polyphonic ringtones for handset

You can change the ringtone heard when the handset rings for outside calls and intercom calls. You can choose from 6 ringtones and 14 melody tones (page 20).

Table of Contents

Preparation

Accessory information	5
Important information	6
Controls and displays	7
Connections	9
Battery installation	10
Battery charge	10
Screen saver mode	11
Battery replacement	11
Turning the power on/off	11
Setting the date and time	12

Making/Answering Calls

Making calls	13
Answering calls	15

Phonebook

Using the phonebook	16
Copying phonebook entries to other handsets	18

Handset Settings

Guide to handset settings	19
Time settings	20
Ringer setup	20
Night mode	21
Display setup	22
Call options	23
Other options	23

Base Unit Settings

Guide to base unit settings	25
Ringer setup	26
Call options	27
Other options	28

Caller ID Service

Using Caller ID service	30
Caller list	31

SMS (Short Message Service)

Using SMS (Short Message Service)	32
Turning SMS on/off	32
Storing SMS message centre numbers	32
Sending a message	33
Receiving a message	34
Guide to SMS settings	35
Available character entries for SMS	36

Multi-unit Operation

Operating additional units	38
Registering a handset to a base unit	38
Intercom between handsets	40
Transferring calls between handsets, conference calls	40

Useful Information

Wall mounting	42
Available character entries	43
Troubleshooting	46
Specifications	50

Index

Index	51
-----------------	----

Preparation**Accessory information****Included accessories**

AC adaptor
PQLV19CE

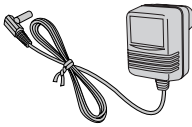

Telephone line cord

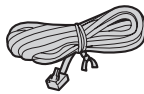

Rechargeable batteries
AAA (R03) size
HHR-4EPT



Handset cover

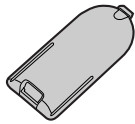

Operating instructions



Quick guide

**Additional/replacement accessories**

Model No.	Description
P03P	2 rechargeable nickel metal hydride (Ni-MH) batteries
KX-TCA130FX	Additional handset
KX-A272	DECT repeater

Preparation

Important information

General

- Use only the AC adaptor included with this product, noted on page 5.
- Do not connect the AC adaptor to any AC outlet other than a standard 220–240 V AC outlet.
- This product is unable to make calls when:
 - The portable handset battery(ies) need recharging or have failed.
 - There is a power failure.
 - The key lock feature is turned on.
 - The call bar feature is turned on (only phone numbers stored in the unit as emergency numbers can be called).
- Do not open the base unit or handset other than to replace the battery(ies).
- This product should not be used near emergency/intensive care medical equipment and should not be used by people with pacemakers.
- Care should be taken that objects do not fall onto, and liquids are not spilled into, the unit. Do not subject this product to excessive smoke, dust, mechanical vibration or shock.

Environment

- Do not use this product near water.
- This product should be kept away from heat sources such as radiators, cookers, etc. It should also not be placed in rooms where the temperature is less than 5 °C or greater than 40 °C.
- The AC adaptor is used as the main disconnect device. Ensure that the AC outlet is installed near the unit and is easily accessible.

Warning:

- To prevent the risk of electrical shock, do not expose this product to rain or any other type of moisture.

Location

- For maximum distance and noise-free operation, place your base unit:
 - Away from electrical appliances such as TVs, radios, personal computers or other phones.
 - In a convenient, high and central location.

Battery caution

- We recommend using the battery(ies) noted on page 5. **Use only rechargeable battery(ies).**
- Do not mix old and new batteries.
- Do not dispose of the battery(ies) in a fire, as they may explode. Check local waste management codes for special disposal instructions.
- Do not open or mutilate the battery(ies). Released electrolyte from the battery(ies) is corrosive and may cause burns or injury to the eyes or skin. The electrolyte may be toxic if swallowed.
- Exercise care when handling the battery(ies). Do not allow conductive materials such as rings, bracelets or keys to touch the battery(ies), otherwise a short circuit may cause the battery(ies) and/or the conductive material to overheat and cause burns.
- Charge the battery(ies) in accordance with the information provided in these operating instructions.
- Only use the included base unit (or charger) to charge the battery(ies). Do not tamper with the base unit (or charger). Failure to follow these instructions may cause the battery(ies) to swell or explode.

Preparation

Controls and displays

Controls

Handset

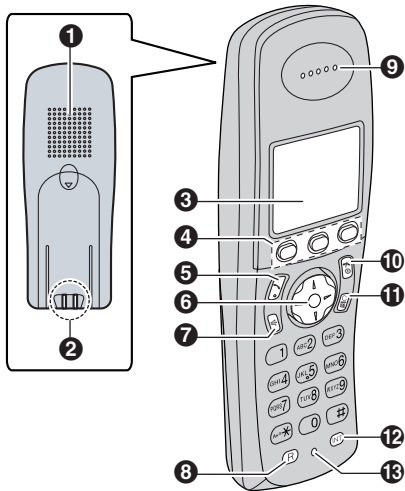

- ➊ Speaker
- ➋ Charge contact
- ➌ Display
- ➍ Soft keys
- ➎ [↶] (Talk)
- ➏ Navigator key
 - [▲][▼]: To search for the desired item in menus.
 - [▶]: To select the desired item or move the cursor to the right.
 - [◀]: To return to the previous screen or move the cursor to the left.
- ➐ [☎] (Speakerphone)
- ➑ [R] (Recall)
- ➒ Receiver
- ➓ [⏻] (Off/Power)
- Ⓜ [C/Ⓜ] (Clear/Mute)
- Ⓜ [INT] (Intercom)
- Ⓜ Microphone

Note:

- Up to 3 menu items can be displayed at a time. To select a menu item not shown on the current page, scroll up or down by pressing the navigator key, [▲] or [▼], respectively.

Base unit

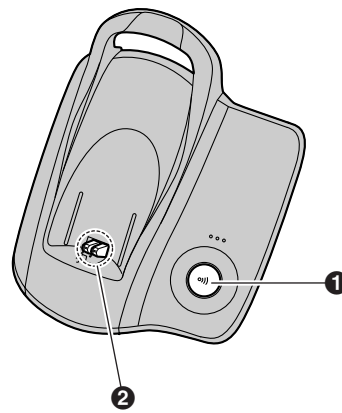

- ➊ [☎] (Page)
- ➋ Charge contact

Displays

Display icons

Various icons appear on the handset display to indicate the current status of the unit.

Display icon	Meaning
⏻	Within range of a base unit <ul style="list-style-type: none"> • When flashing: Handset is searching for base unit. (out of range of base unit, handset is not registered to base unit, no power on base unit)

Preparation

Display icon	Meaning
	Handset is accessing base unit. (intercom, paging, changing base unit settings, etc.)
	Handset is on an outside call.
	Call bar is on. (page 23)
	Missed call (Caller ID subscribers only; page 30)
	Batteries are charging.
	Battery strength
	Alarm is on. (page 20)
	Voice enhancer is set to high or low tone. (page 14)
	Ringer volume is off. (page 20)
	Night mode is on. (page 21)
[2]	Handset number: The left icon shows handset 2 example. (page 22)
-2-	Base unit number: The left icon shows base unit 2 example. (page 22)
	New SMS message received (SMS users only; page 34)
	Your written SMS message is over 160 characters. (SMS users only; page 33)
	SMS memory is full. (SMS users only)
	Line is being used by another handset.

Menu icons

When in standby mode, pressing the middle soft key reveals the handset's main menu. From here you can access various features and settings.

Menu icon	Menu/feature
	Caller List
	SMS (Short Message Service)
	Time Settings
	Handset Setup
	Base Unit Setup
	Display Setup

Soft keys

The handset features 3 soft keys. By pressing a soft key, you can select the feature or operation indicated by the soft key icon shown directly above it.



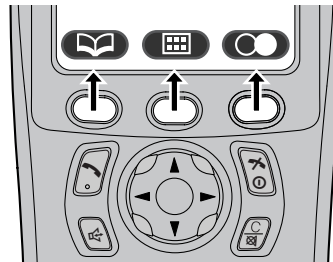



- Pressing the left, middle, or right soft key selects the leftmost, centre, or rightmost soft key icon respectively.
- The icons shown will vary depending on how you are using the unit.



Soft key icons

Soft key icon	Action
	Returns to the previous screen.
	Displays the main menu.
	Accepts the current selection.
	Displays a previously dialed phone number.
	Opens the phonebook.

Preparation

Soft key icon	Action
	Displays the phonebook search menu.
	Turns the key lock feature off. (page 14)
	Displayed when adding or editing a phonebook entry, or when writing an SMS message.
	Inserts a dialling pause. (page 15)
	Erases the selected item.
	Displayed when the soft key has no function.

Connections

When the AC adaptor is connected, a short beep will be heard. If it is not heard, check the connections.

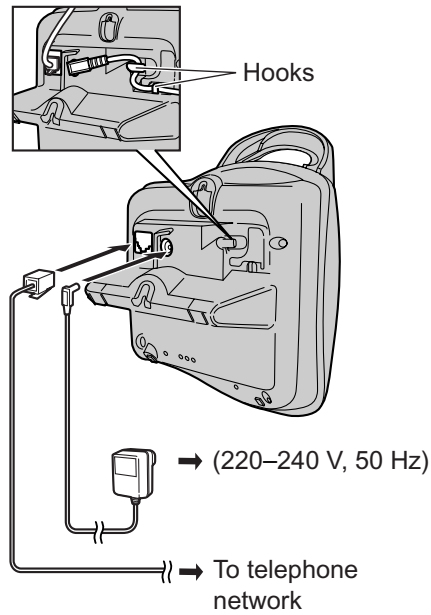

Important:

- Use only the AC adaptor and telephone line cord supplied with this unit.

Note:

- After connection, you must charge the batteries to make or answer calls (page 10).
- Never install telephone wiring during a lightning storm.
- The AC adaptor must remain connected at all times. (It is normal for the adaptor to feel warm during use.)
- The AC adaptor should be connected to a vertically oriented or floor-mounted AC outlet. Do not connect the AC adaptor to a ceiling-mounted AC outlet, as the weight of the adaptor may cause it to become disconnected.

Preparation

Battery installation

- 1 Insert the batteries negative (⊖) terminal first.

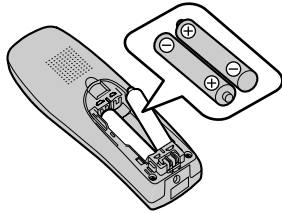

- 2 Close the handset cover.

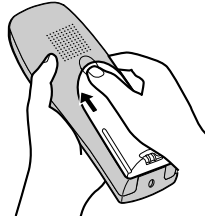

Note:

- Use only rechargeable batteries (page 5).

Battery charge

Place the handset on the base unit for about 7 hours before initial use. When charging,  and battery strength icon are alternately shown on the display.

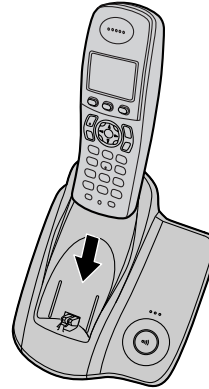

When the batteries are fully charged,  flashes.





Note:

- It takes 7 hours to fully charge the batteries, however, you can use the handset before the batteries are fully charged.
- Clean the charge contacts (page 7) of the handset and base unit with a soft, dry cloth once a month, otherwise the batteries may not charge properly. Clean more often if the unit is exposed to grease, dust or high humidity.

Battery strength

Battery icon	Battery strength
	High
	Medium
	Low When flashing: Needs to be charged.

Note:

- When  flashes, recharge the handset batteries.  will continue to flash until the batteries have been charged for at least 15 minutes.
- If the handset is turned off, it will be turned on automatically when it is placed on the base unit.

Preparation

Battery life

After your Panasonic batteries are fully charged, you can expect the following performance:

Ni-MH batteries (700 mAh)

Operation	Operating time
While in use (talking)	16 hours max.
While not in use (standby)	170 hours max.

Note:

- Actual battery performance depends on a combination of how often the handset is in use (talking) and how often it is not in use (standby).
- Battery operating time may be shortened over time depending on usage conditions and ambient temperature.

Screen saver mode

The backlight will turn off completely after 1 minute of inactivity if the handset is not on the base unit. Only essential icons and the date and time will be displayed, and they will occasionally change position in order to preserve the life of the display.

Example:

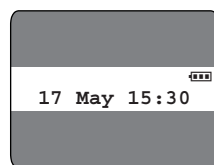

To use the handset when it is in screen saver mode, first press **[*0]** to turn the display on again.

Battery replacement

If  flashes even after the handset batteries have been charged for 7 hours, the batteries must be replaced.

Important:

- Use only the Panasonic rechargeable batteries noted on page 5. If you install non-rechargeable batteries and start charging, the batteries may leak electrolyte.
- Do not mix old and new batteries.

- 1 Press the notch on the handset cover firmly and slide it in the direction of the arrow.

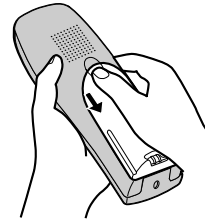

- 2 Remove the old batteries positive (+) terminal first and install the new ones. See page 10 for battery installation.

Turning the power on/off

Power on

Press **[*0]** for about 1 second.

- The display will change to the standby mode.

Power off

Press **[*0]** for about 2 seconds.

- The display will go blank.

Preparation

Setting the date and time

Important:

- Confirm that the AC adaptor is connected.
- Ensure that Ψ is not flashing. If the handset is in screen saver mode, Ψ is not displayed. Press [Ψ \odot] to turn the display on.

- 1 Press \square (middle soft key).
- 2 Select Ψ , then press **OK**.
- 3 Select "Set Date & Time", then press **OK**.
- 4 Enter the current day, month and year by selecting 2 digits for each.
Example: 17 May, 2004
Press [1][7] [0][5] [0][4].
- 5 Enter the current hour and minute by selecting 2 digits for each.
 - You can select "AM", "PM" or 24-hour time entry by pressing [\ast] repeatedly.**Example:** 3:30 PM
Press [0][3] [3][0], then press [\ast] repeatedly until "03:30 PM" is displayed.
- 6 Press **OK**.
- 7 Press [Ψ \odot].

Note:

- To correct a digit, press [\blacktriangleleft] or [\blacktriangleright] to move the cursor, then make the correction.
- The date and time may be incorrect after a power failure. In this case, set the date and time again.

Making/Answering Calls

Making calls

- 1 Lift the handset and dial the phone number.
 - To correct a digit, press **[C/⊗]**, then enter the correct number.
- 2 Press **[↶]**.
- 3 When finished talking, press **[⊗/⊙]** or place the handset on the base unit.

Speakerphone

The handset features a digital speakerphone, which allows you to have hands-free conversations.

- 1 During a conversation, press **[⊗]** to turn on the speakerphone.
 - Speak alternately with the caller.
- 2 When finished talking, press **[⊗/⊙]** or place the handset on the base unit.

Note:

- For best performance, please note the following:
 - Use the speakerphone in a quiet environment.
 - If you or the other party have difficulty hearing each other, press **[▲]** or **[▼]** repeatedly to adjust the speaker volume as necessary.
- To switch back to the receiver, press **[↶]**.

To adjust the receiver or speaker volume

Press **[▲]** or **[▼]** while talking. 4 volume levels are available for the receiver. 6 levels are available for the speaker.

Redial feature

Previously dialled phone numbers (each 24 digits max.) can be redialled.

To redial the last number dialled

Press **[↶]** (right soft key), then press **[↶]** or **[⊗]**.

- If **[⊗]** is pressed, the unit will redial automatically if the other party's line is engaged.

Note:

- You can also press **[↶]** or **[⊗]** before pressing **[↶]**.

To make a call using the redial list

The last 10 phone numbers dialled are stored in the redial list.

- 1 Press **[↶]** (right soft key).
 - The last number dialled will be displayed.
- 2 Press **[▲]** or **[▼]** repeatedly to select the desired number.
 - To exit the list, press **[⊗/⊙]**.
- 3 Press **[↶]** or **[⊗]**.
 - If **[⊗]** is pressed, the unit will redial automatically if the other party's line is engaged.

To redial automatically

If you press **[⊗]** when redialling and the other party's line is engaged, the unit will redial the phone number again automatically. The unit will redial up to 11 times. While the handset is waiting to redial, **[⊗]** will flash. While the handset is redialling, mute is automatically turned on.

Note:

- Automatic redial is cancelled when any button (except **[↶]**) is pressed.
- If mute does not turn off after the line is connected, press **[C/⊗]**.

To edit a number in the redial list before calling it

- 1 Press **[↶]** (right soft key).
- 2 Press **[▲]** or **[▼]** repeatedly to select the desired number, then press **[⊗]**.

Making/Answering Calls

- 3 Select "Edit and Call", then press **OK**.
- 4 Press [**◀**] or [**▶**] to move the cursor, then edit the number.
 - Place the cursor on the number you wish to erase, then press [**C/ⓧ**].
 - Place the cursor to the right of where you want to insert a number, then press the appropriate dial key.
- 5 Press [**↶**], [**↷**], or **OK** to call.

To erase numbers in the redial list

- 1 Press **ⓧ** (right soft key).
- 2 Press [**▲**] or [**▼**] repeatedly to select the desired number, then press **ⓧ**.
- 3 Select "Erase", then press **OK**.
 - If you want to erase all numbers in the list, select "Erase All", then press **OK**.
- 4 Select "yes", then press **OK**.
- 5 Press [**↶**].

To store a number from the redial list into the phonebook

- 1 Press **ⓧ** (right soft key).
- 2 Press [**▲**] or [**▼**] repeatedly to select the desired number, then press **ⓧ**.
- 3 Select "Add Phonebook", then press **OK**.
- 4 Enter a name (16 characters max.; see page 43 for character entry), then press **OK**.
- 5 Edit the phone number if necessary, then press **OK**.
- 6 Select the desired category (page 16), then press **OK** 2 times.
- 7 Press [**↶**].

Other features

Voice enhancer

You can change the tone quality of the receiver while you are on a call. 3 settings are available.

- 1 Press **ⓧ** (middle soft key) during a call.
- 2 Select the desired setting, then press **OK**.

Note:

- If you select "High Tone" or "Low Tone", **ⓧ** is displayed.

Mute

You can mute your voice during a conversation. While mute is turned on, you will be able to hear the other party, but the other party will not be able to hear you.

- 1 To mute your voice, press [**C/ⓧ**].
- 2 To return to the conversation, press [**C/ⓧ**] again.

Key lock

The handset can be locked so that no calls or settings can be made. Incoming calls can be answered, but all other functions are disabled while key lock is on.

To turn key lock on, press **ⓧ** (middle soft key) for about 2 seconds.

- **ⓧ** is displayed.
- To turn key lock off, press **ⓧ** (middle soft key) for about 2 seconds.

Note:

- Calls to emergency numbers (page 27) cannot be made until key lock is turned off.
- Key lock is turned off when the handset is turned off.

Making/Answering Calls

R button (to use the recall feature)

[R] is used to access optional telephone services. Contact your service provider for details.

Note:

- If your unit is connected to a PBX (private branch exchange), pressing **[R]** can allow you to access certain features of your host PBX such as transferring an extension call. Consult your PBX dealer for details.
- You can change the recall time (page 27).

Pause button (for PBX/long distance service users)

A pause is sometimes required when making calls using a PBX or long distance service.

Example: If you have to dial **[0]** before dialling outside numbers manually, you will probably pause after dialling **[0]** until you hear a dial tone.

- 1 Press **[0]**.
- 2 Press **[P]** (right soft key).
- 3 Dial the phone number, then press **[↶]** or **[↷]**.

Note:

- Pressing **[P]** 1 time creates 1 pause. Press **[P]** repeatedly to create longer pauses. To change pause length, see page 27.

Temporary tone dialling (for rotary or pulse service users)

You can temporarily switch the dialling mode to tone when you need to access touch tone services (e.g., telephone banking services).

- 1 Make a call.
- 2 Press **[*]** when prompted to enter your code or PIN, then press the appropriate dial keys.

Note:

- The dialling mode will return to pulse when you hang up.

Answering calls

- 1 Lift the handset and press **[↶]** or **[↷]** when the unit rings.
 - You can also answer a call by pressing any dial key from **[0]** to **[9]**, **[*]**, **[#]**, or **[INT]**. (**Any key answer feature**)
- 2 When finished talking, press **[↶⊙]** or place the handset on the base unit.

Auto talk feature

You can answer calls simply by lifting the handset off the base unit. You do not need to press **[↶]**. To turn this feature on, see page 23.

To adjust the ringer volume when an outside call comes in

Press **[▲]** or **[▼]** when an outside call comes in.

Note:

- The ringer volume cannot be adjusted if the handset is on the base unit.

Other features

Handset locator

Using this feature, you can locate the handset if it has been misplaced.

- 1 Press **[📞]** on the base unit.
 - The base unit will page the handset for about 1 minute.
- 2 To stop paging, press **[📞]** on the base unit or press **[↶⊙]** on the handset.

Phonebook

Using the phonebook

The phonebook allows you to make calls without having to dial manually. You can add 200 names and phone numbers to the phonebook, assign each phonebook entry to the desired category, and search for phonebook entries by name or category.

Adding entries to the phonebook

- 1 Press (left soft key), then press .
- 2 Select "New Entry", then press **OK**.
- 3 Enter the party's name (16 characters max.; see page 43 for character entry), then press **OK**.
- 4 Enter the party's phone number (24 digits max.), then press **OK**.
- 5 Select the desired category for the entry.
- 6 To save the entry, press **OK** 2 times.
- 7 Press .

Note:

- If there is no space to store new entries, "Memory Full" will be displayed. Erase unnecessary entries (page 17).

To edit/correct a mistake

Press or to place the cursor on the number or character you wish to erase, then press . Place the cursor to the right of where you want to insert a number or character, then press the appropriate dial key.

Note:

- Press and hold to erase all numbers or characters.

Categories

Categories can help you find entries in the phonebook quickly and easily. When adding an entry to the phonebook you can assign it to the desired category. You can change the

names of categories assigned for phonebook entries ("Friends", "Family", etc.) and then search for phonebook entries by category. Additional category features are available for Caller ID subscribers (page 30).

Changing category names

- 1 Press (left soft key), then press .
- 2 Select "Category", then press **OK**.
- 3 Select the category you want to change the name of, then press **OK**.
- 4 Select "Category Name", then press **OK**.
- 5 Edit the name (10 characters max.; see page 43 for character entry), then press **OK**.
- 6 Press .

Finding and calling a phonebook entry

Phonebook entries can be searched for by first character, by category, or by scrolling through all phonebook entries. Once you have found the desired entry, press or to dial the phone number.

Scrolling through all entries

- 1 Press (left soft key).
- 2 Press or repeatedly to display the desired entry.

Searching by first character (index search)

- 1 Press (left soft key), then press .
- 2 Select "Index Search", then press **OK**.
- 3 Select the character entry mode that contains the character you are searching for, and press **OK**.

Phonebook

- 4 Press the dial key ([0] to [9]) which contains the character you are searching for (page 43).
 - Press the same dial key repeatedly to display the first entry corresponding to each letter located on that dial key.
 - If there is no entry corresponding to the letter you selected, the next entry will be displayed.
- 5 Press [▲] or [▼] repeatedly to scroll through the phonebook if necessary.

Searching by category

- 1 Press [☰] (left soft key), then press [☰].
- 2 Select "Category Search", then press [OK].
- 3 Select the category you want to search, then press [OK].
 - The first entry in that category is displayed.
 - If you select "All", the unit will end the category search.
- 4 Press [▲] or [▼] repeatedly to scroll through the phonebook if necessary.

Editing entries in the phonebook

Phonebook entries can be edited after you have saved them. You can change the name, phone number, and category.

Changing a name, phone number, category

- 1 Find the desired entry (page 16), then press [☰] (middle soft key).
- 2 Select "Edit", then press [OK].
- 3 Edit the name if necessary (16 characters max.; see page 43 for character entry), then press [OK].
- 4 Edit the phone number if necessary (24 digits max.), then press [OK].

- 5 Select the desired category, then press [OK] 2 times.
- 6 Press [✕].

Erasing entries from the phonebook

Erasing an entry

- 1 Find the desired entry (page 16), then press [☰] (middle soft key).
- 2 Select "Erase", then press [OK].
- 3 Select "Yes", then press [OK].
- 4 Press [✕].

Erasing all entries

- 1 Press [☰] (left soft key), then press [☰].
- 2 Select "Erase All", then press [OK].
- 3 Select "Yes", then press [OK].
- 4 Select "Yes" again, then press [OK].
- 5 Press [✕].

One touch dial

Assigning an entry in the phonebook to a one touch dial key

Dial keys [1] to [9] can each be used as a one touch dial key, allowing you to dial a number from the phonebook by simply pressing a dial key.

- 1 Find the desired entry (page 16), then press [☰] (middle soft key).
- 2 Select "One Touch Dial", then press [OK].
- 3 Press [▲] or [▼] to select the desired dial key number, then press [OK].
 - When the dial key is already used as a one touch dial key, "*" is displayed next to the dial key number. If you select this dial key, "Overwrite" is

Phonebook

displayed. You can overwrite the previous assignment if necessary.

- If you do not wish to overwrite, select "Go Back".

- 4 Press **OK**.
- 5 Press [**↶**].

Making a call using a one touch dial key

- 1 Press and hold the desired one touch dial key ([**1**] to [**9**]).
 - You can view other one touch dial assignments by pressing [**▲**] or [**▼**].
- 2 Press [**↶**] or [**↷**].

Erasing a one touch dial assignment

- 1 Press and hold the desired one touch dial key ([**1**] to [**9**]).
- 2 Press **OK** (middle soft key), then press **OK**.
- 3 Select "Yes", then press **OK**.

Note:

- Only the one touch dial assignment is erased. The corresponding phonebook entry is not erased.

Chain dial

This feature allows you to dial phone numbers in the phonebook while you are on a call. This feature can be used, for example, to dial a calling card access number or bank account PIN that you have stored in the phonebook, without having to dial manually.

- 1 While on a call, press **OK** (left soft key).
- 2 Press [**▲**] or [**▼**] repeatedly to select the desired entry.
 - To search by first character (index search), see page 16. To search by category, see page 17.
- 3 Press **OK** to dial the number.

Copying phonebook entries to other handsets

Phonebook entries (page 16) can be copied from the handset to the phonebook of a compatible Panasonic handset.

Copying one entry

- 1 Find the desired entry (page 16), then press **OK** (middle soft key).
- 2 Select "Copy", then press **OK**.
- 3 Enter the handset number you wish to send the phonebook entry to.
- 4 To continue copying another entry, select "Yes", then press **OK**. Find the desired entry, then press **OK**.
 - To finish copying, select "No", then press **OK**.
- 5 Press [**↶**].

Copying all entries

- 1 Press **OK** (left soft key), then press **OK**.
- 2 Select "Copy All", then press **OK**.
- 3 Enter the handset number you wish to send the phonebook entries to.
 - When all entries have been copied, "Completed" is displayed.
- 4 Press [**↶**].

Note:

- If the other handset (the receiver) is not in standby mode, "Failed" is displayed on your handset (the sender).
- If copying failed after copying at least 1 entry, "Incomplete" is displayed on your handset (the sender).

Handset Settings

Guide to handset settings

For your reference, a chart of all items which can be customised for the handset is printed below.

- When customising the handset, the current item or setting is highlighted.

Handset settings menu	Sub-menu	Sub-menu 2	Default setting	Page	
Time Settings	Set Date & Time		—	page 12	
	Alarm		Off	page 20	
Ringer Setup	Ringer Volume		Maximum	page 20	
	Ext. Ringtone		Ringtone 1	page 20	
	Int. Ringtone		Ringtone 1	page 20	
	Night Mode	Start/End		23:00/06:00	page 21
		On/Off		Off	page 21
		Ring Delay		60 sec.	page 21
Select Category		—	page 22		
Display Setup	Wallpaper		Wallpaper1	page 22	
	Display Colour		Colour1	page 22	
	Standby Display		Off	page 22	
	Select Language		English	page 23	
	Contrast		Contrast 3	page 23	
Call Options	Call Bar		Off	page 23	
	Auto Talk		Off	page 23	
Registration	Register H.set		—	page 38	
Select Base	—		Auto	page 39	
Other Options	Handset PIN		0000	page 23	
	LetterWise		English	page 24	
	Keytones		On	page 24	
	Reset Handset		—	page 24	

Note:





- Up to 3 menu items can be displayed at a time. To select a menu item not shown on the current page, scroll up or down by pressing the navigator key, [▲] or [▼], respectively.

Handset Settings

Time settings

Alarm

An alarm will sound for 3 minutes at the set time once or daily. Set the date and time beforehand (page 12).





- 1 Press  (middle soft key).
- 2 Select , then press **OK**.
- 3 Select "Alarm", then press **OK** 2 times.
- 4 Select an alarm mode, then press **OK**.
 - "Once": The alarm will sound once at the set time. Enter the desired day and month by selecting 2 digits for each.
 - "Daily": An alarm will sound daily at the set time.
 - "Off": Turns the alarm off. Press **OK** again, then press .
- 5 Enter the desired hour and minute by selecting 2 digits for each.
 - You can select "AM", "PM" or 24-hour time entry by pressing  repeatedly.
- 6 Press **OK**.
- 7 Select the ringtone that will sound at the set time, then press **OK** 2 times.
- 8 Press .

Note:

- When the alarm is set,  is displayed.
- To stop the alarm, press any dial key.
- When in talk or intercom mode, the alarm will not sound until the call has ended.
- The alarm will sound at the set time even when the ringer volume is turned off.
- If you select "Once", the setting will change to "Off" after the alarm sounds.

Ringer setup

Ringer volume

- 1 Press  (middle soft key).
- 2 Select , then press **OK**.
- 3 Select "Ringer Setup", then press **OK**.
- 4 Select "Ringer Volume", then press **OK**.
- 5 Press  or  repeatedly to select the desired volume.
- 6 Press **OK**.
- 7 Press .

Note:



- When the ringer volume is turned off,  is displayed.
- Alarms will sound and the handset will ring for intercom calls and when paged even if the ringer is turned off.

Changing ringtones

You can change the ringtone used by the handset.

"Ext. Ringtone": Selects the ringtone for outside calls.

"Int. Ringtone": Selects the ringtone for intercom calls.

- 1 Press  (middle soft key).
- 2 Select , then press **OK**.
- 3 Select "Ringer Setup", then press **OK**.
- 4 Select the desired item, then press **OK**.
- 5 Select the desired ringtone, then press **OK**.
- 6 Press .

Note:

- If you select one of the melody ringtones, the ringtone will continue to sound for

Handset Settings

several seconds if the caller hangs up before you answer. You may hear a dial tone or no one on the line when you answer a call.

- The preset melodies in this product are used with permission of © 2004 M-ZoNE Co., Ltd.

Night mode

Night mode allows you to select a block of time during which the handset will not ring for outside calls. This feature is useful for times when you do not want to be disturbed, for example, while sleeping. Night mode can be set independently for the handset and the base unit (page 26).

Using the phonebook's category feature (page 16), you can also select categories of callers whose calls will override night mode and ring the handset (Caller ID subscribers only).

Set the date and time beforehand (page 12).

Setting the start and end time for night mode

- 1 Press **[M]** (middle soft key).
- 2 Select **[P]**, then press **[OK]**.
- 3 Select "Ringer Setup", then press **[OK]**.
- 4 Select "Night Mode", then press **[OK]**.
- 5 Select "Start/End", then press **[OK]**.
- 6 Enter the desired hour and minute you wish to start this feature by selecting 2 digits for each.
 - If you use 12-hour time entry, select "AM" or "PM" by pressing **[*]** repeatedly before entering the time.
- 7 Enter the desired hour and minute you wish to end this feature by selecting 2 digits for each.

- If you use 12-hour time entry, select "AM" or "PM" by pressing **[*]** repeatedly before entering the time.

8 Press **[OK]**.

9 Press **[*0]**.

Turning night mode on/off

- 1 Press **[M]** (middle soft key).
- 2 Select **[P]**, then press **[OK]**.
- 3 Select "Ringer Setup", then press **[OK]**.
- 4 Select "Night Mode", then press **[OK]**.
- 5 Select "On/Off", then press **[OK]**.
- 6 Select "on" or "off", then press **[OK]**.
- 7 Press **[*0]**.

Note:

- When the night mode is turned on, **[M]** is displayed.



Setting the ring delay for night mode

This setting allows the handset to ring during night mode if the caller waits long enough. After the selected amount of time passes, the handset will ring, useful when someone urgently needs to speak with you. If you select "No Ringing", the handset will not ring during night mode.

- 1 Press **[M]** (middle soft key).
- 2 Select **[P]**, then press **[OK]**.
- 3 Select "Ringer Setup", then press **[OK]**.
- 4 Select "Night Mode", then press **[OK]**.
- 5 Select "Ring Delay", then press **[OK]**.
- 6 Select the desired setting, then press **[OK]**.
- 7 Press **[*0]**.

Handset Settings

Selecting categories to bypass night mode

- 1 Press  (middle soft key).
- 2 Select , then press **OK**.
- 3 Select "Ringer Setup", then press **OK**.
- 4 Select "Night Mode", then press **OK**.
- 5 Select "Select Category", then press **OK**.
- 6 Press the desired category numbers, then press **OK**.
 - The selected category number will flash.
 - To cancel a selected category number, press the number again. The number will stop flashing.
- 7 Press [].





Note:

- If a call is received from one of the categories set to bypass night mode, only the handset will ring.

Display setup

Selecting wallpaper

You can select the "wallpaper" shown on the display in standby mode from one of the preset patterns.



- 1 Press  (middle soft key).
- 2 Select , then press **OK**.
- 3 Select "Display Setup", then press **OK**.
- 4 Select "Wallpaper", then press **OK**.
 - The current wallpaper is displayed.
- 5 Press [] or [] repeatedly to select the desired item, then press **OK**.
- 6 Press [].

Note:

- If you select "Off", the display colour will be changed to the colour you selected for display colour (page 22).

Selecting a display colour

You can select the desired display colour.



- 1 Press  (middle soft key).
- 2 Select , then press **OK**.
- 3 Select "Display Setup", then press **OK**.
- 4 Select "Display Colour", then press **OK**.
- 5 Select the desired colour, then press **OK**.
- 6 Press [].

Selecting the standby mode display

"Base Number": The current base unit number is displayed.

"Handset Number": The current handset number is displayed.

"Off": Only the current date and time are displayed.

- 1 Press  (middle soft key).
- 2 Select , then press **OK**.
- 3 Select "Display Setup", then press **OK**.
- 4 Select "Standby Display", then press **OK**.
- 5 Select the desired setting, then press **OK**.
- 6 Press [].

Note:

- If "Base Number" is selected and the current base unit number is 2, "-2-" is displayed.
- If "Handset Number" is selected and the current handset number is 2, "[2]" is displayed.

Handset Settings

Changing the display language

- 1 Press **[OK]** (middle soft key).
- 2 Select **[OK]**, then press **[OK]**.
- 3 Select "Display Setup", then press **[OK]**.
- 4 Select "Select Language", then press **[OK]**.
- 5 Select the desired language, then press **[OK]**.
- 6 Press **[OK]**.

Note:

- If you select a language you cannot read, press **[OK]**, **[OK]**, press **[OK]**, press **[OK]** 2 times, press **[OK]**, press **[OK]** 3 times, press **[OK]**, select the desired language, then press **[OK]**. Press **[OK]**.

Changing the display contrast

This feature is available for wallpaper and display icons.

- 1 Press **[OK]** (middle soft key).
- 2 Select **[OK]**, then press **[OK]**.
- 3 Select "Display Setup", then press **[OK]**.
- 4 Select "Contrast", then press **[OK]**.
- 5 Press **[OK]** or **[OK]** repeatedly to select the desired contrast, then press **[OK]**.
- 6 Press **[OK]**.

Call options

Turning call bar on/off

This feature prohibits making outside calls. When call bar is turned on, only intercom calls and calls to emergency numbers (page 27) can be made.

- 1 Press **[OK]** (middle soft key).

- 2 Select **[OK]**, then press **[OK]**.
- 3 Select "Call Options", then press **[OK]**.
- 4 Select "Call Bar", then press **[OK]**.
- 5 Enter "0000" (default handset PIN).
 - If you changed the PIN, enter it (page 23).
- 6 Select "On" or "Off", then press **[OK]**.
- 7 Press **[OK]**.

Note:

- When call bar is turned on, **[OK]** is displayed.

Turning auto talk on/off

When this feature is turned on, you can answer calls simply by lifting the handset off the base unit. You do not need to press **[OK]**.

- 1 Press **[OK]** (middle soft key).
- 2 Select **[OK]**, then press **[OK]**.
- 3 Select "Call Options", then press **[OK]**.
- 4 Select "Auto Talk", then press **[OK]**.
- 5 Select "On" or "Off", then press **[OK]**.
- 6 Press **[OK]**.

Other options



Changing the handset PIN (Personal Identification Number)

For security, the handset PIN must be entered when changing certain settings. The default PIN is "0000".

Important:



- If you change the PIN, please make note of your new PIN. The unit will not reveal the PIN to you. If you forget your PIN, consult your nearest Panasonic service centre.

Handset Settings

- 1 Press  (middle soft key).
- 2 Select , then press **OK**.
- 3 Select "Other Options", then press **OK**.
- 4 Select "Handset PIN", then press **OK**.
- 5 Enter the current 4-digit handset PIN.
- 6 Enter the new 4-digit handset PIN, then press **OK**.
- 7 Press [].



Changing the LetterWise® language

You can change which language is used for LetterWise character entry (page 36, 43).

- 1 Press  (middle soft key).
- 2 Select , then press **OK**.
- 3 Select "Other Options", then press **OK**.
- 4 Select "LetterWise", then press **OK**.
- 5 Select the desired language, then press **OK**.
- 6 Press [].

Turning keytones on/off



Keytones are tones heard when keys are pressed. Includes confirmation tones and error tones.

- 1 Press  (middle soft key).
- 2 Select , then press **OK**.
- 3 Select "Other Options", then press **OK**.
- 4 Select "Keytones", then press **OK**.
- 5 Select "on" or "off", then press **OK**.
- 6 Press [].

Note:

- If keytones are turned off, error tones will not sound when you enter the wrong PIN or when memory is full.

Resetting the handset to its default settings

- 1 Press  (middle soft key).
- 2 Select , then press **OK**.
- 3 Select "Other Options", then press **OK**.
- 4 Select "Reset Handset", then press **OK**.
- 5 Enter "0000" (default handset PIN).
 - If you changed the PIN, enter it (page 23).
- 6 Select "Yes", then press **OK**.
- 7 Press [].

Note:

- The following items will be deleted or reset to their default settings:
 - Settings listed on page 19
 - Redial list
 - Voice enhancer
 - Category names
 - Category ringtones
 - Category display colours
- The following items will be retained:
 - Phonebook entries (category names, ringtones, and display colours will be reset to their default settings.)
 - Date and time

Base Unit Settings

Guide to base unit settings

For your reference, a chart of all items which can be customised for the base unit is printed below.

- When customising the base unit, the current item or setting is highlighted.

Base unit settings menu	Sub-menu	Sub-menu 2	Default setting	Page
Ringer Setup	Ringer Volume		<i>Medium</i>	page 26
	Night Mode	Start/End	23:00/06:00	page 26
		On/Off	Off	page 26
		Ring Delay	60 sec.	page 26
Call Options	Dial Mode		Tone	page 27
	Recall		600 msec.	page 27
	Pause Length		3 sec.	page 27
	Emergency No.		—	page 27
	Call Restrict		—	page 28
Other Options	Base Unit PIN		0000	page 28
	Repeater Mode		Off	page 40
	Reset Base		—	page 28





Note:

- Up to 3 menu items can be displayed at a time. To select a menu item not shown on the current page, scroll up or down by pressing the navigator key, [▲] or [▼], respectively.

Base Unit Settings

Ringer setup



Ringer volume

- 1 Press  (middle soft key).
- 2 Select , then press **OK**.
- 3 Enter "0000" (default base unit PIN).
 - If you changed the PIN, enter it (page 28).
- 4 Select "Ringer Setup", then press **OK**.
- 5 Select "Ringer Volume", then press **OK**.
- 6 Press [] or [] repeatedly to select the desired volume.
- 7 Press **OK**.
- 8 Press [].

Night mode

Night mode allows you to select a block of time during which the base unit will not ring for outside calls. This feature is useful for times when you do not want to be disturbed, for example, while sleeping. Night mode can be set independently for the handset (page 21) and the base unit. Set the date and time beforehand (page 12).

Setting the start and end time for night mode

- 1 Press  (middle soft key).
- 2 Select , then press **OK**.
- 3 Enter "0000" (default base unit PIN).
 - If you changed the PIN, enter it (page 28).
- 4 Select "Ringer Setup", then press **OK**.
- 5 Select "Night Mode", then press **OK**.
- 6 Select "Start/End", then press **OK**.

- 7 Enter the desired hour and minute you wish to start this feature by selecting 2 digits for each.

- If you use 12-hour time entry, select "AM" or "PM" by pressing [] repeatedly before entering the time.



- 8 Enter the desired hour and minute you wish to end this feature by selecting 2 digits for each.

- If you use 12-hour time entry, select "AM" or "PM" by pressing [] repeatedly before entering the time.

- 9 Press **OK**.



- 10 Press [].

Turning night mode on/off

- 1 Press  (middle soft key).
- 2 Select , then press **OK**.
- 3 Enter "0000" (default base unit PIN).
 - If you changed the PIN, enter it (page 28).
- 4 Select "Ringer Setup", then press **OK**.
- 5 Select "Night Mode", then press **OK**.
- 6 Select "On/Off", then press **OK**.
- 7 Select "On" or "Off", then press **OK**.
- 8 Press [].

Setting the ring delay for night mode

This setting allows the base unit to ring during night mode if the caller waits long enough. After the selected amount of time passes, the base unit will ring, useful when someone urgently needs to speak with you. If you select "No Ringing", the base unit will not ring during night mode.

- 1 Press  (middle soft key).
- 2 Select , then press **OK**.
- 3 Enter "0000" (default base unit PIN).
 - If you changed the PIN, enter it (page 28).

Base Unit Settings

- 4 Select "Ringer Setup", then press **OK**.
- 5 Select "Night Mode", then press **OK**.
- 6 Select "Ring Delay", then press **OK**.
- 7 Select the desired setting, then press **OK**.
- 8 Press [**ⓧ**].

Call options

Setting dialling mode (tone/pulse)

"Tone": Select when you have a touch tone service.

"Pulse": Select when you have rotary or pulse service.

- 1 Press **☐** (middle soft key).
- 2 Select **/**, then press **OK**.
- 3 Enter "0000" (default base unit PIN).
 - If you changed the PIN, enter it (page 28).
- 4 Select "Call Options", then press **OK** 2 times.
- 5 Select the desired setting, then press **OK**.
- 6 Press [**ⓧ**].

Changing the recall time

Change the recall time, if necessary, depending on the requirements of your service provider or PBX.

- 1 Press **☐** (middle soft key).
- 2 Select **/**, then press **OK**.
- 3 Enter "0000" (default base unit PIN).
 - If you changed the PIN, enter it (page 28).

- 4 Select "Call Options", then press **OK**.
- 5 Select "Recall", then press **OK**.
- 6 Select the desired setting, then press **OK**.
- 7 Press [**ⓧ**].

Setting pause length

Change the pause length, if necessary, depending on the requirements of your service provider or PBX.

- 1 Press **☐** (middle soft key).
- 2 Select **/**, then press **OK**.
- 3 Enter "0000" (default base unit PIN).
 - If you changed the PIN, enter it (page 28).
- 4 Select "Call Options", then press **OK**.
- 5 Select "Pause Length", then press **OK**.
- 6 Select the desired setting, then press **OK**.
- 7 Press [**ⓧ**].

Storing/changing emergency numbers

These settings determine which phone numbers can be dialled while the call bar feature is on (page 23).

- 1 Press **☐** (middle soft key).
- 2 Select **/**, then press **OK**.
- 3 Enter "0000" (default base unit PIN).
 - If you changed the PIN, enter it (page 28).
- 4 Select "Call Options", then press **OK**.
- 5 Select "Emergency No.", then press **OK**.
- 6 Select a memory location, then press **OK**.

Base Unit Settings

- If the memory location already contains an emergency number, the number is displayed.
- 7 Enter/edit the number, then press **OK**.
 - To erase an emergency number, press and hold **[C/⊗]**.
 - 8 Press **[↶⊙]**.

Setting call restriction

You can restrict selected handsets from dialling certain numbers. You can assign up to 6 phone numbers to be restricted, and select which handsets will be restricted. Storing area codes here will prevent the restricted handsets from dialling any phone number in that area code. If a restricted number is dialled, the call will not be connected and the restricted number will flash on the display.

- 1 Press **[⊞]** (middle soft key).
- 2 Select **[↵]**, then press **OK**.
- 3 Enter "0000" (default base unit PIN).
 - If you changed the PIN, enter it (page 28).
- 4 Select "Call Options", then press **OK**.
- 5 Select "Call Restrict", then press **OK**.
- 6 Set which handsets will be restricted by pressing the desired handset number.
 - All the registered handset numbers will be displayed.
 - Flashing numbers indicate call restriction is turned on for the corresponding handset.
 - To turn call restriction off for a handset, press the number again. The number will stop flashing.
- 7 Press **OK**.
- 8 Select a memory location, then press **OK**.

- If the memory location already contains a restricted number, the number is displayed.
- 9 Enter the phone number or area code to be restricted (8 digits max.), then press **OK**.
 - To erase a restricted number, press **[C/⊗]**.
 - 10 Press **[↶⊙]**.

Other options

Changing the base unit PIN (Personal Identification Number)

For security, the base unit PIN must be entered when changing certain settings. The default PIN is "0000".

Important:

- If you change the PIN, please make note of your new PIN. The unit will not reveal the PIN to you. If you forget your PIN, consult your nearest Panasonic service centre.

- 1 Press **[⊞]** (middle soft key).
- 2 Select **[↵]**, then press **OK**.
- 3 Enter "0000" (default base unit PIN).
 - If you changed the PIN, enter it.
- 4 Select "Other Options", then press **OK**.
- 5 Select "Base Unit PIN", then press **OK**.
- 6 Enter the new 4-digit base unit PIN, then press **OK**.
- 7 Press **[↶⊙]**.

Resetting the base unit to its default settings

- 1 Press **[⊞]** (middle soft key).
- 2 Select **[↵]**, then press **OK**.

Base Unit Settings

- 3** Enter "0000" (default base unit PIN).
 - If you changed the PIN, enter it (page 28).
- 4** Select "Other Options", then press **OK**.
- 5** Select "Reset Base", then press **OK**.
- 6** Select "Yes", then press **OK**.
- 7** Press [**7**0].

Note:

- The following items will be deleted or reset to their default settings:
 - Settings listed on page 25, 35
 - All SMS messages
 - Caller list
- The following items will be retained:
 - Date and time
 - Repeater mode

Caller ID Service

Using Caller ID service

Important:



- This unit is Caller ID compatible. To use Caller ID features (such as displaying caller phone numbers), you must subscribe to Caller ID service. Consult your service provider for details.

Caller ID features

When an outside call is received, the caller's phone number can be displayed.

- Phone numbers of the last 50 different callers will be logged in the caller list.
- When caller information is received and it matches a phone number stored in the unit's phonebook:
 - The stored name will be displayed and logged in the caller list.
 - The handset will use the display colour and ringtone assigned to the caller's category.
- If the unit is connected to a PBX system, you may not receive the caller information.
- When the caller dialed from an area which does not provide Caller ID service, "Out of Area" will be displayed.
- When the caller requested not to send caller information, either no information or "Private Caller" will be displayed.

Missed calls

If a call is not answered, the unit treats the call as a missed call.  is shown on the display. When the screen saver mode (page 11) is cancelled, the number of missed calls is displayed next to . This lets you know if you should view the caller list to see who called while you were out.



Category features for Caller ID subscribers

Categories can help you identify who is calling by using different ringtones and

display colours for different categories of callers. When adding an entry to the phonebook you can assign it to the desired category (page 16). When a call is received from a caller assigned to a category, the category's display colour and ringtone you select is used.



Changing category ringtones

You can select a ringtone for each category. If you select "Ext. Ringtone", the unit will use the external ringtone you set on page 20 when calls from this category are received. The default setting is "Ext. Ringtone".

- 1 Press , then press .
- 2 Select "Category", then press **OK**.
- 3 Select a category, then press **OK**.
- 4 Select the current setting of the category ringtone, then press **OK**.
- 5 Select the desired ringtone, then press **OK**.
- 6 Press [].

Changing category display colours

You can select a display colour for each category. If you select "Display Colour", the unit will use the display colour you set on page 22 when calls from this category are received. The default setting is "Display Colour".

- 1 Press , then press .
- 2 Select "Category", then press **OK**.
- 3 Select a category, then press **OK**.
- 4 Select the current setting of the category colour, then press **OK**.
- 5 Select the desired colour, then press **OK**.
- 6 Press [].

Caller ID Service

Caller list

Viewing the caller list and calling back

Phone numbers of the last 50 different callers will be logged in the caller list. When the 51st call is received, the oldest caller information will be automatically erased. You can use this list to return missed calls.

- 1 Press **[M]** (middle soft key).
- 2 Select **→)**, then press **OK**.
 - The most recent call is displayed.
- 3 Press **[▼]** repeatedly to search from the most recent call, or press **[▲]** repeatedly to search from the oldest call.
 - If the item has already been viewed or answered, **✓** is displayed, even if it was viewed or answered using another handset.
 - To erase the item, press **[X]**, select **"Yes"**, then press **OK**.
- 4 Press **[↶]** or **[↷]** to call back the displayed party.

Editing a caller's phone number before calling back

- 1 Press **[M]** (middle soft key).
 - 2 Select **→)**, then press **OK**.
 - 3 Press **[▲]** or **[▼]** repeatedly to display the desired entry.
 - 4 **To add a number**
Press the dial key (**[0]** to **[9]**).
 - The number you pressed is added to the top of the current number.
- To erase a number**
Press **[M]**, select **"Edit and Call"**, then press **OK**.
Press **[◀]** or **[▶]** to place the cursor on the number you wish to erase, then press **[C/⊗]**.

- 5 Press **[↶]**, **[↷]**, or **OK** to call.

Erasing caller information

- 1 Press **[M]** (middle soft key).
- 2 Select **→)**, then press **OK**.
- 3 Press **[▲]** or **[▼]** repeatedly to display the desired entry, then press **[M]**.
- 4 Select **"Erase"**, then press **OK**.
 - To erase all entries, select **"Erase All"**, then press **OK**.
- 5 Select **"Yes"**, then press **OK**.
- 6 Press **[↶]**.

Storing caller information into the phonebook

- 1 Press **[M]** (middle soft key).
- 2 Select **→)**, then press **OK**.
- 3 Press **[▲]** or **[▼]** repeatedly to display the desired entry, then press **[M]**.
- 4 Select **"Add Phonebook"**, then press **OK**.
- 5 Continue from step 3, "Adding entries to the phonebook", page 16.

SMS (Short Message Service)

Using SMS (Short Message Service)

SMS allows you to send and receive text messages between other fixed-line and mobile phones that support compatible SMS networks and features.

Important:



- To use SMS features, you must:
 - subscribe to the Caller ID and/or appropriate service
 - confirm SMS is turned on
 - confirm the correct message centre numbers are stored
- Consult your service provider for details and availability.

Note:

- A total of 47 messages (at 160 characters/message) can be saved. Total number may be more than 47 if length of messages are less than 160 characters/message.
- If the unit is connected to a PBX system, you may not be able to use SMS features.

Turning SMS on/off

The default setting is "Off".



- 1 Press  (middle soft key).
- 2 Select , then press **OK**.
- 3 Select "Settings", then press **OK**.
- 4 Enter "0000" (default base unit PIN).
 - If you changed the PIN, enter it (page 28).
- 5 Select "SMS On/Off", then press **OK**.
- 6 Select "On" or "Off", then press **OK**.
- 7 Press .

Note:

- If you try to send a message while SMS is turned off, a tone sounds and the message is placed in the receive list with "FD" attached to it.
- If someone tries to send you a message while SMS is turned off, the message will not be received and the message centre number will be logged in the caller list.

Storing SMS message centre numbers

SMS message centre telephone numbers must be stored in order to send and receive SMS messages.

- Consult your service provider for more information.
- 1 Press  (middle soft key).
 - 2 Select , then press **OK**.
 - 3 Select "Settings", then press **OK**.
 - 4 Enter "0000" (default base unit PIN).
 - If you changed the PIN, enter it (page 28).
 - 5 Select "Message Centre1" or "Message Centre2", then press **OK**.
 - 6 Edit the number as necessary, then press **OK** 2 times.
 - 7 Press .

Note:

- If your phone is connected to a PBX, you need to add the PBX line access number and a dialling pause to the beginning of the Message Centre 1 phone number.

SMS (Short Message Service)

Sending a message

Writing and sending a new message

- 1 Press **[M]** (middle soft key).
- 2 Select **[M]**, then press **[OK]**.
- 3 Select "Create", then press **[OK]**.
 - If "▲Use Last Text?" is displayed, you can use the text from the last message you created by pressing **[▲]**.
- 4 Enter the message (page 36), then press **[OK]**.
- 5 Enter the destination phone number (20 digits max.), then press **[OK]**.
 - To send the message to a party saved in the phonebook, press **[M]**, select the phonebook entry, then press **[OK]** 2 times.
 - To send the message to a party logged in the caller list, press **[▲]** or **[▼]** repeatedly to select the party, then press **[OK]** 2 times.
 - To send the message to a phone number logged in the redial list, press **[C]** repeatedly to select the phone number, then press **[OK]** 2 times.
- 6 To save the message, select "Yes", then press **[OK]**.
 - To send the message without saving it, select "No", then press **[OK]**.
- 7 To send the message, select "Send", then press **[OK]**.
 - To cancel sending, press **[X]**.

Note:

- This unit supports SMS messages of up to 612 characters, however, the maximum number of characters you can send or receive may be limited by your SMS service provider. Consult your SMS service provider for details.

- If your message contains over 160 characters, the message is a long message and **[M]** is displayed. Your service provider may treat long messages differently from other messages. Consult your service provider for details.
- "Invalid Number" is displayed if you try to send a message to a phone number saved in the phonebook, caller list, or redial list that is over 20 digits long.
- When sending a message, "Sending Message" is displayed momentarily, then "Transferring Message" is displayed.
- If your phone is connected to a PBX, store the PBX line access number (page 35).

Sending a saved message

- 1 Press **[M]** (middle soft key).
- 2 Select **[M]**, then press **[OK]**.
- 3 Select "Send List", then press **[OK]**.
- 4 To read a saved message, press **[▲]** or **[▼]** repeatedly to select the message, then press **[OK]**.
 - Messages are displayed in chronological order and by destination phone number.
- 5 To send the message, press **[M]**, select "Send", then press **[OK]**.
- 6 Press and hold **[C/X]** to erase all numbers, then continue from step 5, "Writing and sending a new message", page 33.

Editing and sending a saved message

- 1 Press **[M]** (middle soft key).
- 2 Select **[M]**, then press **[OK]**.
- 3 Select "Send List", then press **[OK]**.
- 4 Press **[▲]** or **[▼]** repeatedly to select the message, then press **[OK]**.

SMS (Short Message Service)

- 5 Press **[M]**, select "Edit Message", press **[OK]**, then continue from step 4, "Writing and sending a new message", page 33.

Erasing saved messages

- 1 Press **[M]** (middle soft key).
- 2 Select **[M]**, then press **[OK]**.
- 3 Select "Send List", then press **[OK]**.
- 4 Press **[▲]** or **[▼]** repeatedly to select the message, then press **[OK]**.
- 5 Press **[M]**, select "Erase", then press **[OK]**.
 - To erase all messages, select "Erase All", then press **[OK]**.
- 6 Select "Yes", then press **[OK]**.
- 7 Press **[*0]**.

Receiving a message

When an SMS message is received:

- a tone is heard (if the ringer is turned off, this tone is not heard)
- "Receiving SMS Message" is displayed
- **[M]** is displayed
- the total number of new (unread) SMS messages is displayed next to **[M]** if the screen saver (page 11) is turned off

Reading a received message

- 1 Press **[M]** (middle soft key).
- 2 Select **[M]**, then press **[OK]**.
- 3 Select "Receive List", then press **[OK]**.
- 4 Press **[▲]** or **[▼]** repeatedly to select a message.
 - Messages which have already been read are indicated by a **✓**, even if they were read using another handset.

- To erase a message, press **[X]**, select "Yes", then press **[OK]**.

- 5 Press **[OK]** to read the message content.

Note:

- To call the message sender, press **[↶]** or **[↷]**.
- If "SMS Full" is displayed, new SMS messages cannot be received. Erase unnecessary messages (page 34).
- If you receive a message from a party saved in the phonebook, the stored name is displayed.
- Some SMS service providers attach a 1-digit number to the message sender's phone number, and sender names stored in the phonebook may not be displayed as a result.

Replying to a message

- 1 While reading a received message, press **[M]** (middle soft key).
- 2 Select "Reply", then press **[OK]**.
- 3 Enter a message (page 36), then press **[OK]**.
- 4 Edit the destination phone number and/or press **[OK]**.
- 5 Continue from step 6, "Writing and sending a new message", page 33.

Editing/forwarding a message

- 1 While reading a received message, press **[M]** (middle soft key).
- 2 Select "Edit Message", then press **[OK]**.
- 3 Continue from step 4, "Writing and sending a new message", page 33.

Erasing received messages

- 1 While reading a received message, press **[M]** (middle soft key).

SMS (Short Message Service)

- 2 Select **"Erase"**, then press **OK**.
 - To erase all messages, select **"Erase All"**, then press **OK**.
- 3 Select **"Yes"**, then press **OK**.
- 4 Press **[↶⊙]**.

Storing the sender's number in the phonebook

- 1 While reading a received message, press **[⊞]** (middle soft key).
- 2 Select **"Add Phonebook"**, then press **OK**.
- 3 Continue from step 3, "Adding entries to the phonebook", page 16.

Editing the sender's number before calling back

- 1 While reading a received message, press **[⊞]** (middle soft key).
- 2 Select **"Edit and Call"**, then press **OK**.
- 3 Edit the number, then press **[↶]**, **[↷]**, or **OK** to call.

Guide to SMS settings

If the base unit is reset to its default settings (page 28), the following SMS-related settings will be reset.

SMS settings	Default setting	Page
SMS on/off	Off	page 32
Message Centre 1	—	page 32
Message Centre 2	—	page 32
PBX line access number	Off	page 35

Note:

- If the base unit is reset to its default settings, the contents of the receive and send lists will be erased.

Storing the PBX line access number (for PBX users only)

Store your PBX line access number (4 digits max.) so that SMS messages are sent properly. When sending SMS messages to entries in the phonebook or redial list, the PBX line access number will be deleted.

- 1 Press **[⊞]** (middle soft key).
- 2 Select **[☑]**, then press **OK**.
- 3 Select **"Settings"**, then press **OK**.
- 4 Enter "0000" (default base unit PIN).
 - If you changed the PIN, enter it (page 28).
- 5 Select **"PBX Access No."**, then press **OK**.
- 6 Select **"On"**, then press **OK**.
- 7 Enter your PBX line access code and a dialling pause, if necessary, then press **OK** 2 times.
- 8 Press **[↶⊙]**.

SMS (Short Message Service)

Available character entries for SMS

Important:

- For character entry when entering the name for phonebook, etc., see page 43.

The dial keys are used to enter characters and numbers. Each dial key has multiple characters assigned to it. The available character entry modes are, LetterWise, Alphabet, Numeric, Greek, and Extended. When in Alphabet (ABC), Greek (ABΓ), or Extended (AÄÅ) character entry modes, you can select which character is entered by pressing a dial key repeatedly.

- Press [◀] or [▶] to move the cursor.
- Press dial keys to enter characters and numbers.
- Press [C/ⓧ] to erase the character or number highlighted by the cursor. Press and hold [C/ⓧ] to erase all characters or numbers.
- Press [*] to switch between uppercase and lowercase.
- To enter another character located on the same dial key, press [▶] to move the cursor to the next space, then press the appropriate dial key. (This is not necessary when entering text in LetterWise mode.)

Character entry modes

Several character entry modes are available. Press **1/A/?** (right soft key), then select a character entry mode, and press **OK**. The default setting is Alphabet.

LetterWise character table (for English)

LetterWise is a simplified text entry system which suggests the most likely letter to follow the previously entered text. Text can be input faster because the number of key presses are reduced. You can change which language is used for LetterWise character entry (page 24).

- Each time you press a dial key, LetterWise will suggest a character. If the suggested character is incorrect, press **#** repeatedly to display the desired character.

0	1	ABC 2	DEF 3	GHI 4	JKL 5	MNO 6	PQRS 7	TUV 8	WXYZ 9
Space 0	Space . @ / : ; * # + - 1 " ' , ! ; ? ¿ _ € £ \$ ¥ () [] { } & % \ ^ ~ < > = α §	A B C 2	D E F 3	G H I 4	J K L 5	M N O 6	P Q R S 7	T U V 8	W X Y Z 9
		a b c 2	d e f 3	g h i 4	j k l 5	m n o 6	p q r s 7	t u v 8	w x y z 9

SMS (Short Message Service)

Alphabet character table (ABC)

0	1	ABC 2	DEF 3	GHI 4	JKL 5	MNO 6	PQRS 7	TUV 8	WXYZ 9
Space 0	Space . @ / : ; * # + - 1 " ' , ! i ? ¿ _ € £ \$ ¥ () [] { } & % \ ^ ~ < > = □ §	A B C 2	D E F 3	G H I 4	J K L 5	M N O 6	P Q R S 7	T U V 8	W X Y Z 9
		a b c 2	d e f 3	g h i 4	j k l 5	m n o 6	p q r s 7	t u v 8	w x y z 9

Numeric entry table (0-9)

0	1	ABC 2	DEF 3	GHI 4	JKL 5	MNO 6	PQRS 7	TUV 8	WXYZ 9
0	1	2	3	4	5	6	7	8	9

Greek character table (ΑΒΓ)

0	1	ABC 2	DEF 3	GHI 4	JKL 5	MNO 6	PQRS 7	TUV 8	WXYZ 9
Space 0	Space . @ / : ; * # + - 1 " ' , ! i ? ¿ _ € £ \$ ¥ () [] { } & % \ ^ ~ < > = □ §	A B Γ 2	Δ E Z 3	H Θ I 4	K Λ M 5	N Ξ O 6	Π P Σ 7	T Υ Φ 8	X Ψ Ω 9

Extended character table (AÄÄ)

0	1	ABC 2	DEF 3	GHI 4	JKL 5	MNO 6	PQRS 7	TUV 8	WXYZ 9
Space 0	Space . @ / : ; * # + - 1 " ' , ! i ? ¿ _ € £ \$ ¥ () [] { } & % \ ^ ~ < > = □ §	A À Á Á Ä Å À Æ B C Ç 2	D E È É Ê Ë Ë Ì Í Ï 3	G Ğ H I Î Ï 4	J K L 5	M N Ñ O Ò Ó Ô Õ Ö ø 6	P Q R S \$ ß 7	T U Ù Ú Û Ü Û V 8	W X Y Z 9
		a à á â ã ä å æ b c ç 2	d e è é ê ë ë ì í ï 3	g ğ h i î ï ï 4	j k l 5	m n ñ o ò ó ô õ ö ø 6	p q r s \$ ß 7	t u ù ú û ü û v 8	w x y z 9

• The following are used for both uppercase and lowercase:

ø §

Multi-unit Operation

Operating additional units

Additional handsets

Up to 6 handsets can be registered to a single base unit. Additional handsets will give you the freedom to, for example, have an intercom call with another handset while a third handset is on an outside call. See page 5 for information on ordering additional handsets.

Additional base units

Handsets can be registered to up to 4 base units, allowing you to add additional base units and extend the area in which your handset(s) can be used. If a handset moves out of range of its base unit when "Auto" is selected on base unit selection (page 39), it will look for another base unit to make or receive calls. A base unit and the handsets it communicates with is called a "radio cell".

Note:

- Calls will be disconnected when the handset moves from one radio cell to another.
- Intercom calls and call transfers are only possible between handsets in the same radio cell.

Registering a handset to a base unit

To register an additional handset to a base unit (easy registration)

The included handset and base unit are preregistered. After purchasing an additional handset, register it to the base unit. Ensure that the additional handset is switched on. If it is not on, press and hold **[*0]** for few seconds to turn the handset on.

- 1 Lift the additional handset and press **[*0]** to put the handset in standby mode.
- 2 Press and hold **[*]** on the base unit for about 3 seconds, until the registration tone sounds.
- 3 Place the additional handset on the base unit. The registration tone continues to sound. With the handset still on the base unit, wait until a confirmation tone sounds and **Y** stops flashing.

Note:

- If an error tone sounds, or if **Y** is still flashing, register the handset manually (manual registration; page 38).
- If all registered handsets start ringing in step 2, press **[*]** to stop. Start again from step 1.
- Charge the batteries of your additional handset for about 7 hours before initial use.
- This registration method cannot be used for handsets that have already been registered to a base unit. Register the handset manually (manual registration; page 38).

To register a handset to an additional base unit (manual registration)

You can register a handset to a base unit manually using the following method.

- 1 Press **[*]** (middle soft key).
- 2 Select **[*]**, then press **[OK]**.
- 3 Select "Registration", then press **[OK]** 2 times.
- 4 Select a base unit number, then press **[OK]**.
 - This number is used by the handset as a reference only.
- 5 Press and hold **[*]** on the base unit for about 3 seconds, until the registration tone sounds.

Multi-unit Operation

- If all registered handsets start ringing, press **[•••]** to stop, then repeat this step.
 - After pressing **[•••]**, the rest of this procedure must be completed within 1 minute.
- 6** Wait until **“Enter Base PIN”** is displayed, then enter **“0000”** (default base unit PIN), then press **OK**.
- If you changed the PIN, enter it (page 28).
 - When the handset has been registered successfully, **Y** will stop flashing. If keytones are turned on (page 24), a confirmation tone will be heard.
- 3** Enter **“0000”** (default base unit PIN).
- If you changed the PIN, enter it (page 28).
- 4** Enter **“335”**.
- 5** Select **“Cancel Handset”**, then press **OK**.
- The numbers of all handsets registered to the base unit are displayed.
- 6** Select the handset(s) you want to cancel, by pressing the desired handset number.
- The selected handset number(s) will flash.
 - To cancel a selected handset number, press the number again. The number will stop flashing.
- 7** Press **OK**.
- 8** Select **“Yes”**, then press **OK**.
- 9** Press **[↶⊙]**.

Selecting a base unit

When **“Auto”** is selected, the handset will automatically use any available base unit it is registered to. When a specific base unit is selected, the handset will make and receive calls using that base unit only. If the handset is out of range of that base unit, no calls can be made.

- 1** Press **[•••]** (middle soft key).
- 2** Select **↵**, then press **OK**.
- 3** Select **“Select Base”**, then press **OK**.
- 4** Select the desired base unit number, or **“Auto”**, then press **OK**.
 - The handset starts searching for the base unit.

Cancelling a handset

A maximum of 6 handsets can be registered to a base unit. A handset can cancel its own registration (or the registration of another handset) that is stored in the base unit. This will allow the base unit to “forget” the handset.

- 1** Press **[•••]** (middle soft key).
- 2** Select **↵**, then press **OK**.

Cancelling a base unit

A handset can be registered to a maximum of 4 base units. A handset can cancel a base unit that it is registered to. This allows the handset to “forget” the base unit.

- 1** Press **[•••]** (middle soft key).
- 2** Select **↵**, then press **OK**.
- 3** Select **“Registration”**, then press **OK**.
- 4** Enter **“335”**.
- 5** Select **“Cancel Base”**, then press **OK**.
- 6** Enter **“0000”** (default handset PIN).
 - If you changed the PIN, enter it (page 23).
- 7** Select the base unit(s) you want to cancel, by pressing the desired base unit number.
 - The selected base unit number(s) will flash.

Multi-unit Operation

- To cancel a selected base unit number, press the number again. The number will stop flashing.

- 8 Press **OK**.
- 9 Select "Yes", then press **OK**.
- 10 Press [**↶**].

Note:

- To register the handset to another base unit or to the same base unit again, see manual registration (page 38).

Increasing the range of the base unit

You can increase the range of the base unit by using a DECT repeater. Please use only the Panasonic DECT repeater noted on page 5. Consult your Panasonic dealer for details.

Important:

- Before registering the repeater to this base unit, you must turn the repeater mode on.

Turning the repeater mode on/off

- 1 Press **[M]** (middle soft key).
- 2 Select **[A]**, then press **OK**.
- 3 Enter "0000" (default base unit PIN).
 - If you changed the PIN, enter it (page 28).
- 4 Select "Other Options", then press **OK**.
- 5 Select "Repeater Mode", then press **OK**.
- 6 Select "on" or "off", then press **OK**.
- 7 Press [**↶**].

Note:

- After turning repeater mode on/off, you will not be able to make or receive calls for a few moments.

Intercom between handsets

Example: When handset 1 calls handset 2

- 1 **Handset 1:**
Press [**INT**] and [**2**] (desired handset number).
- 2 **Handset 2:**
Press [**↶**] or [**↷**] to answer.
- 3 When finished talking, press [**↶**].

Note:

- Intercom calls can be made between handsets in the same radio cell, but not between handsets in different radio cells.

Transferring calls between handsets, conference calls

Outside calls can be transferred between 2 handsets in the same radio cell. 2 handsets in the same radio cell can have a conference call with an outside party.

Example: When handset 1 transfers a call to handset 2

- 1 **Handset 1:**
During an outside call, press [**INT**] and [**2**] (desired handset number).
 - The outside call will be put on hold.
 - If there is no answer, press [**INT**] to return to the outside call.
- 2 **Handset 2:**
Press [**↶**] or [**↷**] to answer the page.
 - Handset 2 can talk with handset 1.
- 3 **Handset 1:**
To complete the call transfer, press [**↶**].
To establish a conference call, press [**3**].

Multi-unit Operation

Transferring a call without speaking to the other handset user

- 1** During an outside call, press **[INT]**, then press the desired handset number.
 - The other handset rings if it is within range of the base unit and turned on.
- 2** Press **[*⓪]**.
 - The outside call rings at the other handset.

Note:

-  flashes to indicate the outside call is on hold.
- If the other handset user does not answer the call within 1 minute, the call will ring at your handset again.

Useful Information

Wall mounting

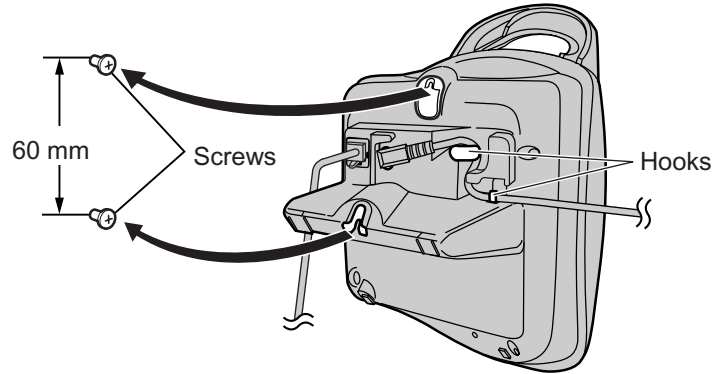

Note:

- Make sure the screws are securely fastened to the wall.
- Do not pinch the telephone line cord and AC adaptor cord between the base unit and the wall.
- Use the following wall template to position the screws before drilling.



Useful Information

Available character entries

Important:

- For character entry when writing SMS messages, see page 36.

The dial keys are used to enter characters and numbers. Each dial key has multiple characters assigned to it. The available character entry modes are, LetterWise, Alphabet, Numeric, Greek, Extended 1, Extended 2, and Cyrillic. When in Alphabet (ABC), Greek (ABΓ), Extended 1 (AÄÅ), Extended 2 (ŠŠŠ), or Cyrillic (АБВ) character entry modes, you can select which character is entered by pressing a dial key repeatedly.

- Press [◀] or [▶] to move the cursor.
- Press dial keys to enter characters and numbers.
- Press [C/✕] to erase the character or number highlighted by the cursor. Press and hold [C/✕] to erase all characters or numbers.
- Press [*] to switch between uppercase and lowercase.
- To enter another character located on the same dial key, press [▶] to move the cursor to the next space, then press the appropriate dial key. (This is not necessary when entering text in LetterWise mode.)

Character entry modes

Several character entry modes are available. Press **1/A/?** (right soft key), then select a character entry mode, and press **OK**. The default setting is Alphabet.

LetterWise character table (for English)

LetterWise is a simplified text entry system which suggests the most likely letter to follow the previously entered text. Text can be input faster because the number of key presses are reduced. You can change which language is used for LetterWise character entry (page 24).

- Each time you press a dial key, LetterWise will suggest a character. If the suggested character is incorrect, press **#** repeatedly to display the desired character.

0	1	ABC 2	DEF 3	GHI 4	JKL 5	MNO 6	PQRS 7	TUV 8	WXYZ 9
Space 0	Space # & ' () * , - . / 1	A B C 2	D E F 3	G H I 4	J K L 5	M N O 6	P Q R S 7	T U V 8	W X Y Z 9
		a b c 2	d e f 3	g h i 4	j k l 5	m n o 6	p q r s 7	t u v 8	w x y z 9

Alphabet character table (ABC)

0	1	ABC 2	DEF 3	GHI 4	JKL 5	MNO 6	PQRS 7	TUV 8	WXYZ 9
Space 0	Space # & ' () * , - . / 1	A B C 2	D E F 3	G H I 4	J K L 5	M N O 6	P Q R S 7	T U V 8	W X Y Z 9
		a b c 2	d e f 3	g h i 4	j k l 5	m n o 6	p q r s 7	t u v 8	w x y z 9

Useful Information

Numeric entry table (0-9)

0	1	ABC 2	DEF 3	GHI 4	JKL 5	MNO 6	PQRS 7	TUV 8	WXYZ 9
0	1	2	3	4	5	6	7	8	9

Greek character table (ΑΒΓ)

0	1	ABC 2	DEF 3	GHI 4	JKL 5	MNO 6	PQRS 7	TUV 8	WXYZ 9
Space 0	Space # & ' () * , - . / 1	A B Γ 2	Δ E Z 3	H Θ I 4	K Λ M 5	N Ξ O 6	Π P Σ 7	Τ Υ Φ 8	X Ψ Ω Ξ 9

Extended 1 character table (AÄÅ)

0	1	ABC 2	DEF 3	GHI 4	JKL 5	MNO 6	PQRS 7	TUV 8	WXYZ 9
Space 0	Space # & ' () * , - . / 1	A Ä Å Ä Å Ä Å Æ B C Ç 2	D E È É Ê Ë Ë F 3	G Ğ H I Ì Í Î Ï Ñ Ò 4	J K L 5	M N Ñ O Ò Ó Ô Ö Ø ø 6	P Q R S Ş ß 7	T U Û Ú Ü Û Ü V 8	W Ŵ X Y ŷ Z 9
		a à á â ã ä å æ b c ç 2	d e è é ê ë ë f 3	g ğ h i ì í î ï ñ ò 4	j k l 5	m n ñ o ò ó ô ö ø ø 6	p q r s ş ß 7	t u ù ú û ü ü v 8	w ŵ x y ŷ z 9

- The following are used for both uppercase and lowercase:

ø Ş Ŵ ŷ

Extended 2 character table (ŠŠš)

0	1	ABC 2	DEF 3	GHI 4	JKL 5	MNO 6	PQRS 7	TUV 8	WXYZ 9
Space 0	Space # & ' () * , - . / 1	A Á Ā Ā B C Ā Ā 2	D Ď E É Ě ě F 3	G H I Í 4	J K L Ĺ Ľ Ļ 5	M N Ń Ń O Ó Ō Ő 6	P Q R Ŕ Ŕ S Š š 7	T Ť U Ú Ů ů ú v 8	W X Y ŷ Ý Z Ž ž Ž 9
		a á ā Ā b c Ā Ā 2	d ě e é ě ě f 3	g h i í 4	j k l ĺ Ĺ Ļ 5	m n Ń ň o ó ō ő 6	p q r ŕ ř s š š 7	t ť u ú ú ů ú v 8	w x y ŷ ý z ž ž ž 9

- The following are used for both uppercase and lowercase:

Ā Ā Ā Ĺ Ĺ Ĺ Ń Ń Ń ŷ ŷ ŷ Ž Ž Ž

Useful Information

Cyrillic character table (АБВ)

0	1	ABC 2	DEF 3	GHI 4	JKL 5	MNO 6	PQRS 7	TUV 8	WXYZ 9
Space 0 Г € ї Ъ	Space # & ' () * , - . / 1	А Б В Г 2	Д Е Ж З 3	И Й К Л 4	М Н О П 5	Р С Т У 6	Ф Х Ц Ч 7	Ш Щ Ъ Ы 8	Ь Э Ю Я 9

Useful Information

Troubleshooting

If you still have difficulties after following the instructions in this section, disconnect the AC adaptor and turn off the handset, then reconnect the AC adaptor and turn on the handset.

Initial settings

Problem	Cause & solution
⏏ is flashing.	<ul style="list-style-type: none"> • The handset is not registered to the base unit. Register it (page 38). • The handset is too far from the base unit. Move closer. • The AC adaptor is not connected. Check the connections.
The handset display is blank.	<ul style="list-style-type: none"> • The handset is not turned on. Turn the power on (page 11).
The handset will not turn on.	<ul style="list-style-type: none"> • Make sure that the batteries are installed correctly (page 10). • Fully charge the batteries (page 10). • Clean the charge contact and charge again (page 10).
The display is dark and displayed items are very faint.	<ul style="list-style-type: none"> • The handset is in screen saver mode (page 11).

Useful Information**Telephone**

Problem	Cause & solution
I cannot make or receive calls.	<ul style="list-style-type: none"> ● The AC adaptor or telephone line cord is not connected. Check the connections. ● If you are using a splitter to connect the unit, remove the splitter and connect the unit to the wall socket directly. If the unit operates properly, check the splitter. ● Disconnect the base unit from the telephone line and connect the line to a known working telephone. If the working telephone operates properly, contact our service personnel to have the unit repaired. If the working telephone does not operate properly, contact your service provider. ● The dialling mode setting is incorrect. Set to "Tone" or "Pulse" as needed (page 27). ● The call bar feature is turned on. Turn it off (page 23). ● You dialled a call restricted number (page 28). ● The key lock feature is turned on. Turn it off (page 14).
The unit does not ring.	<ul style="list-style-type: none"> ● The ringer volume is turned off. Adjust the handset ringer volume (page 20) and the base unit ringer volume (page 26). ● The night mode feature is turned on. Turn it off (page 21, 26).
The batteries should be charging but the battery icon does not change.	<ul style="list-style-type: none"> ● Clean the charge contact and charge again (page 10). ● The AC adaptor is disconnected. Plug in the AC adaptor.
A busy tone is heard when  is pressed.	<ul style="list-style-type: none"> ● The handset is too far from the base unit. Move closer and try again. ● Another handset is on an outside call. Wait for the other user to complete the call.
Static is heard, sound cuts in and out. Interference from other electrical units.	<ul style="list-style-type: none"> ● Locate the handset and the base unit away from other electrical appliances. ● Move closer to the base unit. ● Your unit is connected to a telephone line with DSL service. We recommend connecting a filter (contact your DSL service provider) to the telephone line between the base unit and the telephone line jack.

Useful Information

Problem	Cause & solution
The handset stops working while being used.	<ul style="list-style-type: none"> ● Disconnect the AC adaptor and turn off the handset. Connect the AC adaptor, turn on the handset and try again.
While storing an entry in the phonebook or assigning a one touch dial, the handset starts to ring.	<ul style="list-style-type: none"> ● A call is being received. To answer the call, press [↶]. Programming will be cancelled. Start again.
Pressing [↶] does not display/dial the last number dialled.	<ul style="list-style-type: none"> ● The redialled number was more than 24 digits long. Redial the number manually.
The handset beeps intermittently and/or [↶] flashes.	<ul style="list-style-type: none"> ● Fully charge the batteries (page 10).
I fully charged the batteries, but [↶] still flashes.	<ul style="list-style-type: none"> ● Clean the charge contact and charge again (page 10). ● It is time to replace the batteries (page 11).
Caller information is not displayed.	<ul style="list-style-type: none"> ● You must subscribe to Caller ID service. ● Your unit is connected to a telephone line with DSL service. We recommend connecting a filter (contact your DSL service provider) to the telephone line between the base unit and the telephone line jack.
While viewing caller information, the display returns to standby mode.	<ul style="list-style-type: none"> ● Do not pause for over 1 minute while searching.
I cannot register a handset to a base unit.	<ul style="list-style-type: none"> ● The maximum number of base units (4) are already registered to the handset. Cancel unused base unit registrations from the handset (page 39). ● The maximum number of handsets (6) are already registered to the base unit. Cancel unused handset registrations from the base unit (page 39). ● You entered the wrong PIN number. If you forget your PIN, consult your nearest Panasonic service centre. ● Locate the handset and the base unit away from other electrical appliances.

Useful Information**SMS (Short Message Service)**

Problem	Cause & solution
I cannot send or receive SMS messages.	<ul style="list-style-type: none"> ● You have not subscribed to the appropriate service. Consult your service provider. ● The SMS message centre number(s) are not stored or are incorrect. Store the correct numbers (page 32). ● Message transmission was interrupted. Wait until the message has been sent before using other telephone functions. ● SMS message memory is full. Erase unnecessary message in the receive and send lists (page 34). ● Your unit is connected to a telephone line with DSL service. We recommend connecting a filter (contact your DSL service provider) to the telephone line between the base unit and the telephone line jack.
"FD" is displayed.	<ul style="list-style-type: none"> ● The unit could not connect to the SMS message centre. Confirm that the correct SMS message centre numbers are stored (page 32). Confirm that SMS is turned on (page 32).
"FE" is displayed.	<ul style="list-style-type: none"> ● An error occurred while sending the message. Try again.
"E0" is displayed.	<ul style="list-style-type: none"> ● Your phone number is permanently withheld or you have not subscribed to the appropriate service. Consult your service provider.
"✓" is not displayed after you read a message. An error code ("FD", "FE", or "E0") is displayed.	<ul style="list-style-type: none"> ● When an error code is displayed, "✓" will not be displayed even if you have read the message.

Useful Information

Specifications

■ **Standard:**

DECT (Digital Enhanced Cordless Telecommunications),
GAP (Generic Access Profile)

■ **Number of channels:**

120 Duplex Channels

■ **Frequency range:**

1.88 GHz to 1.9 GHz

■ **Duplex procedure:**

TDMA (Time Division Multiple Access)

■ **Channel spacing:**

1,728 kHz

■ **Bit rate:**

1,152 kbit/s

■ **Modulation:**

GFSK (Gaussian Frequency Shift Keying)

■ **RF transmission power:**

Approx. 250 mW

■ **Power source:**

220–240 V, 50 Hz

■ **Power consumption, Base unit:**

Standby: Approx. 3.5 W
Maximum: Approx. 9.2 W

■ **Operating conditions:**

5 °C–40 °C, 20 %–80 % relative air humidity
(dry)

■ **Dimensions:**

Base unit: Approx. 111 mm × 121 mm × 123 mm

Handset: Approx. 148 mm × 48 mm × 32 mm

■ **Mass (weight):**

Base unit: Approx. 200 g

Handset: Approx. 130 g

Note:

- Specifications are subject to change.
- The illustrations used in these operating instructions may differ slightly from the actual product.

Connections:

The unit will not work during a power failure. We recommend you connect a standard telephone on the same line for power protection.

Index

- A** Alarm: 20
 - Answering calls: 15
 - Auto talk: 15, 23
- B** Base unit
 - Additional base units: 38
 - Cancelling: 39
 - PIN: 28
 - Resetting: 28
 - Selecting: 39
 - Settings: 25
- Battery
 - Charge: 10
 - Installation: 10
 - Life: 11
 - Replacement: 11
 - Strength: 10
- C** Call bar: 23
 - Caller ID service: 30
 - Call restriction: 28
 - Category: 16
 - Display colours: 30
 - Ringtones: 30
 - Chain dial: 18
 - Character entry: 43
 - Character entry for SMS: 43
 - Conference calls: 40
 - Connections: 9
- D** Date and time: 12
 - Dialling mode: 27
 - Display
 - Colour: 22
 - Contrast: 23
 - Icons: 7
 - Language: 23
 - Standby mode: 22
- E** Emergency numbers: 27
- H** Handset
 - Additional handsets: 38
 - Cancelling: 39
 - Locator: 15
 - PIN: 23
 - Power on/off: 11
 - Registration: 38
 - Resetting: 24
 - Settings: 19
- I** Intercom: 40
- K** Key lock: 14
 - Keytones: 24
- L** LetterWise: 24, 36, 43
- M** Making calls: 13
 - Missed calls: 30
 - Mute: 14
- N** Night mode
 - Base unit: 26
 - Handset: 21
- O** One touch dial: 17
- P** Pause: 15, 27
 - Phonebook: 16
 - Copying: 18
 - Editing: 17
 - Erasing: 17
 - Making calls: 16
 - Storing: 16
 - PIN
 - Base unit: 28
 - Handset: 23
 - Power on/off: 11
- R** Recall: 15, 27
 - Redialling: 13
 - Redial list: 13
 - Registration: 38
 - Repeater: 40
 - Ringtones: 20
- S** Screen saver mode: 11
 - SMS feature: 32
 - Speakerphone: 13
- T** Temporary tone dialling: 15
 - Transfer calls: 40
- V** Voice enhancer: 14
 - Volume
 - Receiver: 13
 - Ringer (Base unit): 26
 - Ringer (Handset): 20
 - Speakerphone: 13
- W** Wall mounting: 42
 - Wallpaper: 22

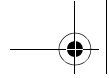

CE0436

1999/5/EC

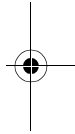
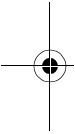

Panasonic Communications Zhuhai Co., Ltd.

3 Ping Xi 8 Lu, Nanping Keji Gongye Yuan, Zhuhai, Guangdong, China 519060

Copyright:

This material is copyrighted by Panasonic Communications Co., Ltd., and may be reproduced for internal use only. All other reproduction, in whole or in part, is prohibited without the written consent of Panasonic Communications Co., Ltd.

© 2004 Panasonic Communications Co., Ltd. All Rights Reserved.

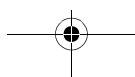
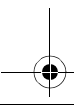

PQQX14388ZA CC1004DS0

