

# LCD Digital Colour TV



## Operating Instructions

-  Before operating the TV, please read the “Safety information” section of this manual.  
Retain this manual for future reference.

**KDL-52X3500**  
**KDL-46X3500 KDL-46X3000**  
**KDL-40X3500 KDL-40X3000**

# BRAVIA



For useful information about Sony products  
<http://www.sony-europe.com/myproduct/>

## Introduction

Thank you for choosing this Sony product. Before operating the TV, please read this manual thoroughly and retain it for future reference.

## NOTICE FOR CUSTOMERS IN THE UNITED KINGDOM

A moulded plug complying with BS1363 is fitted to this equipment for your safety and convenience. Should the fuse in the plug supplied need to be replaced with the same rating of fuse approved by ASTA or BSI to BS 1362 (i.e., marked with ⚡ or ⚡) must be used. When an alternative type of plug is used it should be fitted with the same rating of fuse, otherwise the circuit should be protected by a 13 AMP FUSE at the distribution board. If the plug supplied with this equipment has a detachable fuse cover, be sure to attach the fuse cover after you change the fuse. Never use the plug without the fuse cover. If you should lose the fuse cover, please contact your nearest Sony service station.

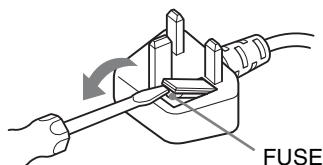

## How to replace the fuse

Open the fuse compartment with a blade screwdriver, and replace the fuse.

## Disposal of the TV set



### Disposal of Old Electrical & Electronic Equipment (Applicable in the European Union and other European countries with separate collection systems)

This symbol on the product or on its packaging indicates that this product shall not be treated as household waste. Instead it shall be handed over to the applicable collection point for the recycling of electrical and electronic

equipment. By ensuring this product is disposed of correctly, you will help prevent potential negative consequences for the environment and human health, which could otherwise be caused by inappropriate waste handling of this product. The recycling of materials will help to conserve natural resources. For more detailed information about recycling of this product, please contact your local Civic Office, your household waste disposal service or the shop where you purchased the product.

The manufacturer of this product is Sony Corporation, 1-7-1 Konan Minato-ku Tokyo, 108-0075 Japan. The Authorized Representative for EMC and product safety is Sony Deutschland GmbH, Hedelfinger Strasse 61, 70327 Stuttgart, Germany. For any service or guarantee matters please refer to the addresses given in separate service or guarantee documents.

## Notice for Digital TV function

- Any functions related to Digital TV (**DVB**) will only work in countries or areas where DVB-T (MPEG2 and MPEG4 AVC) digital terrestrial signals are broadcast or where you have access to a compatible DVB-C (MPEG2 and MPEG4 AVC) cable service. Please confirm with your local dealer if you can receive a DVB-T signal where you live or ask your cable provider if their DVB-C cable service is suitable for integrated operation with this TV.
- The cable provider may charge an additional fee for such services and you may be required to agree to their terms and conditions of business.
- Although this TV set follows DVB-T and DVB-C specifications, compatibility with future DVB-T digital terrestrial and DVB-C digital cable broadcasts cannot be guaranteed.
- Some Digital TV functions may not be available in some countries/regions and DVB-C cable may not operate correctly with some providers.

For a list of compatible cable providers, refer to the support web site:  
<http://support.sony-europe.com/TV/DVBC/>

## Trademark information

- **DVB** is a registered trademark of the DVB Project
- HDMI, the HDMI logo and High-Definition Multimedia Interface are trademarks or registered trademarks of HDMI Licensing LLC.
- Adobe is a registered trademark or a trademark of Adobe Systems Incorporated in the United States and/or other countries.
- Manufactured under license from Dolby Laboratories. "Dolby" and the double-D symbol are trademarks of Dolby Laboratories.

**HDMI**™  
HIGH-DEFINITION MULTIMEDIA INTERFACE

**DOLBY**®  
DIGITAL • PLUS

The illustrations used in this manual are of the KDL-40X3500 unless otherwise stated.

---

# Table of Contents

## Start-up Guide

4

Safety information .....	9
Precautions .....	11
<b>Overview of the remote .....</b>	<b>12</b>
<b>Overview of the TV buttons and indicators .....</b>	<b>14</b>

## Watching TV

Watching TV .....	15
Using the Digital Electronic Programme Guide (EPG) <b>DVB</b> .....	17
Using the Digital Favourite list <b>DVB</b> .....	19

## Using Optional Equipment

Connecting optional equipment.....	20
Viewing pictures from the connected equipment .....	22
Using the remote.....	23
Using USB photo viewer .....	26
Using HDMI control.....	26

## Using Menu Functions

Navigating through menus .....	27
Picture menu .....	28
Sound menu .....	30
Screen menu (except for PC input) .....	32
Screen menu (for PC input) .....	33
Video Settings menu .....	34
Audio Settings menu .....	36
Set-up menu.....	37
Analogue Set-up menu .....	40
Digital Set-up menu <b>DVB</b> .....	43

## Additional Information

Specifications .....	46
Cleaning .....	48
Troubleshooting .....	48

**DVB** : for digital channels only

# Start-up Guide

## 1: Checking the accessories

Mains lead (Type BF)\* (1)

Coaxial cable\* (1)

PC cable\* (1)

Support belt (1) and screws (2)

Stand (1) and screws (4) (only for KDL-46X3500/40X3500/46X3000/40X3000)

Remote RM-ED010 (1)

Size AA batteries (R6 type) (2)

\* Do not remove the ferrite cores.

### To insert batteries into the remote

Push and slide to open.

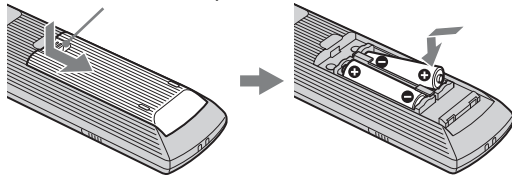

- Observe the correct polarity when inserting batteries.
- Do not use different types of batteries together or mix old and new batteries.
- Dispose of batteries in an environmentally friendly way. Certain regions may regulate the disposal of batteries. Please consult your local authority.
- Handle the remote with care. Do not drop or step on it, or spill liquid of any kind onto it.
- Do not place the remote in a location near a heat source, a place subject to direct sunlight, or a damp room.

### To replace the bezel unit (only for KDL-46X3000/40X3000)

The bezel unit can be replaced with others that are sold separately. However, do not remove the unit except to replace it. For details, see the instructions supplied with bezel units.

## 2: Attaching the stand (except for KDL-52X3500)

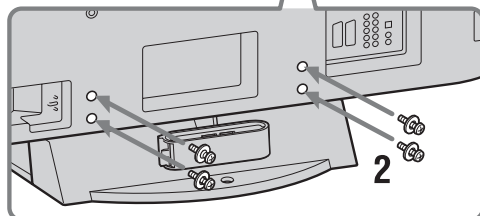
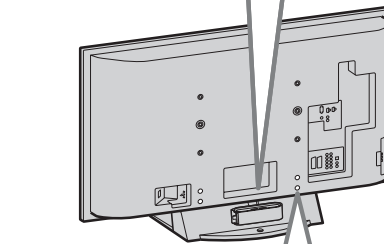
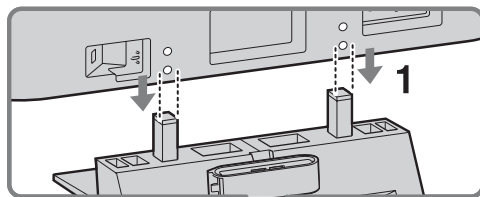

- 1 Place the TV onto the stand by aligning the screw hole alignment lines over the stand as shown.
- 2 Fix the TV to the stand using the supplied screws.



- This TV is very heavy, so two or more people should place the TV on the stand.
- If using an electric screwdriver, set the tightening torque at approximately 1.5 N·m (15 kgf·cm).

### 3: Connecting an aerial/cable/VCR

#### Connecting an aerial/cable

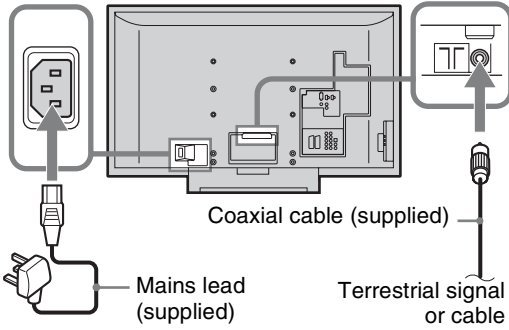

#### Connecting an aerial/cable and VCR

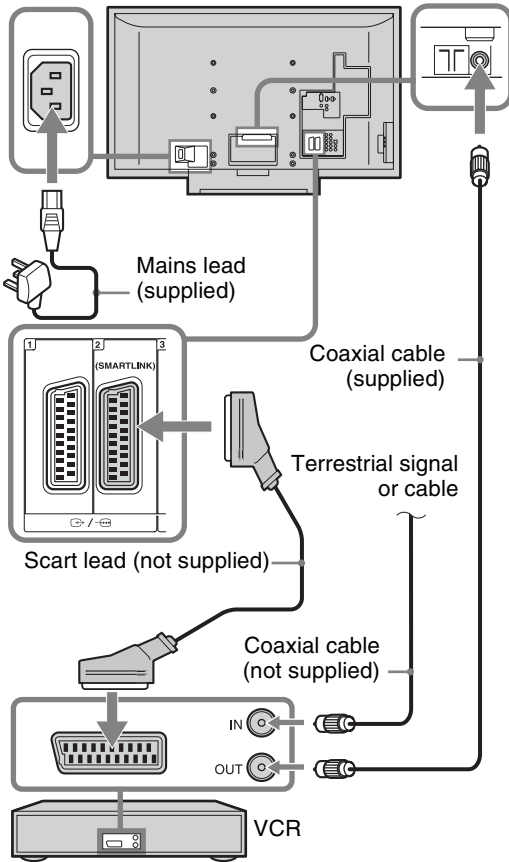

### 4: Preventing the TV from toppling over

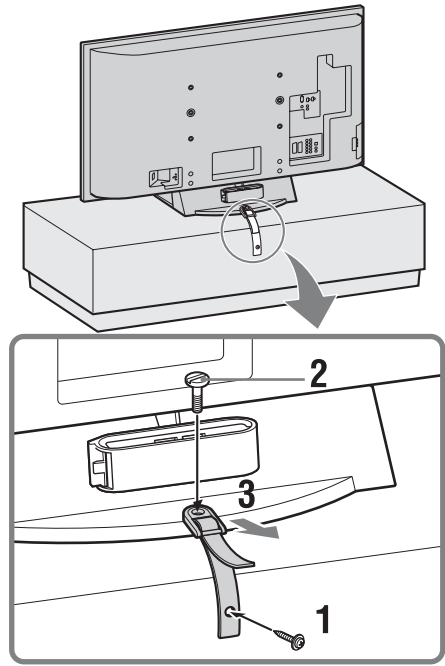

## 5: Bundling the cables

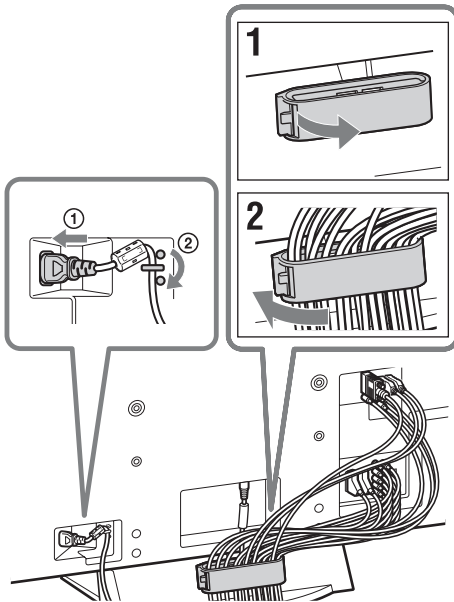

The hook of the cable holder can be opened from either sides depending on attaching position.

## 6: Performing the initial set-up

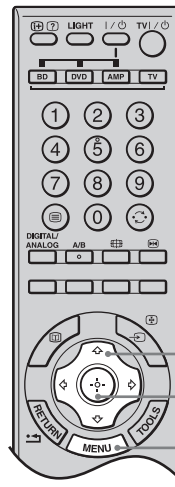
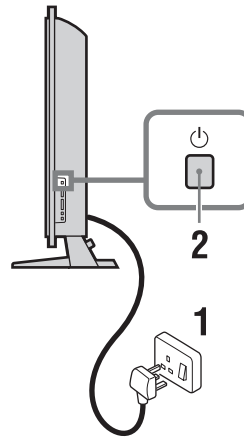

3, 4, 6, 7

3, 4, 6, 7

9

### Selecting the language and country/region

- 1 Connect the TV to your mains socket (220–240 V AC, 50 Hz).
- 2 Press  on the right side of the TV. When you turn on the TV for the first time, the Language menu appears on the screen.

- 3 Press  $\uparrow/\downarrow/\leftarrow/\rightarrow$  to select the language displayed on the menu screens, then press  $\oplus$ .



- 4 Press  $\uparrow/\downarrow$  to select the country/region in which you will operate the TV, then press  $\oplus$ .

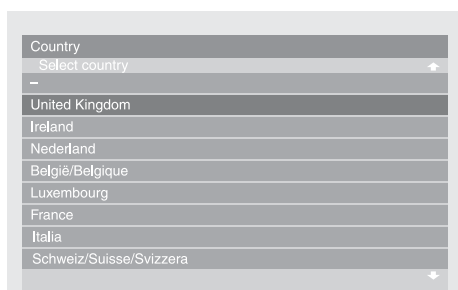

If the country/region which you want to use on the TV does not appear in the list, select “-” instead of a country/region.

## Auto tuning the TV

- 5 Before you start auto tuning the TV, insert a pre-recorded tape into the VCR connected to the TV (page 5) and start play back.

The video channel will be located and stored on the TV during auto tuning.

If no VCR is connected to the TV, skip this step.

- 6 Press  $\leftarrow/\rightarrow$  to select “OK”, then press  $\oplus$ .

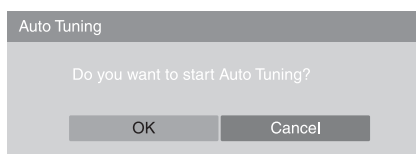

- 7 Press  $\uparrow/\downarrow$  to select “Antenna” or “Cable”, then press  $\oplus$ .

If you select “Cable”, the screen for selecting the scan type appears. See “To tune the TV for digital cable connection” on page 7.

The TV starts searching for all available digital channels, followed by all available analogue channels. This may take some time, so do not press any buttons on the TV or remote while proceeding.

### If a message appears for you to confirm the aerial connection

No digital or analogue channels were found.

Check all the aerial connections and press  $\oplus$  to start auto tuning again.

- 8 When the Programme Sorting menu appears on the screen, follow the steps of “Programme Sorting” on page 40.

If you do not wish to change the order in which the analogue channels are stored on the TV, go to next step.

- 9 Press MENU to exit.

The TV has now tuned in all the available channels.



When a digital broadcast channel cannot be received, or when selecting a country/region in which there are no digital broadcasts in step 4 (page 7), the time must be set after performing step 9.

## To tune the TV for digital cable connection

- 1 Press  $\uparrow/\downarrow$  to select “Scan Type”, then press  $\oplus$ .

- 2 Press  $\uparrow/\downarrow$  to select “Quick Scan” or “Full Scan”, then press  $\oplus$ .

“**Quick Scan**”: Channels are tuned according to the cable provider’s information within the broadcast signal. The recommended setting for “Frequency”, “Network ID” and “Symbol Rate” is “Auto” unless your cable provider has supplied actual values to use. “Quick Scan” is recommended for fast tuning when this is supported by your cable provider.

“**Full Scan**”: All available channels are tuned and stored. This procedure may take some time. This option is recommended when “Quick Scan” is not supported by your cable provider.

For further information about supported cable providers, refer to the support web site:  
<http://support.sony-europe.com/TV/DVBC/>

- 3 Press  $\leftarrow/\rightarrow/\downarrow$  to select “Start”, then press  $\oplus$ .

The TV starts searching for channels. Do not press any buttons on the TV or remote.



Some cable providers do not support “Quick Scan”. If no channels are detected using “Quick Scan”, perform “Full Scan”.

---

# Detaching the Table-Top Stand from the TV



Do not remove the Table-Top Stand for any reason other than to wall-mount the TV or to set the optional TV stand.

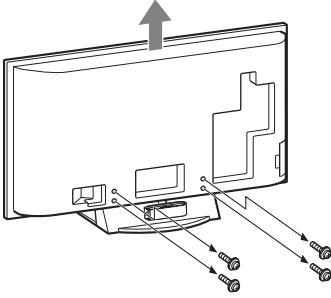



# Safety information

## Installation/Set-up

Install and use the TV set in accordance with the instructions below in order to avoid any risk of fire, electrical shock or damage and/or injuries.

### Installation

- The TV set should be installed near an easily accessible mains socket.
- Place the TV set on a stable, level surface.
- Only qualified service personnel should carry out wall installations.
- For safety reasons, it is strongly recommended that you use Sony accessories, including:
  - KDL-52X3500/46X3500/40X3500/46X3000/40X3000:
    - Wall-mount bracket SU-WL500
    - KDL-52X3500/46X3500/40X3500/46X3000/40X3000:
      - Floor stand SU-FL62

### Transporting

- Before transporting the TV set, disconnect all cables.
- Two or three people are needed to transport a large TV set.
- When transporting the TV set by hand, hold it as shown on the right. Do not put stress on the LCD panel and frame around the screen.
- When lifting or moving the TV set, hold it firmly from the bottom.
- When transporting the TV set, do not subject it to jolts or excessive vibration.
- When transporting the TV set for repairs or when moving, pack it using the original carton and packing material.

except for KDL-52X3500

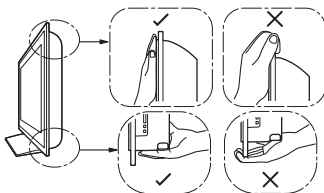
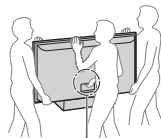
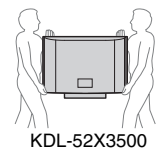

### Ventilation

- Never cover the ventilation holes or insert anything in the cabinet.
- Leave space around the TV set as shown below.
- It is strongly recommended that you use a Sony wall-mount bracket in order to provide adequate air-circulation.

### Installed on the wall

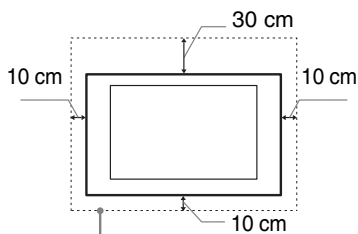

Leave at least this space around the set.

### Installed with stand

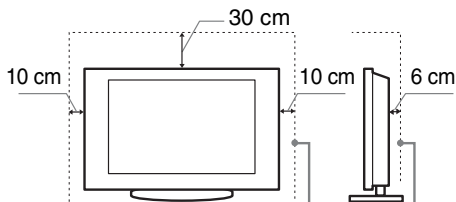

Leave at least this space around the set.

- To ensure proper ventilation and prevent the collection of dirt or dust:
  - Do not lay the TV set flat, install upside down, backwards, or sideways.
  - Do not place the TV set on a shelf, rug, bed or in a closet.
  - Do not cover the TV set with a cloth, such as curtains, or items such as newspapers, etc.
  - Do not install the TV set as shown below.

Air circulation is blocked.

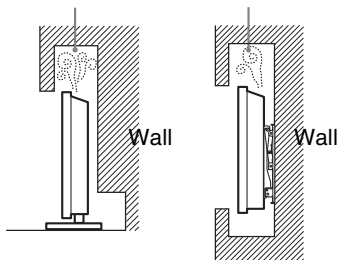

### Mains lead

Handle the mains lead and socket as follows in order to avoid any risk of fire, electrical shock or damage and/or injuries:

- Connect the TV set using a three-wire grounding type mains plug to a mains socket with a protective earthing connection.
- Use only Sony mains leads, not those of other brands.
- Insert the plug fully into the mains socket.
- Operate the TV set on a 220–240 V AC supply only.
- When wiring cables, be sure to unplug the mains lead for your safety and take care not to catch your feet on the cables.
- Disconnect the mains lead from the mains socket before working on or moving the TV set.
- Keep the mains lead away from heat sources.

*Continued*

- Unplug the mains plug and clean it regularly. If the plug is covered with dust and it picks up moisture, its insulation may deteriorate, which could result in a fire.

### Notes

- Do not use the supplied mains lead on any other equipment.
- Do not pinch, bend, or twist the mains lead excessively. The core conductors may be exposed or broken.
- Do not modify the mains lead.
- Do not put anything heavy on the mains lead.
- Do not pull on the mains lead itself when disconnecting the mains lead.
- Do not connect too many appliances to the same mains socket.
- Do not use a poor fitting mains socket.

### Prohibited Usage

Do not install/use the TV set in locations, environments or situations such as those listed below, or the TV set may malfunction and cause a fire, electrical shock, damage and/or injuries.

#### Location:

Outdoors (in direct sunlight), at the seashore, on a ship or other vessel, inside a vehicle, in medical institutions, unstable locations, near water, rain, moisture or smoke.

#### Environment:

Places that are hot, humid, or excessively dusty; where insects may enter; where it might be exposed to mechanical vibration, near flammable objects (candles, etc). The TV set shall not be exposed to dripping or splashing and no objects filled with liquids, such as vases, shall be placed on the TV.

#### Situation:

Do not use when your hands are wet, with the cabinet removed, or with attachments not recommended by the manufacturer. Disconnect the TV set from mains socket and aerial during lightning storms.

### Broken pieces:

- Do not throw anything at the TV set. The screen glass may break by the impact and cause serious injury.
- If the surface of the TV set cracks, do not touch it until you have unplugged the mains lead. Otherwise electric shock may result.

### When not in use

- If you will not be using the TV set for several days, the TV set should be disconnected from the mains for environmental and safety reasons.
- As the TV set is not disconnected from the mains when the TV set is just turned off, pull the plug from the mains to disconnect the TV set completely.
- However, some TV sets may have features that require the TV set to be left in standby to work correctly. The instructions in this manual will inform you if this applies.

### For children

- Do not allow children to climb on the TV set.
- Keep small accessories out of the reach of children, so that they are not mistakenly swallowed.

### If the following problems occur...

**Turn off** the TV set and unplug the mains lead immediately if any of the following problems occur. Ask your dealer or Sony service centre to have it checked by qualified service personnel.

#### When:

- Mains lead is damaged.
- Poor fitting of mains socket.
- TV set is damaged by being dropped, hit or having something thrown at it.
- Any liquid or solid object falls through openings in the cabinet.

---

# Precautions

## Viewing the TV

- View the TV in moderate light, as viewing the TV in poor light or during long period of time, strains your eyes.
- When using headphones, adjust the volume so as to avoid excessive levels, as hearing damage may result.

## LCD Screen

- Although the LCD screen is made with high-precision technology and 99.99% or more of the pixels are effective, black dots may appear or bright points of light (red, blue, or green) may appear constantly on the LCD screen. This is a structural property of the LCD screen and is not a malfunction.
- Do not push or scratch the front filter, or place objects on top of this TV set. The image may be uneven or the LCD screen may be damaged.
- If this TV set is used in a cold place, a smear may occur in the picture or the picture may become dark. This does not indicate a failure. These phenomena disappear as the temperature rises.
- Ghosting may occur when still pictures are displayed continuously. It may disappear after a few moments.
- The screen and cabinet get warm when this TV set is in use. This is not a malfunction.
- The LCD screen contains a small amount of liquid crystal and mercury. The fluorescent tubes used in this TV set also contain mercury. Follow your local ordinances and regulations for disposal.

## Handling and cleaning the screen surface/cabinet of the TV set

Be sure to unplug the mains lead connected to the TV set from mains socket before cleaning.

To avoid material degradation or screen coating degradation, observe the following precautions.

- To remove dust from the screen surface/cabinet, wipe gently with a soft cloth. If dust is persistent, wipe with a soft cloth slightly moistened with a diluted mild detergent solution.
- Never use any type of abrasive pad, alkaline/acid cleaner, scouring powder, or volatile solvent, such as alcohol, benzene, thinner or insecticide. Using such materials or maintaining prolonged contact with rubber or vinyl materials may result in damage to the screen surface and cabinet material.
- When adjusting the angle of the TV set, move it slowly so as to prevent the TV set from moving or slipping off from its table stand.

## Optional Equipment

Keep optional components or any equipment emitting electromagnetic radiation away from the TV set. Otherwise picture distortion and/or noisy sound may occur.

# Overview of the remote

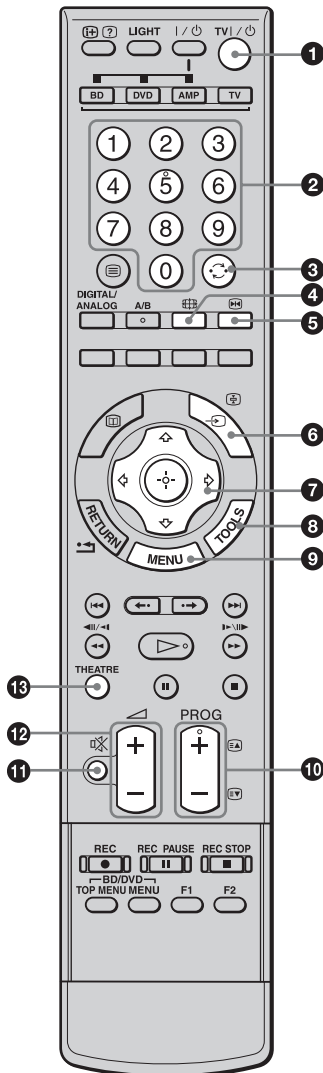

- 1 TV I/⏻ — TV standby**  
 Turns the TV on and off from standby mode.
- 2 Number buttons**
  - In TV mode: Selects channels. For channel numbers 10 and above, enter the second and third digit quickly.
  - In Text mode: Enters the page number to select the page.
- 3 ↻ — Previous channel**  
 Returns to the previous channel watched (for more than five seconds).
- 4 🌐 — Screen mode (page 16)**
- 5 📺 — Picture freeze (page 15)**  
 Freezes the TV picture.
- 6 ↔/📄 — Input select / Text hold**
  - In TV mode (page 22): Selects the input source from equipment connected to the TV sockets.
  - In Analogue Text mode (page 16): Holds the current page.
- 7 ⬆/⬇/⬅/➡/⬆/⬇/⬅/➡/⊕ (page 15, 27)**
- 8 TOOLS (page 16, 22)**  
 Enables you to access various viewing options and change/make adjustments according to the source and screen format.
- 9 MENU (page 27)**
- 10 PROG +/-/⏪/⏩**
  - In TV mode (page 15): Selects the next (+) or previous (-) channel.
  - In Analogue Text mode (page 16): Selects the next (⏪) or previous (⏩) page.
- 11 📴 — Mute (page 15, 22)**
- 12 🔊 +/- — Volume (page 22)**
- 13 THEATRE**  
 You can set Theatre Mode on or off. When Theatre Mode is set to on, the optimum audio output (if the TV is connected with an audio system using an HDMI cable) and picture quality for film-based contents are automatically set.  
  
 If you turn the TV off, Theatre Mode is also turned off.

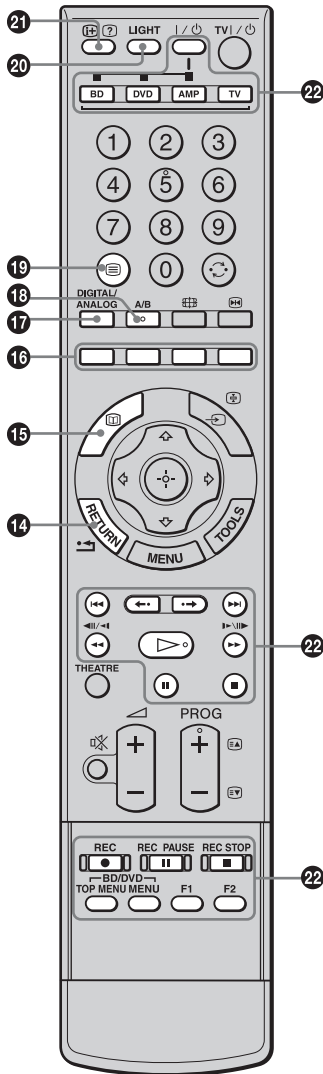

**14 RETURN / ↶**

Returns to the previous screen of any displayed menu.

**15** — **EPG (Digital Electronic Programme Guide) (page 17)**

**16** **Coloured buttons (page 16, 17, 19)**

**17** **DIGITAL/ANALOG — TV mode (page 15)**

**18** **A/B — Dual Sound (page 31)**

**19** — **Text (page 15)**

**20** **LIGHT**

Lightens the buttons on the remote so that you can control them easily even if the room is dark.

**21** — **Info / Text reveal**

- In digital mode: Displays brief details of the programme currently being watched.
- In analogue mode: Displays information such as current channel number and screen format.
- In Analogue Text mode (page 16): Reveals hidden information (e.g. answers to a quiz).

**22** **Buttons for using optional equipment**

See page 23.



The number 5, , PROG + and A/B buttons have tactile dots. Use the tactile dots as references when operating the TV.

# Overview of the TV buttons and indicators

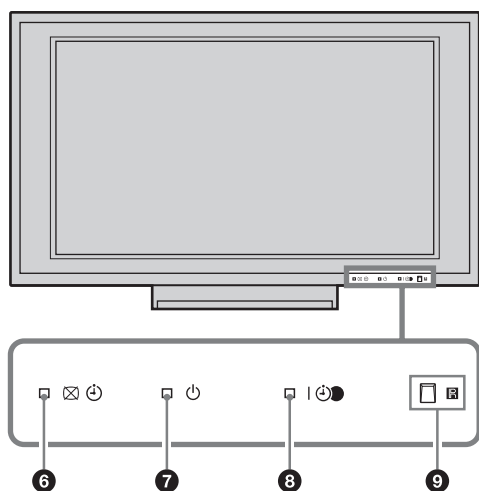
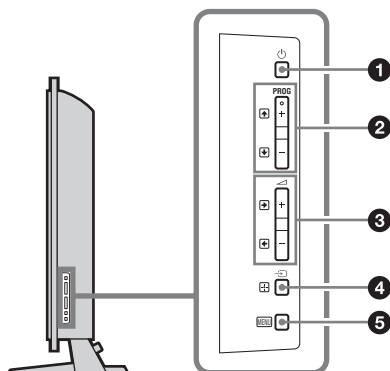



## 1 — Power

Turns the TV on or off.





To disconnect the TV completely, pull the plug from the mains.

## 2 **PROG** +/-/

- In TV mode: Selects the next (+) or previous (-) channel.
- In TV menu: Moves through the options up () or down ()

## 3 +/-/

- In TV mode: Increases (+) or decreases (-) the volume.
- In TV menu: Moves through the options right () or left ()

## 4 — Input select / OK

- In TV mode (page 22): Selects the input source from equipment connected to the TV sockets.
- In TV menu: Selects the menu or option, and confirms the setting.

## 5 **MENU** (page 27)

## 6 — Picture Off / Timer indicator

- Lights up in green when the picture is switched off (page 38).
- Lights up in orange when the timer is set (page 37).

## 7 — Standby indicator

Lights up in red when the TV is in standby mode.

## 8 — Power / Timer REC programme indicator

- Lights up in green when the TV is turned on.
- Lights up in orange when the timer recording is set (page 17).
- Lights up in red during the timer recording.

## 9 **Remote control sensor / Light sensor** (page 38)



- Receives IR signals from the remote.
- Do not put anything over the sensor, as its function may be affected.

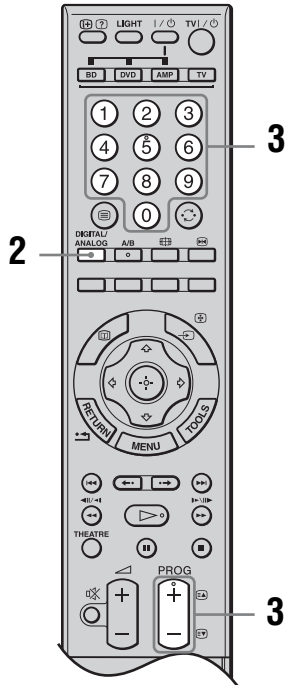
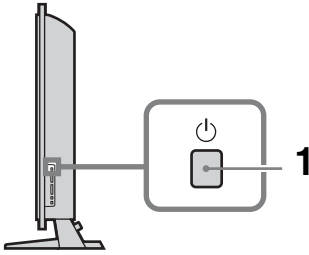

Make sure that the TV is completely turned off before unplugging the mains lead. Unplugging the mains lead while the TV is turned on may cause the indicator to remain lit or may cause the TV to malfunction.

# Watching TV













- 1** Press  on the right side of the TV to turn on the TV.  
When the TV is in standby mode (the  (standby) indicator on the TV front panel is red), press TV  on the remote to turn on the TV.
- 2** Press DIGITAL/ANALOG to switch between digital and analogue modes.  
The channels available vary depending on the mode.
- 3** Press the number buttons or PROG +/- to select a TV channel.  
To select channel numbers 10 and above using the number buttons, enter the second and third digits quickly.









To select a digital channel using the Digital Electronic Programme Guide (EPG), see page 17.

### In digital mode

An information banner appears briefly. The following icons may be indicated on the banner.

- : HD service
- : Interactive service is available (Digital Text)
- : Radio service
- : Scrambled/Subscription service
- : Subtitles available
- : Subtitles available for the hearing impaired
- : Multiple audio languages available
- : Recommended minimum age for current programme (from 4 to 18 years)
- : Parental Lock
-  (in red): Current programme is being recorded

### Additional operations

To	Press
Freeze the picture (Picture freeze)	 Press again to return to normal TV mode.   This function is not available for a PC input source.
Access the Programme index table (in analogue mode only)	 To select an analogue channel, press  , then press  .
Access the Digital Favourites (in digital mode only)	 For details, see page 19.
Mute the sound	 Press again to restore.
Turn on the TV without sound from standby mode	

### To access Digital Text

Many broadcasters provide a Digital Text service. Digital Text offers graphically rich contents, compared to Analogue Text. Select a digital channel which provides Digital Text, then press .  
When a broadcaster provides a dedicated Digital Text channel, select this channel to access Digital Text. To navigate through Digital Text, follow the instructions on the screen.

*Continued*

To exit Digital Text, press RETURN.  
 To move around, press  $\uparrow/\downarrow/\leftarrow/\rightarrow$ .  
 To select items, press  $\oplus$  and the number buttons.  
 To access shortcuts, press the coloured buttons.

## To access Analogue Text

In analogue mode, press  $\equiv$ . Each time you press  $\equiv$ , the display changes cyclically as follows:  
 Text and TV picture  $\rightarrow$  Text  $\rightarrow$  No Text (exit the Text service)  
 To select a page, press the number buttons or  $\text{EA}/\text{EV}$ .  
 To hold a page, press  $\text{H}/\text{L}$ .  
 To reveal hidden information, press  $\text{FH}/\text{?}$ .  
 To jump a page, press  $\oplus$  and  $\uparrow/\downarrow$ , then press  $\oplus$  (for three digit pages).



When four coloured items appear at the bottom of the Text page, Fastext is available. Fastext allows you to access pages quickly and easily. Press the corresponding coloured button to access the page.

## To change the screen format manually to suit the broadcast

Press  $\text{FB}$  repeatedly to select the desired screen format.

### Smart\*

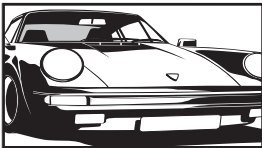

Displays conventional 4:3 broadcasts with an imitation wide screen effect. The 4:3 picture is stretched to fill the screen.

### 4:3

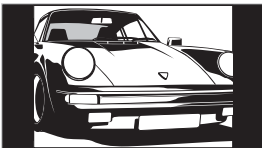

Displays conventional 4:3 broadcasts (e.g. non-wide screen TV) in the correct proportions.

### Wide

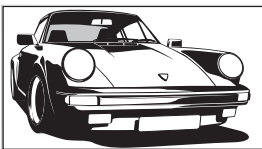

Displays wide screen (16:9) broadcasts in the correct proportions.

### Zoom\*

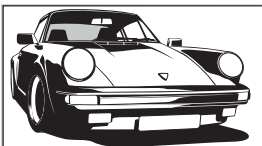

Displays cinemascopic (letter box format) broadcasts in the correct proportions.

### 14:9\*

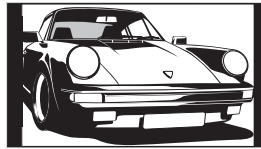

Displays 14:9 broadcasts in the correct proportions. As a result, black border areas are visible on the screen.

\* Parts of the top and bottom of the picture may be cut off.



Some characters and/or letters at the top and the bottom of the picture may not be visible in "Smart". In such a case, you can select "Vertical Size" using the "Screen" menu and adjust vertical size to make it visible.



- When "Auto Format" is set to "On", the TV will automatically select the best mode to suit the broadcast (page 32).
- You can adjust the position of the picture when selecting "Smart" (50Hz), "Zoom" or "14:9". Press  $\uparrow/\downarrow$  to move up or down (e.g. to read subtitles).
- Select "Smart" or "Zoom" to adjust for 720p, 1080i or 1080p source pictures with edge portions cut off.

## Using the Tools menu

Press TOOLS to display the following options when viewing a TV programme.

Options	Description
Close	Closes the Tools menu.
Picture Mode	See page 28.
Sound Mode	See page 30.
Motion Enhancer	See page 34.
Speaker	See page 36.
PAP	See page 22.
Audio Language (in digital mode only)	See page 44.
Subtitle Setting (in digital mode only)	See page 43.
Digital Favourites (in digital mode only)	See page 19.
$\text{V}$ Volume	See page 36.
Sleep Timer	See page 37.
Power Saving	See page 38.
Auto Clock Set (in analogue mode only)	Allows you to switch to digital mode and obtain the time.
System Information (in digital mode only)	Displays the system information screen.



































# Using the Digital Electronic Programme Guide (EPG) DV3\*



- 1 In digital mode, press .
- 2 Perform the desired operation as shown in the following table or displayed on the screen.

## Digital Electronic Programme Guide (EPG)

\* This function may not be available in some countries/regions.

To	Do this
Watch a programme	Press  /  /  /  to select the programme, then press  .
Turn off the EPG	Press  .
Sort the programme information by category – Category list	<ol style="list-style-type: none"> <li>1 Press the blue button.</li> <li>2 Press / to select a category, then press .</li> </ol> <p>The categories available include:  <b>“All Categories”</b>, <b>“Radio”</b>: Contains all available channels.  <b>Other category name (e.g. “News”)</b>: Contains all programmes corresponding to the selected category.</p>
Set a programme to be recorded – Timer REC	<ol style="list-style-type: none"> <li>1 Press /// to select the programme you want to record, then press .</li> <li>2 Press / to select “Timer REC”.</li> <li>3 Press  to set the TV and your VCR timers.</li> </ol> <p>A red  symbol appears by that programme’s information. The  indicator on the TV front panel lights up in orange.</p> <p> The above procedure can be used even if the programme to be recorded has already started.</p>
Set a programme to be displayed automatically on the screen when it starts – Reminder	<ol style="list-style-type: none"> <li>1 Press /// to select the future programme you want to display, then press /.</li> <li>2 Press / to select “Reminder”, then press .</li> </ol> <p>A  symbol appears by that programme’s information. The  indicator on the TV front panel lights up in orange.</p> <p> If you switch the TV to standby mode, it will automatically turn itself on when the programme is about to start.</p>

*Continued*

To	Do this
Set the time and date of a programme you want to record – Manual timer REC	<ol style="list-style-type: none"> <li>1 Press <b>⊕/?</b>.</li> <li>2 Press <b>⬆/⬇</b> to select “Manual timer REC”, then press <b>⊕</b>.</li> <li>3 Press <b>⬆/⬇</b> to select the date, then press <b>⬅</b>.</li> <li>4 Set the start and stop time in the same way as in step 3.</li> <li>5 Press <b>⬆/⬇</b> to select the programme, then press <b>⊕</b>.</li> <li>6 Press <b>⊕</b> to set the TV and your VCR timers. The <b>⌚</b> indicator on the TV front panel lights up in orange.</li> </ol>
Cancel a recording/reminder – Timer list	<ol style="list-style-type: none"> <li>1 Press <b>⊕/?</b>.</li> <li>2 Press <b>⬆/⬇</b> to select “Timer list”, then press <b>⊕</b>.</li> <li>3 Press <b>⬆/⬇</b> to select the programme you want to cancel, then press <b>⊕</b>.</li> <li>4 Press <b>⬆/⬇</b> to select “Cancel Timer”, then press <b>⊕</b>. A display appears to confirm that you want to cancel the programme.</li> <li>5 Press <b>⬅/➡</b> to select “Yes”, then press <b>⊕</b> to confirm.</li> </ol>



- You can set VCR timer recording on the TV only for SmartLink compatible VCRs. If your VCR is not SmartLink compatible, a message will be displayed to remind you to set your VCR timer.
- Once a recording has begun, you can switch the TV to standby mode, but do not turn off the TV completely or the recording may be cancelled.
- If an age restriction for programmes has been selected, a message asking for a PIN code will appear on the screen. For details, see “Parental Lock” on page 44.

# Using the Digital Favourite list **DVB\***



Digital Favourite list

\* This function may not be available in some countries/regions.

The Favourite feature allows you to specify up to four lists of your favourite programmes.









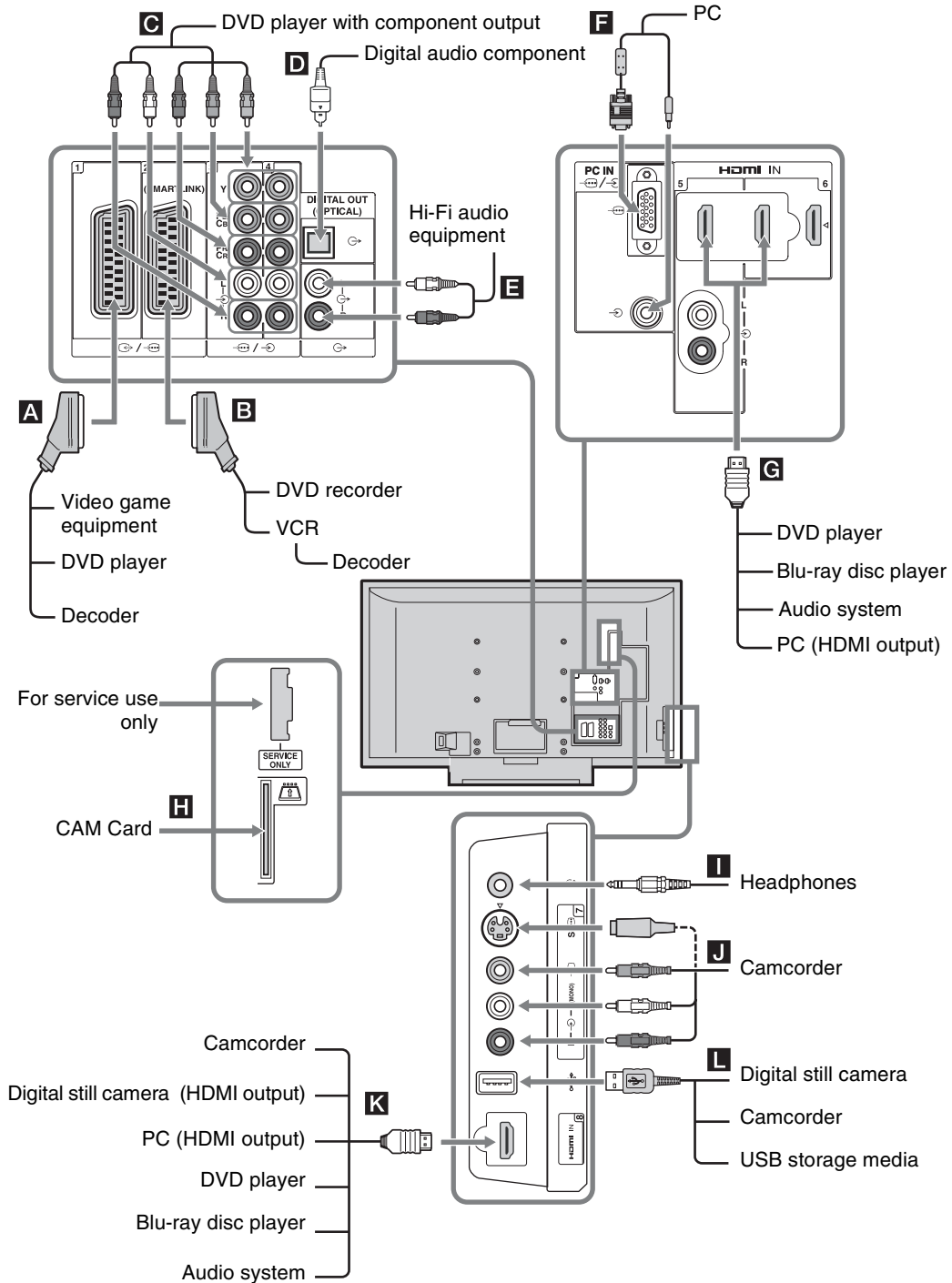



















- 1** Press MENU.
- 2** Press  $\uparrow/\downarrow$  to select “Digital Favourites”, then press  $\oplus$ .
- 3** Perform the desired operation as shown in the following table or displayed on the screen.

To	Do this
Create your Favourite list for the first time	<ol style="list-style-type: none"> <li><b>1</b> Press <math>\oplus</math> to select “Yes”.</li> <li><b>2</b> Press the yellow button to select the Favourite list.</li> <li><b>3</b> Press <math>\uparrow/\downarrow</math> to select the channel you want to add, then press <math>\oplus</math>. Channels that are stored in the Favourite list are indicated by a <math>\heartsuit</math> symbol.</li> </ol>
Watch a channel	<ol style="list-style-type: none"> <li><b>1</b> Press the yellow button to navigate through your Favourite lists.</li> <li><b>2</b> Press <math>\oplus</math> while selecting a channel.</li> </ol>
Turn off the Favourite list	Press RETURN.
Add or remove channels in the currently edited Favourite list	<ol style="list-style-type: none"> <li><b>1</b> Press the blue button.</li> <li><b>2</b> Press the yellow button to select the Favourite list you want to edit.</li> <li><b>3</b> Press <math>\uparrow/\downarrow</math> to select the channel you want to add or remove, then press <math>\oplus</math>.</li> </ol>
Remove all channels from the current Favourite list	<ol style="list-style-type: none"> <li><b>1</b> Press the blue button.</li> <li><b>2</b> Press the yellow button to select the Favourite list you want to edit.</li> <li><b>3</b> Press the blue button.</li> <li><b>4</b> Press <math>\leftarrow/\rightarrow</math> to select “Yes”, then press <math>\oplus</math> to confirm.</li> </ol>

# Connecting optional equipment

You can connect a wide range of optional equipment to your TV.



Connect to	Input symbol on screen	Description
<b>A</b> 	 AV1 or  AV1	When you connect the decoder, the scrambled signal from the TV tuner is output to the decoder, then the unscrambled signal is output from the decoder.
<b>B</b> 	 AV2 or  AV2	SmartLink is a direct link between the TV and a VCR/DVD recorder.
<b>C</b>  /  3 or  /  4	 AV3 or  AV4	
<b>D</b> DIGITAL OUT (OPTICAL)		Use an Optical audio cable.
<b>E</b> 		You can listen to the sound from the TV on Hi-Fi audio equipment.
<b>F</b> PC IN 	PC	It is recommended to use the supplied PC cable with ferrite cores.
<b>G</b> HDMI IN 5 or 6 <b>K</b> HDMI IN 8	 AV5,  AV6 or  AV8	<p>The digital video and audio signals are input from the equipment.</p> <p>In addition, when HDMI control compatible equipment is connected, communication with the connected equipment is supported. Refer to page 38 to set up this communication.</p> <p>If the equipment has a DVI socket, connect the DVI socket to the HDMI IN 5 socket through a DVI - HDMI adaptor interface (not supplied), and connect the equipment's audio out sockets to the audio in the HDMI IN 5 sockets.</p> <p></p> <ul style="list-style-type: none"> <li>• The HDMI sockets only support the following video inputs: 480i, 480p, 576i, 576p, 720p, 1080i, 1080p and 1080/24p. For PC video inputs, see page 47.</li> <li>• Be sure to use only an HDMI cable that bears the HDMI logo.</li> <li>• When connecting an HDMI control compatible audio system, be sure to also connect to the DIGITAL OUT (OPTICAL) socket.</li> </ul>
<b>H</b>  CAM (Conditional Access Module)		<p>To use pay TV services. For details, refer to the instruction manual supplied with your CAM.</p> <p>To use the CAM, remove the “dummy” card from the CAM slot. Turn off the TV when inserting your CAM into the CAM slot. When you do not use the CAM, we recommend that the “dummy” card be inserted and kept in the CAM slot.</p> <p></p> <p>CAM is not supported in some countries/regions. Check with your authorized dealer.</p>
<b>I</b> Headphones		You can listen to sound from the TV on headphones.
<b>J</b> S  7 or  7, and  7	 AV7 or  AV7	To avoid picture noise, do not connect the camcorder to the video  7 socket and the S video  7 socket at the same time. If you connect mono equipment, connect to the  7 L socket.
<b>L</b>  USB		You can view photographs on a Sony digital still camera, camcorder or USB storage media connected to the TV. For details, see page 26.

# Viewing pictures from the connected equipment

Turn on the connected equipment, then perform one of the following operation.

## For equipment connected to the scart sockets using a fully-wired 21-pin scart lead (page 20)

Start playback on the connected equipment.

The picture from the connected equipment appears on the screen.

## For an auto-tuned VCR (page 7)

In analogue mode, press PROG +/-, or the number buttons, to select the video channel.

## For other connected equipment (page 20)

Press / to display the connected equipment list. Press / to select the desired input source, then press . (The highlighted item is selected if 2 seconds pass without any operation after pressing / .)

When the input source is set to “Skip” in the “AV Preset” menu under the “Set-up” menu (page 37), that input does not appear in the list.

## Additional operations

To	Do this
Return to normal TV mode	Press DIGITAL/ANALOG.
Access the Input signal index table (except analogue mode)	Press  to access the Input signal index table. To select an input source, press / , then press .
Change the volume of the connected HDMI control compatible audio system	Press  +/-.
Mute the sound of the connected HDMI control compatible audio system	Press . Press again to restore.

## Using the Tools menu

Press TOOLS to display the following options when viewing pictures from connected equipment.

Options	Description
Close	Closes the Tools menu.
Picture Mode	See page 28.
Sound Mode	See page 30.
Motion Enhancer	See page 34.
Speaker	See page 36.
PAP (except PC input mode)	See page 22.
PIP (in PC input mode only)	See page 23.
Auto Adjustment (in PC input mode only)	See page 33.
Horizontal Shift (in PC input mode only)	See page 33.
Volume	See page 36.
Sleep Timer (except PC input mode)	See page 37.
Power Saving	See page 38.
Auto Clock Set	Allows you to switch to digital mode and obtain the time.

## To view two pictures simultaneously – PAP (Picture and Picture)

You can view two pictures (external input and TV programme) on the screen simultaneously. Connect the optional equipment (page 20), and make sure that images from the equipment appear on the screen (page 22).



- This function is not available for a PC input source.
- You cannot change the size of the pictures.

- 1 Press TOOLS to display the Tools menu.
- 2 Press / to select “PAP”, then press . The picture from connected equipment is displayed on the left and the TV programme is displayed on the right.
- 3 Press number buttons or PROG +/- to select the TV channel.  
**To return to single picture mode**  
Press or RETURN.



The picture framed in green is audible. You can switch the audible picture by pressing / .

## To view two pictures simultaneously – PIP (Picture in Picture)

You can view two pictures (PC input and TV programme) on the screen simultaneously. Connect a PC (page 20), and make sure that images from a PC appear on the screen.

- 1 Press TOOLS to display the Tools menu.
- 2 Press  $\uparrow/\downarrow$  to select “PIP”, then press  $\oplus$ .  
The picture from the connected PC is displayed with full size and the TV programme is displayed on the right corner.  
You can use  $\uparrow/\downarrow/\leftarrow/\rightarrow$  to move the TV programme screen position.

- 3 Press number buttons or PROG +/- to select the TV channel.

### To return to single picture mode

Press RETURN.



You can switch the audible picture by selecting “TV Sound / PC Sound” from the Tools menu.

# Using the remote

## Buttons for using optional equipment

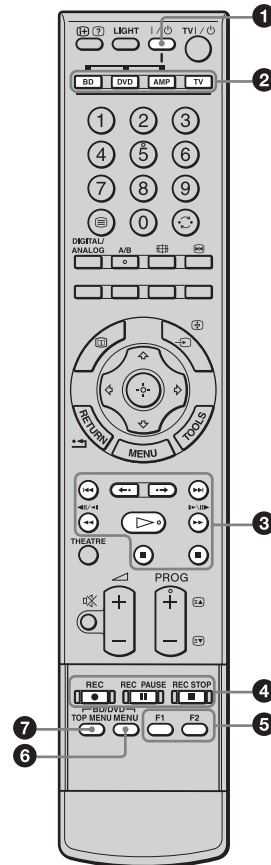

- 1 **I/⏻**  
Turns on or off the optional equipment selected from the function buttons.
- 2 **Function buttons**  
Enables you to operate the corresponding equipment. For details, see “Programming the remote” on page 24.
- 3 **BD/DVD operating buttons**
  - $\lll$  : Replays the current programme from the previous chapter mark (if any).
  - $\ggg$  : Advances forward to the next chapter mark (if any).
  - $\ll$  : Replays the current programme for a set period of time.
  - $\gg$  : Advances forward a set period of time.
  - $\lll$  : Plays a programme in fast reverse mode.
  - $\ggg$  : Plays a programme in fast forward mode.
  - $\triangleright$  : Plays a programme at a normal speed.
  - $\parallel$  : Pauses playback.
  - $\blacksquare$  : Stops the playback.

*Continued*

#### 4 DVD record buttons

- REC: Starts recording.
- REC PAUSE: Pauses the recording.
- REC STOP: Stops the recording.

#### 5 F1/F2

- Selects a disc when using a DVD changer.
- Selects a function when using a combination unit (e.g. a BD/DVD).

For details, see the operating instructions supplied with the DVD changer or combination unit.

#### 6 BD/DVD MENU

Displays the DVD disc menu. For details, see the operating instructions supplied with the connected equipment.

#### 7 BD/DVD TOP MENU

Displays the top menu of the DVD disc. For details, see the operating instructions supplied with the connected equipment.



The ▷ button has a tactile dot. Use the tactile dot as a reference when operating other equipment.

## Programming the remote

This remote is preset to operate Sony TVs, most Sony BDs, DVDs and AMPs (Home Theatre, etc.). To control BDs and DVDs of other manufacturers (and some other Sony BD, DVD and AMP models), do the following procedure to programme the remote.



Before you start, look up the three-digit code for your brand of BD, DVD or AMP from the “Manufacturer’s codes” on page 24.

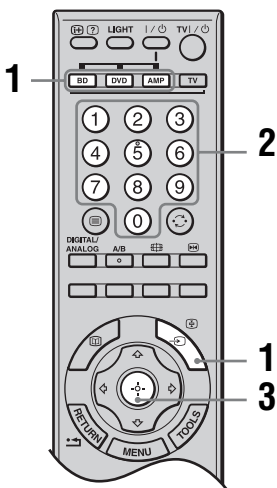

1 Press and hold the BD, DVD or AMP function button you want to programme on the remote, then press /☑, keeping the function button pressed down.

The selected function button (BD, DVD or AMP) will flash.

2 Press the number buttons to enter the three-digit manufacturer’s code number when the button flashes.

If code is not entered within 10 seconds, you must perform the step 1 again.

3 Press .

When the programming is correct, the selected function button will flash twice, and when not, it will flash five times.

4 Turn on your equipment and check that the following main functions work.

▷ (playback), ■ (stop), ◀◀ (rewind), ▶▶ (fast forward), channel selection for both BDs and DVDs, TOP MENU/MENU and ↕/↔/↔/↔ only for DVDs.

**If your equipment is not working, or some of the functions do not work**

Enter the correct code or try the next code listed for the brand. However, not all models of every brand may be covered.

**To return to normal TV operation**

Press the TV function button.

## Manufacturer’s codes

### DVD brand list

DVD Player

Brand	Code
SONY	001, 029, 030, 036 – 044, 053 – 055
AIWA	021
AKAI	032
DENON	018, 027, 020, 002
GRUNDIG	009, 028, 023, 024, 016, 003
HITACHI	025, 026, 015, 004, 035
JVC	006, 017
KENWOOD	008
LG	015, 014, 034
LOEWE	009, 028, 023, 024, 016, 003
MATSUI	013, 016
ONKYO	022, 033
PANASONIC	018, 027, 020, 002, 045 – 047



Brand	Code
PHILIPS	009, 028, 023, 024, 016, 003, 031
PIONEER	004, 050, 051, 052
SAMSUNG	011, 014
SANYO	007
SHARP	019, 027
THOMSON	012
TOSHIBA	003, 048, 049
YAMAHA	018, 027, 020, 002

#### BD (Blu-ray Disc) Player

Brand	Code
SONY	101 – 103

#### DVD/VCR Player

Brand	Code
SONY	251

#### DVD recorder

Brand	Code
SONY	201 – 203

#### VCR brand list

Brand	Code
SONY	301 – 310, 362
AIWA	325, 331, 351
AKAI	326, 329, 330
DAEWOO	342, 343
GRUNDIG	358, 355, 360, 361, 320, 351, 366
HITACHI	327, 333, 334
JVC	314, 315, 322, 344, 352 – 354, 348, 349
LG	332, 338
LOEWE	358, 355, 360, 361, 320, 351
MATSUI	356, 357
ORION	328
PANASONIC	321, 323
PHILIPS	311 – 313, 316 – 318, 358, 359, 363, 364
SAMSUNG	339 – 341, 345
SANYO	335, 336

Brand	Code
SHARP	324
THOMSON	319, 350, 365
TOSHIBA	337

#### AUX Sony systems brand list

##### DAV Home Theatre System

Brand	Code
SONY (DAV)	401 – 404

#### AV receiver

Brand	Code
SONY	451 – 454

#### Digital terrestrial receiver

Brand	Code
SONY	501 – 503

# Using USB photo viewer

You can view photographs (in JPEG format) stored in a Sony digital still camera, camcorder or USB storage media on your TV.

- 1 Connect a supported USB device to the TV.
- 2 Press MENU.
- 3 Press  $\uparrow/\downarrow$  to select "Photo", then press  $\oplus$ . The thumbnail screen appears.
- 4 Press  $\uparrow/\downarrow/\leftarrow/\rightarrow$  to select the photograph or folder you want to view, and then press  $\oplus$ .  
If you want to view a slide show, press  $\leftarrow/\rightarrow$  to select "Slide Show", then press  $\oplus$ .

## Advanced operations

Press  $\leftarrow/\rightarrow$  to select an option, then press  $\oplus$ .

Options	Description
Device Selection	Select the device if multiple devices are connected.
Picture Settings	You can make "Backlight" (page 28), "Contrast" (page 28) and "Colour Temperature" settings.
Set-up	You can make advanced settings for the slide show and set the display sequence for the thumbnails.



- USB photo viewer only supports DCF-compliant JPEG photographs.
- Set the camera's USB connection mode to Auto or "Mass Storage" mode when you are connecting Sony digital still camera. For more information about USB connection mode, see the instructions supplied with the device that you use.
- Do not turn off the TV or connected USB device, or disconnect the USB cable or remove the recording media while the data on the recording media is being accessed. The data on the recording media may be damaged.
- Using unsupported USB device is not guaranteed and may cause malfunctions.
- Sony cannot be held liable for any damage to or loss of data on the recording media due to a malfunction of any connected devices or the TV.
- Check the website below for the up to date information about compatible USB devices.  
<http://support.sony-europe.com/TV/compatibility/>

# Using HDMI control

The HDMI control function allows equipment to control each other using HDMI CEC (Consumer Electronics Control) specified by HDMI.

You can connect Sony HDMI control compatible equipment such as TVs, hard disk DVD recorders and audio systems (with HDMI cables) to let them work integratedly.

Be sure to correctly connect and set the compatible equipment to use the HDMI control function.

## To connect the HDMI control compatible equipment

Connect the compatible equipment and the TV with an HDMI cable. When connecting an audio system, in addition to the HDMI cable, be sure to also connect the DIGITAL OUT (OPTICAL) socket of the TV and the audio system using an optical audio cable. For details, see page 20.

## To make the HDMI control settings

HDMI control must be set on both the TV side and the connected equipment side. See "HDMI Set-up" on page 38 for the TV side settings. See the operating instructions of the connected equipment for setting details.

## HDMI control functions

- Turns the connected equipment automatically off when you turn the TV off.
- Turns the TV on and automatically switches the input to the connected equipment when the equipment starts to play.
- If you turn on a connected audio system while the TV is on, the sound output switches from the TV speaker to the audio system.
- Adjusts the volume and mutes the sound of a connected audio system.

## Using Menu Functions

# Navigating through menus

Menu functions allow you to enjoy various convenient features of this TV. You can easily select channels or inputs sources and change the settings for your TV.

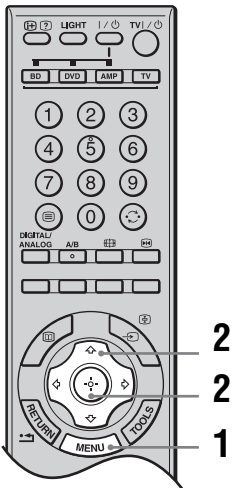

- 1 Press MENU.
- 2 Press  $\uparrow/\downarrow$  to select an option, then press  $\oplus$ .  
To exit the menu, press MENU.

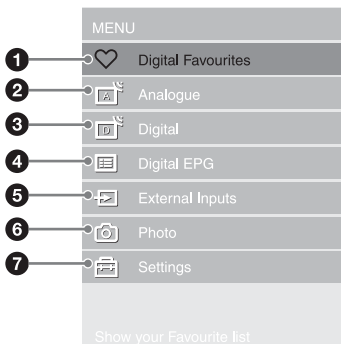

- 1 **Digital Favourites\***  
Displays the Favourite list (page 19).
- 2 **Analogue**  
Returns to the last viewed analogue channel.
- 3 **Digital\***  
Returns to the last viewed digital channel.

#### 4 **Digital EPG\***

Displays the Digital Electronic Programme Guide (EPG) (page 17).

#### 5 **External Inputs**

Selects equipment connected to your TV.

- To watch the desired external input, select the input source, then press  $\oplus$ .
- To assign a label to an external input, select “Edit AV Labels” (page 37).
- To select the connected HDMI control compatible equipment, select “HDMI Device Selection”.

#### 6 **Photo**

The thumbnail screen appears (page 26).

#### 7 **Settings**

Displays the “Settings” menu where most of the advanced settings and adjustments are performed.

1 Press  $\uparrow/\downarrow$  to select a menu icon, then press  $\oplus$ .

2 Press  $\uparrow/\downarrow/\leftarrow/\rightarrow$  to select an option or adjust a setting, then press  $\oplus$ .

For details about settings, see pages 28 to 45.



The options you can adjust vary depending on the situation. Unavailable options are greyed out or not displayed.

\* This function may not be available in some countries/regions.

# Picture menu

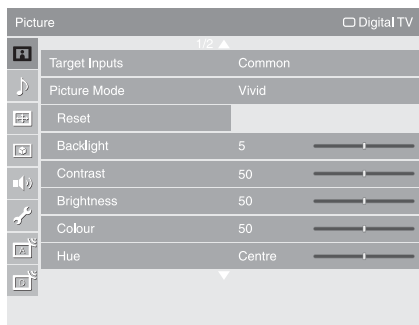

You can select the options listed below on the “Picture” menu. To select options in “Settings”, refer to “Navigating through menus” (page 27).

## Target Inputs

For the input currently being viewed, select whether to use the common setting or to set each item separately.

**“Common”:** Applies common settings whose adjustments are shared with other inputs in which “Target Inputs” is set to “Common”.

**Current input name (e.g. AV1):** Allows you to set each option separately for the current input.



Set each input to “Common” if you require the same settings to apply to each input.

## Picture Mode

Selects the picture mode. The options for “Picture Mode” may differ depending on the “Video/Photo” setting (page 34).

**“Vivid”:** For enhanced picture contrast and sharpness.

**“Standard”:** For standard picture. Recommended for home entertainment.

**“Cinema”:** For viewing film-based content. Most suitable for viewing in a theatre-like environment.

**“Photo”:** Sets the optimum picture quality for photographs.

**“Custom”:** Allows you to store your preferred settings.

## Reset

Resets all the “Picture” settings except “Target Inputs”, “Picture Mode” and “Advanced Settings” to the factory settings.

## Backlight

Adjusts the brightness of the backlight.

## Contrast

Increases or decreases picture contrast.

## Brightness

Brightens or darkens the picture.

## Colour

Increases or decreases colour intensity.

## Hue

Increases or decreases the green tones and red tones.



“Hue” can only be adjusted for an NTSC colour signal (e.g. U.S.A. video tapes).

<b>Colour Temperature</b>	<p>Adjusts the whiteness of the picture.</p> <p><b>“Cool”</b>: Gives the white colours a blue tint.</p> <p><b>“Neutral”</b>: Gives the white colours a neutral tint.</p> <p><b>“Warm 1”/“Warm 2”</b>: Gives the white colours a red tint. “Warm 2” gives a redder tint than “Warm 1”.</p> <p></p> <p>“Warm 1” and “Warm 2” are not available when “Picture Mode” is set to “Vivid”.</p>
<b>Sharpness</b>	Sharpens or softens the picture.
<b>Noise Reduction</b>	<p>Reduces the picture noise (snowy picture) in a weak broadcast signal.</p> <p><b>“Auto”</b>: Automatically reduces the picture noise (in analogue TV mode or composite signals only).</p> <p><b>“High”/“Medium”/“Low”</b>: Modifies the effect of the noise reduction.</p> <p><b>“Off”</b>: Turns off the “Noise Reduction” feature.</p>
<b>MPEG Noise Reduction</b>	Reduces the picture noise in MPEG-compressed video.
<b>DRC Mode</b>	<p>Produces a high-resolution picture for high-density sources (e.g., Blu-ray disc player, DVD player, satellite receiver).</p> <p><b>“Mode 1”</b>: Recommended mode.</p> <p><b>“Mode 2”</b>: Only available for 1080i format. “Mode 2” is especially effective when original standard-definition signals have been up-converted to 1080i format.</p> <p><b>“Off”</b>: Turns off the “DRC Mode” feature.</p>
<b>DRC Palette</b>	<p>Customizes the level of detail (“Reality”) and smoothness (“Clarity”) for each input signal. For example, you can create a custom setting for your cable input’s picture, and create another for your DVD player’s pictures.</p> <p>The “DRC Palette” appears. Press <math>\uparrow/\downarrow/\leftarrow/\rightarrow</math> to adjust the position of the marker (●). As you move the ● higher along the “Reality” axis, the picture becomes more detailed. As you move the ● to the right along the “Clarity” axis, the picture becomes smoother.</p>
<b>Advanced Settings</b>	<p>Customizes the Picture function in more detail. When you set “Picture Mode” to “Vivid”, you cannot set/change these settings.</p> <p><b>“Reset”</b>: Resets all the advanced settings to the factory settings.</p> <p><b>“Black Corrector”</b>: Enhances black areas of the picture for stronger contrast.</p> <p><b>“Adv. Contrast Enhancer”</b>: Automatically adjusts “Backlight” and “Contrast” to the most suitable settings judging from the brightness of the screen. This setting is especially effective for dark images scenes. It will increase the contrast distinction of the darker picture scenes.</p> <p><b>“Gamma”</b>: Adjusts the balance between bright and dark areas of the picture.</p> <p><b>“Clear White”</b>: Emphasizes white colours.</p> <p><b>“Colour Space”</b>: Changes the colour reproduction gamut. “Wide” reproduces the vivid colour and “Standard” reproduces the standard colour.</p> <p><b>“Live Colour”</b>: Makes colours more vivid.</p> <p><b>“White Balance”</b>: Adjusts the colour temperature colour by colour.</p> <p><b>“Detail Enhancer”</b>: Enhances the details of the picture.</p> <p><b>“Edge Enhancer”</b>: Enhances the outline of the picture.</p>

# Sound menu

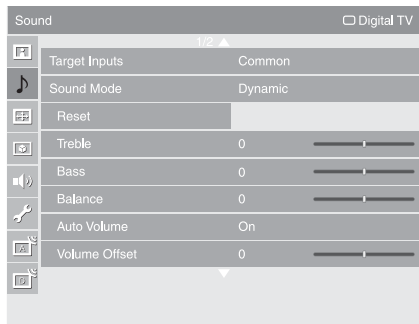

You can select the options listed below on the “Sound” menu. To select options in “Settings”, refer to “Navigating through menus” (page 27).

## Target Inputs

For the input currently being viewed, select whether to use the common setting or to set each item separately.

**“Common”**: Applies common settings whose adjustments are shared with other inputs in which “Target Inputs” is set to “Common”.

**Current input name (e.g. AV1)**: Allows you to set each option separately for the current input.



Set each input to “Common” if you require the same settings to apply to each input.

## Sound Mode

**“Dynamic”**: Enhances treble and bass.

**“Standard”**: For standard sound. Recommended for home entertainment.

**“Custom”**: Flat response. Also allows you to store your preferred settings.

## Reset

Resets all the “Sound” settings except “Target Inputs”, “Sound Mode” and “Dual Sound” to the factory settings.

## Treble

Adjusts higher-pitched sounds.

## Bass

Adjusts lower-pitched sounds.

## Balance

Emphasizes left or right speaker balance.

## Auto Volume

Keeps a constant volume level even when volume level gaps occur (e.g. adverts tend to be louder than programmes).

## Volume Offset

Adjusts the volume level of the current input relative to other inputs, when “Target Inputs” is set to the current input name (e.g. AV1).

## Surround

**“S-FORCE Front Surround”**: Available for normal stereo broadcast and 5.1ch digital broadcast surround audio, and the audio input from connected equipment.

**“Off”**: Converts and reproduces 5.1ch and other digital broadcast surround audio as normal stereo audio (2ch). Reproduces the original audio of other broadcasts as is.

---

**Voice Zoom**

Adjusts the clarity of human voices. For example, if the voice of a news announcer is indistinct, you can turn up this setting to make the voice clearer. Conversely, if you are watching a sports programme, you can turn down this setting to soften the voice of the commentator.

---

**Sound Booster**

Gives sound more impact by compensating for phase effects in speakers.

---

**Dual Sound**

Selects the sound from the speaker for a stereo or bilingual broadcast.

**“Stereo”/“Mono”**: For a stereo broadcast.

**“A”/“B”/“Mono”**: For a bilingual broadcast, select “A” for sound channel 1, “B” for sound channel 2, or “Mono” for a mono channel, if available.



If you select other equipment connected to the TV, set “Dual Sound” to “Stereo”, “A” or “B”. However, when the external equipment connected to the HDMI socket is selected, this is fixed to “Stereo” (except when using the audio in sockets).

---

# Screen menu (except for PC input)

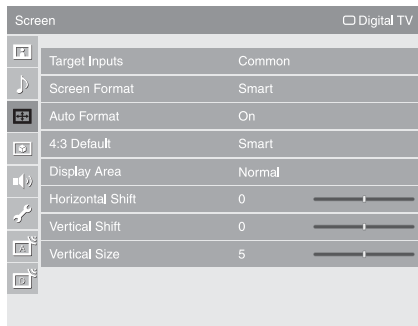

You can select the options listed below on the “Screen” menu. To select options in “Settings”, refer to “Navigating through menus” (page 27).

## Target Inputs

For the input currently being viewed, select whether to use the common setting or to set each item separately.

**“Common”**: Applies common settings whose adjustments are shared with other inputs in which “Target Inputs” is set to “Common”.

**Current input name (e.g. AV1)**: Allows you to set each option separately for the current input.



Set each input to “Common” if you require the same settings to apply to each input.

## Screen Format

For details about the screen format, see “To change the screen format manually to suit the broadcast” on page 16.

## Auto Format

Automatically changes the screen format according to the broadcast signal. To keep your setting, select “Off”.



Even if “Auto Format” is set to “On” or “Off”, you can always modify the format of the screen by pressing **⏏** repeatedly.

## 4:3 Default

Selects the default screen format for use with 4:3 broadcasts.

**“Smart”**: Displays conventional 4:3 broadcasts with an imitation wide screen effect.

**“4:3”**: Displays conventional 4:3 broadcasts in the correct proportions.

**“Off”**: Keeps the current “Screen Format” setting when the channel or input is changed.

## Display Area

Adjusts the screen area for displaying the picture.

**“Full Pixel”**: Displays the picture for 1080i or 1080p sources in the original size when parts of the picture are cut off.

**“+1”**: Displays the original picture area. This setting can be selected for HDMI video input signals, except for 1080i or 1080p signals.

**“Normal”**: Displays the recommended picture area.

**“-1”/“-2”**: Enlarges the picture to hide the edge of the picture.

## Horizontal Shift

Adjusts the horizontal position of the picture.

## Vertical Shift

Adjusts the vertical position of the picture when “Screen Format” is set to “Smart”, “Zoom” or “14:9”.

## Vertical Size

Adjusts the vertical size of the picture when “Screen Format” is set to “Smart”.



# Screen menu (for PC input)

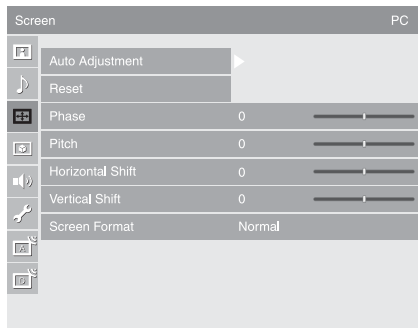

When you select the PC input, you can select the options listed below on the “Screen” menu. To select options in “Settings”, refer to “Navigating through menus” (page 27).

## Auto Adjustment

Automatically adjusts the display position, phase and pitch of the picture when the TV receives an input signal from the connected PC.



“Auto Adjustment” may not work well with certain input signals. In such cases, manually adjust “Phase”, “Pitch”, “Horizontal Shift” and “Vertical Shift”.

## Reset

Resets the PC screen settings to the factory settings.

## Phase

Adjusts the phase when the screen flickers.

## Pitch

Adjusts the pitch when the picture has unwanted vertical stripes.

## Horizontal Shift

Adjusts the horizontal position of the picture.

## Vertical Shift

Adjusts the vertical position of the picture.

## Screen Format

Selects a screen format for displaying input from your PC.

“**Normal**”: Displays the picture in its original size.

“**Full 1**”: Enlarges the picture to fill the vertical display area, keeping its original horizontal-to-vertical aspect ratio.

“**Full 2**”: Enlarges the picture to fill the display area.

# Video Settings menu

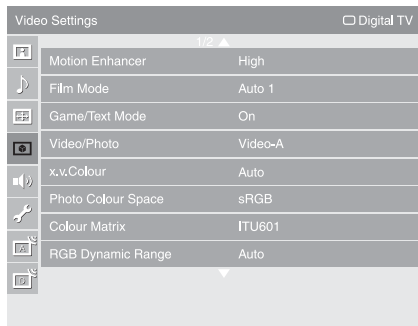

You can select the options listed below on the “Video Settings” menu. To select options in “Settings”, refer to “Navigating through menus” (page 27).

## Motion Enhancer

Provides smoother picture movement and reduces picture blur.

“**High**”: Provides smoother picture movement such as for film-based contents.

“**Standard**”: Provides smooth picture movement. Use this setting for standard use.

“**Off**”: Use this setting when the “High” and “Standard” settings result in noise.



Depending on the video, you may not see the effect visually, even if you have changed the setting.

## Film Mode

Provides improved picture movement when playing DVD or VCR images taken on film, reducing picture blur and graininess.

“**Auto 1**”: Provides smoother picture movement than the original film-based content. Use this setting for standard use.

“**Auto 2**”: Provides the original film-based content as is.

“**Off**”: Turns off the “Film Mode” feature.



If the image contains irregular signals or too much noise, “Film Mode” will be automatically turned off even if “Auto 1” or “Auto 2” is selected.

## Game/Text Mode

Provides the optimum screen for viewing images with fine lines and characters that are input from video game equipment and PCs. Set to “On” for the sharp display of fine lines or characters.

## Video/Photo

Provides suitable image quality by selecting the option depending on the input source (video or photograph data).

“**Video-A**”: Sets suitable image quality, depending on the input source, video data or photograph data when directly connecting Sony HDMI output-capable equipment that supports “Video-A” mode.

“**Video**”: Produces suitable image quality for moving pictures.

“**Photo**”: Produces suitable image quality for still images.



The setting is fixed to “Video” when Video-A mode is not supported on the connected equipment, even if “Video-A” is selected.

## x.v.Colour

Displays moving pictures that is more faithful to the original source by matching the colour space of source.



The setting is fixed to “Normal” when the input signal is HDMI (RGB), even if “x.v.Colour” is selected.

---

<b>Photo Colour Space</b>	<p>Selects the option to match the output colour space within the output signal from the equipment connected to the HDMI or component input jacks. Select “sYCC” when using the equipment that supports “x.v.Colour”.</p> <p> The setting is fixed to “sRGB” when the input signal is HDMI (RGB), even if “sYCC” is selected.</p>
<b>Colour Matrix</b>	<p>Usually used in the factory setting (AV1/2/7 (Composite and S video input signal) is set to “ITU601”, and AV3/4/5/6/8 (Component input signal) is set to “Auto”). If the colour tone of the picture from the input source does not match the colour standard and looks unnatural, select either “ITU601” or “ITU709”, which normalizes the colour tone.</p>
<b>RGB Dynamic Range</b>	<p>Produces natural colour by changing the luminance tone reproduction of HDMI input colour signals (RGB). Set to “Auto” for standard use. Change the settings only when the luminance tone of the display is unnatural.</p>
<b>Colour System</b>	<p>Selects the colour system (“Auto”, “PAL”, “SECAM”, “NTSC3.58” or “NTSC4.43”) according to the input signal from the input source.</p>

---

---

# Audio Settings menu

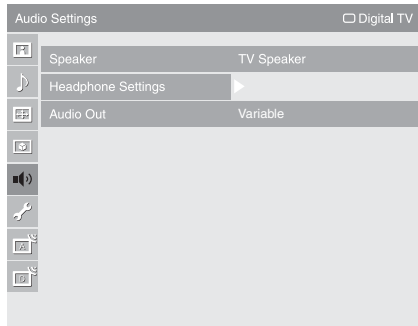

You can select the options listed below on the “Audio Settings” menu. To select options in “Settings”, refer to “Navigating through menus” (page 27).

---

## Speaker

Turns on/off the TV’s internal speakers.

“**TV Speaker**”: The TV speakers are turned on in order to listen to the TV’s sound through the TV speakers.

“**Audio System**”: The TV speakers are turned off in order to listen to the TV’s sound only through your external audio equipment connected to the audio output sockets. When HDMI control compatible equipment is connected, you can turn on the equipment whose operations are linked to the TV. This setting must be made after connecting the equipment.

---

## Headphone Settings

### **Speaker Link**

Switches the TV’s internal speakers on/off when headphones are connected.

“**On**”: Sound is output only from headphones.

“**Off**”: Sound is output from both the TV and headphones.

### **Volume**

Adjusts the volume of the headphones when “ Speaker Link” is set to “Off”.

### **Dual Sound**

Selects the sound from the headphone for a stereo or bilingual broadcast.

---

## Audio Out

“**Variable**”: The audio output from your audio system can be controlled by the TV’s remote.

“**Fixed**”: The audio output of the TV is fixed. Use your audio receiver’s volume control to adjust the volume (and other audio settings) through your audio system.

---

# Set-up menu

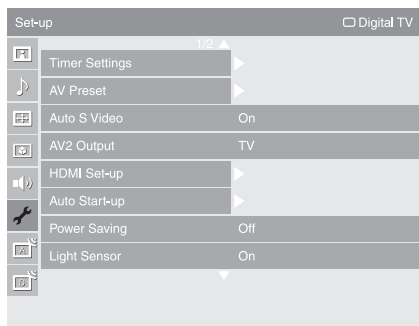

You can select the options listed below on the “Set-up” menu. To select options in “Settings”, refer to “Navigating through menus” (page 27).

## Timer Settings

Sets the timer to turn on/off the TV.

### Sleep Timer

Sets a period of time after which the TV automatically switches itself into standby mode.

When “Sleep Timer” is activated, the ⏰ (Timer) indicator on the TV front panel lights up in orange.



- If you turn off the TV and turn it on again, “Sleep Timer” is reset to “Off”.
- A notification message appears on the screen one minute before the TV switches to standby mode.

### On Timer

Sets the timer to turn on the TV from standby mode.

“**Day**”: Selects the day on which you want to activate the “On Timer”.

“**Time**”: Sets the time to turn on the TV.

“**Duration**”: Selects the time period after which the TV automatically switches to standby mode again.

“**Volume Set-up**”: Sets the volume for when the timer turns on the TV.

### Clock Set

Allows you to adjust the clock manually. When the TV is receiving digital channels, the clock cannot be adjusted manually since it is set to the time code of the broadcast signal.

## AV Preset

Assigns a name to any equipment connected to the side and rear sockets. The name will be displayed briefly on the screen when the equipment is selected. You can skip input signals from connected equipment that you do not want displayed on the screen.

1 Press  $\uparrow/\downarrow$  to select the desired input source, then press  $\oplus$ .

2 Press  $\uparrow/\downarrow$  to select the desired option below, then press  $\oplus$ .

**Equipment labels:** Uses one of the preset labels to assign a name to connected equipment.

“**Edit**”: Creates your own label. Follow steps 2 to 4 of “Programme Labels” (page 40).

“**Skip**”: Skips an unnecessary input source.



## Auto S Video

Selects the input signal from S video sockets S- $\rightarrow$ 7 when S- $\rightarrow$ 7/- $\rightarrow$ 7 sockets are both connected.

Continued

---



## AV2 Output

Sets a signal to be output through the socket labelled  on the rear of the TV. If you connect a VCR or other recording equipment to the  socket, you can then record from the equipment connected to other sockets of the TV.

“**TV**”: Outputs a broadcast.

“**AV1**”: Outputs signals from equipment connected to the  socket.

“**AV7**”: Outputs signals from equipment connected to the  socket.

“**Auto**”: Outputs whatever is being viewed on the screen (except signals from the , , HDMI IN 5, HDMI IN 6, HDMI IN 8 and PC IN  sockets).

---

## HDMI Set-up

This is used to set the HDMI control compatible equipment connected to the HDMI sockets. Note that the link setting must also be made on the side of the HDMI control compatible equipment that is connected.

### HDMI Control

Sets whether or not to link the operations of the HDMI control compatible equipment and the TV. When set to “On”, the following menu items can be performed.

#### Auto Devices Off

When this is set to “On”, any connected HDMI control compatible equipment will be turned off with the TV.

#### Auto TV On

When this is set to “On”, the TV turns on when any connected HDMI control compatible equipment is turned on.

#### HDMI Device List

Displays the connected HDMI control compatible equipment.



You cannot use “HDMI Control” if the TV operations are linked to the operations of an audio system that is compatible with HDMI control.

---

## Auto Start-up

Starts the initial set-up to select the language and country/region, and tune in all available digital and analogue channels.

Usually, you do not need to do this operation because the language and country/region will have been selected and channels already tuned when the TV was first installed (page 6).

However, this option allows you to repeat the process (e.g. to retune the TV after moving house, or to search for new channels that have been launched by broadcasters).

---

## Power Saving

Selects the power saving mode to reduce the power consumption of the TV.

When “Picture Off” is selected, the picture is switched off and the  (Picture Off) indicator on the TV front panel lights up in green. The sound remains unchanged.

---

## Light Sensor

“**On**”: Automatically optimises the picture settings according to the ambient light in the room.

“**Off**”: Turns off the “Light Sensor” feature.



Be sure not to put anything over the sensor, as its function may be affected. See page 14 for further information on the sensor.

---

## Logo Illumination

Lights up and turns off the Sony logo on the front of the TV.

---

## PC Power Management

Switches the TV to standby mode if no signal is received for 30 seconds in the PC input.

---

---

<b>Language</b>	Selects the language in which the menus are displayed.
<b>Product Information</b>	Displays your TV's product information.
<b>All Reset</b>	<p>Resets all settings to the factory settings and then displays the "Auto Start-up" screen.</p> <p></p> <ul style="list-style-type: none"><li>• Be sure not to turn the TV off during this period (it takes about 30 seconds) or press any buttons.</li><li>• All settings, including Digital Favourite list, country/region, language, auto tuned channels, etc. will be reset.</li></ul>

---

---

# Analogue Set-up menu

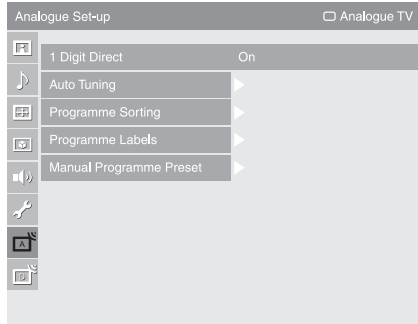

You can select the options listed below on the “Analogue Set-up” menu. To select options in “Settings”, refer to “Navigating through menus” (page 27).

---

## 1 Digit Direct

When “1 Digit Direct” is set to “On”, you can select an analogue channel using one preset number button (0 – 9) on the remote.



When “1 Digit Direct” is set to “On”, you cannot select channel numbers 10 and above entering two digits using the remote.

---

## Auto Tuning

Tunes in all the available analogue channels.

This option allows you to retune the TV after moving house, or to search for new channels that have been launched by broadcasters.

---

## Programme Sorting

Changes the order in which the analogue channels are stored on the TV.

- 1 Press  $\uparrow/\downarrow$  to select the channel you want to move to a new position, then press  $\oplus$ .
- 2 Press  $\uparrow/\downarrow$  to select the new position for your channel, then press  $\oplus$ .

---

## Programme Labels

Assigns a channel name of your choice up to five letters or numbers. The name will be displayed briefly on the screen when the channel is selected. (Names for channels are usually taken automatically from Analogue Text (if available).)

- 1 Press  $\uparrow/\downarrow$  to select the channel you want to name, then press  $\oplus$ .
- 2 Press  $\uparrow/\downarrow$  to select the desired letter or number (“\_” for a blank space), then press  $\Rightarrow$ .

### If you input a wrong character

Press  $\Leftarrow/\Rightarrow$  to select the wrong character. Then, press  $\uparrow/\downarrow$  to select the correct character.

### To delete all the characters

Select “Reset”, then press  $\oplus$ .

- 3 Repeat the procedure in step 2 until the name is completed.
- 4 Select “OK”, then press  $\oplus$ .



## Manual Programme Preset

Before selecting “Label”/“AFT”/“Audio Filter”/“Skip”/“Decoder”/“LNA”, press PROG +/- to select the programme number with the channel. You cannot select a programme number that is set to “Skip” (page 41).

### Programme/System/Channel

Presets programme channels manually.

- 1 Press  $\uparrow/\downarrow$  to select “Programme”, then press  $\oplus$ .
- 2 Press  $\uparrow/\downarrow$  to select the programme number you want to manually tune (if tuning a VCR, select channel 00), then press RETURN.
- 3 Press  $\uparrow/\downarrow$  to select “System”, then press  $\oplus$ .
- 4 Press  $\uparrow/\downarrow$  to select one of the following TV broadcast systems, then press RETURN.
  - B/G:** For western European countries/regions
  - I:** For the United Kingdom
  - D/K:** For eastern European countries/regions
  - L:** For France
- 5 Press  $\uparrow/\downarrow$  to select “Channel”, then press  $\oplus$ .
- 6 Press  $\uparrow/\downarrow$  to select “S” (for cable channels) or “C” (for terrestrial channels), then press  $\Rightarrow$ .



“S” is not available when “United Kingdom” is selected for “Country” (page 7).

- 7 Tune the channels as follows:

#### If you do not know the channel number (frequency)

Press  $\uparrow/\downarrow$  to search for the next available channel. When a channel has been found, the search will stop. To continue searching, press  $\uparrow/\downarrow$ .

#### If you know the channel number (frequency)

Press the number buttons to enter the channel number of the broadcast you want or your VCR channel number.

- 8 Press  $\oplus$  to jump to “Confirm”, then press  $\oplus$ .
- 9 Press  $\downarrow$  to select “OK”, then press  $\oplus$ .

Repeat the procedure above to preset other channels manually.

### Label

Assigns a name of your choice, up to five letters or numbers, to the selected channel. This name will be displayed briefly on the screen when the channel is selected. To input characters, follow steps 2 to 4 of “Programme Labels” (page 40).

### AFT

Allows you to fine-tune the selected programme number manually if you feel that a slight tuning adjustment will improve the picture quality.

You can adjust the fine tuning over a range of -15 to +15. When “On” is selected, the fine tuning is performed automatically.

### Audio Filter

Improves the sound for individual channels in the case of distortion in mono broadcasts. Sometimes a non-standard broadcast signal can cause sound distortion or intermittent sound muting when watching mono programmes.

If you do not experience any sound distortion, we recommend that you leave this option set to the factory setting “Off”.





You cannot receive stereo or dual sound when “Low” or “High” is selected.

### Skip

Skips unused analogue channels when you press PROG +/- to select channels. (You can still select a skipped channel using the number buttons.)

**Decoder**

Shows and records the scrambled channel selected when using a decoder connected directly to scart connector  1, or to scart connector  2 via a VCR.



This option is not available when “United Kingdom” is selected for “Country” (page 7).

**LNA**

Improves the picture quality for individual channels in the case of very weak broadcast signals (noisy picture).

If you cannot see any improvement in the picture quality even if you set to “On”, set this option to “Off” (factory setting).

**Confirm**

Saves changes made to the “Manual Programme Preset” settings.

---

# Digital Set-up menu DV3

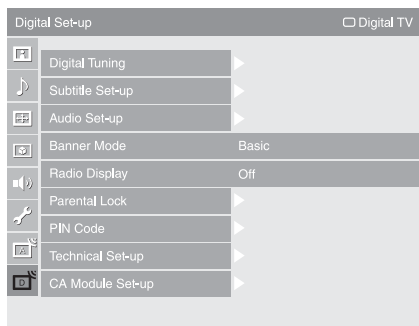

You can select the options listed below on the “Digital Set-up” menu. To select options in “Settings”, refer to “Navigating through menus” (page 27).



Some functions may not be available in some countries/regions.

## Digital Tuning

### Digital Auto Tuning

Tunes in the available digital channels.

This option allows you to retune the TV after moving house, or to search for new channels that have been launched by broadcasters. For details, see “Auto tuning the TV” on page 7.

### Programme List Edit

Removes any unwanted digital channels stored on the TV, and changes the order of the digital channels stored on the TV.

**1** Press  $\uparrow/\downarrow$  to select the channel you want to remove or move to a new position.

Press the number buttons to enter the known three-digit programme number of the broadcast you want.

**2** Remove or change the order of the digital channels as follows:

#### To remove the digital channel

Press  $\oplus$ . After a confirmation message appears, press  $\leftarrow$  to select “Yes”, then press  $\oplus$ .

#### To change the order of the digital channels

Press  $\rightarrow$ , then press  $\uparrow/\downarrow$  to select the new position for the channel and press  $\leftarrow$ .

**3** Press RETURN.

### Digital Manual Tuning

Tunes the digital channels manually. This feature is available when “Digital Auto Tuning” is set to “Antenna”.

**1** Press the number button to select the channel number you want to manually tune, then press  $\uparrow/\downarrow$  to tune the channel.

**2** When the available channels are found, press  $\uparrow/\downarrow$  to select the channel you want to store, then press  $\oplus$ .

**3** Press  $\uparrow/\downarrow$  to select the programme number where you want to store the new channel, then press  $\oplus$ .

Repeat the above procedure to manually tune other channels.

## Subtitle Set-up

“**Subtitle Setting**”: When “For Hard Of Hearing” is selected, some visual aids may also be displayed with the subtitles (if TV channels broadcast such information).

“**Subtitle Language**”: Selects which language subtitles are displayed in.

---

## Audio Set-up

**“Audio Type”**: Switches to broadcast for the hearing impaired when “For Hard Of Hearing” is selected.

**“Audio Language”**: Selects the language used for a programme. Some digital channels may broadcast several audio languages for a programme.

**“Audio Description”**: Provides audio description (narration) of visual information, if TV channels broadcast such information.

**“Mixing Level”**: Adjusts the TV main audio and Audio Description output levels.

**“Dynamic Range”**: Compensates for differences in the audio level between different channels. Note that this function may have no effect for some channels.

**“Optical Out”**: Selects the audio signal that is output from the DIGITAL OUT (OPTICAL) terminal on the rear of the TV. Set to “Auto” when equipment compatible with Dolby Digital is connected, and set to “PCM” when non-compatible equipment is connected.

---

## Banner Mode

**“Basic”**: Displays programme information with a digital banner.

**“Full”**: Displays programme information with a digital banner, and displays detailed programme information below that banner.

---

## Radio Display

The screen wallpaper is displayed when listening to a radio broadcast. You can select the screen wallpaper colour, or display a random colour. To cancel the screen wallpaper display temporarily, press any button.

---

## Parental Lock

Sets an age restriction for programmes. Any programme that exceeds the age restriction can only be watched after a PIN Code is entered correctly.

**1** Press the number buttons to enter your existing PIN code.

If you have not previously set a PIN, a PIN code entry screen appears. Follow the instructions of “PIN Code” below.

**2** Press  $\uparrow/\downarrow$  to select the age restriction or “None” (for unrestricted watching), then press  $\oplus$ .

**3** Press RETURN.

---

## PIN Code

### To set your PIN for the first time

**1** Press the number buttons to enter the new PIN code.

**2** Press RETURN.

### To change your PIN

**1** Press the number buttons to enter your existing PIN code.

**2** Press the number buttons to enter the new PIN code.

**3** Press RETURN.



PIN code 9999 is always accepted.

---

---

**Technical Set-up**

**“Auto Service Update”**: Enables the TV to detect and store new digital services as they become available.

**“Software Download”**: Enables the TV to automatically receive software updates free through your existing aerial/cable (when issued). It is recommended that this option be set to “On” at all times. If you do not want your software to be updated, set this option to “Off”.

**“System Information”**: Displays the current software version and the signal level.

**“Time Zone”**: Allows you to manually select the time zone you are in, if it is not the same as the default time zone setting for your country/region.

**“Auto DST”**: Sets whether or not to automatically switch between summer time and winter time.

- “Off”: The time is displayed according to the time difference set by “Time Zone”.
- “On”: Automatically switches between summer time and winter time according to the calendar.















---

**CA Module Set-up**

Allows you to access a pay TV service once you obtain a Conditional Access Module (CAM) and a view card. See page 20 for the location of the  (PCMCIA) socket.

---

# Specifications

Model name	KDL-40X3500/40X3000	KDL-46X3500/46X3000	KDL-52X3500
<b>System</b>			
Panel System	LCD (Liquid Crystal Display) Panel		
TV System	Analogue: Depending on your country/region selection: B/G/H, D/K, L, I Digital: DVB-T/DVB-C		
Colour/Video System	Analogue: PAL, SECAM, NTSC 3.58, 4.43 (only Video In) Digital: MPEG-2 MP@ML/HL, MPEG-4 HP@L3/L4		
Channel Coverage	Analogue: VHF: E2–E12/UHF: E21–E69/CATV: S1–S20/HYPER: S21–S41 D/K: R1–R12, R21–R69/L: F2–F10, B–Q, F21–F69/I: UHF B21–B69 Digital: VHF/UHF		
Sound Output	11 W + 11 W		
<b>Input/Output jacks</b>			
Aerial/Cable	75 ohm external terminal for VHF/UHF		
 1	21-pin scart connector (CENELEC standard) including audio/video input, RGB input, and TV audio/video output.		
 2 (SmartLink)	21-pin scart connector (CENELEC standard) including audio/video input, RGB input, selectable audio/video output, and SmartLink interface.		
 3/  4	Supported formats: 1080p, 1080i, 720p, 576p, 576i, 480p, 480i Y: 1 Vp-p, 75 ohms, 0.3V negative sync/Pb/Cb: 0.7 Vp-p, 75 ohms/ Pr/Cr: 0.7 Vp-p, 75 ohms		
 3/  4	Audio input (phono jacks): 500 mVrms, Impedance: 47 kilohms		
HDMI IN 5, 6, 8	Video: 1080/24p, 1080p, 1080i, 720p, 576p, 576i, 480p, 480i Audio: Two channel linear PCM 32, 44.1 and 48 kHz, 16, 20 and 24 bits Analogue audio input (phono jacks): 500 mVrms, Impedance: 47 kilohms (HDMI IN 5 only) PC Input (see page 47)		
 7	S video input (4-pin mini DIN)		
 7	Video input (phono jack)		
 7	Audio input (phono jacks)		
	DIGITAL OUT (OPTICAL) (digital optical jack)/Audio output (phono jacks)		
PC IN 	PC Input (D-sub 15-pin) (see page 47) G: 0.7 Vp-p, 75 ohms, non Sync on Green/B: 0.7 Vp-p, 75 ohms/ R: 0.7 Vp-p, 75 ohms/HD: 1-5 Vp-p/VD: 1-5 Vp-p —  PC audio input (minijack)		
	Headphones jack		
	CAM (Conditional Access Module) slot		
	USB port		

Model name		KDL-40X3500/40X3000	KDL-46X3500/46X3000	KDL-52X3500
<b>Power and others</b>				
Power Requirements		220–240 V AC, 50 Hz		
Screen Size		40 inches (Approx. 101.6 cm measured diagonally)	46 inches (Approx. 116.8 cm measured diagonally)	52 inches (Approx. 132.2 cm measured diagonally)
Display Resolution		1,920 dots (horizontal) × 1,080 lines (vertical)		
Power Consumption		240 W	285 W	320 W
Standby Power Consumption*		0.3 W		
Dimensions (w × h × d)	(with stand)	Approx. 1,111 × 717 × 322 mm	Approx. 1,262 × 795 × 322 mm	Approx. 1,415 × 890 × 384 mm
	(without stand)	Approx. 1,111 × 657 × 123 mm (KDL-40X3500) Approx. 1,111 × 657 × 121 mm (KDL-40X3000)	Approx. 1,262 × 734 × 123 mm (KDL-46X3500) Approx. 1,262 × 734 × 121 mm (KDL-46X3000)	Approx. 1,415 × 827 × 125 mm
Mass	(with stand)	Approx. 31.0 kg	Approx. 38.0 kg	Approx. 49.0 kg
	(without stand)	Approx. 26.0 kg	Approx. 33.0 kg	Approx. 42.0 kg
Supplied Accessories		Refer to “1: Checking the accessories” on page 4.		
Optional Accessories		Wall-Mount Bracket SU-WL500		
		Floor stand SU-FL62		
		Colour Variation Unit CRU-40X1 (KDL-40X3000 only)	Colour Variation Unit CRU-46X1 (KDL-46X3000 only)	

\* Specified standby power is reached after the TV finishes necessary internal processes.

Design and specifications are subject to change without notice.

### PC Input Signal Reference Chart

Signals	Horizontal (Pixel)	Vertical (Line)	Horizontal frequency (kHz)	Vertical frequency (Hz)	Standard
VGA	<b>640</b>	<b>480</b>	<b>31.5</b>	<b>60</b>	<b>VGA</b>
	640	480	37.5	75	VESA
	720	400	31.5	70	VGA-T
SVGA	<b>800</b>	<b>600</b>	<b>37.9</b>	<b>60</b>	<b>VESA Guidelines</b>
	800	600	46.9	75	VESA
XGA	<b>1024</b>	<b>768</b>	<b>48.4</b>	<b>60</b>	<b>VESA Guidelines</b>
	1024	768	56.5	70	VESA
	1024	768	60.0	75	VESA
WXGA	<b>1280</b>	<b>768</b>	<b>47.4</b>	<b>60</b>	<b>VESA</b>
	<b>1280</b>	<b>768</b>	<b>47.8</b>	<b>60</b>	<b>VESA</b>
	1280	768	60.3	75	
	<b>1360</b>	<b>768</b>	<b>47.7</b>	<b>60</b>	<b>VESA</b>
SXGA	<b>1280</b>	<b>1024</b>	<b>64.0</b>	<b>60</b>	<b>VESA</b>
	1280	1024	80.0	75	VESA
HDTV	<b>1920</b>	<b>1080</b>	<b>67.5</b>	<b>60</b>	

- This TV's PC input does not support Sync on Green or Composite Sync.
- This TV's PC input does not support interlaced signals.
- For the best picture quality, it is recommended to use the signals (boldfaced) in the above chart with a 60 Hz vertical frequency from a personal computer. In plug and play, signals with a 60 Hz vertical frequency will be selected automatically.

# Cleaning

Clean the ventilation holes of this TV set regularly (once a month). If dust accumulates, the cooling fan may not operate properly.

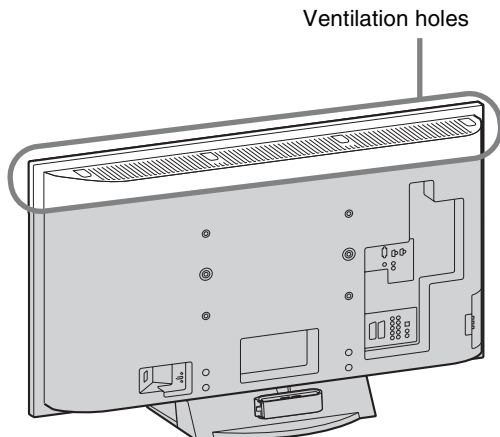

# Troubleshooting

Check whether the  $\text{⏻}$  (standby) indicator is flashing in red.

## When it is flashing

The self-diagnosis function is activated.

- 1 Count how many  $\text{⏻}$  (standby) indicator flashes between each two second break.  
For example, the indicator flashes three times, then there is a two second break, followed by another three flashes, etc.
- 2 Press  $\text{⏻}$  on the right side of the TV to turn it off, disconnect the mains lead, and inform your dealer or Sony service centre of how the indicator flashes (number of flashes).

## When it is not flashing

- 1 Check the items in the tables below.
- 2 If the problem still persists, have your TV serviced by qualified service personnel.

## Picture

### No picture (screen is dark) and no sound

- Check the aerial/cable connection.
- Connect the TV to the mains, and press  $\text{⏻}$  on the right side of the TV.
- If the  $\text{⏻}$  (standby) indicator lights up in red, press TV I/ $\text{⏻}$ .

### No picture or no menu information from equipment connected to the scart connector

- Press  $\text{⏻}$  to display the connected equipment list, then select the desired input.
- Check the connection between the optional equipment and the TV.

### Double images or ghosting

- Check the aerial/cable connection.
- Check the aerial location and direction.

### Only snow and noise appear on the screen

- Check if the aerial is broken or bent.
- Check if the aerial has reached the end of its serviceable life (three to five years in normal use, one to two years at the seaside).

### Distorted picture (dotted lines or stripes)

- Keep the TV away from electrical noise sources such as cars, motorcycles, hair-dryers or optical equipment.
- When installing optional equipment, leave some space between the optional equipment and the TV.
- Make sure that the aerial/cable is connected using the supplied coaxial cable.
- Keep the aerial/cable TV cable away from other connecting cables.

### Picture or sound noise when viewing a TV channel

- Adjust "AFT" (Automatic Fine Tuning) to obtain better picture reception (page 41).



### **Some tiny black points and/or bright points appear on the screen**

- The picture of a display unit is composed of pixels. Tiny black points and/or bright points (pixels) on the screen do not indicate a malfunction.

### **No colour on programmes**

- Select “Reset” (page 28).

### **No colour or irregular colour when viewing a signal from the 3 or 4 sockets**

- Check the connection of the 3 or 4 sockets and check if each socket is firmly seated in its respective socket.

## **Sound**

---

### **No sound, but good picture**

- Press  $\triangleleft$  +/- or  $\times$  (Mute).
- Check if the “Speaker” is set to “TV Speaker” (page 36).
- When using HDMI input with Super Audio CD or DVD-Audio, DIGITAL OUT (Optical) may not provide audio signal.

### **There is a whirring sound**

- This is the sound of the internal fans of the TV (except for KDL-52X3500). This is not a malfunction.

## **Channels**

---

### **The desired channel cannot be selected**

- Switch between digital and analogue mode and select the desired digital/analogue channel.

### **Some channels are blank**

- Scrambled/Subscription only channel. Subscribe to the pay TV service.
- Channel is used only for data (no picture or sound).
- Contact the broadcaster for transmission details.

### **Digital channels are not displayed**

- Contact a local installer to find out if digital transmissions are provided in your area.
- Upgrade to a higher gain aerial.

## **General**

---

### **The TV turns off automatically (the TV enters standby mode)**

- Check if the “Sleep Timer” is activated, or confirm the “Duration” setting of “On Timer” (page 37).
- If no signal is received and no operation is performed in the TV mode for 10 minutes, the TV automatically switches to standby mode.

### **The TV turns on automatically**

- Check if the “On Timer” is activated (page 37).

### **Some input sources cannot be selected**

- Select “AV Preset” and cancel “Skip” of the input source (page 37).

### **The remote does not function**

- Replace the batteries.

### **A channel cannot be added to the Favourite list**

- Up to 999 channels can be stored in the Favourite list.

### **The “Store Display Mode: On” message appears on the screen**

- Select “All Reset” in the “Set-up” menu (page 39).

### **Not all channels are tuned for cable**

- Check support website for cable provide information.  
<http://support.sony-europe.com/TV/DVBC/>

### **The picture contours are disrupted**

- Select “Standard” or “Off” in “Motion Enhancer” (page 34).





**KDL-52X3500**  
**KDL-46X3500 KDL-46X3000**  
**KDL-40X3500 KDL-40X3000**

<http://www.sony.net/>

3-219-178-12(1)

Printed in Spain