

Video Camera Recorder Hi8

Operating Instructions

Before operating the unit, please read this manual thoroughly, and retain it for future reference.

Owner's record

The model and serial numbers are located on the bottom. Record the serial number in the space provided below. Refer to these numbers whenever you call upon your Sony dealer regarding this product.

Model No. CCD-

Model No. AC-

Serial No. _____

Serial No. _____

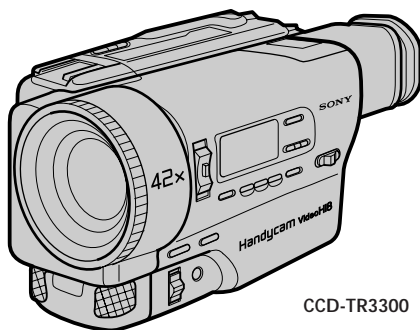

CCD-TR3300

videoHi8 Handycam

CCD-TR2300/TR3300

©1996 by Sony Corporation

Welcome!

Congratulations on your purchase of this Sony Handycam® camcorder. With your Handycam, you can capture life's precious moments with superior picture and sound quality. Your Handycam is loaded with advanced features, but at the same time it is very easy to use. You will soon be producing home video that you can enjoy for years to come.

WARNING

To prevent fire or shock hazard, do not expose the unit to rain or moisture.

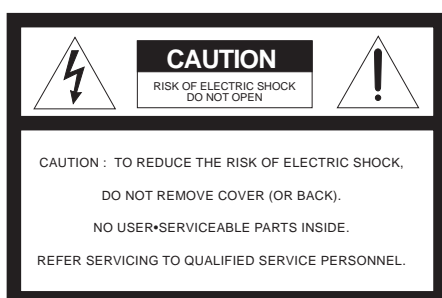

This symbol is intended to alert the user to the presence of uninsulated "dangerous voltage" within the product's enclosure that may be of sufficient magnitude to constitute a risk of electric shock to persons.



This symbol is intended to alert the user to the presence of important operating and maintenance (servicing) instructions in the literature accompanying the appliance.

DISPOSAL OF LITHIUM ION BATTERY. LITHIUM ION BATTERY. DISPOSE OF PROPERLY.

You can return your unwanted lithium ion batteries to your nearest Sony Service Center or Factory Service Center.

Note: In some areas the disposal of lithium ion batteries in household or business trash may be prohibited.

For the Sony Service Center nearest you call 1-800-222-SONY (United States only)

For the Sony Factory Service Center nearest you call 416-499-SONY (Canada only)

Caution: Do not handle damaged or leaking lithium ion battery.

For the customers in the U.S.A.

WARNING

This equipment has been tested and found to comply with the limits for a Class B digital device, pursuant to Part 15 of the FCC Rules. These limits are designed to provide reasonable protection against harmful interference in a residential installation. This equipment generates, uses, and can radiate radio frequency energy and, if not installed and used in accordance with the instructions, may cause harmful interference to radio communications. However, there is no guarantee that interference will not occur in a particular installation. If this equipment does cause harmful interference to radio or television reception, which can be determined by turning the equipment off and on, the user is encouraged to try to correct the interference by one or more of the following measures:

- Reorient or relocate the receiving antenna.
- Increase the separation between the equipment and receiver.
- Connect the equipment into an outlet on a circuit different from that to which the receiver is connected.
- Consult the dealer or an experienced radio/TV technician for help.

You are cautioned that any changes or modifications not expressly approved in this manual could void your authority to operate this equipment.

For the customers in CANADA

CAUTION

TO PREVENT ELECTRIC SHOCK, DO NOT USE THIS POLARIZED AC PLUG WITH AN EXTENSION CORD, RECEPTACLE OR OTHER OUTLET UNLESS THE BLADES CAN BE FULLY INSERTED TO PREVENT BLADE EXPOSURE.

Table of contents

Before you begin

- Using this manual 4
- Checking supplied accessories 5

Getting started

- Charging and installing the battery pack 6
- Inserting a cassette 9

Basic operations

- Camera recording 10
 - Using the zoom feature 12
- Hints for better shooting 14
- Checking the recorded picture 15
- Connections for playback 16
- Playing back a tape 19

Advanced operations

- Using alternative power sources 22
 - Using the house current 22
 - Using the battery case 24
 - Using a car battery 24
- Changing the mode settings 25

— for camera recording —

- Recording with the date or time 28
- Fade-in and fade-out 29
- Overlapping two pictures (CCD-TR3300 only) 31
- Wiping away a still picture (CCD-TR3300 only) 32
- Enjoying picture effect 33
- Recording a still picture (CCD-TR3300 only) 35
- Recording still pictures successively (CCD-TR3300 only) 36
- Superimposing a moving picture on a still picture (CCD-TR3300 only) ... 37
- Re-recording a picture in the middle of a recorded tape 38
- Using the wide mode function 39
- Selecting the START/STOP mode 41
- Superimposing a title 42
- Making your own original titles 45

- Releasing the STEADY SHOT function 46
- Checking the tape condition before recording (ORC) 47

— for manual adjustment —

- Selecting automatic/manual adjustment modes 48
- Focusing manually 49
- Using the PROGRAM AE function 51
 - About the PROGRAM AE function .. 51
 - Using the aperture priority mode .. 51
 - Using the shutter priority mode .. 52
 - Using the twilight mode 53
- Using manual mode 54
- Using slow shutter (CCD-TR3300 only) 57
- Tips for manual adjustment 58
- Shooting with backlighting 60
- Adjusting the brightness of the picture.. 61
- Adjusting the white balance 62

— for playing back/editing —

- Searching the boundaries of recorded date 65
- Returning to a pre-registered position .. 66
- Locating the marking position 67
- Writing the RC Time code on a recorded tape 71
- Editing onto another tape 72
- Recording from a VCR or TV 74

Additional information

- Changing the lithium battery in the camcorder 76
- Resetting the date and time 77
- Usable cassettes and playback modes .. 78
- Tips for using the battery pack 79
- Maintenance information and precautions 81
- Using your camcorder abroad 84
- Trouble check 85
- Specifications 89
- Identifying the parts 90
- Warning indicators 98
- Index 99

Before you begin Using this manual

The instructions in this manual are for the two models listed below. Before you start reading this manual and operating the unit, check your model number by looking at the bottom of your camcorder. The CCD-TR3300 is the model used for illustration purposes. Otherwise, the model name is indicated in the illustrations. Any differences in operation are clearly indicated in the text, for example, "CCD-TR3300 only." As you read through this manual, buttons and settings on the camcorder are shown in capital letters.

e.g. Set the POWER switch to CAMERA.

As indicated with ♪ in the illustrations, you can hear the beep sound to confirm your operation.

Type of differences

Model number		Slow Shutter	Overlap/Wipe	Digital Effect	Easy Connection	Charging attached battery pack	Edit Station
CCD-TR2300		—	—	—	—	—	not supplied
CCD-TR3300	Canadian model	•	•	3 modes	•	•	supplied
	Other than Canadian model	•	•	3 modes	—	—	not supplied

Note on TV color systems

TV color systems differ from country to country. To view your recordings on a TV, you need an NTSC system-based TV.

Precaution on copyright

Television programs, films, video tapes, and other materials may be copyrighted. Unauthorized recording of such materials may be contrary to the provision of the copyright laws.

Precautions on camcorder care

- Do not let sand get into the camcorder. When you use the camcorder on a sandy beach or in a dusty place, protect it from the sand or dust. Sand or dust may cause the unit to malfunction, and sometimes this malfunction cannot be repaired [a].
- Do not let the camcorder get wet. Keep the camcorder away from rain and sea water. Letting the camcorder get wet may cause the unit to malfunction, and sometimes this malfunction cannot be repaired [b].
- Never leave the camcorder exposed to temperatures above 140°F (60°C), such as in a car parked in the sun or under direct sunlight [c].



Contents of the recording cannot be compensated if recording or playback is not made due to a malfunction of the camcorder, video tape, etc.

Checking supplied accessories

Check that the following accessories are supplied with your camcorder.

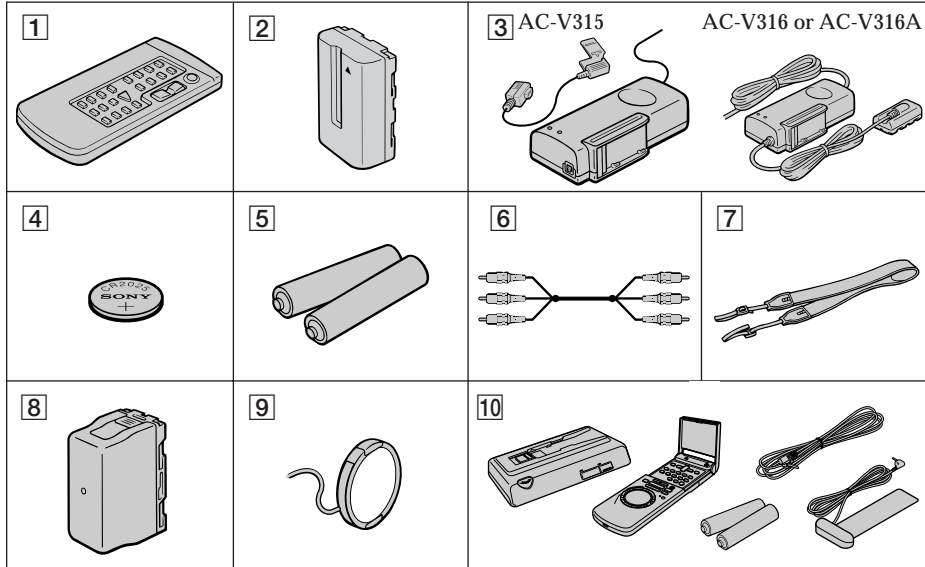

Before you begin

- | | |
|---------------------------------------------------------------------------------------------------------------------------------------------------------------------------------|--------------------------------------------------------------------------------------------------------------------------------------------------------------------------------------------------------------------------------------------|
| <p>1 Wireless Remote Commander (1) (p.94)</p> | <p>Commander (2) (p.94)</p> |
| <p>2 NP-F530 Battery pack (1) (p.6)</p> | <p>6 A/V connecting cable (1) (p.16, 17)</p> |
| <p>3 AC power adaptor (1) (p.6, 22)
AC-V315 is for CCD-TR3300 for Canadian model
AC-V316 or AC-V316A is for CCD-TR3300 for other than Canadian model and CCD-TR2300</p> | <p>7 Shoulder strap (1) (p.96)</p> |
| <p>4 CR2025 Lithium Battery (1) (p.76)
The lithium battery is already installed in your camcorder.</p> | <p>8 Battery case (1) (p.24)</p> |
| <p>5 Size AA (R6) battery for Remote</p> | <p>9 Lens cap (1) (p.10, 64)
This lens cap is already set on your camcorder.</p> |
| | <p>10 Edit Commander Station (Edit Station) (1) and Remote Commander (1) supplied with IR repeater (1), adhesive tape (1), control-S connecting cable (1) and size AA (R6) battery (2) (only for CCD-TR3300 for Canadian model) (p.17)</p> |

Getting started

Charging and installing the battery pack

Before using your camcorder, you first need to charge and install the battery pack. To charge the battery pack, use the supplied AC power adaptor.

This camcorder operates with the “InfoLITHIUM” battery labeled (i) *InfoLITHIUM* such as NP-F530/F730. If you use any other battery to operate your camcorder, the camcorder may not operate or the battery life may be shortened.

“InfoLITHIUM” is a trademark of Sony Corporation.

Charging the battery pack

Charge the battery pack on a flat surface without vibration.

- (1) Connect the power cord to a wall outlet.
- (2) Align the surface of the battery pack indicated by the ► mark with the edge of the terminal shutter of the AC power adaptor. Then fit and slide the battery pack in the direction of the arrow. The CHARGE lamp (orange) lights up. Charging begins.

When charging is completed, the CHARGE lamp goes out. If the battery pack is used right after the CHARGE lamp goes out, it will last for a normal period (**normal charge**). If allowed to charge for an additional hour or so, the battery pack will last for a longer period (**full charge**). Unplug the unit from the wall outlet, then remove the battery pack and install it into the camcorder. You can also use the battery pack before it is completely charged.

AC-V315 for CCD-TR3300 for Canadian model

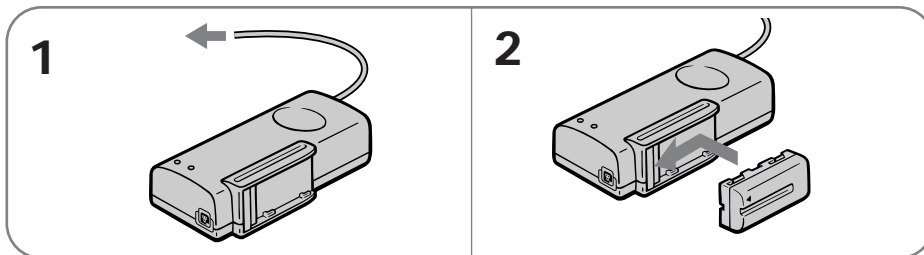

AC-V316/V316A for CCD-TR3300 for other than Canadian model and CCD-TR2300

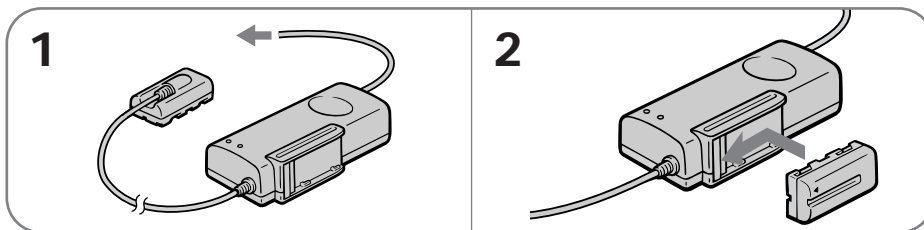

Charging time

Battery pack	NP-F530 (supplied)	NP-F730
Charging time* (min.)	170 (110)	250 (190)

* Approximate minutes to charge an empty battery pack using the supplied AC power adaptor (full charge). (Lower temperatures require a longer charging time.)
The time required for a normal charge is indicated in parentheses.

Battery life

— CCD-TR3300

Battery pack	NP-F530 (supplied)	NP-F730
Continuous recording time ¹⁾ (min.)	105 (95)	240 (215)
Typical recording time ²⁾ (min.)	65 (55)	145 (130)

— CCD-TR2300

Battery pack	NP-F530 (supplied)	NP-F730
Continuous recording time ¹⁾ (min.)	110 (95)	245 (220)
Typical recording time ²⁾ (min.)	65 (55)	145 (130)

The available time for a fully charged battery is indicated outside parentheses. The available time for normal charged battery is indicated in parentheses. Battery life will be shorter if you use the camcorder in a cold environment.

- 1) Approximate continuous recording time indoors.
- 2) Approximate minutes when recording while you repeat recording start/stop, zooming and turning the power on/off. The actual battery life may be shorter.

Note on remaining battery time indication during recording

When you use the "InfoLITHIUM" battery pack NP-F530 or NP-F730, remaining battery time is displayed in the viewfinder. However, the indication may not be displayed properly, depending on using conditions and circumstances.

Charging and installing the battery pack

To remove the battery pack

Slide the battery pack in the direction of the arrow.

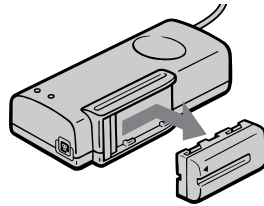

AC-V315

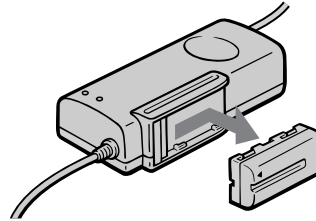

AC-V316/V316A

Notes on charging the battery pack

- The CHARGE lamp will remain lit for a while even if the battery pack is removed and the power cord is unplugged after charging the battery pack. This is normal.
- If the CHARGE lamp does not light, disconnect the power cord. After about one minute, reconnect the power cord again.
- You cannot operate the camcorder using the AC power adaptor while charging the battery pack.
- When a fully charged battery pack is installed, the CHARGE lamp will light once, then go out.

Installing the battery pack

Align the grooves of the battery pack with the receptacles of the camcorder and slide the battery pack down until it catches on the battery release lever and clicks.

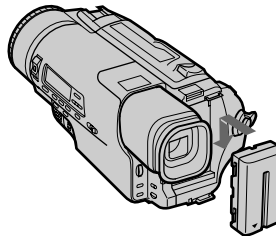

To remove the battery pack

While pressing BATT (battery) PUSH, slide the battery pack in the direction of the arrow.

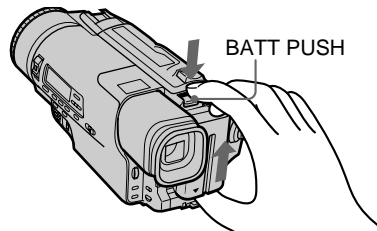

Inserting a cassette

Make sure that the power source is installed. When you want to record in the Hi8 system, use Hi8 video cassette **Hi8**.

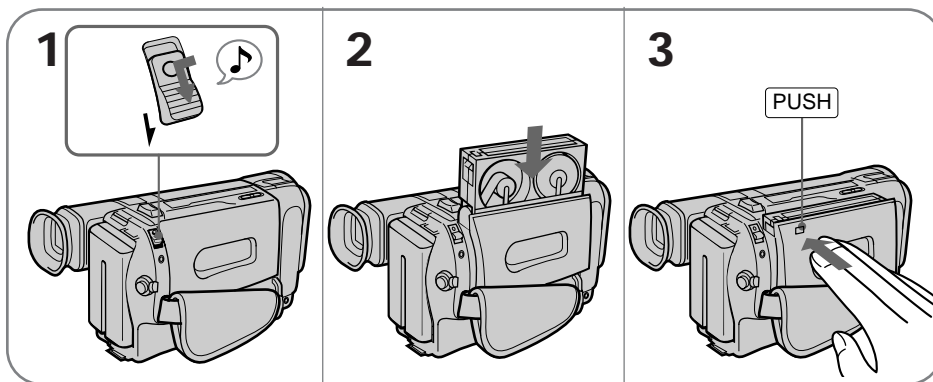

- (1) While pressing the small blue button on the EJECT switch, slide it in the direction of the arrow. The cassette compartment automatically lifts up and opens.
- (2) Insert a cassette with the window facing out.
- (3) Close the cassette compartment by pressing the "PUSH" mark on the cassette compartment. The cassette compartment automatically goes down.



To eject the cassette

While pressing the small blue button on the EJECT switch, slide it in the direction of the arrow.

To prevent accidental erasure

Slide the tab on the cassette to expose the red mark. If you insert the cassette with the red mark exposed and close the cassette compartment, the beeps sound for a while. If you try to record with the red mark exposed, the  and  indicators flash in the viewfinder, and you cannot record.

To re-record on this tape, slide the tab back out covering the red mark.

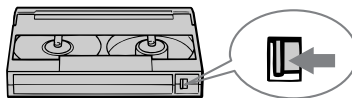

Basic operations

Camera recording

Make sure that the power source is installed and a cassette is inserted. Before you record one-time events, you may want to make a trial recording to make sure that the camcorder is working correctly.

When you use the camcorder for the first time, power on it and reset the date and time to your time before you start recording. (p.77) To save battery power, the picture in the viewfinder appears only when you bring your face close to the viewfinder with STANDBY up (Finder power save).

- (1) Remove the lens cap.
- (2) While pressing the small green button on the POWER switch, set it to CAMERA.
- (3) Turn STANDBY up.
- (4) Press START/STOP. The camcorder starts recording. The "REC" indicator appears and the red lamp lights up in the viewfinder. The camera recording/battery lamps located on the front light up.

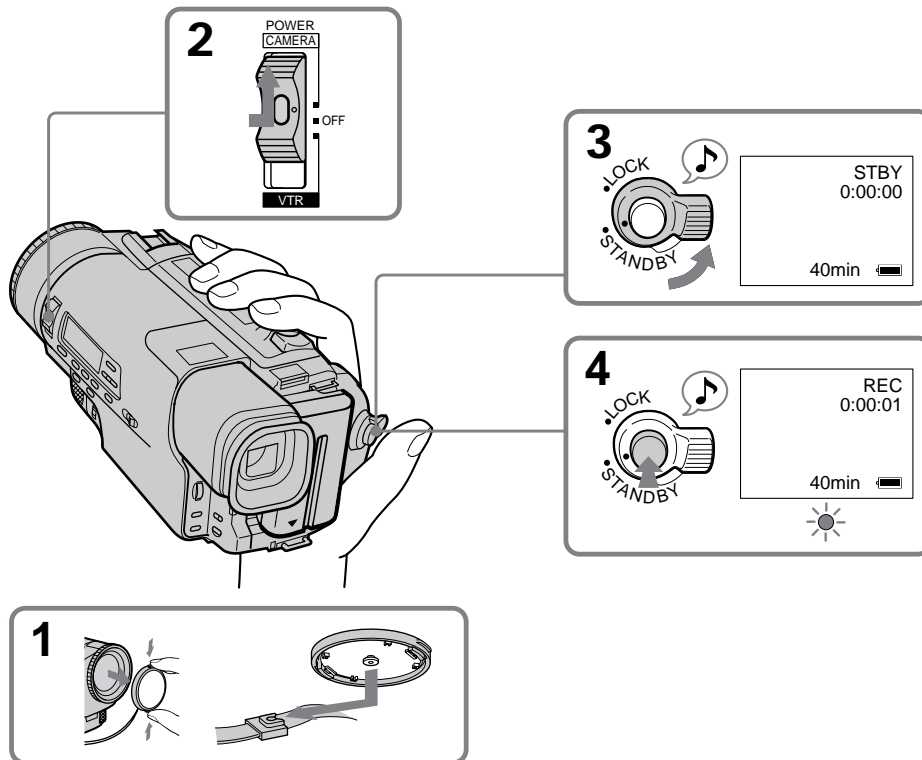

To stop recording momentarily [a]

Press START/STOP again. The “STBY” indicator appears in the viewfinder (Standby mode).

To finish recording [b]

Press START/STOP again. Turn STANDBY down and set the POWER switch to OFF. Then, eject the cassette, remove the battery pack and put the lens cap on the lens.



To focus the viewfinder lens

If you cannot see the indicators in the viewfinder clearly, or after someone else has used the camcorder, focus the viewfinder lens. Move the viewfinder lens adjustment lever so that the indicators in the viewfinder come into sharp focus.

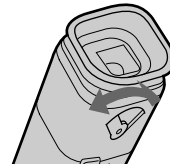

Note on Standby mode

If you leave the camcorder in Standby mode for 5 minutes while the cassette is inserted, the camcorder turns off automatically. This prevents wearing down the battery and wearing out the tape. To resume Standby mode, turn STANDBY down once and then up again. To start recording, press START/STOP.

Notes on recording mode

- This camcorder records and plays back in SP (standard play) mode and in LP (long play) mode. The playback quality in LP mode, however, will not be as good as that in SP mode.
- In LP mode, you cannot record tapes in the Hi8 system.
- When a tape recorded on this camcorder in LP mode is played back on other types of 8 mm camcorders or VCRs, the playback quality may not be as good as that on this camcorder.

Note on recording

When you record from the beginning of a tape, run the tape for about 15 seconds before starting the actual recording. This will ensure that you won't miss any start-up scenes when you play back the tape.

Notes on the tape counter

- The tape counter indicates the recording or playback time. Use it as a guide. There will be a time lag of several seconds from the actual time. To set the counter to zero, press COUNTER RESET.
- If the tape is recorded in SP and LP modes mixed, the tape counter shows incorrect recording time. When you intend to edit the tape using the tape counter, record in same (SP or LP) mode.

Camera recording

Note on the beep sound

As indicated with ♩ in the illustrations, a beep sounds when you turn the power on or when you start recording, and two beeps sound when you stop recording, confirming the operation. Several beeps also sound as a warning of any unusual condition of the camcorder.

Note that the beep sound is not recorded on the tape. If you do not want to hear the beep sound, select "OFF" in the menu system.

Notes on finder power save

- The recording continues even when the picture in the viewfinder disappears during recording.
- If you set VF PW-SAVE to OFF in the menu system, the picture in the viewfinder does not disappear even when you turn your face away from the viewfinder.

When moving from indoors to outdoors (or vice versa)

Turn STANDBY up and point the camcorder at a white object for about 15 seconds so that the white balance is properly adjusted.

Using the zoom feature

Zooming is a recording technique that lets you change the size of the subject in the scene.

For more professional-looking recordings, use the zoom function sparingly.

"T" side: for telephoto (subject appears closer)

"W" side: for wide-angle (subject appears farther away)

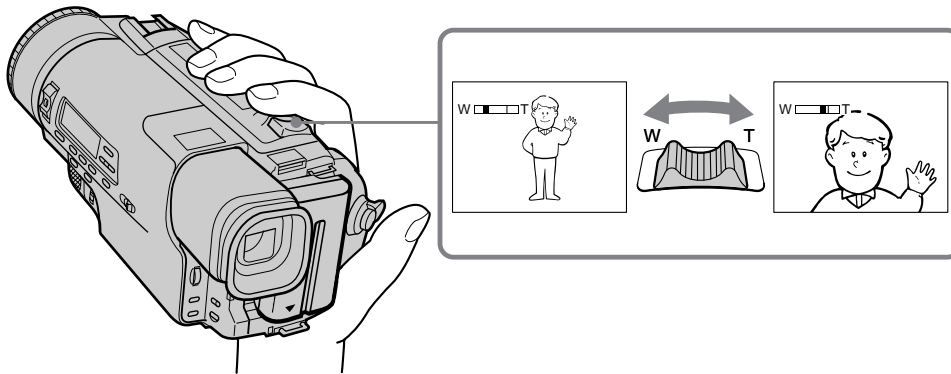

Zooming speed (Variable speed zooming)

Move the power zoom lever a little for a slower zoom, move it further for a faster zoom.

When you shoot a subject using a telephoto zoom

If you cannot get a sharp focus while in extreme telephoto zoom, move the power zoom lever to the "W" side until the focus is sharp. You can shoot a subject that is at least about 2 5/8 feet (about 80 cm) away from the lens surface in the telephoto position, or about 1/2 inch (about 1 cm) away in the wide-angle position.



Notes on digital zoom

- More than 21x zoom is performed digitally (42x), and the picture quality deteriorates as you go toward the “T” side. If you do not want to use the digital zoom, set the D ZOOM function to OFF in the menu system.
- The right side [a] in the power zoom indicator shows the digital zooming zone, and the left side [b] shows the optical zooming zone. If you set the D ZOOM function to OFF, the [a] zone disappears.



Hints for better shooting

For hand-held shots, you'll get better results by holding the camcorder according to the following suggestions:

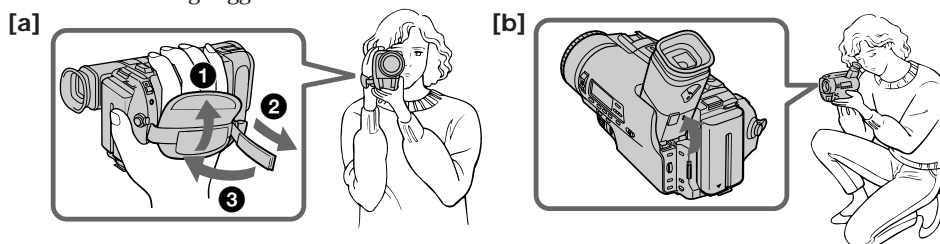

- Hold the camcorder firmly and secure it with the grip strap so that you can easily manipulate the controls with your thumb [a].
- Place your right elbow against your side.
- Place your left hand under the camcorder to support it. Be sure to not touch the built-in microphone.
- Place your eye firmly against the viewfinder eyecup.
- Use the viewfinder frame as a guide to determine the horizontal plane.
- You can also record in a low position to get an interesting angle. Lift the viewfinder up for recording from a low position [b].

Place the camcorder on a flat surface or use a tripod

Try placing the camcorder on a table top or any other flat surface of suitable height. If you have a tripod for a still camera, you can also use it with the camcorder.

When attaching a non-Sony tripod, make sure that the length of the tripod screw is less than 9/32 inch (6.5 mm). Otherwise, the screw may damage the inner parts of the camcorder.

If you wear glasses

You can bend back the eyecup to get a better view of viewfinder [c].

Cautions on the viewfinder

- Do not pick up the camcorder by the viewfinder [d].
- Do not place the camcorder so as to point the viewfinder toward the sun. The inside of the viewfinder may be damaged. Be careful when placing the camcorder under sunlight or by a window [e].

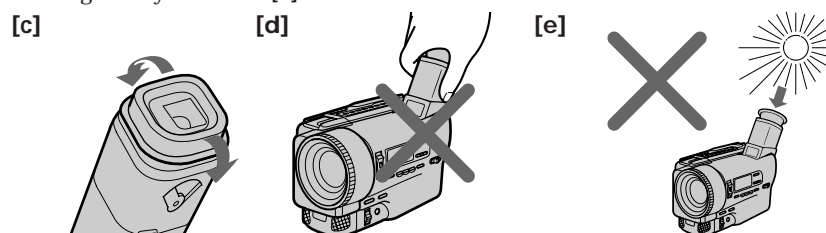

Notes on the color viewfinder

- The color viewfinder employs LCD screen made with high-precision technology. However, black points or bright points of light (red, blue, or green) may appear constantly on the color viewfinder screen. These points are not recorded on the tape. This is not a malfunction. (Effective dots : more than 99.99%).
- The finder power save function sometimes does not operate due to the effects of sunlight or fluorescent light.
- In direct sunlight, the picture in the viewfinder looks brighter by the lighting aperture. The color of the picture in the viewfinder is variable in such a case.

Checking the recorded picture

Using EDITSEARCH, you can review the last recorded scene or check the recorded picture in the viewfinder.

- (1) While pressing the small green button on the POWER switch, set it to CAMERA.
- (2) Turn STANDBY up.
- (3) Press the - side of EDITSEARCH momentarily; the last few seconds of the recorded portion play back (Rec Review).

Hold down the - side of EDITSEARCH until the camcorder goes back to the scene you want. The last recorded portion is played back. To go forward, hold down the + side (Edit Search).

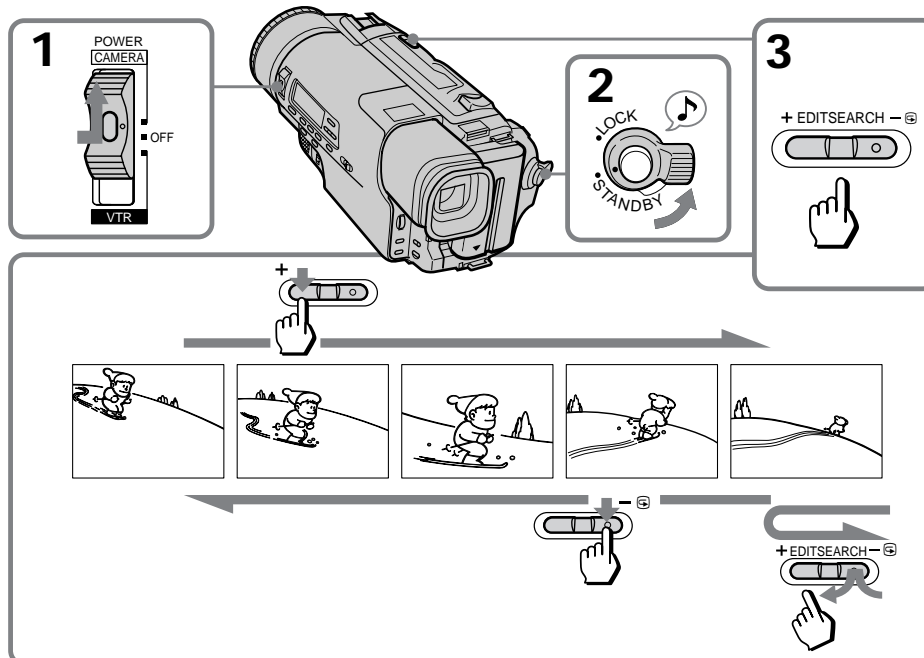

To stop playback

Release EDITSEARCH.

To begin re-recording

Press START/STOP. Re-recording begins from the point you released EDITSEARCH. Provided you do not eject the tape, the transition between the last scene you recorded and the next scene you record will be smooth.

Connections for playback

You can use this camcorder as a VCR by connecting it to your TV for playback. There are some ways to connect the camcorder to your TV. When monitoring the playback picture by connecting the camcorder to your TV, we recommend you to use house current for the power source.

Connecting directly to a VCR/TV with Video/Audio input jacks

If your TV is already connected to a VCR

Open the jack cover and connect the camcorder to the LINE IN inputs on the VCR by using the supplied A/V connecting cable. Set the input selector on the VCR to LINE. Set the TV/VCR selector on the TV to VCR.

If you are going to connect the camcorder using the S video cable (not supplied) [a], you do not need to connect the yellow (video) plug of the A/V connecting cable [b].

If you use a monaural A/V connecting cable, you will get monaural sound.

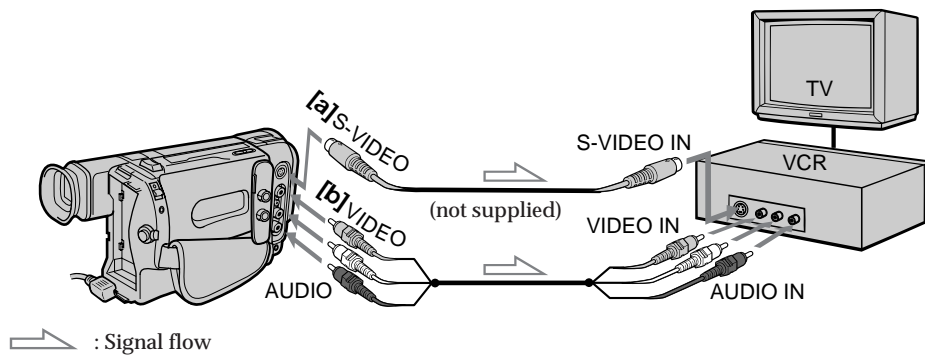

If you connect directly to TV

Open the jack cover and connect the camcorder to the inputs on the TV by using the supplied A/V connecting cable. Set the TV/VCR selector on the TV to VCR.

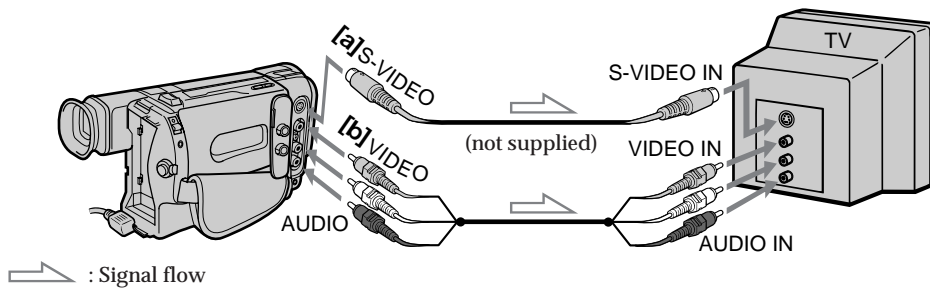

If your VCR or TV is a monaural type

Connect only the white plug for audio on both the camcorder and the VCR or the TV. With this connection, the sound is monaural.

To connect to a VCR or TV without Video/Audio input jacks

Use the RFU-95UC adaptor (not supplied).

Connecting to a VCR/TV using the Edit Station — CCD-TR3300 for Canadian model only

Once you connect the supplied HSA-EC1 Edit Station to your TV or VCR, you can easily view the picture on your TV. For using the Edit Station, see the operating instructions supplied with the Edit Station.

If your TV is already connected to a VCR

Connect the Edit Station to the LINE IN inputs on the VCR by using the supplied A/V connecting cable. Set the input selector on the VCR to LINE. Set the TV/VCR selector on the TV to VCR.

If you are going to connect the Edit Station using the S video cable (not supplied) [a], you do not need to connect the yellow (video) plug of the A/V connecting cable [b].

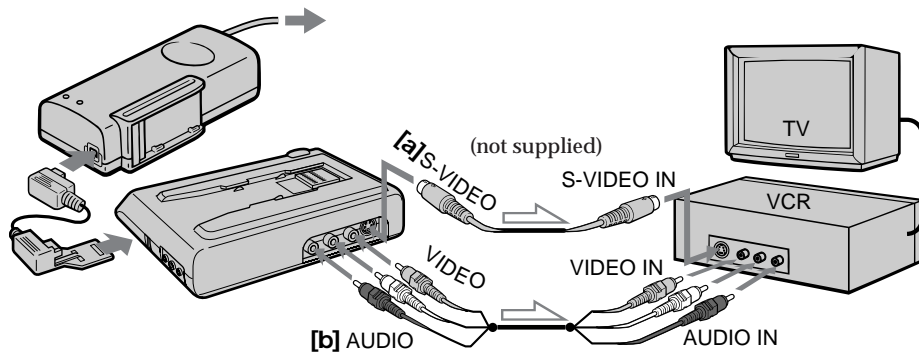

➤ : Signal flow

If you connect directly to TV

Connect the Edit Station to the inputs on the TV using the supplied A/V connecting cable. Set the TV/VCR selector on the TV to VCR.

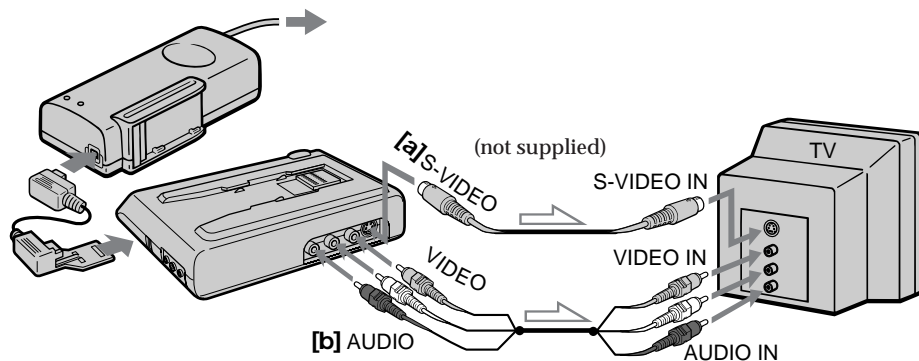

➤ : Signal flow

If your VCR or TV is a monaural type

Connect only the white plug for audio on both the Edit Station and the TV or VCR. With this connection, the sound is monaural.

Connections for playback

To connect the camcorder to the Edit Station

- (1) Connect the power cord of the supplied AC power adaptor to a wall outlet.
- (2) Connect the supplied connecting cord to the DC OUT jack on the AC power adaptor.
- (3) Insert the connecting plate into the guides at the bottom of the Edit Station.
- (4) Set the POWER switch of the camcorder to OFF.
- (5) Aligning the bottom of the camcorder with the arrow mark on the Edit Station, slide the camcorder along the guide until it clicks.
- (6) Set the POWER switch of the camcorder to VTR.

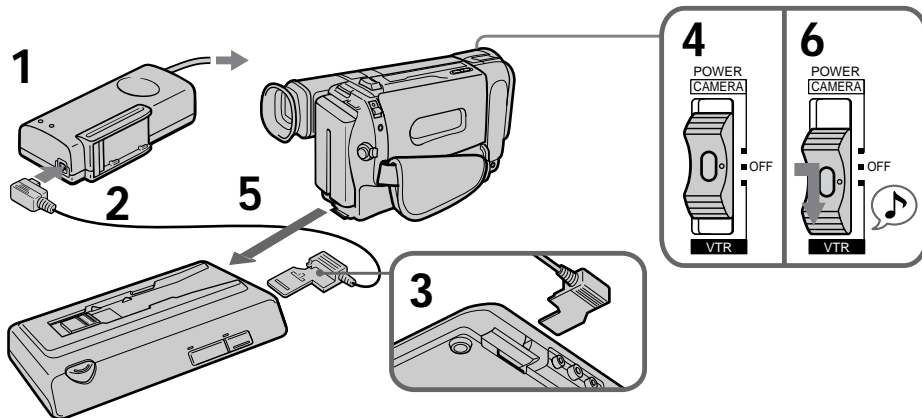

Caution

Do not set the POWER switch to CAMERA. The Edit Station can be used only for VTR mode.

To remove the camcorder

- (1) Set the POWER switch of the camcorder to OFF.
- (2) While pressing HANDYCAM RELEASE on the Edit Station, slide the camcorder.

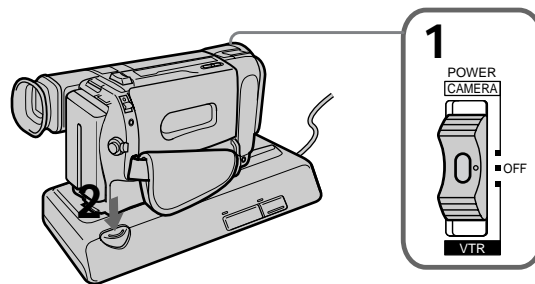

Playing back a tape

You can monitor the playback picture in the viewfinder. You can also monitor a picture on a TV screen, after connecting the camcorder to a TV or VCR.

- (1) While pressing the small green button on the POWER switch, set it to VTR. The tape transport buttons light up.
- (2) Insert the recorded tape with the window facing out.
- (3) Press \blacktriangleright to start playback.

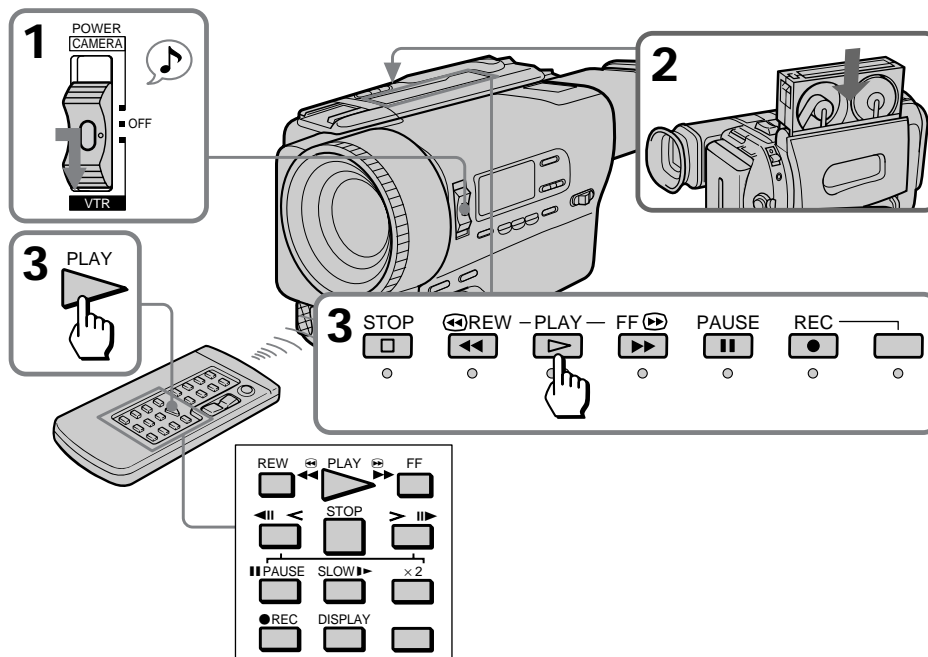

- To stop playback, press \square .
- To rewind the tape, press \ll .
- To fast-forward the tape rapidly, press \gg .

Using the remote commander

You can control playback using the supplied Remote Commander. Before using the Remote Commander, insert the size AA (R6) batteries.

Using the Edit Station — CCD-TR3300 for Canadian model only

You can control playback using the buttons and jog dial on the Edit Station. To use the jog dial, turn the shuttle ring clockwise or counterclockwise to point the desired indication around the ring. When using the Remote Commander with the Edit Station, set COMMAND MODE on the Edit Station to VTR 2.

To display the viewfinder screen indicators on the TV

Press DISPLAY on the Remote Commander. To erase the indicators, press DISPLAY again.

To monitor the sound while viewing the playback picture in the viewfinder

Connect headphones (not supplied) to the \odot jack.

Playing back a tape

Various playback modes

To view a still picture (playback pause)

Press **II** during playback. To resume playback, press **II** or **▷**.

To locate a scene (picture search)

Keep pressing **◀◀** or **▶▶** during playback. To resume normal playback, release the button.

To monitor the high-speed picture while advancing the tape or rewinding (skip scan)

Keep pressing **◀◀** while rewinding or **▶▶** while advancing the tape. To resume normal playback, press **▷**.

To view the picture at 1/5 speed (slow playback)

Press **SLOW ▶** on the Remote Commander during playback. To resume normal playback, press **▷**. If slow playback lasts for about 1 minute, it shifts to normal speed automatically.

To view the picture at double speed

For double speed playback in the reverse direction, press **◀II<**, then press x2 on the Remote Commander during playback. For double speed playback in the forward direction, press **>II▶**, then press x2 during playback. To resume normal playback, press **▷**.

To view the picture frame-by-frame

Press **◀II<** or **>II▶** on the Remote Commander in playback pause mode. If you keep pressing the button, you can view the picture at 1/25 speed. To resume normal playback, press **▷**.

To change the playback direction

Press **◀II<** on the Remote Commander for reverse direction or **>II▶** on the Remote Commander for forward direction during playback. To resume normal playback, press **▷**.

To select the playback sound

Change the "HiFi SOUND" mode setting in the menu system.

Notes on playback

- Streaks appear and the sound is muted in the various playback modes.
- When playback pause mode lasts for 5 minutes, the camcorder automatically enters stop mode.
- Horizontal noise appears at the center of the screen when you play back a tape in reverse or in various speed if the RC time code or the Data Code is displayed on the screen. This is normal.
- The playback picture may be shaken up and down in slow playback. This is normal.

Displaying the date or time when you recorded - data code function

Even if you did not record the date or time when you were recording, you can display the date or time when you recorded (Data Code) on the TV during playback or editing. The Data Code is also displayed in the viewfinder and the display window.

To display the date when you recorded

Press DATE on the camcorder, or press DATA CODE on the Remote Commander. To make the date disappear, press DATE again or DATA CODE twice.

To display the time when you recorded

Press TIME on the camcorder, or press DATA CODE on the Remote Commander twice. To make the time disappear, press it again.

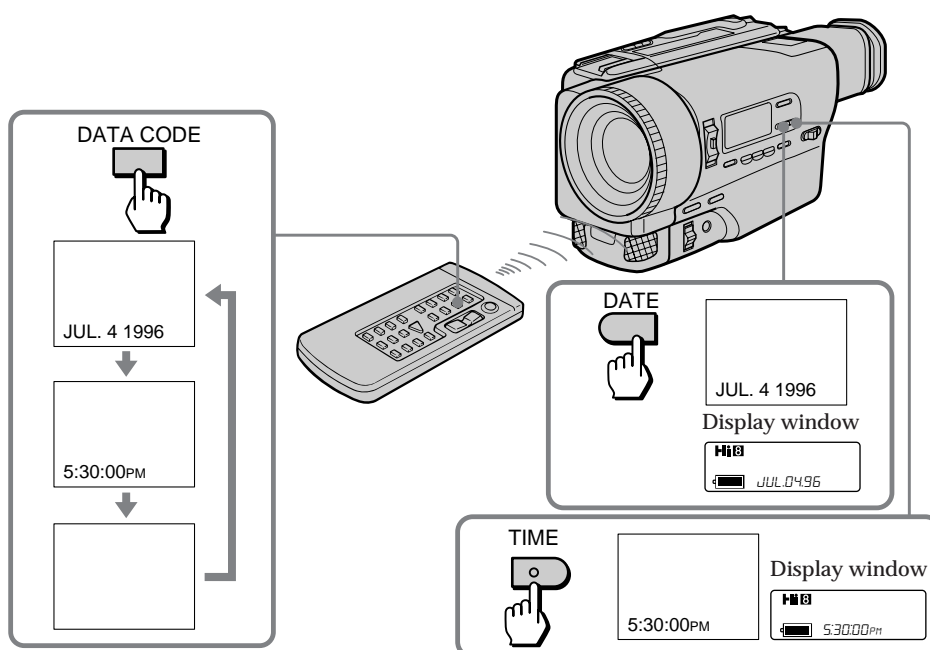

When bars (---:---:---) appear

- A blank portion of the tape is being played back.
- The tape was recorded by a camcorder without the Data Code function.
- The tape was recorded by a camcorder without having date and time set.
- The tape is unreadable due to tape damage or noise.
- The tape was recorded in LP mode.
- The tape is being played back in variable speed (Slow Playback, etc.)
- An index signal is marked, the RC time code is written, or PCM after recording is made on the tape.

Advanced operations

Using alternative power sources

You can choose any of the following power sources for your camcorder: battery pack, house current, alkaline battery and 12/24 V car battery. Choose the appropriate power source depending on where you want to use your camcorder.

Place	Power source	Accessory to be used
Indoors	House current	Supplied AC power adaptor
		Edit Station HSA-EC1 (supplied for CCD-TR3300 for Canadian model only)*
Outdoors	Battery pack	Battery pack NP-F530 (supplied), NP-F730
	Size AA (LR6) Sony Alkaline battery	Battery case (supplied)
In the car (CCD-TR3300 for Canadian model only)	12 V or 24 V car battery	Car battery charger DC-V515

* Edit Station HSA-EC1 cannot be used for camera recording.

Note on power sources

Disconnecting the power source or removing the battery pack during recording or playback may damage the inserted tape. If this happens, restore the power supply again immediately.

Using the house current

To use the supplied AC power adaptor:

CCD-TR3300 for Canadian model only:

- (1) Connect the AC power cord to a wall outlet, then connect the connecting cord to the DC OUT jack on the AC power adaptor.
- (2) Insert the connecting plate into the guides at the bottom of the camcorder.

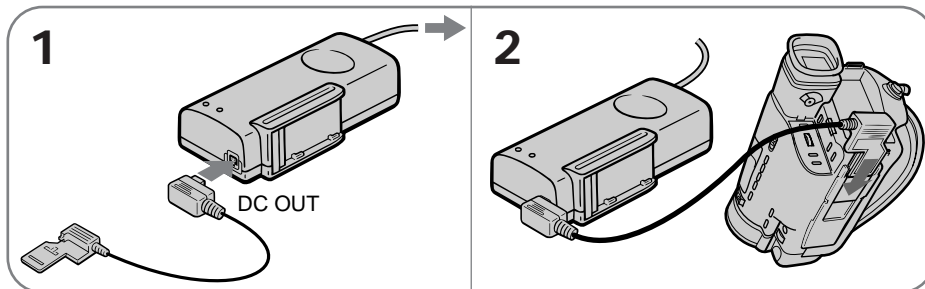

CCD-TR3300 for other than Canadian model and CCD-TR2300 only:

- (1) Connect the AC power cord to a wall outlet.
- (2) Slide the connecting plate down into the guides at the rear of the camcorder until it clicks.

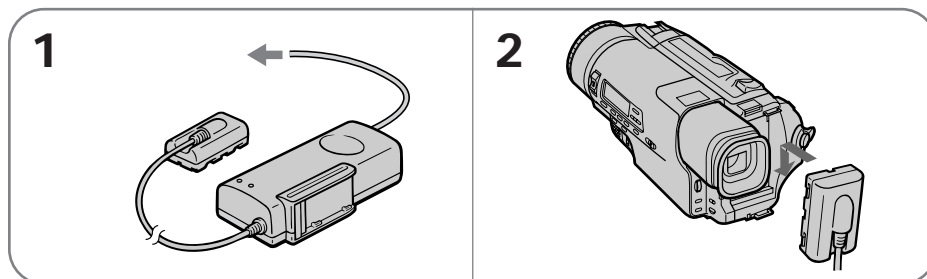

Charging the battery pack

—CCD-TR3300 for Canadian model only

After connecting the power cord to the house current and setting the POWER switch on the camcorder to OFF, you can charge the battery pack in either of the following two ways: (When charging begins, the CHARGE lamp lights.)

- Charging the battery attached to the camcorder
Leave the battery pack attached to the camcorder. (The NP-F530 battery pack requires about 210 minutes for a full charge and about 150 minutes for a normal charge.)
- Charging two battery packs at the same time
Attach one battery pack to the AC power adaptor and the other to the camcorder. Both are charged simultaneously. When charged, both lamps go out (normal charge). If either lamp is still lit, both batteries are not charged (the NP-F530 battery packs require about 240 minutes for a full charge and about 180 minutes for a normal charge).

You can also charge the battery pack in either of the above two ways by connecting the AC power adaptor to the Edit Station and setting the POWER switch on the Edit Station to OFF.

Notes on the VTR/CAMERA lamp

- The VTR/CAMERA lamp will remain lit for a while even if the unit is unplugged after use. This is normal.
- If the VTR/CAMERA lamp does not light, disconnect the power cord. After about 1 minute, reconnect the power cord.

To remove the connecting plate

Pull out the connecting plate by the plate. Never pull the connecting cord itself.

WARNING

The power cord must only be changed at a qualified service shop.

PRECAUTION

The set is not disconnected from the AC power source (house current) as long as it is connected to the house current, even if the set itself has been turned off.

Using alternative power sources

Using the battery case

Use the battery case (supplied) and six size AA (LR6) Sony Alkaline batteries (not supplied).

- (1) Remove the battery holder from the battery case.
- (2) Insert six new alkaline batteries into the battery holder, following the marking on the holder to be sure the batteries are installed in the correct direction.
- (3) Insert the battery holder with the alkaline batteries.
- (4) Insert the battery case with the alkaline batteries to the battery mounting surface of the camcorder in the same way as the battery pack.

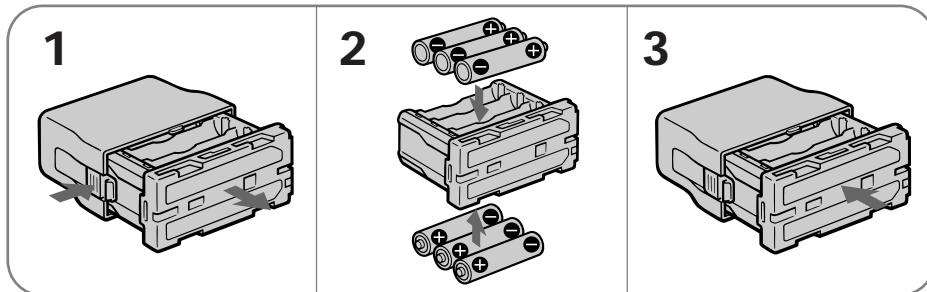

Battery life

Using Sony alkaline batteries at 77°F (25°C).

Model	Continuous recording time	Typical recording time
CCD-TR3300	115 min.	70 min.
CCD-TR2300	120 min.	70 min.

Notes on the battery life

- You may not use the battery case in cold environment.
- The battery life may be shorter depending on the using environment.
- The battery lives on the previous page are estimates. the battery life may be shorter depending on the storage condition of the battery before being purchased and temperature.

To remove the battery case

The battery case is removed in the same way as the battery pack.

Using a car battery

— CCD-TR3300 for Canadian model only

Use the DC-V515 car battery charger (not supplied). Connect the car battery cord to the cigarette lighter socket of a car (12 V or 24 V). Connect the car battery cord to the camcorder in the same way as you connect the AC power adaptor.



This mark indicates that this product is a genuine accessory for Sony video products.

When purchasing Sony video products, Sony recommends that you purchase accessories with this "GENUINE VIDEO ACCESSORIES" mark.

Changing the mode settings

You can change the mode settings in the menu system to further enjoy the features and functions of the camcorder.

- (1) Press MENU to display the menu.
- (2) Turn the control dial so that the desired item is highlighted white.
- (3) Press the control dial. The setting menu appears.
- (4) Turn the control dial to highlight a setting, and press the control dial to select it.
- (5) If you want to change the other modes, repeat steps 2 to 4.
- (6) Press MENU to erase the menu display.

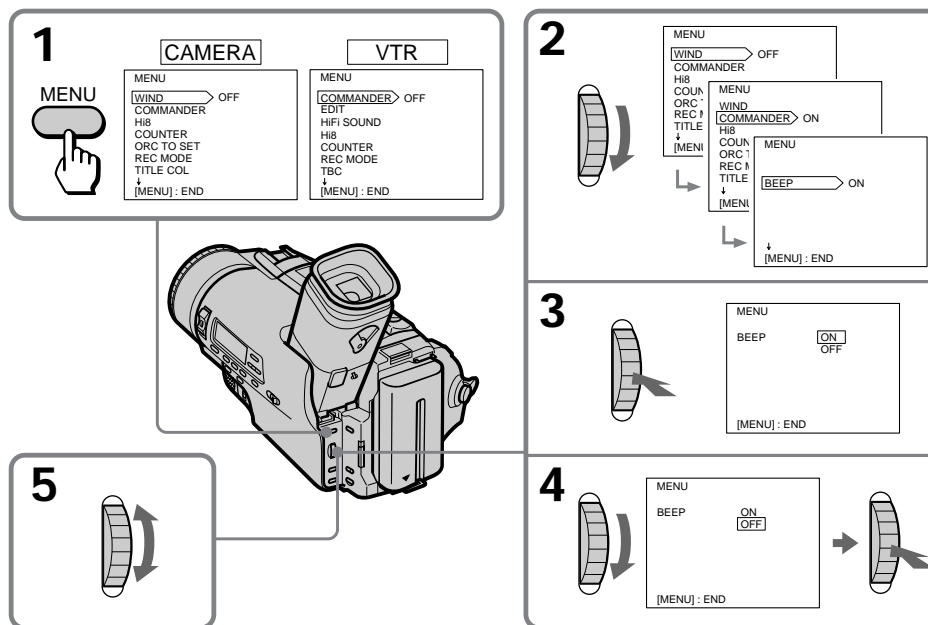

Selecting the mode setting of each item

Items for both CAMERA and VTR modes

COUNTER <NORMAL/TIME CODE>

- Normally select NORMAL.
- Select TIME CODE to display the RC time code in order to edit more precisely.

COMMANDER <ON/OFF>

- Select ON when using the supplied Remote Commander for the camcorder.
- Select OFF when not using the Remote Commander.

BEEP <ON/OFF>

- Select ON so that beeps sound when you start/stop recording, etc.
- Select OFF when you do not want to hear the beep sound.

Changing the mode settings

VF BRIGHT*

Select this item to adjust the brightness of the viewfinder. The viewfinder becomes brighter when you turn the control dial up, and darker when you turn the control dial down.

VF PW-SAVE* <ON/OFF>

- Select ON to activate finder power save function.
- Select OFF to not use finder power save function.

Items for CAMERA mode only

WIND <ON/OFF>

- Select ON to reduce wind noise when recording in strong wind.
- Normally select OFF.

Hi8 <AUTO/OFF>

- Normally select AUTO to have the camcorder automatically set the recording mode (Hi8 or standard 8 mm) depending upon the cassette type being used.
- Select OFF to record a Hi8 tape in standard 8 mm format.

ORC TO SET* <ORC ON>

Select ORC ON to automatically adjust the recording condition to get the best possible recording.

REC MODE* <SP/LP>

- Select SP when recording in SP (standard play) mode.
- Select LP when recording in LP (long play) mode.

D ZOOM* <ON/OFF>

- Select ON to activate digital zooming.
- Select OFF to not use the digital zoom. The camera goes back to 21x zoom.

REC LAMP* <ON/OFF>

- Select OFF when you do not want the camera recording/battery lamp at the front of the unit to light up.
- Normally select ON.

AE SHIFT*

Select this item to adjust the brightness of the picture.

TITLE COL* <BLUE/ GREEN/ CYAN/ RED/ VIOLET/ YELLOW/ WHITE>

Select the color of the title.

TITLE POS* <CENTER/BOTTOM>

- Select CENTER to center the title in the picture.
- Select BOTTOM to position the title at the bottom of the picture.

TITLE LANG* <ENGLISH/ FRANÇAIS/ ESPAÑOL/ PORTUGUÊS>

Select the language of the preset titles.

TITLE 1 SET* TITLE 2 SET*

Select to store your own original titles.

CLOCK SET*

Select this item to reset the date or time.



Items for VTR mode only

EDIT <ON/OFF>

- Select ON to minimize picture deterioration when editing.
- Normally select OFF.

HiFi SOUND <STEREO/1/2>

- Normally select STEREO.
- Select 1 or 2 to play back a dual sound track tape.

TBC* <ON/OFF>

- Select ON to correct for jitter.
- Select OFF to not correct for jitter. The picture may not be steady when you playback.

DNR* <ON/OFF>

- Select ON to reduce picture noise.
- Select OFF to not reduce noise.

* These settings are retained even when the battery is removed, as long as the lithium battery is in place.

Note on TBC setting

Set TBC to OFF when playing back:

- A tape you have dubbed over.
- A tape on which you recorded the signal of a TV game or similar machine.

Recording with the date or time

Before you start recording or during recording, press DATE or TIME. You can record the date or time displayed in the viewfinder with the picture. You cannot record the date and time at the same time. Except for the date or time indicator, no indicator in the viewfinder is recorded.

The clock is set to East Coast Standard Time at the factory. You can reset the clock in the menu system.

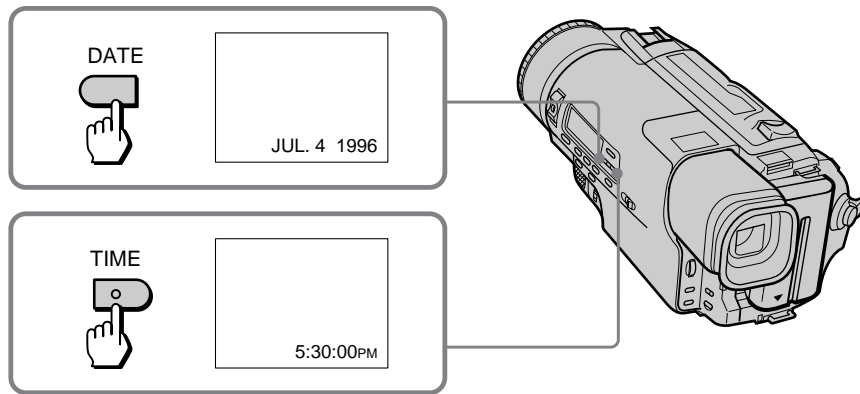

To stop recording with the date or time

Press DATE or TIME again. The date or time indicator disappears. The recording continues.

Note on the date or time indicator

If you press DATE or TIME while you are recording in CINEMA mode, the indicators in the viewfinder move upwards.

Fade-in and fade-out

You can fade in or out to give your recording a professional appearance.

When fading in, the picture gradually fades in from black or mosaic while the sound increases. When fading out, the picture gradually fades to black or mosaic while the sound decreases.

When fading in [a]

- (1) While the camcorder is in Standby mode, press FADER/OVERLAP (only for CCD-TR3300), or FADER (only for CCD-TR2300). The fade indicator starts flashing.
- (2) Press START/STOP to start recording. The fade indicator stops flashing.

When fading out [b]

- (1) During recording, press FADER/OVERLAP (only for CCD-TR3300), or FADER (only for CCD-TR2300). The fade indicator starts flashing.
- (2) Press START/STOP to stop recording. The fade indicator stops flashing, and then recording stops.

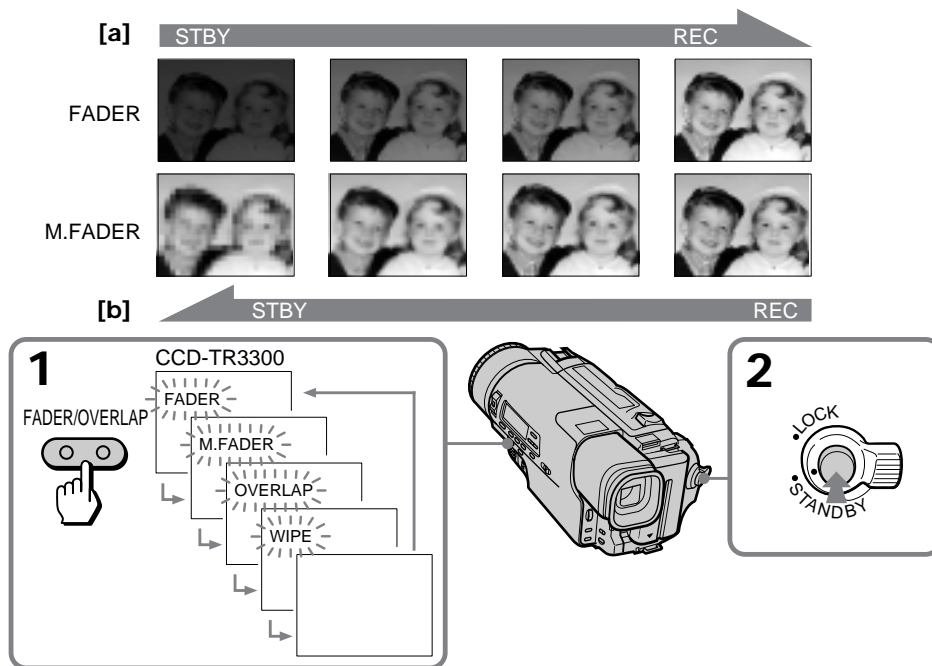

Note on fade indicator

— CCD-TR2300 only

Each time you press FADER, the fade indicator changes: FADER → M.FADER → no indicator, cyclically.

Fade-in and fade-out

To cancel the fade-in/fade-out function

Before pressing START/STOP, press FADER/OVERLAP (only for CCD-TR3300), or FADER (only for CCD-TR2300) until the fade indicator disappears.

When the date or time indicator is displayed

The date or time indicator does not fade in or fade out.

Note on fade-in/fade-out

Fade-in/fade-out function is cancelled after executing this function.

When the title is displayed

You cannot use the FADER function. When FADER is set, you cannot superimpose a title.

Overlapping two pictures (CCD-TR3300 only)

When you switch from one scene to another, you can overlap the two pictures. With this function, the first scene turns to the second one gradually.

You can hear the sound of the second scene gradually as you start recording the second scene.

- (1) While the camcorder is in Standby mode, press FADER/OVERLAP repeatedly so that the OVERLAP indicator appears in the viewfinder.
- (2) Press START/STOP to record the next scene. The OVERLAP indicator disappears after the overlapping.

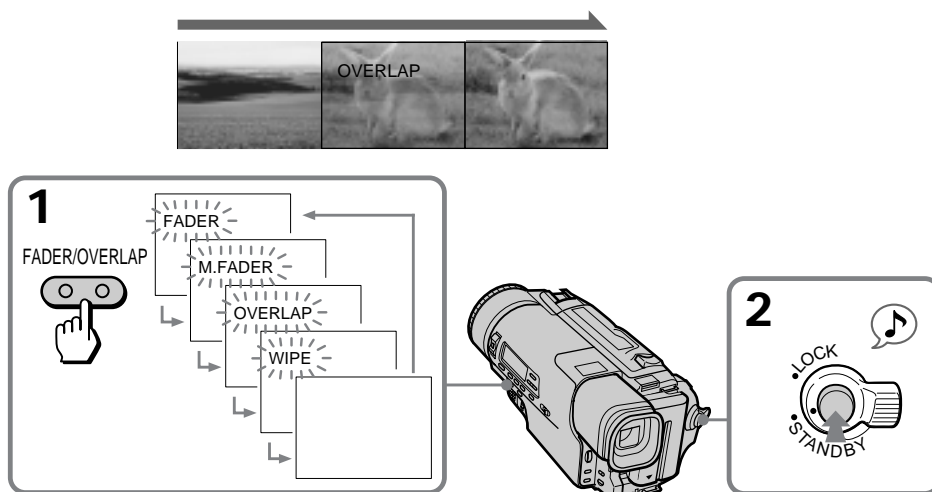

Notes on overlap

- You cannot use the following functions while using the overlap function. Also, while using the following functions, you cannot use the overlap function.
 - Digital effect
 - Slow shutter
 - Title
- When you select the overlap function after using the following operations, the camcorder memorizes the image on the tape. As the image is being memorized, the OVERLAP indicator flashes quickly, and the picture you are shooting disappears from the viewfinder. You may not record a clear picture depending on the condition of the tape.
 - Turn STANDBY down
 - Set the POWER switch to OFF
 - Eject a tape
 - Edit search
 - Fading out
 - Digital effect
 - Slow shutter
 - Title

Wiping away a still picture (CCD-TR3300 only)

When you switch from one scene to another, you can wipe away the still picture. With this function, the first still picture is wiped away from the center to reveal the moving picture underneath.

You can hear the sound of the second scene as you start recording the second scene.

- (1) While the camcorder is in Standby mode, press FADER/OVERLAP repeatedly so that the WIPE indicator appears in the viewfinder.
- (2) Press START/STOP to record the next scene. The WIPE indicator disappears after wiping away.

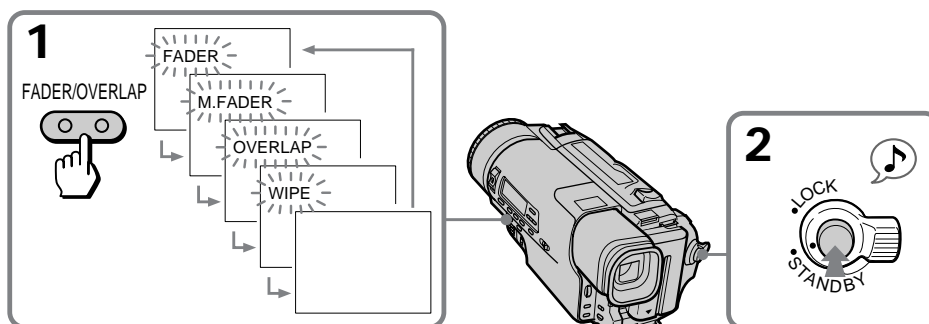

Notes on wipe

- You cannot use the following functions while using the wipe function. Also, while using the following functions, you cannot use the wipe function.
 - Digital effect
 - Slow shutter
 - Title
- You can select wipe during recording.
- When you select the wipe function after using the following operations, the camcorder memorizes the image on the tape. As the image is being memorized, the WIPE indicator flashes quickly, and the picture you are shooting disappears from the viewfinder. You may not record a clear picture depending on the condition of the tape.
 - Turn STANDBY down
 - Set the POWER switch to OFF
 - Eject a tape
 - Edit search
 - Fading out
 - Digital effect
 - Slow shutter
 - Title

Enjoying picture effect

Selecting picture effect

You can make pictures like those of television with the Picture Effect function.

[a]



[b]



[c]



[d]



[e]



[f]



MOSAIC [a]

The picture is mosaic.

SOLARIZE [b]

The light intensity is more clear, and the picture looks like an illustration.

B&W

The picture is monochrome (black and white).

SEPIA

The picture is sepia.

NEG. ART [c]

The picture is reversed.

PASTEL [d]

The contrast of the picture is emphasized, and the picture looks like an animated cartoon.

SLIM [e]

The picture expands vertically.

STRETCH [f]

The picture expands horizontally.

Enjoying picture effect

Using picture effect function

- (1) Press PICTURE EFFECT.
- (2) Turn the control dial to select the desired picture effect mode.

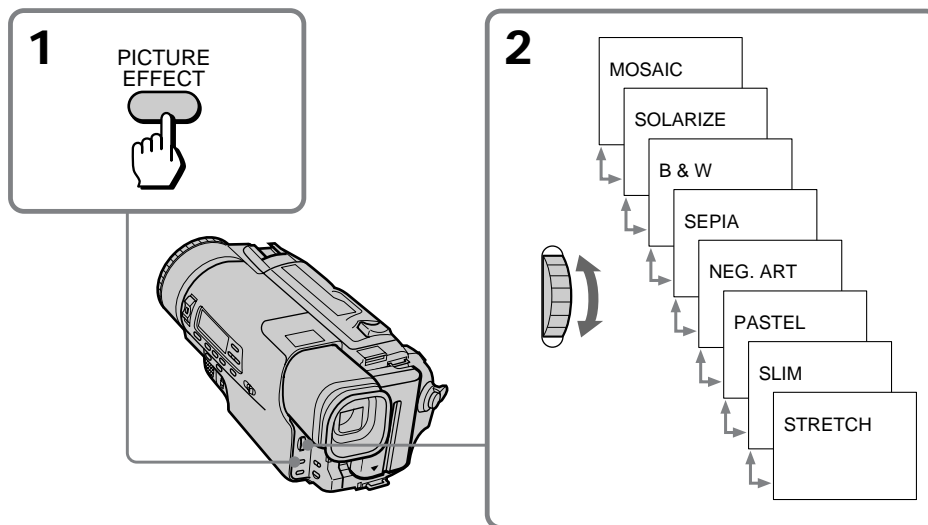

To turn off picture effect

Press PICTURE EFFECT to highlight the picture effect indicator, and press the button again. The indicator in the viewfinder goes out.

Note on the picture effect

When you turn the power off, the camcorder returns automatically to normal mode.

Recording a still picture (CCD-TR3300 only)

You can record a still picture like those of still camera or shoot a moving picture with superimposing a still picture while the sound is recorded normally.

- (1) Press DIGITAL EFFECT and turn the control dial to select the still indicator.
- (2) Press the control dial to select still mode.

The still indicator and still bars appear in the viewfinder, and still picture is stored in memory.

- (3) Turn the control dial to adjust the rate of the still picture you want to superimpose on a moving picture.

The rate of the still picture increases by the number of the still bars.

- (4) Press START/STOP to start recording a moving picture with a still picture superimpose on. When you stop recording, press START/STOP again.

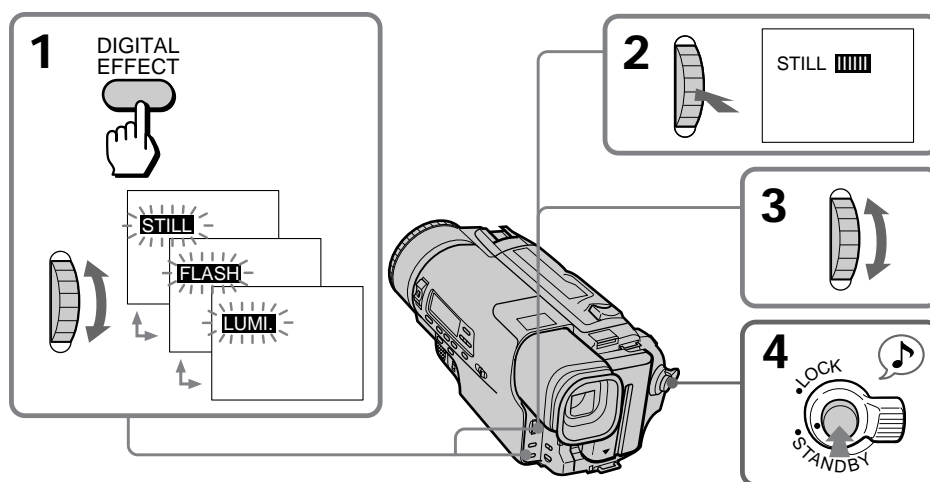

To cancel still mode

Press DIGITAL EFFECT to highlight the still indicator, and press the button again. The still indicator in the viewfinder disappears.

Notes on still mode

- You cannot use the following functions while recording a still picture.
 - Fade-in or fade-out
 - Mosaic fader
 - Overlap
 - Wipe
 - Slow shutter
- When you turn the power off, still mode will be cancelled automatically.

Recording still pictures successively (CCD-TR3300 only)

Using the Flash motion function, you can record still pictures successively at constant intervals.

You can select intervals by adjusting the flash bars with the control dial. The sound is recorded normally during Flash motion.

- (1) Press DIGITAL EFFECT and turn the control dial to select the flash motion indicator.
- (2) Press the control dial to select flash mode.
The flash motion indicator and flash motion bars appear in the viewfinder.
- (3) Turn the control dial to adjust the interval of flash motion.
- (4) Press START/STOP. Flash motion recording starts. To stop recording, press START/STOP again.

[a] normal recording

[b] flash motion recording

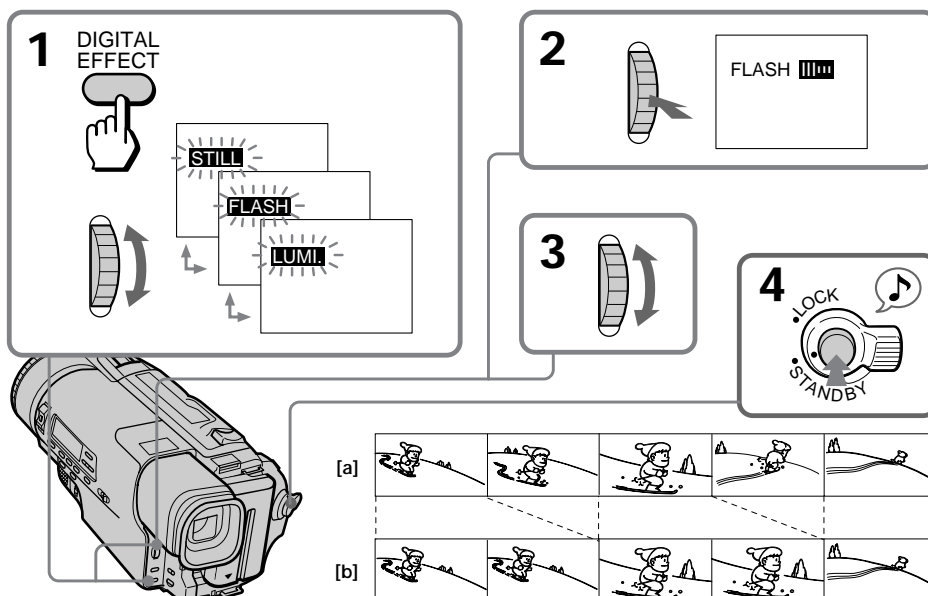

To cancel the flash motion

Press DIGITAL EFFECT to highlight the flash motion indicator, and press the button again. The flash motion indicator in the viewfinder disappears.

Notes on the flash motion

- The following functions does not work during the flash motion.
 - Fade-in or fade-out
 - Mosaic fader
 - Overlap
 - Wipe
 - Slow shutter
- When you turn the power off, flash motion mode will be cancelled automatically.

Superimposing a moving picture on a still picture (CCD-TR3300 only)

Using the Luminancekey function, you can replace a brighter color scheme portion of a still picture by a moving picture. For example, you can superimpose the favorite scene on the background if you store the picture in memory as a still picture, such as a person in the bright background. The sound is recorded normally during Luminancekey function.

- (1) Press DIGITAL EFFECT and turn the control dial to select the luminancekey indicator.
- (2) Press the control dial to select luminancekey mode.
The luminancekey indicator and the luminancekey bars appear in the viewfinder, and still picture is stored in memory.
- (3) Turn the control dial to adjust the color scheme of the still picture.
The rate of the still picture increases by the number of the luminancekey bars.
- (4) Press START/STOP. Luminancekey recording starts. To stop recording, press START/STOP again.

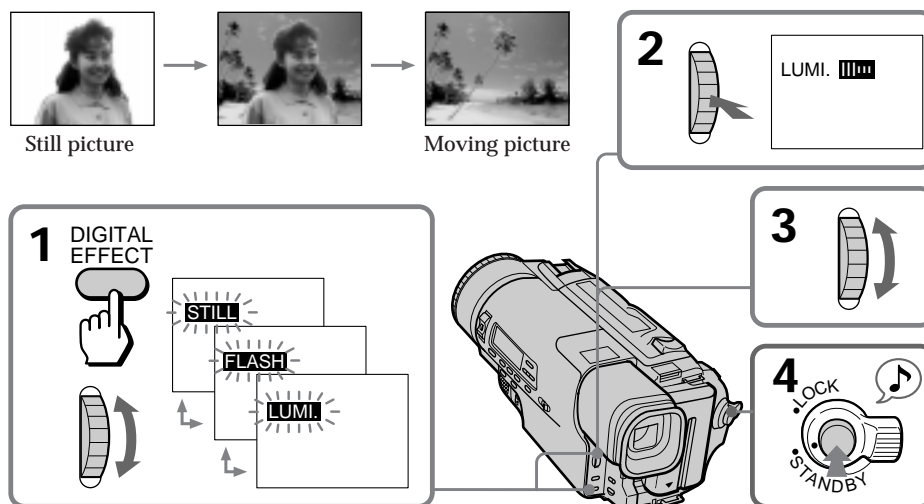

To cancel the luminancekey

Press DIGITAL EFFECT to highlight the luminancekey indicator, and press the button again. The luminancekey indicator in the viewfinder disappears.

Notes on the luminancekey

- The following functions does not work during luminancekey.
 - Fade-in or fade-out
 - Mosaic fader
 - Overlap
 - Wipe
 - Slow shutter
- When you turn the power off, luminancekey mode will be cancelled automatically.

Re-recording a picture in the middle of a recorded tape

You can insert a scene in the middle of a recorded tape by setting the starting and ending points. The previous recorded portion will be erased. If the RC time code appears in the viewfinder, set COUNTER to NORMAL in the menu system to display the tape counter.

- (1) While the camcorder is in Standby mode, keep pressing the + (forward playback) or - (reverse playback) side of EDITSEARCH, and release the button where you want to end the insertion [b]. The camcorder enters Standby mode again.
- (2) Press COUNTER RESET. The counter resets to zero.
- (3) Keep pressing the - side of EDITSEARCH and release the button at the point where you want to start the insertion [a].
- (4) Press ZERO MEM on the Remote Commander. The ZERO MEM indicator flashes.
- (5) Press START/STOP to start recording. The recording stops automatically at the counter zero point.

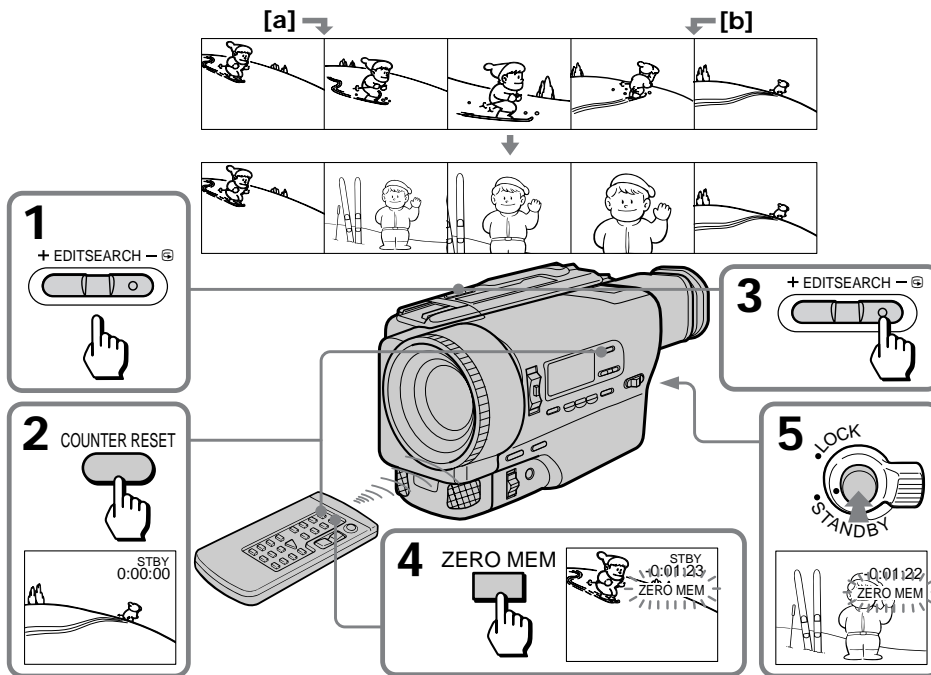

To change the end point

Press ZERO MEM to erase the ZERO MEM indicator, then repeat steps 2 to 5.

Note on re-recording

The picture and the sound may be distorted at the end of the inserted portion when it is played back.

Using the wide mode function

Selecting the desired mode

You can record a cinemalike picture (CINEMA) or a 16:9 wide picture to watch on the 16:9 wide-screen TV (16:9 FULL).

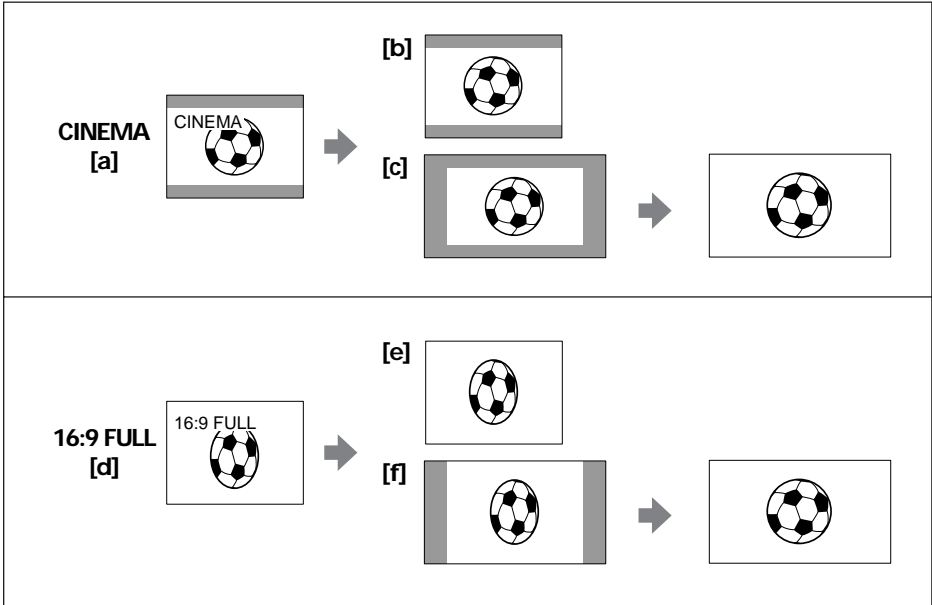

Advanced Operations

CINEMA

Black bands appear at the top and the bottom of the screen, and the viewfinder [a] and a normal TV screen [b] look wide. You can also watch the picture without black bands on a wide-screen TV [c].

16:9 FULL

The picture in the viewfinder [d] or on a normal TV [e] is horizontally compressed. You can watch the picture of normal images on a wide-screen TV [f].

Using the wide mode function

While the camcorder is in Standby mode, press 16:9WIDE repeatedly so that the desired mode indicator appears in the viewfinder.

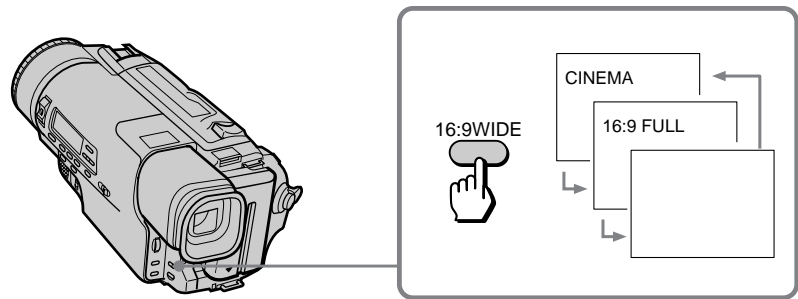

Using the wide mode function

To cancel wide mode

Press 16:9WIDE repeatedly until the wide mode indicator disappears.

To watch the tape recorded in wide mode

To watch the tape recorded in CINEMA mode, set the screen mode of the wide-screen TV to zoom mode. To watch the tape recorded in 16:9 FULL mode, set it to full mode. For details, refer to the instruction manual of your TV.

Note that the picture recorded in 16:9 FULL mode looks compressed on a normal TV.

Notes on wide mode

- When you record in 16:9 FULL mode, the date or time indicator will be widened on the wide-screen TV.
- If you dub a tape, the tape is copied in the same mode as the original recording.
- The wide mode is cancelled automatically 5 minutes after you remove the power source.

Selecting the START/STOP mode

Your camcorder has two modes besides normal start/stop mode. These modes enable you to take a series of quick shots resulting in a lively video.

(1) Set the START/STOP MODE switch to the desired mode.

: Recording starts when you press START/STOP, and stops when you press it again (normal mode).

: The camcorder records only while you press down START/STOP.

5 SEC: When you press START/STOP, the camcorder records for 5 seconds and then stops automatically.

(2) Turn STANDBY up and press START/STOP. Recording starts.

If you selected 5 SEC, five dots appear in the viewfinder. The dots disappear at a rate of one per second. When 5 seconds elapse and all the dots disappear, the camcorder switches to Standby mode automatically.

If you select , the camcorder records as long as you hold down START/STOP.

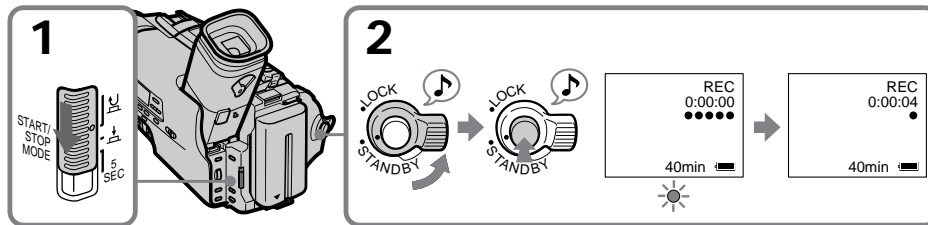

To extend the recording time in 5 SEC mode

Press START/STOP again before all the dots disappear. Recording continues for about 5 seconds from the moment you pressed START/STOP.

To return to normal recording

Set the START/STOP MODE switch to . If you set the switch while recording, recording continues.

Note on 5 SEC recording and mode

You cannot use FADER/OVERLAP (only for CCD-TR3300) or FADER (only for CCD-TR2300) if you select 5 SEC or .

Superimposing a title

You can select one of eight preset titles. You can also select the language, position, and color of titles in the menu system.

Selecting the language

- (1) While the camcorder is in Standby mode, press MENU to display the menu.
- (2) Turn the control dial to select TITLE LANG, then press the dial.
- (3) Turn the control dial to select the desired language, then press the dial.
- (4) Press MENU to erase the menu display.

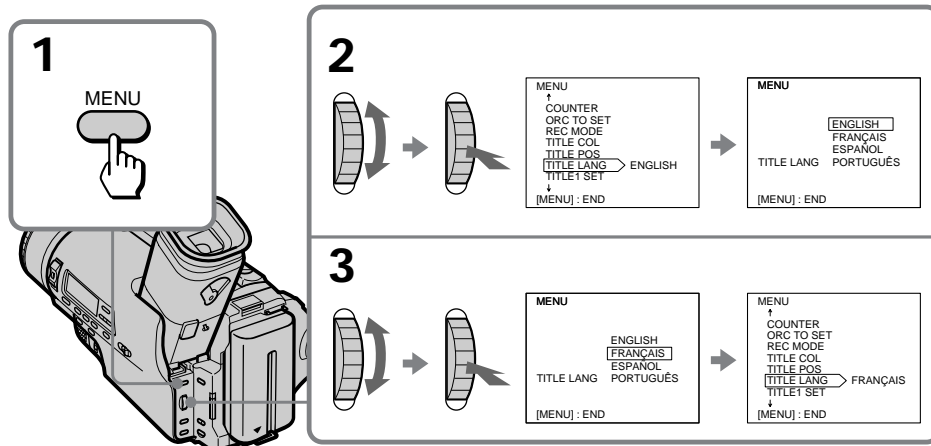

Using titles

To add the title from the beginning

- (1) While the camcorder is in Standby mode, press TITLE repeatedly until the desired title appears.

Each time a new title appears, it flashes. When the desired title appears, wait for it to stop flashing.

Titles cycle as follows.

Original title 1 → Original title 2 → HELLO! → HAPPY BIRTHDAY →
HAPPY HOLIDAYS → CONGRATURATIONS! → OUR SWEET BABY →
WEDDING → VACATION → THE END

After "THE END" the title indicator goes off once and returns to Original title 1 again.

The titles are displayed in the language you selected in the menu system.

- (2) Press START/STOP to start recording.
- (3) When you want to stop recording the title, press TITLE again.

Note on titles

The contents and the order of titles are different depending on the languages.

If you have not stored any original titles

The titles begin from "HELLO!".

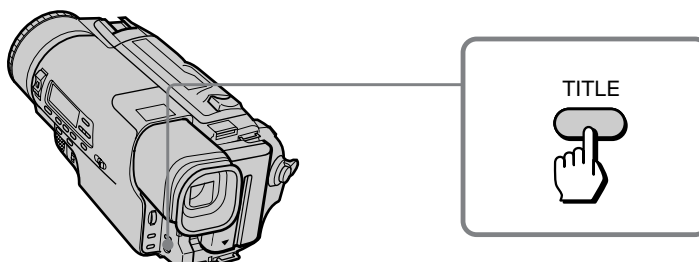

To add the title while you are recording

- (1) While in Standby mode, press TITLE repeatedly until the desired title appears to cycle through the titles.

Each time a new title appears, it flashes.

- (2) When the desired title appears, wait for it to stop flashing, and press TITLE again to erase the title from the display.
- (3) Start recording.
- (4) When you reach the point where you want to add the title, press TITLE.
- (5) When you want to stop recording the title, press TITLE again.

Superimposing a title

To select the color of the title

- (1) While in Standby mode, press MENU to display the menu.
- (2) Turn the control dial to select TITLE COL and press the control dial to select it.
The color menu appears.
- (3) Turn the control dial to highlight a color, and press the control dial to select it.
- (4) Press MENU to erase the menu display.

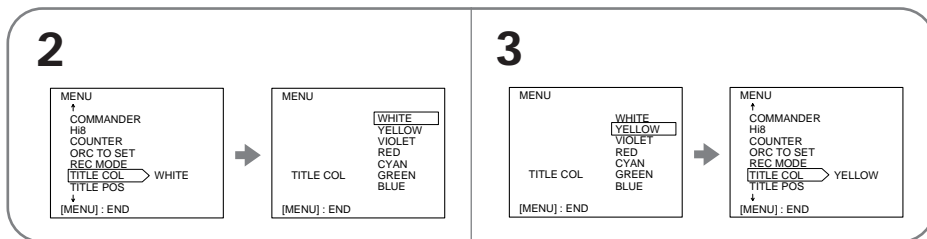

To select the position of the title

- (1) While in Standby mode, press MENU to display the menu in the viewfinder.
- (2) Turn the control dial to select TITLE POS and press the control dial to select it.
The position menu appears.
- (3) Turn the control dial to highlight CENTER or BOTTOM, and press the control dial to select it.
- (4) Press MENU to erase the menu display.

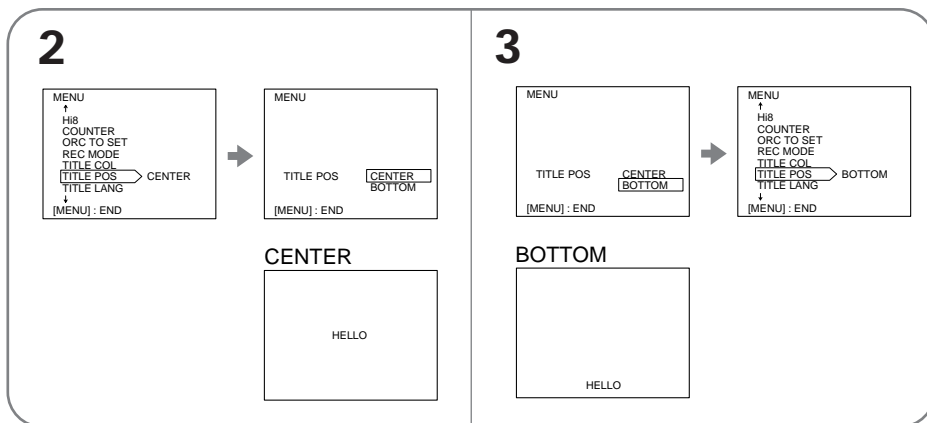

Notes on selecting a title

- You cannot select a title while you are recording.
- You cannot select fade-in/fade-out while you are adding a title.
- You cannot record a title while you are recording with the date or time.

Making your own original titles

You can make up to two titles and store them in the camcorder.

Eject the cassette before you begin. Your title can have up to 22 letters.

- (1) While in Standby mode, press MENU to display the menu.
- (2) Turn the control dial to select TITLE 1 SET or TITLE 2 SET, then press the dial.
- (3) Turn the control dial to highlight a letter, and press the control dial to select it.
- (4) Repeat step 3 until you finish the title.
- (5) When you are finished, turn the control dial to highlight \leftarrow and press the control dial to select it.

The title is stored.

- (6) Press MENU to erase the menu display.

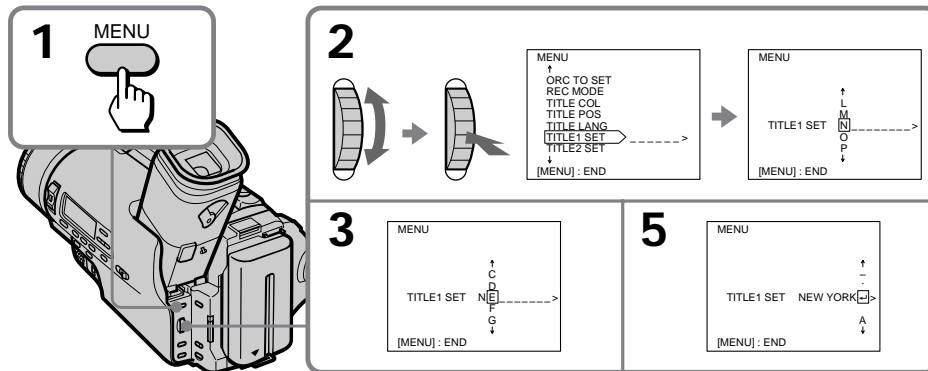

To edit a title you have stored

In step 2, select TITLE 1 SET or TITLE 2 SET, whichever title you want to edit is stored in. Then change the title.

Instead of selecting \leftarrow in step 5 to store the title

You can do one of the following:

- Enter 22 letters.
- Press MENU.

If you do nothing more than 5 minutes

The power goes off automatically. Turn STANDBY down once, turn it again up and proceed from step 3.

To delete a title

At the leftmost character position, select \leftarrow and press TITLE. Do not erase the title by selecting empty spaces. If you do so, a title full of empty spaces is stored.

Releasing the STEADY SHOT function

When you shoot, the  indicator appears in the viewfinder. This indicates that the Steady Shot function is working and the camcorder compensates for camera-shake.

Set STEADY SHOT to OFF.

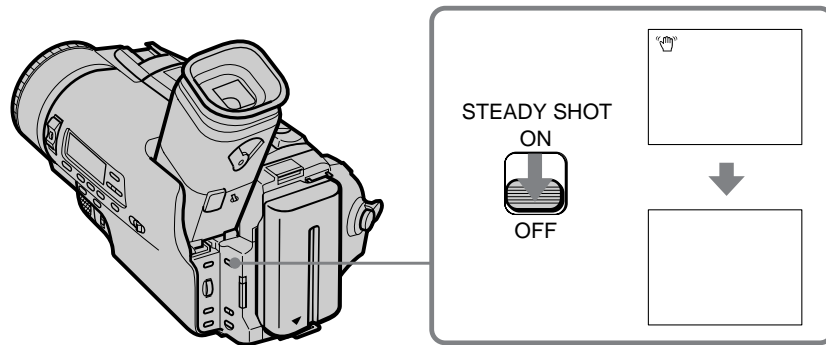

To activate the Steady Shot function again

Set STEADY SHOT to ON.

Notes on the Steady Shot function

- The Steady Shot function will not correct excessive camera-shake.
- If you install a wide conversion lens (not supplied), the camcorder may cause minor shading when STEADY SHOT is set to ON. In this case, set STEADY SHOT to OFF.

Checking the tape condition before recording (ORC)

Use this feature to check the tape condition before recording, so that you can get the best possible picture.

- (1) While in Standby mode, press MENU to display the menu.
- (2) Turn the control dial to highlight ORC TO SET and press the control dial to select it.

“START/STOP KEY” appears.

- (3) Press START/STOP.

The camcorder takes about 5 seconds to check the condition of the tape head and the cassette.

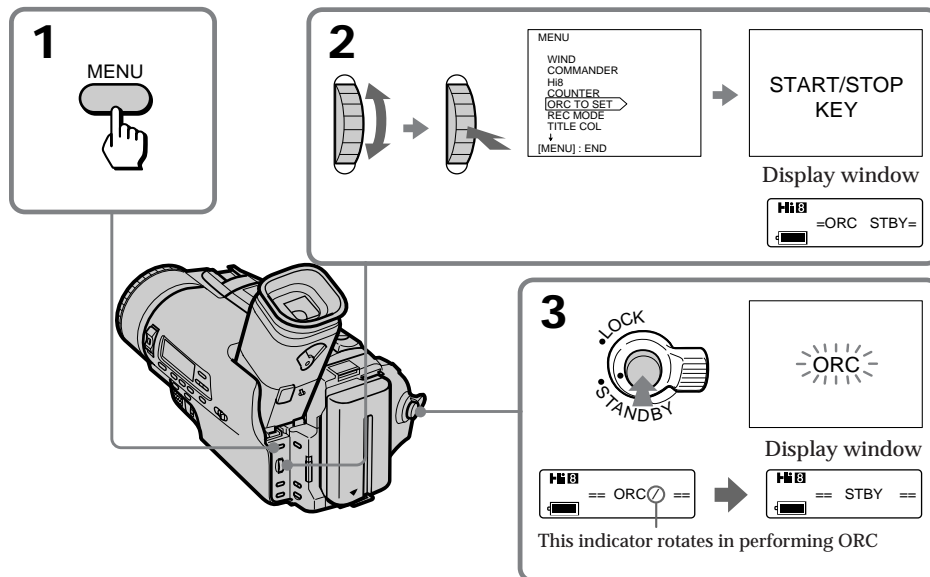

Each time you insert the cassette

Perform the above procedures.

To see if you have performed ORC

Perform steps 1 and 2 above. If “ORC ON” is displayed, the tape condition has been checked.

When the tab on the cassette exposes the red mark

You can not use ORC.

Note on ORC TO SET setting

When you set ORC TO SET, the recording on the tape is erased for about 0.1 second so that the camcorder can check the tape condition. Be careful when you use a recorded tape. The 0.1 second blank is erased if you record from the point where you set ORC TO SET for more than 2 seconds, or if you record over the blank. You cannot set ORC TO SET for a cassette with its tab out (red).

Selecting automatic/manual adjustment modes

The camcorder's automatic functions offer you worry-free operation under most shooting conditions. But in some circumstances, manual adjustment is better for creative recording.

You can adjust focus, aperture, shutter speed, gain, and white balance automatically or manually. Also, you can use the PROGRAM AE function in particular circumstances, and adjust the brightness of the picture with the AE shift function.

Here's the overview of each manual adjustment. See the following pages for detailed information.

To focus manually

Set FOCUS to MANUAL. You can adjust the focus regardless of the position of the AUTO LOCK/HOLD switch. When you want to focus automatically, set FOCUS to AUTO.

To manually adjust aperture, shutter speed, gain, and white balance

Set AUTO LOCK/HOLD to the center position. You can adjust each item independently. When you want to adjust each item automatically, set AUTO LOCK/HOLD to AUTO LOCK.



To manually adjust the brightness

Use AE SHIFT in the menu system.

Note on the previous settings

Once you adjust the settings manually, they are stored in memory in the following cases as long as the lithium battery is in place.

- when you return to automatic adjustment mode.
- when you set the POWER switch to OFF.
- in five minutes after you remove the power source as long as the lithium battery is installed in the camcorder.

	Automatic adjustment	PROGRAM AE			Manual adjustment
		Aperture priority mode	Shutter priority mode	Twilight mode	
Aperture	Automatic	Manual	Automatically adjusted according to the shutter speed	Automatic	Automatic or manual
Shutter speed	1/60	Automatically adjusted according to the aperture	Manual	1/60	1/60 or manual
Gain	Automatic	Automatic	Automatic	Automatic	Automatic or manual
White balance	Automatic	Changes each time you turn the control dial after pressing WHT BAL Automatic (no indication) or  (one push white balance) \leftrightarrow  (outdoor) \leftrightarrow  (indoor)			
AE shift*	Effective	Effective	Effective	Effective	Effective
Focus	Automatic or manual according to the position of the FOCUS switch				

* You cannot change AE shift while adjusting the aperture manually.

Focusing manually

When to use manual focus

In the following cases you should obtain better results by adjusting the focus manually.

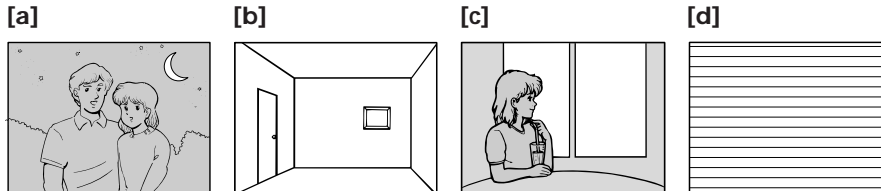

- Insufficient light [a]
- Subjects with little contrast – walls, sky, etc. [b]
- Too much brightness behind the subject [c]
- Horizontal stripes [d]
- Subjects through frosted glass
- Subjects beyond nets, etc.
- Bright subject or subject reflecting the light
- Shooting a stationary subject when using a tripod

Focusing manually

When focusing manually, first focus in telephoto before recording, and then reset the shot length.

- (1) Set FOCUS to MANUAL. The  indicator appears in the viewfinder.
- (2) Move the power zoom lever to the “T” side until the lever reaches the end.
- (3) Turn the focus ring to achieve a sharp focus. Be sure to not touch the built-in microphone when you turn the focus ring.
- (4) Set the desired shot length using the power zoom lever.

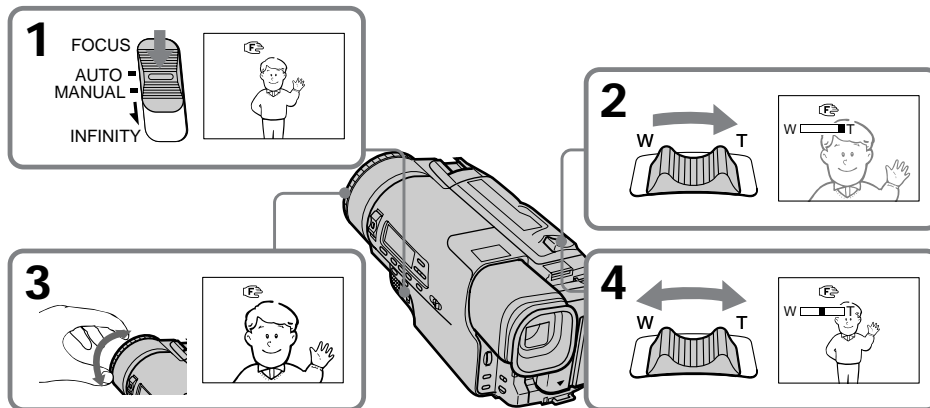

Focusing manually

To return to autofocus mode

Set FOCUS to AUTO. The  indicator in the viewfinder disappears.

Shooting in relatively dark places

Shoot at wide-angle after focusing in the telephoto position.

Note on the focus ring

The focus ring does not have a stop position.

To shoot with autofocus momentarily

When you want to switch to autofocus momentarily while recording in manual focus mode, press PUSH AUTO down. Autofocus functions while PUSH AUTO is held down. When it is released, manual focus mode will be resumed.

To record a very distant subject



Push FOCUS down to INFINITY. The lens focuses on the most distant subject while FOCUS is held down.

When it is released, manual focus mode is resumed.

Use this function when shooting through a window or a screen, to focus on a more distant subject.

Note on manual focusing

The  indicator will change to the followings:

- : When recording an infinitely distant subject.
- : When there is something too close to focus on.

Using the PROGRAM AE function

About the PROGRAM AE function

You can select from three PROGRAM AE modes to fit the shooting situation. Set AUTO LOCK/HOLD to the center position. Press PROGRAM AE, then select the desired mode by turning the control dial. Each time you turn the dial, the indicator in the viewfinder changes: **AE** A (Aperture Priority) ↔ **AE** S (Shutter Priority) ↔ ☾ (Twilight).

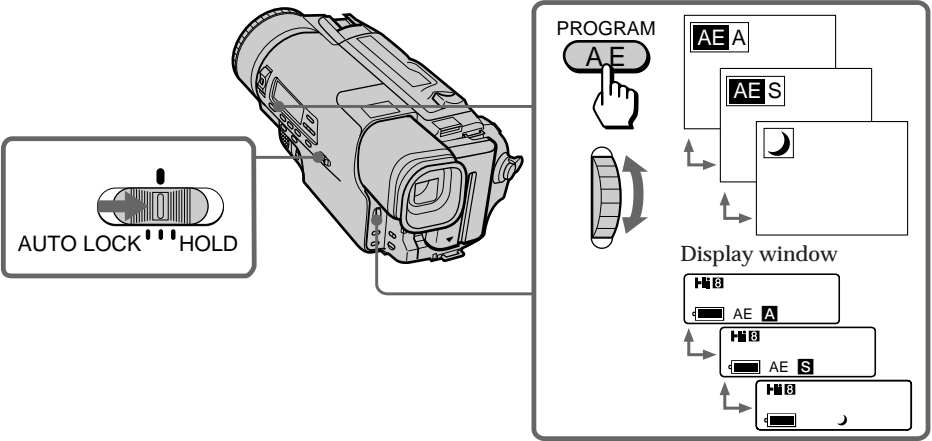

Advanced Operations

Note on recording in PROGRAM AE
We recommend that you adjust the focus and white balance manually.

Using the aperture priority mode

You can select the aperture to determine the desired depth of focus field. The shutter speed is automatically set (between 1/60 and 1/2000) according to the aperture value to maintain appropriate exposure.

- (1) Set AUTO LOCK/HOLD to the center position.
- (2) Press PROGRAM AE so that the indicator appears in the viewfinder.
- (3) Turn the control dial to select **AE** A, then press the dial.
- (4) Turn the control dial to select the desired aperture value. You can select from the following 15 values: F1.6, F2, F2.4, F2.8, F3.4, F4, F4.8, F5.6, F6.8, F8, F9.6, F11, F14, F16, F19. For a smaller aperture, select a higher value.

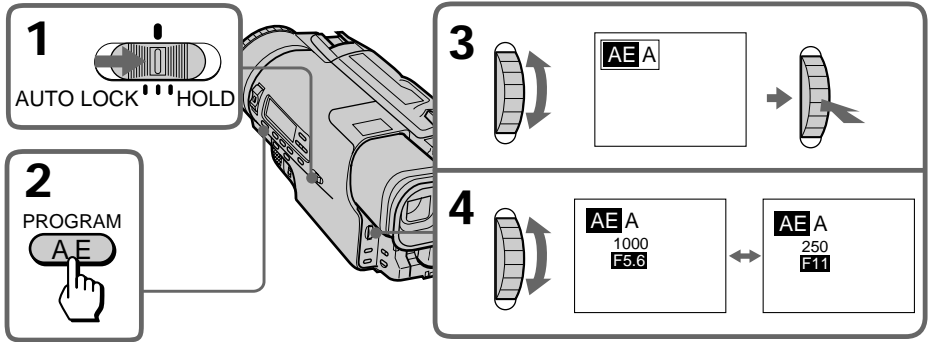

Using the PROGRAM AE Function

To return to automatic adjustment mode

Set AUTO LOCK/HOLD to AUTO LOCK, or press PROGRAM AE so that no indicator appears in the viewfinder.

About the depth of focus field

The depth of focus field is the in-focus range measured from the distance behind a subject to the distance in front. The depth of focus field can vary with the aperture value and the focal length. Lowering the F value (larger aperture) reduces the depth of focus field. Raising the F value (smaller aperture) provides a larger depth of focus field. Zooming in telephoto position offers a smaller depth of focus field while the depth of focus field in wide-angle position is greater.

Using the shutter priority mode

You can select the shutter speed between 1/60 and 1/10000. When you select a faster shutter speed, movement appears clearer with less shaking. The aperture value is automatically adjusted according to the selected shutter speed to maintain appropriate exposure. This mode is most effective when you shoot the picture with high-speed movement.

Note that the shutter speed is indicated in the viewfinder as, for example, "100" for 1/100 shutter speed.

- (1) Set AUTO LOCK/HOLD to the center position.
- (2) Press PROGRAM AE so that the indicator appears in the viewfinder.
- (3) Turn the control dial to select **AE S**, then press the dial.
- (4) Turn the control dial to select the desired shutter speed. You can select from the following 16 speeds: 1/60, 1/90, 1/100, 1/125, 1/180, 1/250, 1/350, 1/500, 1/725, 1/1000, 1/1500, 1/2000, 1/3000, 1/4000, 1/6000, 1/10000. For a faster shutter speed, select a larger value indicator in the viewfinder.

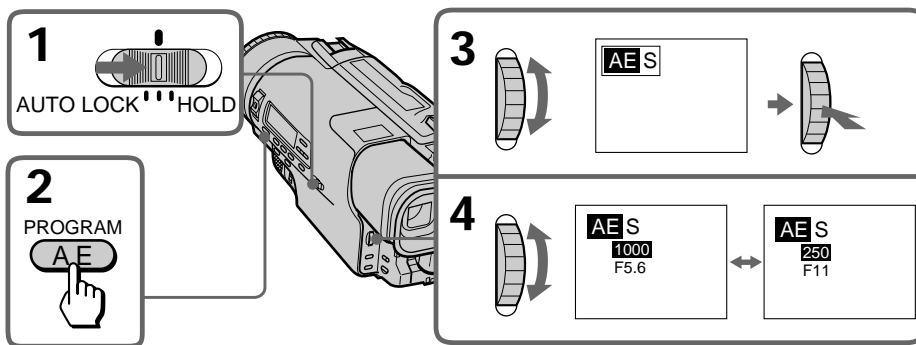

To return to automatic adjustment mode

Set AUTO LOCK/HOLD to AUTO LOCK, or press PROGRAM AE so that no indicator appears in the viewfinder.

When the aperture value is automatically adjusted to F1.6

We recommend shooting in sunlight or using a video light (not supplied).

When shooting a very bright subject

A vertical band (smear) may appear on the screen if the shutter speed is set too high.

To select the best shutter speed

Subject	Shutter speed
<ul style="list-style-type: none"> • A golf swing or tennis match in fine weather (to view the hit ball clearly in still picture mode, set to 1/1000 to 1/4000) 	1/725 - 1/10000
<ul style="list-style-type: none"> • A landscape shot from a moving car • A moving roller coaster in overcast days • An athletic scene, marathon, etc. 	1/125 - 1/500
<ul style="list-style-type: none"> • Indoor sports • Replacement for the ND2 filter (to have the exposure) • Recording pictures with less flicker under a fluorescent lamp 	1/100
<ul style="list-style-type: none"> • In sunny weather (to avoid an out-of-focus picture due to a small aperture) 	1/90

Using the twilight mode

You can record a bright subject in a dark place without ruining the atmosphere. The aperture is automatically adjusted to maintain the appropriate exposure. The shutter speed is fixed at 1/60. This mode is effective when you record night views, neon signs or fireworks.

- (1) Set AUTO LOCK/HOLD to the center position.
- (2) Press PROGRAM AE so that the indicator appears in the viewfinder.
- (3) Turn the control dial to select ☾ indicator.

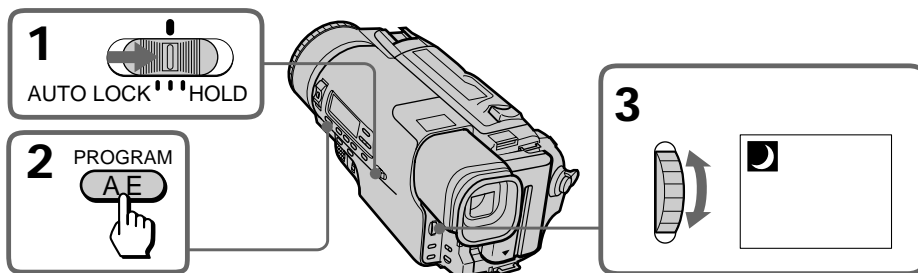
**To return to automatic adjustment mode**

Set AUTO LOCK/HOLD to AUTO LOCK, or press PROGRAM AE so that no indicator appears in the viewfinder.

When shooting an excessively bright subject

Autofocus may not work effectively. Focus manually then.

Using manual mode

The manual mode features an advanced recording technique by controlling the exposure with a combination of adjustments of the aperture value, shutter speed and gain level.

When to use manual mode

[a]



[b]



[c]



[d]



- When the background is too bright (backlighting) [a], open the aperture (lower F value).
- When the subject is bright with dark background [b], close the aperture (higher F value).
- When the subject moves at high speed [c], set the shutter speed value faster.
- When a dark scene is shot overexposed [d], lower the gain.

Item		Selectable steps	Variation of exposure	Brighter ↔ Darker
Aperture		16 steps	0.5 EV	F1.6 ↔ F19 (CLOSE)
Shutter speed		Fast: 16 steps	0.5 EV	1/60 ↔ 1/10000
	CCD-TR3300 only	Slow: 4 steps	1.0 EV	1/4 ↔ 1/30
Gain		8 steps	0.5 EV	+18 dB ↔ -3 dB

Note on recording in manual mode

We recommend that you adjust the focus and white balance manually.

Shooting in manual mode

In manual mode, you can adjust the aperture, shutter speed and gain independently. Use the graph on page 58 for your reference to set a value of each item.

- (1) Set AUTO LOCK/HOLD to the center position.
- (2) Press the button of the item you want to adjust (IRIS, SHUTTER SPEED, or GAIN).
- (3) Turn the control dial to adjust the selected item.

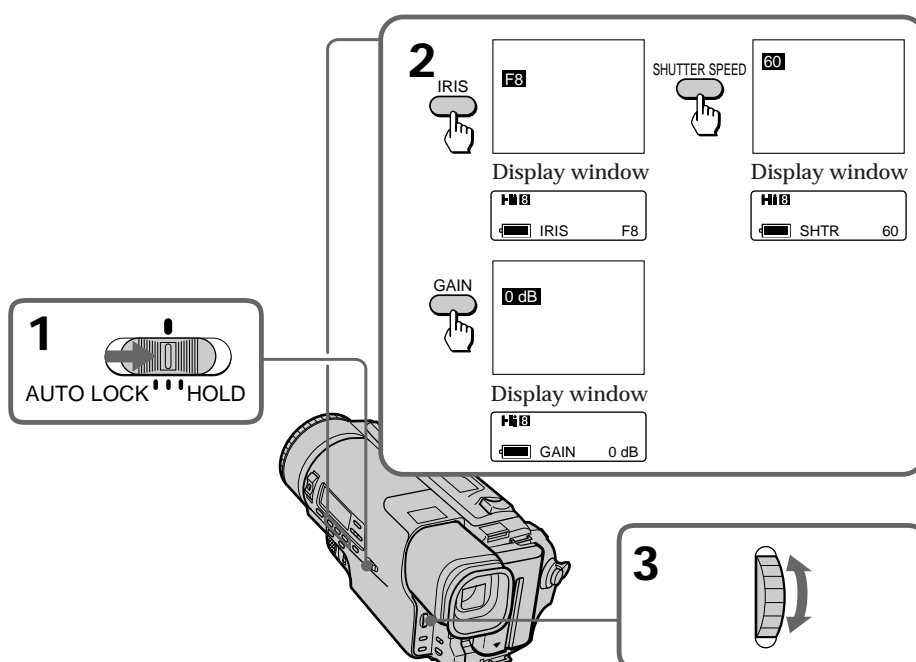

Adjustment of each item

To adjust the aperture

You can select the aperture from the following 16 values: F1.6, F2, F2.4, F2.8, F3.4, F4, F4.8, F5.6, F6.8, F8, F9.6, F11, F14, F16, F19, CLOSE. To open the aperture (larger aperture), select a lower value.

To adjust the shutter speed

You can select the shutter speed from the following 20 (CCD-TR3300), or 16 (CCD-TR2300) speeds:

— CCD-TR3300:

1/4, 1/8, 1/15, 1/30, 1/60, 1/90, 1/100, 1/125, 1/180, 1/250, 1/350, 1/500, 1/725, 1/1000, 1/1500, 1/2000, 1/3000, 1/4000, 1/6000, 1/10000.

— CCD-TR2300:

1/60, 1/90, 1/100, 1/125, 1/180, 1/250, 1/350, 1/500, 1/725, 1/1000, 1/1500, 1/2000, 1/3000, 1/4000, 1/6000, 1/10000.

To increase the shutter speed, select a smaller setting (larger value indicator in the viewfinder).

Using manual mode

To adjust the gain

You can select the gain from the following 8 levels: -3 dB, 0 dB, +3 dB, +6 dB, +9 dB, +12 dB, +15 dB, +18 dB. To increase the gain to brighten the picture, select a higher level.

If you adjusted the aperture manually prior to adjusting the gain, the gain level is set according to the aperture setting.

To change the setting

Press the button of the item you want to change so that the selected item indicator highlights in the viewfinder. Turn the control dial to change to the desired setting.

To lock the manual settings

After adjusting the setting, set AUTO LOCK/HOLD to HOLD. The IRIS, SHUTTER SPEED, GAIN, WHT BAL buttons and the control dial do not work in these manual settings.

To return to automatic adjustment mode

Press repeatedly the button of the item you want to return to automatic adjustment mode until the indicator disappears in the viewfinder. To return all the items to automatic mode, set AUTO LOCK/HOLD to AUTO LOCK.

Note on gain level

When you select a gain level that is too high, the picture may be distorted.

Using slow shutter (CCD-TR3300 only)

If you want to record a dark picture brightly, or represent the movement of the subject lively, set the shutter speed to 1/30, 1/15, 1/8 or 1/4 (Slow shutter).

(1) Set AUTO LOCK/HOLD to the center position.

(2) Press SHUTTER SPEED.

The shutter speed value indicator appears in the display.

(3) Turn the control dial to select the desired shutter speed (1/30, 1/15, 1/8 or 1/4). As the indicator in the viewfinder becomes smaller, the shutter speed becomes slower.

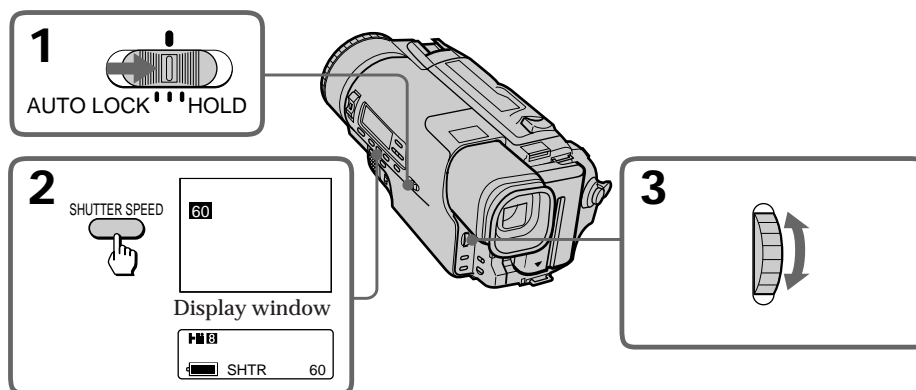

To return to automatic adjustment mode

Press SHUTTER SPEED repeatedly until the shutter speed value indicator disappears in the viewfinder.

When recording with slow shutter function

- You cannot use flash motion, overlap, wipe, still or luminancekey function.
- Autofocus may not be effective. Focus manually using a tripod.

Tips for manual adjustment

When you shoot in manual adjustment mode, we recommend you to keep the exposure fixed to make a clear picture. This section shows you what the exposure is and how to adjust each item with the exposure fixed.

Understanding the exposure

Exposure is determined by aperture, shutter speed and gain, and is measured in EV (exposure value) as shown below.

$$\begin{aligned} \text{Total EV} = & \text{EV from aperture control} \\ & + \text{EV from shutter speed control} \\ & + \text{EV from gain control} \end{aligned}$$

The total exposure value can be varied or maintained at a constant level by controlling the aperture, gain and shutter speed.

Use the following graph to select the setting. One scale corresponds to 0.5 EV.

[a] Vertical axis: Aperture value (F value)

[b] Horizontal axis: Shutter speed (per second)

[c] Diagonal axis: Gain level (dB)

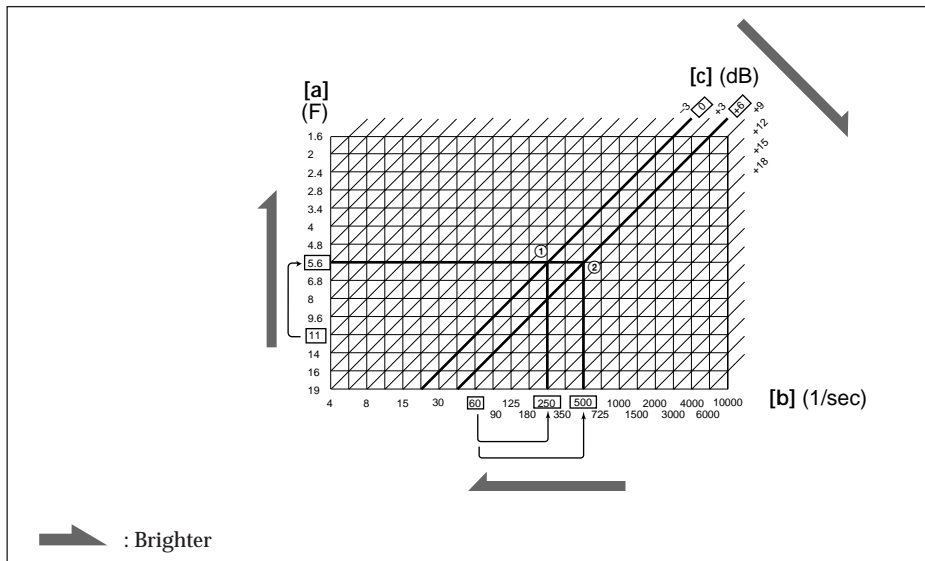

Creating a desired picture without changing the exposure

When the aperture value is F11, the shutter speed is 1/60, and the gain level is 0 dB, adjust the aperture value manually to F5.6, as an example. If you change the aperture value from F11 to F5.6 in the above example, the exposure from aperture control becomes brighter by +2 EV. Adjust the shutter speed and the gain so that the exposure becomes darker by -2 EV to not change the total exposure.

Example 1: changing only the shutter speed

To reduce the exposure by -2 EV using the shutter speed, you should change the shutter speed from 1/60 to 1/250 (①). (5 steps increase)

Example 2: setting the shutter speed to 1/500 and changing the gain level

When the shutter speed is changed from 1/60 to 1/500, the EV from the shutter speed control changes to -3 EV. To maintain total exposure, +1 EV (2 steps) should be added by increasing the gain level. Change the gain level from 0 dB to +6 dB (②). Note that when you set the gain level higher, the picture may be distorted.

Notes on manual adjustment

- When recording outdoors, the brightness of a subject may be affected by weather.
- When recording conditions change, we recommend that you reset each item.

Shooting with backlighting

When you shoot a subject with the light source behind the subject or a subject with a light background, use the BACK LIGHT function.

Press BACK LIGHT. The  indicator appears in the viewfinder.

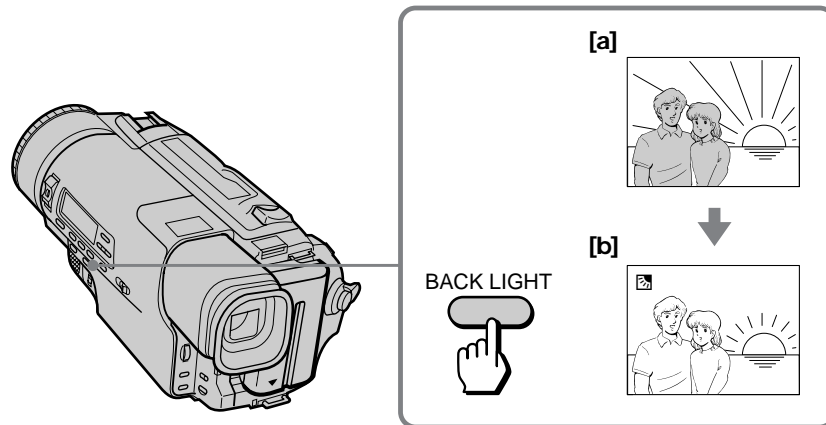

[a] Subject is too dark because of backlight.

[b] Subject becomes bright with backlight compensation.

After shooting

Be sure to release this adjustment condition by pressing BACK LIGHT again. The  indicator disappears. Otherwise, the picture will be too bright under normal lighting conditions.

This function is also effective under following conditions:

- On snow, e.g. at a ski resort
- At the beach under strong sunshine
- A subject with a light source nearby or a mirror reflecting light
- A white subject against a white background. Especially when you shoot a person wearing shiny clothes made of silk or synthetic fiber, his or her face tends to become dark if you do not use this function.

Note on the backlight function

If you press IRIS, SHUTTERSPEED or GAIN, the backlight function is cancelled.

Adjusting the brightness of the picture

When you shoot in a snowfield or on a beach in the mid-summer and the subject may become dark because of the extreme brightness, you can change the brightness of the picture in the menu system. You can also use this function when the subject is too bright — subjects on stages, night views, etc.

- (1) While the camcorder is in Standby mode, press MENU to display the menu in the viewfinder.
- (2) Turn the control dial to select AE SHIFT, then press the control dial.
- (3) Turn the control dial to adjust the brightness of the picture. The picture becomes brighter when you turn the control dial up, and darker when you turn the control dial down. (Three levels for each direction.)
- (4) Press MENU. The menu display disappears and the AE shift indicator appears in the viewfinder.

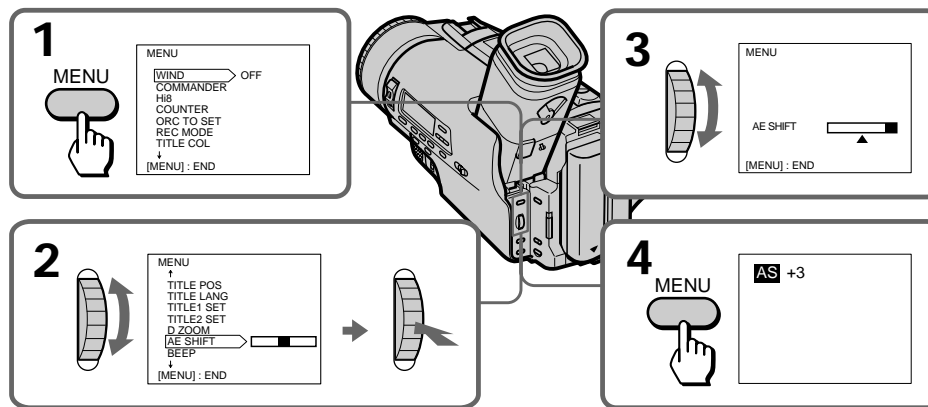

To cancel the AE shift

Set AE SHIFT to the center position in the menu system.

When adjusting the brightness

We recommend you to connect the camcorder to a TV so that you can monitor the brightness on the TV.

Note on the AE shift

You cannot change AE shift while adjusting the aperture manually.

Adjusting the white balance

White balance is the adjustment to make white subjects look white and to obtain a more natural color balance.

Selecting the appropriate mode

Select the appropriate white balance mode under the following conditions:

[a]



[b]



[c]

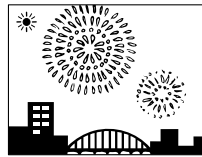

[d]

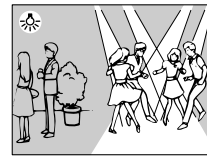

One push white balance mode

- Shooting with the lighting condition on the subject set and with the white balance set in a particular condition
- Monochromatic subject or background [a]

Outdoor mode

- Under a color matching fluorescent lamp
- Recording a sunset/sunrise, just after sunset, just before sunrise [b], neon signs, or fireworks [c]

Indoor mode

- Lighting condition changes quickly. [d]
- Too bright place such as photography studios
- Under sodium lamps or mercury lamps

When you shoot under a fluorescent lamp, however, we recommend you to adjust the white balance automatically. You may not get an appropriate white balance when you record in the indoor mode.

Setting the white balance mode

- (1) Set AUTO LOCK/HOLD to the center position.
- (2) Press WHT BAL so that the white balance indicator appears in the viewfinder.
- (3) Turn the control dial to select the desired mode.

When you select one push white balance mode, press the control dial after selecting the one push white balance indicator.

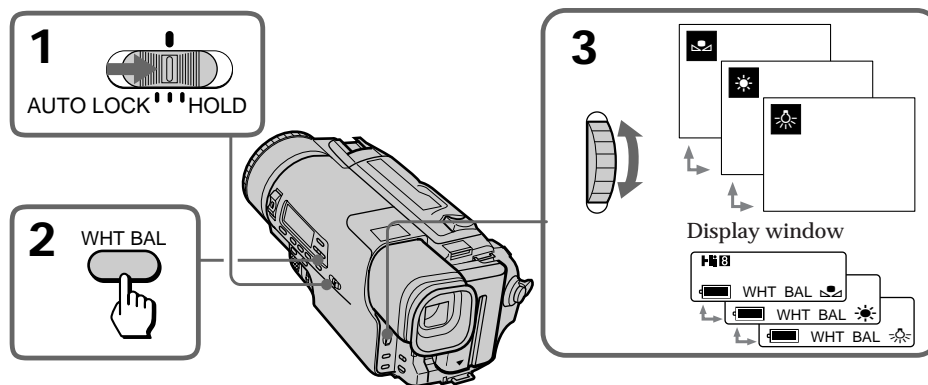

To return to automatic white balance mode

Press WHT BAL so that the white balance indicator disappears, or set AUTO LOCK/HOLD to AUTO LOCK.

When the light source changes

Adjust the white balance again. You cannot select the one push white balance mode when you are recording.

- When you record in manual adjustment mode, set AUTO LOCK/HOLD to AUTO LOCK once, then set it to the center position again.
- When you record in automatic adjustment mode, or when you replace the battery pack, point the lens toward a white object for approx. 10 seconds, then start recording.

Adjusting white balance manually (One push white balance mode)

You can set the white balance for a particular lighting condition manually. When the white balance is set manually, the colors of the object being shot will continue to look natural as long as the lighting conditions remain the same.

When a particular color is shot under different lighting sources, the color often seems to change color. When shooting subjects under changing lighting conditions, set the white balance to the AUTO mode; the subject colors will remain consistent even under changing lighting conditions.

Adjusting the white balance

- (1) Set AUTO LOCK/HOLD to the center position.
- (2) Press WHT BAL, then turn the control dial to select one push white balance indicator.
- (3) Attach the supplied white lens cap and point the camcorder at a subject if you are shooting outdoors or at a source of light if shooting indoors.
- (4) Press the control dial.

The one push white balance indicator starts to flash quickly. Once the white balance is set, the indicator stops flashing.

When you are shooting under studio lighting or a video light, we recommend you to record in indoor mode.

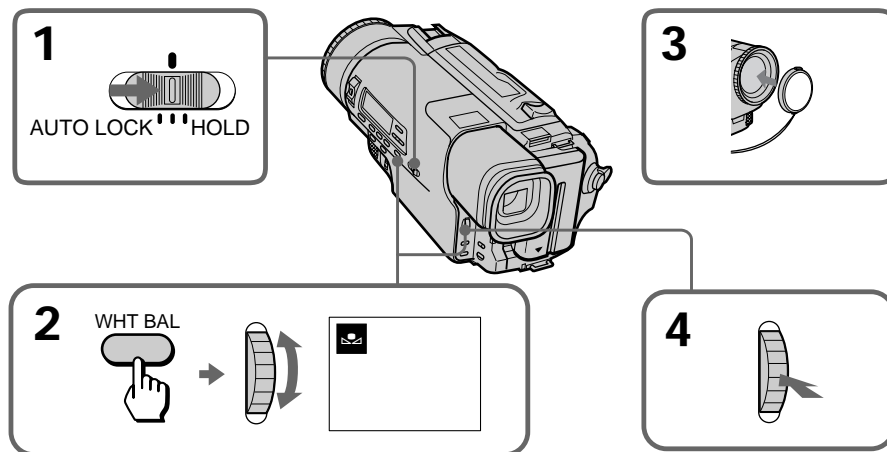

To return to automatic white balance adjustment mode

Press WHT BAL so that the one push white balance indicator disappears in the viewfinder.

Note on the one push white balance mode indicator

Slowly flashing indicator: white balance has not been set.

Quickly flashing indicator: white balance is being adjusted with the control dial.

Lighting: white balance has been set.

Note on the one push white balance mode setting

The white balance setting for one push white balance mode is retained even when you turn the power off or change white balance mode, as long as the power source is installed in the camcorder. The setting is retained for about 1 hour even when you disconnect the power source if the lithium battery is installed in the camcorder.

If the one push white balance indicator does not stop flashing when you press the control dial

The lighting is probably insufficient or you have forgotten to put the white lens cap on. If this appears to be the case, increase the lighting or attach the white cap and try again. If the indicator still continues to flash after trying this, press WHT BAL to set the camcorder to the automatic white balance mode (no indicator) or set AUTO LOCK/HOLD to AUTO LOCK.

Searching the boundaries of recorded date

You can search for the boundary between recording dates using the Date Code automatically recorded on the tape.

There are two modes:

- Searching for the beginning of a specific date, and playing back from there (**Date Search**)
- Searching for the beginning of all days, one after another, playing back about 10 seconds of each (**Date Scan**)

Each time you press DATE SEARCH, the mode changes as follows:

Date Search → Date Scan → nothing

To search for the beginning of a specific date

- (1) Set the POWER switch to VTR. The tape transport buttons light up.
- (2) Press DATE SEARCH on the Remote Commander.
- (3) When the current position is [b], press ◀◀ to search towards [a] or press ▶▶ to search towards [c].

To scan the beginning of all days

- (1) Set the POWER switch to VTR.
- (2) Press DATE SEARCH on the Remote Commander twice.
- (3) Press ◀◀ or ▶▶. Date Scan starts.

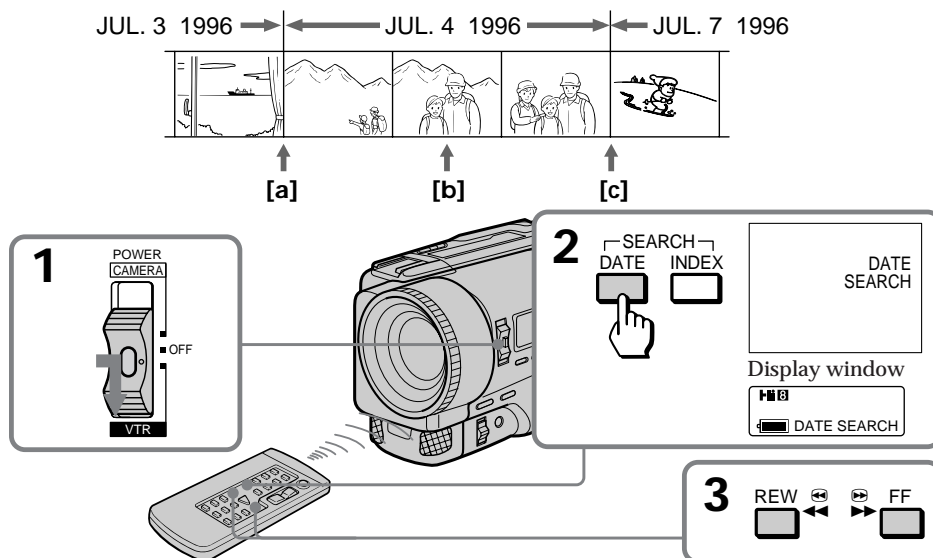

To stop searching or scanning

Press one of the following tape transport buttons: ▷, □, ◀◀ or ▶▶.

To view pictures during searching or scanning

Press ▷ and then press ◀◀ or ▶▶.

Searching the boundaries of recorded date

Notes on Date Search and Date Scan mode

- If a day's recording is not longer than 2 minutes, the camcorder may not accurately find its boundaries.
- Date Search and Date Scan do not function on a tape recorded by a camcorder without the Data Code function. Your camcorder has the Data Code function.
- When searching the boundaries of date on the tape, the forwarded or reversed picture appears in the viewfinder. Visual noise also appears during this searching. This is not a malfunction.

Returning to a pre-registered position

Using the Remote Commander, you can easily go back to the desired point on a tape after playback. Use the tape counter. If the RC time code appears in the viewfinder, set COUNTER to NORMAL in the menu system to display the tape counter.

- (1) During playback, press COUNTER RESET at the point you later want to locate. The counter shows "0:00:00" in the viewfinder.
- (2) Press \square when you want to stop playback.
- (3) Press ZERO MEM on the Remote Commander. The ZERO MEM indicator flashes in the viewfinder.
- (4) Press \lll to rewind or press \ggg to fast-forward the tape to the counter's zero point. The tape stops automatically when the counter reaches approximately zero.

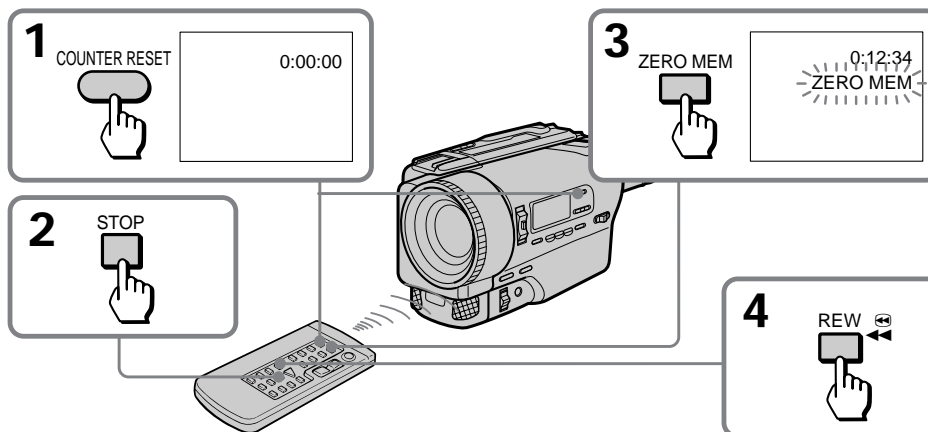

Notes on the tape counter

- Something must be recorded on the tape in order for the tape counter to function. Tape counter does not work on a blank tape.
- There may be a discrepancy of several seconds from the actual time.

Notes on ZERO MEM

- When you press ZERO MEM, the counter's zero point is memorized. Press ZERO MEM again before rewinding to cancel the memory.
- This function is cancelled automatically once the tape is rewound or advanced to the point you pre-registered.
- ZERO MEM does not function during recording or playing back.

Locating the marking position

You can locate the beginning of a desired program easily by marking an index signal during recording or playback and searching for it later.

Marking an index signal

You can mark an index signal during recording or playback.

When marking at the beginning of recording or playback

Press INDEX MARK on the Remote Commander in recording standby or playback pause mode. The INDEX MARK indicator appears in the viewfinder with the MARK indicator flashing. When recording or playback starts, the MARK indicator stops flashing. This shows that the index signal is being marked. Then the INDEX MARK indicator will disappear.

When marking during recording or playback

Press INDEX MARK on the Remote Commander at the point you want to locate later.

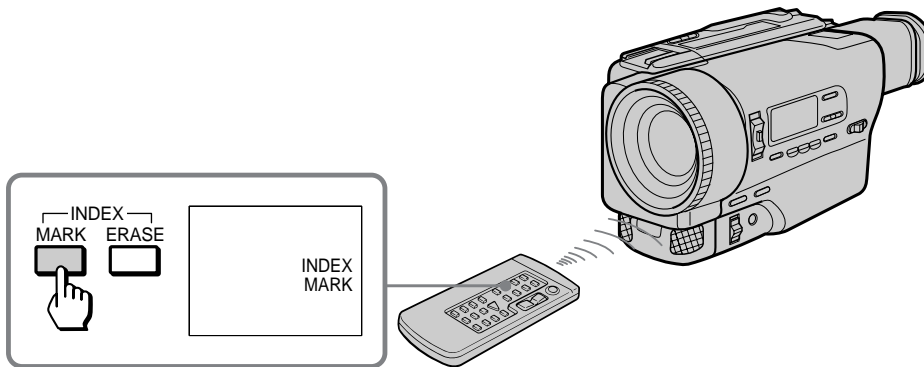

Notes on marking

- Make sure you mark index signals at more than two-minute intervals. Otherwise, you may not be able to search for them correctly.
- If you stop recording while the index signal is being marked (the INDEX MARK indicator lights in the viewfinder), the search may not be completed correctly.
- If you mark an index signal on the tape with the Data Code recorded, the Data Code will be erased at the point on which the index signal is marked. When playing back this tape, the camcorder keeps displaying the Data Code immediately before the erased one.
- A black band appears when you mark index signal during playback, and the sound is not recorded. This does not affect the picture and the sound that are already recorded.
- You cannot mark an index signal on a tape with the red mark on the cassette exposed, or on a tape recorded in LP mode.
- An index signal is marked automatically when you start recording with the POWER switch to VTR. When you start recording from recording pause mode, however, an index signal is not marked.

Locating the marking position

Scanning the beginning of each marking position – index scan

Use the Remote Commander. To view the picture on a TV, press DISPLAY.

- (1) Press INDEX on the Remote Commander during normal playback.
- (2) Press ◀◀ or ▶▶. The tape rewinds or advances rapidly and plays back for approximately 10 seconds from the point on which the index signal was marked. If you want to continue playback, press ▷. When you do not press any button, the tape is automatically scanned to the next program.

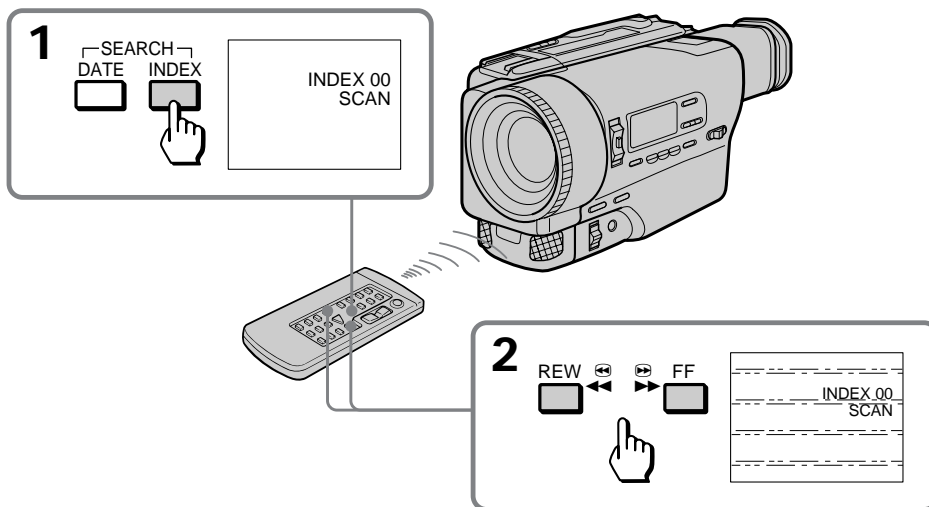

To cancel index scan mode

Press ▷. Normal playback resumes.

Locating the desired marking position - index search

- (1) Press INDEX on the Remote Commander during stop or playback mode.
- (2) Press INDEX repeatedly until the index number of the desired program is displayed in the viewfinder.
- (3) Press ◀◀ or ▶▶. Playback starts from the beginning of the desired program.

[a] the current position

[b] the INDEX number

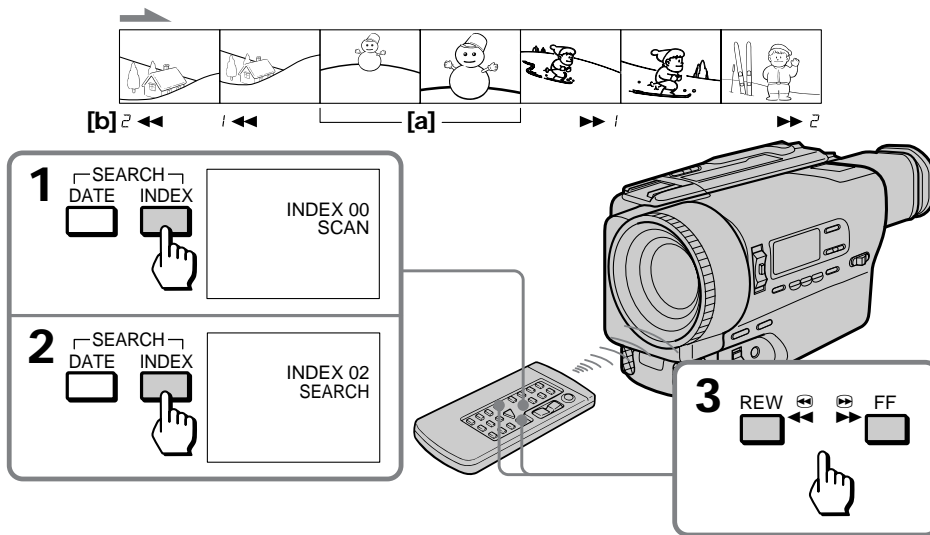

To stop index search mode

Press ▷. Normal playback resumes.

Note on the index number

The index number (1, 2, etc.) indicates the distance from the point you are now viewing [a], regardless of the direction.

Locating the marking position

Erasing an index signal

- (1) Locate the index signal to be erased using the index scan or index search function.
- (2) Press INDEX ERASE on the Remote Commander within 2 to 10 seconds while the desired program plays back. After the index signal is erased, the camcorder returns to index scan or index search mode, whichever was used in step 1.

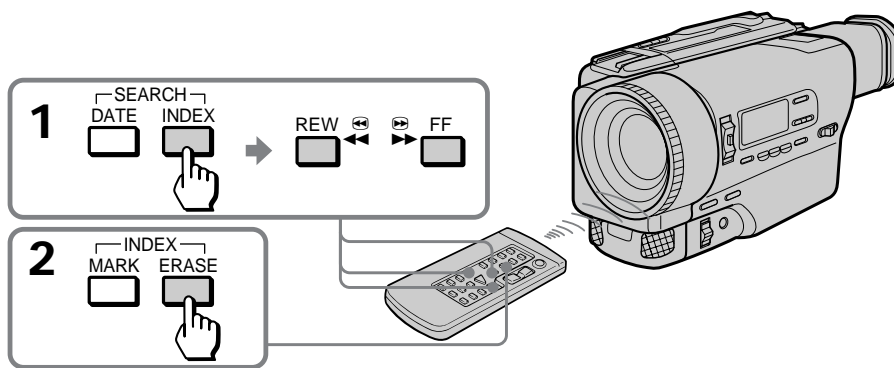

Notes on erasing

- Press INDEX ERASE more than 2 seconds after the playback of the desired program begins.
- You cannot erase the index signal on a tape with the red mark on the cassette exposed.
- While the index signal is being erased, the sound cannot be heard and a black band appears at the bottom of the picture. This will not affect the recorded sound or picture.
- The camcorder can detect index signals marked with VCRs, but cannot erase them. VCRs with an index function can detect index signals marked with this camcorder but cannot erase them.
- An index signal may be erased when making PCM after recording on another VCR in the portion where the index signal is marked.

Note on and Data Code

When an index signal is erased, Data Code on the same portion of the tape is also erased.

Writing the RC Time code on a recorded tape

You can write the RC time code on a recorded tape. Use the Remote Commander.

- (1) While pressing the small green button on the POWER switch, set it to VTR.
- (2) Rewind the tape to the beginning and set the camcorder to playback pause mode.
- (3) Press TIME CODE WRITE on the Remote Commander. The TIME CODE WRITE indicator appears in the viewfinder with the WRITE indicator flashing.
- (4) Press \blacktriangleright or || to start playback. The WRITE indicator stops flashing and the RC time code writing starts from 0:00:00:00.

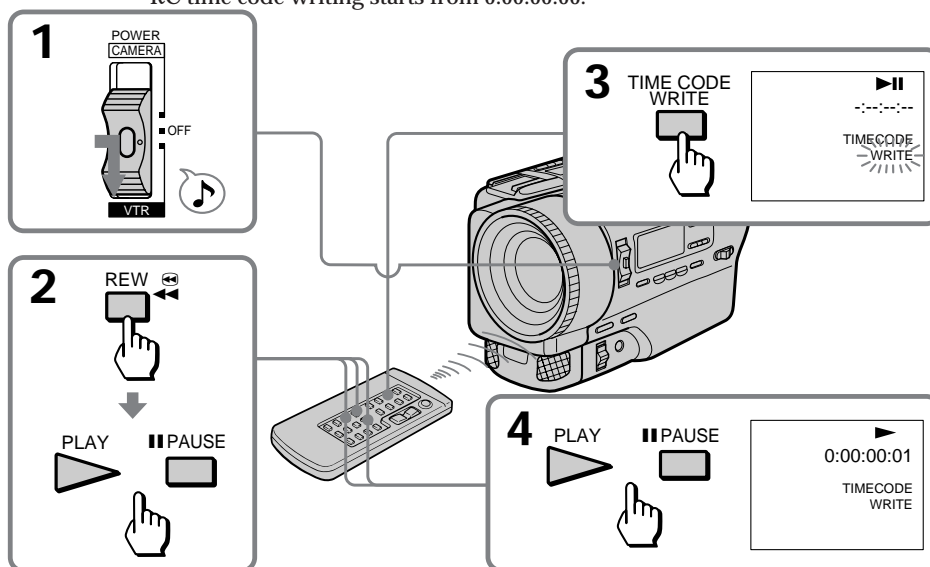

To stop writing the RC time code

Press \square (or any tape transport button).

To write the RC time code from the end of the RC time code recorded portion

Rewind the tape to the portion on which the RC time code has been written and set the camcorder to playback pause mode. Then follow steps 3 and 4 above. The RC time code is written continuously.

Notes on writing the RC time code

- The RC time code writing stops when:
 - you press TIME CODE WRITE again before starting playback.
 - you press INDEX before starting playback.
 - you change from playback mode to another mode.
- When you are writing the RC time code from the middle of a tape without the time code written, writing starts several frames before the current picture.
- If you write the RC time code on a recorded tape, the Data Code is erased.
- You cannot mark the RC time code on the tape that is recorded in LP mode. Though you can mark the RC time code on a tape recorded both in LP mode and SP mode, the RC time code written in LP mode, however, may not be read correctly.
- While the RC time code is being erased, the sound cannot be heard and a black band appears at the bottom of the picture. This will not affect the recorded sound or picture.

Writing the RC Time code on a recorded tape

Note on ---:---:--- indicator

The ---:---:--- indicator appears during playback if:

- nothing is recorded.
- the RC time code is unreadable because of the damage of the tape or because of the noise.
- you recorded using another VCR without RC time code function.
- you erase the index signal or make PCM after recording on another VCR in the portion on which the RC time code is written.

In this case, we recommend you to rewrite the RC time code.

Editing onto another tape

You can create your own video program by editing with any other **8 mm**, **Hi8** Hi8, **VHS** VHS, **S-VHS** S-VHS, **VHS-C** VHSC, **S-VHS-C** S-VHSC, **β** Betamax or **ED Beta** ED Betamax VCR that has video/audio inputs.

Before editing

Connect the camcorder to the VCR as described in “Connections for playback” on page 16.

Set the input selector on the VCR to LINE, if available.

- (1) While pressing the small green button on the POWER switch, set it to VTR.
- (2) Set EDIT to ON in the menu system.

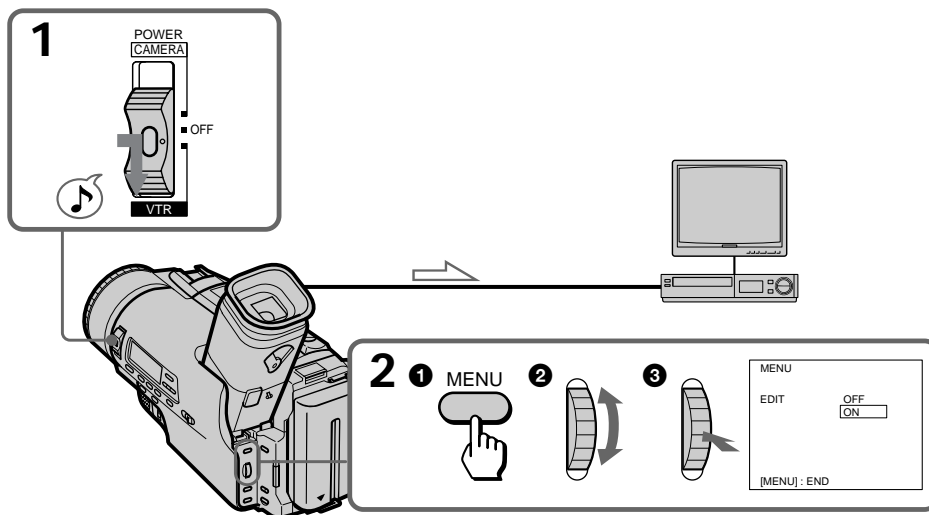



Starting editing

- (1) Insert a blank tape (or a tape you want to record over) into the VCR, and insert your recorded tape into the camcorder.
- (2) Play back the recorded tape on the camcorder until you locate the point where you want to start editing, then press **II** to set the camcorder in playback pause mode.
- (3) On the VCR, locate the recording start point and set the VCR in recording pause mode.
- (4) Press **II** on the camcorder and VCR simultaneously to start editing.

To edit more scenes

Repeat steps 2 to 4.

To stop editing

Press **□** on both the camcorder and the VCR.

Note on the DISPLAY function

If you have displayed the viewfinder screen indicators on the TV, erase the indicators by pressing DISPLAY on the Remote Commander so that they will not be superimposed on the edited tape.

Recording from a VCR or TV

You can record a tape from another VCR or TV program from a TV that has audio/video outputs. Connect the camcorder to the VCR or TV.

(1) While pressing the small green button on the POWER switch, set it to VTR.

(2) Press ● REC and the button on far right together at the point where you want to start recording.

In recording and recording pause mode, S VIDEO and VIDEO/AUDIO jacks automatically work as input jacks.

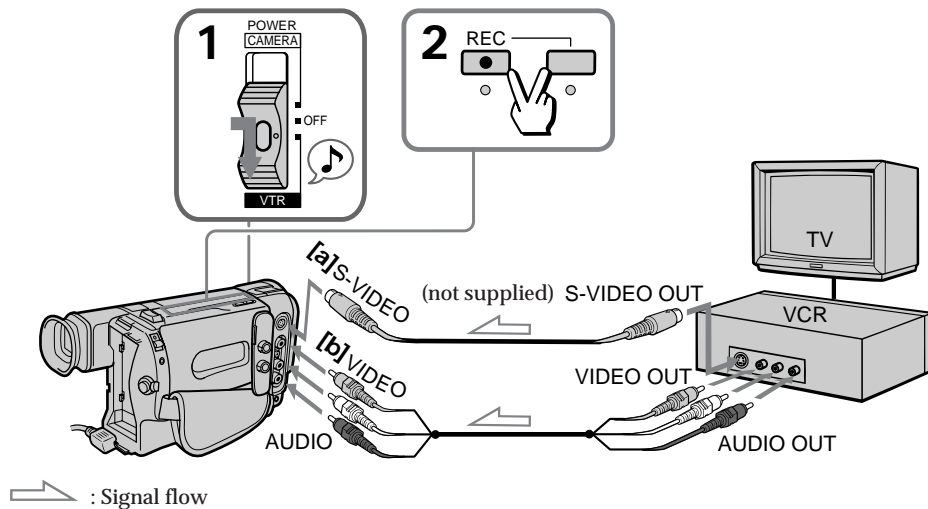

If your VCR or TV is a monaural type, connect only the white plug for audio on both the camcorder and the VCR or TV.

If you are going to connect the camcorder using the S video cable (not supplied) [a], you do not need to connect the yellow (video) plug of the A/V connecting cable [b].

Do not connect the S video cable to the camcorder if your VCR or TV doesn't have any S video jack.

To check the picture from a VCR or TV before recording

Press ■ after pressing ● REC. You can check the picture in the viewfinder.

To stop recording

Press □.

Replacing recording on a tape (insert editing)

You can insert a new scene from a VCR onto your originally recorded tape by specifying starting and ending points.

Connections are the same as in "Recording from a VCR or TV" on the previous page.

- (1) While pressing the small green button on the POWER switch, set it to VTR.
- (2) On the VCR, locate the start point to be inserted and set it to playback pause mode.
- (3) On the camcorder, locate the point where the insert should end by pressing ◀◀ or ▶▶, then press ⏸ to set it to playback pause mode.
- (4) Press COUNTER RESET to set the counter to zero.
- (5) On the camcorder, locate the point where the insert should begin by pressing ◀◀, then press ● REC and ⏸ to set it to recording pause mode.
- (6) Press ZERO MEM on the Remote Commander. The ZERO MEM indicator flashes and the end point of the insert is stored in memory.
- (7) Press ⏸ on the camcorder and the VCR simultaneously to start insert editing. The insert editing stops automatically near the counter's zero point.

To change the end point

Press ZERO MEM on the Remote Commander so that the ZERO MEM indicator disappears and begin from step 3.

Note on the inserted picture

The picture may be distorted at the end of the inserted portion when it is played back.

Additional Information

Changing the lithium battery in the camcorder

Your camcorder is supplied with a lithium battery installed. When the battery becomes weak or dead, the  indicator flashes in the viewfinder for about 5 seconds when you set the POWER switch to CAMERA. In this case, replace the battery with a Sony CR2025 or Duracell DL-2025 lithium battery. Use of any other battery may present a risk of fire or explosion.

The lithium battery for the camcorder lasts for about 1 year under normal operation. (The lithium battery that comes installed at the factory may not last 1 year.)

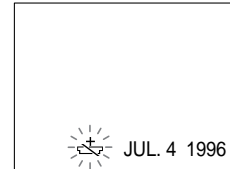

Note on lithium battery

The lithium battery has positive (+) side and negative (-) side as illustrated. Be sure to insert the lithium battery with the positive side facing out.



WARNING

The battery may explode if mistreated. Do not recharge, disassemble, or dispose of in fire.

Caution

Keep the lithium battery out of the reach of children. Should the battery be swallowed, consult a doctor immediately.

Changing the lithium battery

When replacing the lithium battery, keep the battery pack or other power source attached. Otherwise, you will need to reset the date, time and other items in the menu system retained by the lithium battery.

- (1) Open the lid of the lithium battery compartment.
- (2) Push the battery down once and pull it out from the holder.
- (3) Install the lithium battery with the positive (+) side facing out. Close the lid.

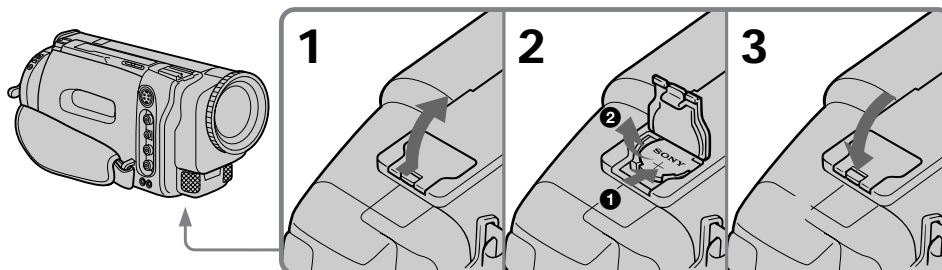

Resetting the date and time

You can set the date and time in the menu system.

- (1) Press MENU to display the menu in the viewfinder.
- (2) Turn the control dial to highlight CLOCK SET, and press the control dial to select it.
- (3) Turn the control dial to adjust the year, and then press the control dial.
- (4) Set the month, day, hour, and minutes by turning the control dial and then pressing the control dial.
- (5) Press MENU to erase the menu display.

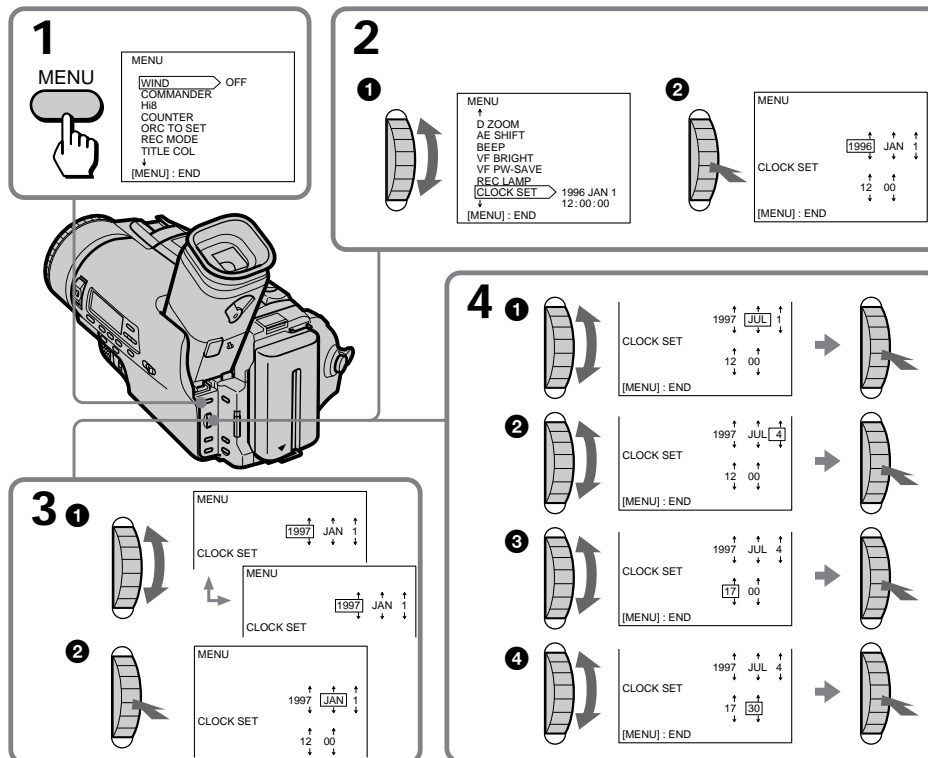

Additional Information

To correct the date and time setting

Repeat the above procedure.

To check the preset date and time

Press DATE to display the date indicator in the viewfinder.

Press TIME to display the time indicator.

When you press the same button again, the indicator goes off.

The year indicator changes as follows: 1996 ↔ 1997 ← … → 2029

Note on the time indicator

The internal clock of this camcorder operates on a 12-hour cycle.

- 12:00 AM stands for midnight.
- 12:00 PM stands for noon.

77

Usable cassettes and playback modes

Selecting cassette types

This Hi8 system is an extension of the standard 8 mm system, and was developed for higher-quality pictures.

You can use Hi8 video and standard 8 mm cassettes. When you want to record in the Hi8 system (in SP mode only), use only Hi8 video cassettes. You cannot record on standard 8 mm cassettes in the Hi8 system.

If you are going to play back the tape using a standard 8 mm video recorder/player, you should record the tape on a standard 8 mm system.

If you want to use a Hi8 cassette with the standard 8 mm video recorder system, set Hi8 to OFF in the menu system before recording.

To play back in	Hi8	Standard 8	
Record using cassette type	Hi8	Hi8	8
Set Hi8 setting to	AUTO	OFF	AUTO (or OFF)

When you play back

The playback mode (SP/LP or Hi8/standard 8 mm) is selected automatically according to the format in which the tape has been recorded. The quality of the recorded picture in LP mode, however, will not be as good as that in SP mode.

Note on AFM HiFi stereo

When you play back a tape, the sound will be in monaural if:

- You record the tape using this camcorder, then play it back on an AFM HiFi monaural video recorder/player.
- You record the tape on an AFM HiFi monaural video recorder, then play it back on this camcorder.

Recording mode

When you play back a tape, the SP/LP indicator in the viewfinder shows the recording mode LP/SP.

Foreign 8 mm video

Because the TV color systems differ from country to country, you may not be able to play back foreign pre-recorded tapes. Refer to the list of "Using your camcorder abroad" to check the TV color system of foreign countries.

Tips for using the battery pack

This section shows you how you can get the most out of your battery pack.

Preparing the battery pack

Always carry additional batteries

Have sufficient battery pack power to do 2 to 3 times as much recording as you have planned.

Battery life is shorter in a cold environment

Battery efficiency is decreased, and the battery will be used up more quickly, if you are recording in a cold environment.

To save battery power

Turn STANDBY down when not recording to save battery power.



A smooth transition between scenes can be made even if recording is stopped and started again. While you are positioning the subject, selecting an angle, or looking through the viewfinder lens, the lens moves automatically and the battery is used. The battery is also used when a tape is inserted or removed.

When to replace the battery pack

While you are using your camcorder, the remaining battery indicator in the viewfinder decreases gradually as battery power is used up.

When you use the NP-F530/F730 "InfoLIHTIUM" battery, the minute indicators appear with the remaining battery indicator while recording.



When the remaining battery indicator reaches the lowest point, the  indicator appears and starts flashing in the viewfinder. When you use the NP-F530/F730 battery, the  indicator may flash even if there are still 5 to 10 minutes of charge remaining.

When the  indicator in the viewfinder changes from slow flashing to rapid flashing while you are recording, set the POWER switch to OFF on the camcorder and replace the battery pack. Leave the tape in the camcorder to obtain a smooth transition between scenes after the battery pack has been replaced.

Notes on the rechargeable battery pack

Caution

Never leave the battery pack in temperatures above 140°F (60°C), such as in a car parked in the sun or under direct sunlight.

The battery pack heats up

During charging or recording, the battery pack heats up. This is caused by energy that has been generated and a chemical change that has occurred inside the battery pack. This is not cause for concern, and is normal.

Tips for using the battery pack

About InfoLITHIUM batteries

The “InfoLITHIUM” is a lithium ion battery pack which can exchange data with compatible video equipment about its battery consumption. Sony recommends that you use the “InfoLITHIUM” battery pack with video equipment having the  InfoLITHIUM mark.

When you use this battery pack with video equipment having the  InfoLITHIUM mark, the video equipment will indicate the remaining battery time in minutes*. However, if you use it with video equipment not having this mark, the remaining battery capacity will not be indicated in minutes.

* The indication may not be accurate depending on the condition and environment which the equipment is used under. If the indication is not accurate, use the battery pack completely and then charge it fully. The indication will become accurate. However, the indication may not become accurate if you use or leave the battery pack in a warm place for a long time, or after you have used the battery pack many times.

Battery pack care

- Remove the battery pack from the camcorder after using it, and keep it in a cool place. When the battery pack is installed to the camcorder, a small amount of current flows to the camcorder even if the POWER switch is set to OFF. This shortens battery life.
- The battery pack is always discharging even when it is not in use after charging. Therefore, you should charge the battery pack right before using the camcorder.

The switch on the battery pack

This switch is provided so that you can mark the charged battery pack. Set the switch to the “green mark” position when charging is completed. (When removed from the charging adaptor, the switch exposes the green mark. When removed from your camcorder, no mark is indicated.)

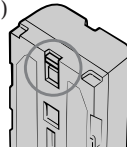

The life of the battery pack

If the battery indicator flashes rapidly just after turning on the camcorder with a fully charged battery pack, the battery pack should be replaced with a new fully charged one.

Charging temperature

You should charge batteries at temperatures from 50°F to 86°F (from 10°C to 30°C). Lower temperatures require a longer charging time.

Notes on charging

A brand-new battery pack

A brand-new battery pack is not charged. Before using the battery pack, charge it completely.

Recharge the battery pack whenever you like

You do not have to discharge it before recharging. If you charged the battery pack fully but you did not use it for a long time, it becomes discharged. Then recharge the battery pack before use.

Notes on the terminals

If the terminals (metal parts on the back) are not clean, the battery charge duration will be shortened.

When the terminals are not clean or when the battery pack has not been used for a long time, repeatedly install and remove the battery pack a few times. This improves the contact condition. Do not put any foreign objects such as dust or sand in the ⊕ and ⊖ terminals.

Be sure to observe the following

- Keep the battery pack away from fire.
- Keep the battery pack dry.
- Do not open nor try to disassemble the battery pack.
- Do not expose the battery pack to any mechanical shock.

Notes on the battery case

- Use only with alkaline batteries. You cannot use the battery case with manganese batteries or size AA (LR6) rechargeable NiCd batteries.
- Using with Sony alkaline batteries is preferable.
- Battery life is remarkably shorter in a cold environment (lower than 50°F/10°C).
- Keep the metal part clean. If it gets dirty, wipe it with a soft cloth.
- Do not disassemble or try to disassemble the battery case.
- Do not expose the battery case to any mechanical shock.
- During recording, the battery case heats up. This is not cause for concern.
- Prevent the electrode in the battery case from coming in contact with a metal object.
- If you will not use the battery case for a long time, detach the battery case from the camcorder and remove the batteries from the battery case.

Notes on alkaline batteries

To avoid possible damage from battery leakage or corrosion, observe the following.

- Be sure to insert the batteries in the correct direction.
- Alkaline batteries are not rechargeable.
- Do not use a combination of new and old batteries.
- Do not use different types of batteries.
- The batteries slowly discharge while not in use.
- Do not use a battery that is leaking.



If battery leakage occurred

- Wipe off the liquid in the battery case carefully before replacing the batteries.
- If you touch the liquid, wash it off with water.
- If the liquid get into your eyes, wash your eyes with a lot of water and then consult a doctor.

Maintenance information and precautions**Moisture condensation**

If the camcorder is brought directly from a cold place to a warm place, moisture may condense inside the camcorder, on the surface of the tape, or on the lens. In this condition, the tape may stick to the head drum and be damaged or the unit may not operate correctly. To prevent possible damage under these circumstances, the camcorder is furnished with moisture sensors. Please, take the following precautions.

Inside the camcorder

If there is moisture inside the camcorder, the beep sounds and the  indicator flashes. If this happens, none of the functions except cassette ejection will work. Open the cassette compartment, turn off the camcorder, and leave it about 1 hour. When  indicator flashes at the same time, the cassette is inserted in the camcorder. Eject the cassette, turn off the camcorder, and leave also the cassette about 1 hour.

Maintenance information and precautions

On the lens



If moisture condenses on the lens, no indicator appears, but the picture becomes dim. Turn off the power and do not use the camcorder for about 1 hour.

How to prevent moisture condensation

When bringing the camcorder from a cold place to a warm place, put the camcorder in a plastic bag and allow it to adapt to room conditions over a period of time.

- (1) Be sure to tightly seal the plastic bag containing the camcorder.
- (2) Remove the bag when the air temperature inside it has reached the temperature surrounding it (after about 1 hour).

Video head cleaning

To ensure normal recording and clear pictures, clean the video heads. When the  indicator and "  CLEANING CASSETTE" message appear one after another in the viewfinder or playback pictures are "noisy" or hardly visible, the video heads may be dirty.



[a] Slightly dirty

[b] Very dirty

If this happens, clean the video heads with the Sony V8-25CLH cleaning cassette (not supplied). After checking the picture, if it is still "noisy," repeat the cleaning. (Do not repeat cleaning more than 5 times in one session.)

Caution

Do not use a commercially available wet-type cleaning cassette. It may damage the video heads.

Note

If the V8-25CLH cleaning cassette is not available in your area, consult your nearest Sony dealer.

Precautions

Camcorder operation

- Operate the camcorder on 7.2 V (battery pack) or 8.4 V (AC power adaptor).
- For DC or AC operation, use the accessories recommended in this manual.
- Should any solid object or liquid get inside the casing, unplug the camcorder and have it checked by a Sony dealer before operating it any further.
- Avoid rough handling or mechanical shock. Be particularly careful of the lens.
- Keep the POWER switch set to OFF when not using the camcorder.
- Do not wrap up the camcorder and operate it since heat may build up internally.
- Keep the camcorder away from strong magnetic fields or mechanical vibration.

On handling tapes

Do not insert anything in the small holes on the rear of the cassette. These holes are used to sense the type of tape, thickness of tape and if the recording tab is in or out.

Camcorder care

- When the camcorder is not to be used for a long time, disconnect the power source and remove the tape. Periodically turn on the power, operate the camera and player sections and play back a tape for about 3 minutes.
- Clean the lens with a soft brush to remove dust. If there are fingerprints on it, remove them with a soft cloth.
- Clean the camcorder body with a dry soft cloth, or a soft cloth lightly moistened with a mild detergent solution. Do not use any type of solvent which may damage the finish.

AC power adaptor

Charging

- Use only a lithium ion type battery pack.
- Place the battery pack on a flat surface without vibration during charging.
- The battery pack will get hot during charging. This is normal.

Others

- Unplug the unit from the wall outlet when not in use for a long time. To disconnect the power cord, pull it out by the plug. Never pull the cord itself.
- Do not operate the unit with a damaged cord or if the unit has been dropped or damaged.
- Do not bend the AC power cord forcibly, or put a heavy object on it. This will damage the cord and may cause a fire or electrical shock.
- Be sure that nothing metallic comes into contact with the metal parts of the connecting plate. If this happens, a short may occur and the unit may be damaged.
- Always keep the metal contacts clean.
- Do not disassemble the unit.
- Do not apply mechanical shock or drop the unit.
- While the unit is in use, particularly during charging, keep it away from AM receivers and video equipment because it will disturb AM reception and video operation.
- The unit becomes warm while in use. This is normal.
- Do not place the unit in locations that are:
 - Extremely hot or cold
 - Dusty or dirty
 - Very humid
 - Vibrating

If any difficulty should arise, unplug the unit and contact your nearest Sony dealer.

Using your camcorder abroad

Each country has its own electric and TV color systems. Before using your camcorder abroad, check the following points.

Power sources

You can use your camcorder in any country with the supplied AC power adaptor within 110 V to 240 V AC, 50/60 Hz.

Use a commercially available AC plug adaptor [a], if necessary, depending on the design of the wall outlet [b].

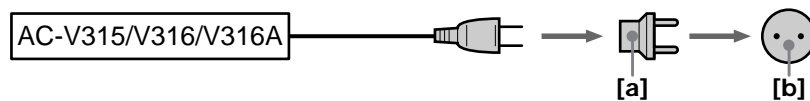

Difference in color systems

This camcorder is an NTSC system-based camcorder. If you want to view the playback picture on a TV, it must be an NTSC system-based TV.

Check the following list.

NTSC system countries

Bahama Islands, Bolivia, Canada, Central America, Chile, Colombia, Ecuador, Jamaica, Japan, Korea, Mexico, Peru, Surinam, Taiwan, the Philippines, the U.S.A., Venezuela, etc.

PAL system countries

Australia, Austria, Belgium, China, Denmark, Finland, Germany, Great Britain, Holland, Hong Kong, Italy, Kuwait, Malaysia, New Zealand, Norway, Portugal, Singapore, Spain, Sweden, Switzerland, Thailand, etc.

PAL-M system country

Brazil

PAL-N system countries

Argentina, Paraguay, Uruguay

SECAM system countries

Bulgaria, Czech Republic, France, Guyana, Hungary, Iran, Iraq, Monaco, Poland, Russia, Slovak Republic, Ukraine, etc.

Trouble check

If you run into any problem using the camcorder, use the following table to troubleshoot the problem. Should the difficulty persist, disconnect the power source and contact your Sony dealer or local authorized Sony service facility.

Camcorder







Power

Symptom	Cause and/or Corrective Action
The power is not on.	<ul style="list-style-type: none"> • The battery pack is not installed. → Install the battery pack. (p.8) • The battery is dead. → Use a charged battery pack. (p.6) • The AC power adaptor is not connected to a wall outlet. → Connect the AC power adaptor to a wall outlet. (p.22) • You use other types of battery except NP-F530/F730.
The power goes off.	<ul style="list-style-type: none"> • While being operated in CAMERA mode, the camcorder has been in Standby mode for more than 5 minutes. → Turn STANDBY down once and then up again. (p.11) • The battery is dead. → Use a charged battery pack. (p.6) • If the VF PW-SAVE is set to ON in the menu system, the picture disappears automatically when you turn your face away from the viewfinder. → Bring your face close to the viewfinder within 1/2 inch (1 cm). Or set VF PW-SAVE to OFF in the menu system. (p.26)
The battery pack is quickly discharged.	<ul style="list-style-type: none"> • The ambient temperature is too low. • The battery pack has not been charged fully. → Charge the battery pack again. (p.6) • The battery pack is completely dead, and cannot be recharged. → Use another battery pack. (p.8) • You use other types of battery except NP-F530/F730.
The beep sounds when the battery is attached.	<ul style="list-style-type: none"> • The battery pack is discharged during a long period of storage. → Charge the battery pack again. (p.6)
START/STOP does not operate.	<ul style="list-style-type: none"> • The tape is stuck to the drum. → Eject the tape. (p.9) • The tape has run out. → Rewind the tape or use a new one. (p.19) • The POWER switch is set to VTR. → Set it to CAMERA. (p.10) • The tab on the cassette is out (red). → Use a new tape or slide the tab. (p.9)

(to be continued)

Trouble check

Operation

Symptom	Cause and/or Corrective Action
Recording stops in a few seconds.	<ul style="list-style-type: none"> The START/STOP MODE switch is set to 5 SEC or . → Set it to . (p.41)
The cassette cannot be removed from the holder.	<ul style="list-style-type: none"> The battery is dead. → Use a charged battery pack or the AC power adaptor. (p.6, 22)
 and  indicators flash and no function except for cassette ejection works.	<ul style="list-style-type: none"> Moisture condensation has occurred. → Remove the cassette and leave the camcorder for at least 1 hour. (p.9)
The counter, date, or time indicator is flashing.	<ul style="list-style-type: none"> You pressed DATE and TIME together for more than 2 seconds. → The camcorder is not malfunctioning. You may start recording. Flashing will stop soon. The lithium battery is weak or dead. → Replace the lithium battery with a new one. (p.76)
The tape does not move when a tape transport button is pressed.	<ul style="list-style-type: none"> The POWER switch is set to CAMERA or OFF. → Set it to VTR. The tape has run out. → Rewind the tape or use a new one. (p.19)
The date or time indicator disappears.	<ul style="list-style-type: none"> Reset the date and time. (p.77)
The Steady Shot function does not activate.	<ul style="list-style-type: none"> STEADY SHOT is set to OFF. → Set STEADY SHOT to ON. (p.46)
The autofocusing function does not work.	<ul style="list-style-type: none"> FOCUS is set to MANUAL. → Set it to AUTO. (p.50) Shooting conditions are not suitable for autofocus. → Set FOCUS to MANUAL to focus manually. (p.49)
The fader function does not work.	<ul style="list-style-type: none"> START/STOP MODE is set to 5 SEC or . → Set it to . (p.41) A title is displayed. → Stop superimposing the title. (p.43)
No sound or only a low sound is heard when playing back a tape.	<ul style="list-style-type: none"> The stereo tape is played back with HiFi SOUND set to 1 or 2 in the menu system. → Set to STEREO in the menu system. (p.27)
Excessive high-pitched sound is heard.	<ul style="list-style-type: none"> The picture has been recorded with WIND set to ON in the menu system. → When there is no wind, set it to OFF. (p.26)



Picture

Symptom	Cause and/or Corrective Action
The image on the viewfinder screen is not clear.	<ul style="list-style-type: none"> The viewfinder lens is not adjusted. → Adjust the viewfinder lens. (p.11)
A vertical band appears when a subject such as lights or a candle flame is shot against a dark background.	<ul style="list-style-type: none"> The contrast between the subject and background is too high. The camcorder is not malfunctioning. → Change locations.
A vertical band appears when shooting a very bright subject.	<ul style="list-style-type: none"> The camcorder is not malfunctioning.
The menu is not displayed on the TV.	<ul style="list-style-type: none"> DISPLAY on the Remote Commander has not been pressed. → Press DISPLAY on the Remote Commander. (p.19)
The playback picture is not clear.	<ul style="list-style-type: none"> EDIT is set to ON in the menu system. → Set it to OFF. (p.27)
The picture is "noisy".	<ul style="list-style-type: none"> The video heads may be dirty. → Clean the heads using the Sony V8-25CLH cleaning cassette (not supplied). (p.82)
The picture is too bright or too dark.	<ul style="list-style-type: none"> AE SHIFT is set in the menu system. → Set it to the center position. (p.61) VF BRIGHT is set in the menu system. → Set it to the center position. (p.26)
The colors of the playback picture is strange.	<ul style="list-style-type: none"> AUTO LOCK/HOLD is set to the center position and a white balance indicator appears in the viewfinder. → Set it to AUTO LOCK. (p.63) Shooting conditions were not suitable for automatic white balance operation. → Adjust the white balance manually. (p.63)
White dots appear in the viewfinder.	<ul style="list-style-type: none"> Slow shutter function works. → The camcorder is not malfunctioning.
A vertical band appears when shooting a very bright subject.	<ul style="list-style-type: none"> The camcorder is not malfunctioning.
An unknown picture is displayed.	<ul style="list-style-type: none"> The camcorder is operating in Demo mode. → Exit Demo mode. (p.93)

Others

Symptom	Cause and/or Corrective Action
The supplied Remote Commander does not work.	<ul style="list-style-type: none"> COMMANDER is set to OFF in the menu system. → Set it to ON. (p.25) Something is blocking the infrared rays. → Remove the obstacle. The batteries are not inserted with the correct polarity. → Insert the batteries with the correct polarity. (p.94) The batteries are dead. → Insert new ones. (p.94)
The CHARGE lamp flashes after you charge the battery pack installed in the camcorder. (CCD-TR3300 for Canadian model only)	<ul style="list-style-type: none"> The camcorder is not malfunctioning.

(to be continued)

Trouble check

AC power adaptor

Symptom	Corrective Actions
The VTR/CAMERA or CHARGE lamp does not light.	<ul style="list-style-type: none"> • Disconnect the power cord. After about 1 minute, reconnect the power cord.
The CHARGE lamp flashes.	<ul style="list-style-type: none"> • See the following chart.

When the CHARGE lamp flashes

Check through the following chart.

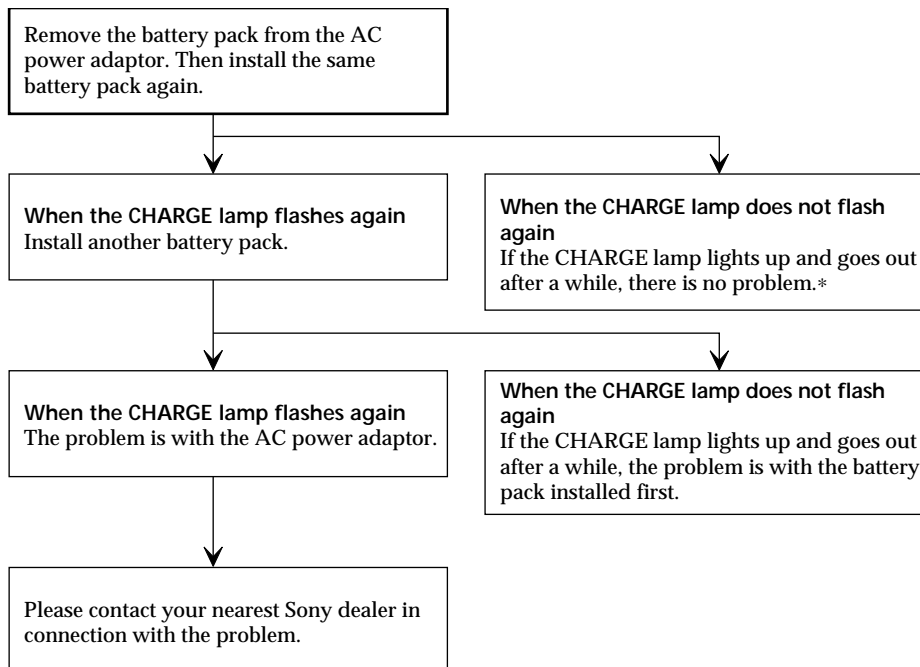

* If you use a battery pack which you have just bought or which has been left unused for a long time, the CHARGE lamp may flash at the first charging. This does not indicate a problem. Repeat again to charge with the same battery pack.

Specifications

Video camera recorder

System

Video recording system
Two rotary heads, Helical scanning FM system

Audio recording system
Rotary heads, FM system

Video signal
NTSC color, EIA standards

Usable cassette
8mm video format cassette (Hi8 or standard 8 mm)



Recording/Playback time
SP mode: 2 hours (E6/P6-120)
LP mode: 4 hours (E6/P6-120)
When you use a Hi8 video cassette, you cannot record in LP mode.

Fastforward/rewind time
Approx. 4 min. (E6/P6-120)

Image device
CCD (Charge Coupled Device)

Viewfinder
Electronic viewfinder (color)

Lens
Combined power zoom lens
Filter diameter 52 mm
42 x (Digital), 21 x (Optical)
Focal distance
 $5/32 - 3 1/4$ inches (3.9 - 81.9 mm)
 $1 1/2 - 30 5/8$ inches (37 - 777 mm)
when converted to a 35 mm still camera

Color temperature
Auto,
One push white balance ,
Indoor  3,200 K,
Outdoor  5,800 K

Minimum illumination
3 lux at F1.6
0.1 lux at F1.6 when using the Slow shutter function (CCD-TR3300 only)

Illumination range
3 lux to 100,000 lux

Recommended illumination
More than 100 lux

Input and output connectors

S video input/output
4-pin mini DIN
Luminance signal: 1 Vp-p, 75 ohms, unbalanced
Chrominance signal: 0.286 Vp-p, 75 ohms, unbalanced

Video input/output
Phono jack, 1 Vp-p, 75 ohms, unbalanced

Audio input/output
Phono jacks (2: stereo L and R)
Input: 327 mV, input impedance more than 47 kilohms
Output: 327 mV, (at output impedance 47 kilohms)
impedance less than 2.2 kilohms

RFU DC OUT
Special minijack, DC 5 V

Headphone jack
Stereo minijack

LANC control jack
Stereo mini-minijack (ø 2.5 mm)

MIC jack
Minijack, 0.388 mV low impedance with 2.5 to 3.0 V DC, output impedance 6.8 kilohms (ø 3.5 mm)
Stereo type

General

Power requirements
7.2 V (battery pack)
8.4 V (AC power adaptor)

Average power consumption
CCD-TR3300:
4.6 W during camera recording
CCD-TR2300:
4.5 W during camera recording

Operating temperature
32°F to 104°F (0°C to 40°C)

Storage temperature
-4°F to +140°F (-20°C to +60°C)

Dimensions (Approx.)
 $4 3/8 \times 4 3/8 \times 8 7/8$ inches (110 x 110 x 215 mm) (w/h/d)

Mass (Approx.)
2 lb (930 g) excluding the battery pack, lithium battery, cassette, lens cap and shoulder strap
2 lb 6 oz (1.1 kg) including the battery pack NP-F530, lithium battery CR 2025, cassette E6/P6-120, lens cap and shoulder strap

Microphone
Stereo type

Supplied accessories
See page 5.

AC power adaptor

Power requirements
110 - 240 V AC, 50/60 Hz

Power consumption
25 W

Output voltage
DC OUT: 8.4 V, 1.9 A in operating mode
Battery charge terminal: 8.4 V, 1.4 A in charge mode

Application
Sony battery packs NP-F530, NP-F730 lithium ion type

Operating temperature
32°F to 104°F (0°C to 40°C)

Storage temperature
-4°F to +140°F (-20°C to +60°C)

Dimensions (Approx.)
 $3 1/4 \times 1 15/16 \times 6 1/2$ inches (81 x 45 x 163 mm) (w/h/d) including projecting parts and controls

Mass (Approx.)
AC-V315:
1 lb 1 oz (480 g)
AC-V316/V316A:
1 lb 3 oz (560 g)

Design and specifications are subject to change without notice.

Edit Station (for CCD-TR3300 for Canadian model only)

Refer to the Operating Instructions of HSA-EC1 Edit Station.

Additional information

Identifying the parts

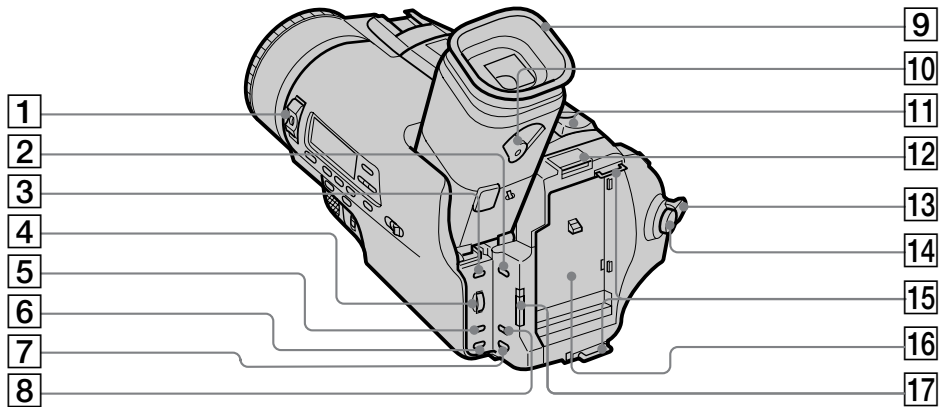

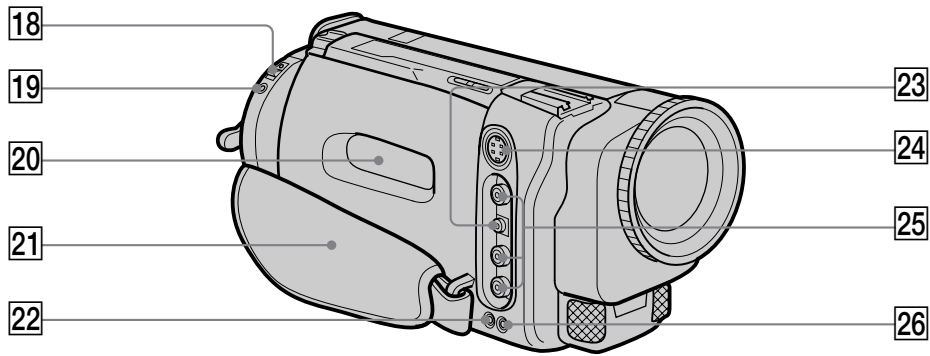

- | | |
|--------------------------------------------------|--------------------------------------------|
| 1 POWER switch (p.10) | 9 Eyecup (p.14) |
| 2 STEADY SHOT switch (p.46) | 10 Viewfinder lens adjustment lever (p.11) |
| 3 MENU button (p.25) | 11 Power zoom lever (p.12) |
| 4 Control dial (p.25) | 12 BATT (battery) PUSH button (p.8) |
| 5 PICTURE EFFECT button (p.34) | 13 STANDBY switch (p.10, 11) |
| 6 DIGITAL EFFECT button (CCD-TR3300 only) (p.35) | 14 START/STOP button (p.10, 11) |
| 7 TITLE button (p.43) | 15 Hooks for shoulder strap (p.96) |
| 8 16:9WIDE button (p.39) | 16 Battery mounting surface |
| | 17 START/STOP MODE switch (p.41) |



18 EJECT switch (p.9)

19 LANC  control jack

 stands for Local Application Control Bus System. The  control jack is used for controlling the tape transport of video equipment and peripherals connected to it. This jack has the same function as the jack indicated as CONTROL L or REMOTE.

20 Cassette compartment (p.9)

21 Grip strap (p.14)

22  (headphone) jack (p.19)

23 RFU DC OUT (RFU adaptor DC output) jack (p.16)

24 S VIDEO jack (p.16, 17)

25 VIDEO/AUDIO jacks (p.16, 17)

26 MIC jack (PLUG IN POWER)

Connect an external microphone (not supplied). This jack also accepts a "plug-in-power" microphone.

Additional information

Identifying the Parts

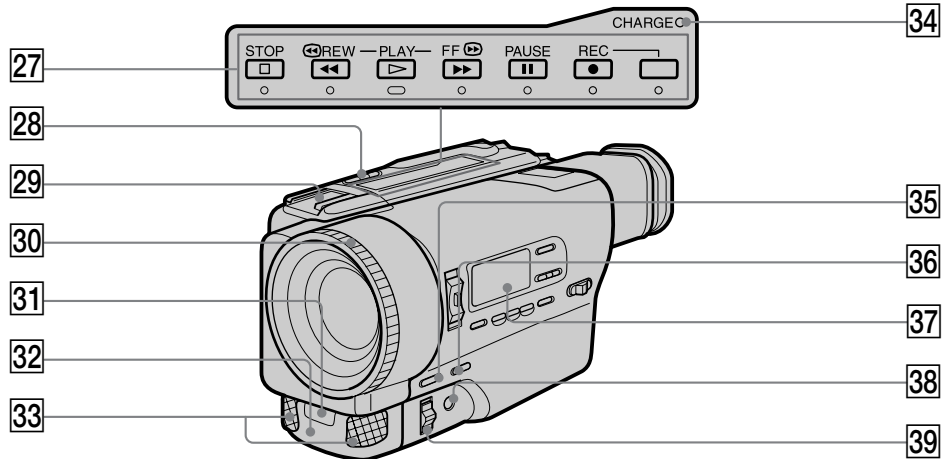

- | | |
|------------------------------------------------------------------------------------------------------------------------------------------------------------------------------------------------------------------------------------------------------------------|------------------------------------------------------------------------------------------------------------------|
| <p>27 Tape transport buttons (p.19, 20, 74, 75)</p> <ul style="list-style-type: none"> □ STOP (stop) ◀◀ REW (rewind) ▶ PLAY (playback) ▶▶ FF (fastforward) PAUSE (pause) ● REC (recording) | <p>34 CHARGE lamp (CCD-TR3300 for Canadian model only) (p.23)</p> |
| <p>28 EDITSEARCH button (p.15)</p> | <p>35 FADER/OVERLAP button (CCD-TR3300 only) (p.29, 31, 32)
FADER button (CCD-TR2300 only) (p.29)</p> |
| <p>29 Accessory shoe
Supplies power to optional accessories such as a video light.</p> | <p>36 BACKLIGHT button (p.60)</p> |
| <p>30 Focus ring (p.49)</p> | <p>37 Display window (p.97)</p> |
| <p>31 Remote sensor (p.95)
Aim the Remote Commander here for remote control.</p> | <p>38 PUSH AUTO button (p.50)</p> |
| <p>32 Camera recording/battery lamp (p.10)</p> | <p>39 FOCUS switch (p.49)</p> |
| <p>33 Microphone</p> | |

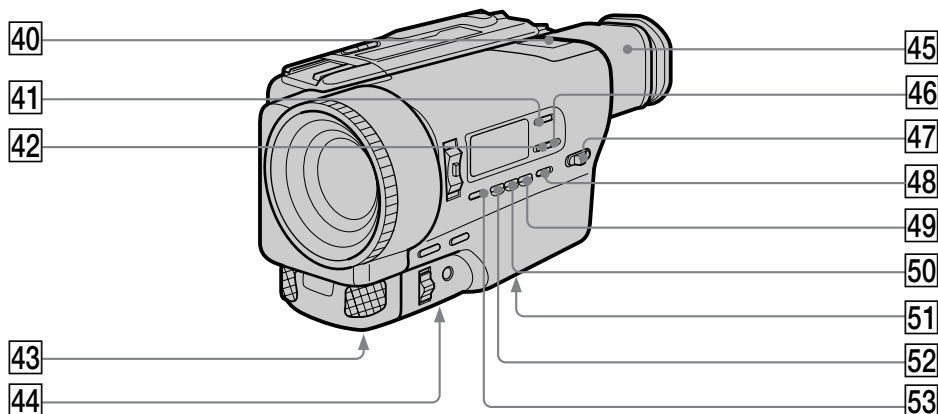

- | | | | |
|----|-------------------------------------|----|-------------------------------------------------------------------------------|
| 40 | Lighting aperture | 45 | Viewfinder (p.11) |
| 41 | COUNTER RESET button (p.11, 38, 66) | 46 | TIME button (p.21, 28) |
| 42 | DATE button (p.21, 28) | 47 | AUTO LOCK/HOLD switch (p.51) |
| 43 | Lithium battery compartment (p.76) | 48 | WHT BAL(white balance) button (p.63) |
| 44 | Tripod receptacle (p.14) | 49 | GAIN button (p.55) |
| | | 50 | SHUTTER SPEED button (p.55, 57) |
| | | 51 | Handycam station connection
(CCD-TR3300 for Canadian model only)
(p.18) |
| | | 52 | IRIS button (p.55) |
| | | 53 | PROGRAM AE button (p.51) |

Additional information

To Watch the demonstration

You can watch a brief demonstration of pictures with special effects.

If the demonstration appears when you turn on the camcorder for the first time, exit the demo mode to use your camcorder.

To enter Demo mode

- (1) Remove the cassette and set the POWER switch to VTR.
- (2) Turn STANDBY up.
- (3) While holding down \blacktriangleright , set the POWER switch to CAMERA. Demonstration starts.

If a cassette is inserted, the demo mode will stop. Note that once you enter demo mode, this mode is retained as long as lithium battery is in place. Therefore demonstration starts automatically 10 minutes later every time you set the POWER switch to CAMERA or 10 minutes after the cassette has been removed.

To exit Demo mode

- (1) Turn the POWER switch to VTR.
- (2) Turn STANDBY up.
- (3) While holding down \square , turn the POWER switch to CAMERA.

Identifying the parts

Remote Commander

The buttons that have the same name on the Remote Commander as on the camcorder function identically.

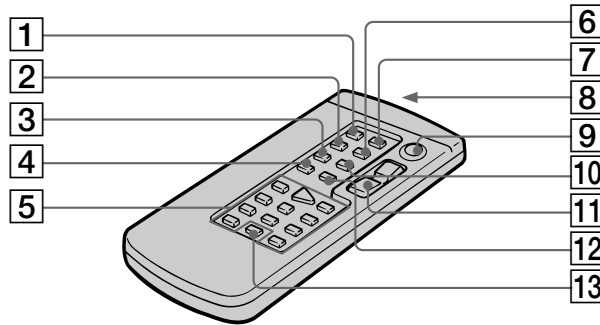

- | | |
|---------------------------------------|---------------------------------------|
| 1 COUNTER RESET button (p.11, 38, 66) | 9 START/STOP button (p.10, 11) |
| 2 TIME CODE WRITE button (p.71) | 10 INDEX ERASE (p.70) |
| 3 INDEX MARK (p.67) | 11 Power zoom button (p.12) |
| 4 DATE SEARCH button (p.65) | 12 INDEX SEARCH button (p.68, 69, 70) |
| 5 Tape transport buttons (p.19) | 13 DISPLAY button (p.19) |
| 6 DATA CODE button (p.21) | |
| 7 ZERO MEM button (p.38, 66) | |
| 8 Transmitter | |

Point toward the remote sensor to control the camcorder after turning on the camcorder.

To prepare the Remote Commander

To use the Remote Commander, you must insert two size AA (R6) batteries. Use the supplied size AA (R6) batteries.

- (1) Remove the battery cover from the Remote Commander.
- (2) Insert both of the size AA (R6) batteries with correct polarity.
- (3) Put the battery cover back onto the Remote Commander.

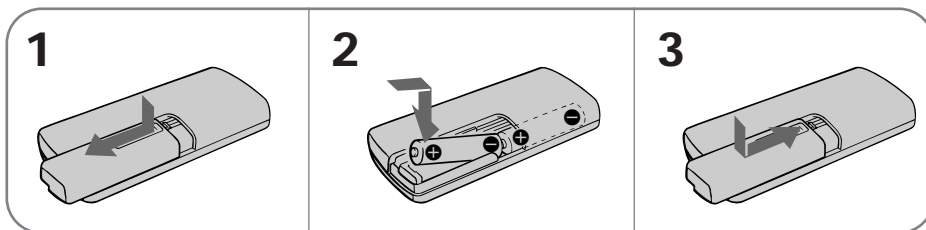

Note on battery life

The batteries for the Remote Commander last about 6 months under normal operation. When the batteries become weak or dead, the Remote Commander does not work.

To avoid damage from possible battery leakage

Remove the batteries when you will not use the Remote Commander for a long time.

To use the Remote Commander

Make sure that the COMMANDER is set to ON in the menu system on the camcorder. When using the Handycam Station, set COMMAND MODE to VTR 2 and aim the Remote Commander at the remote sensor on the Edit Station.

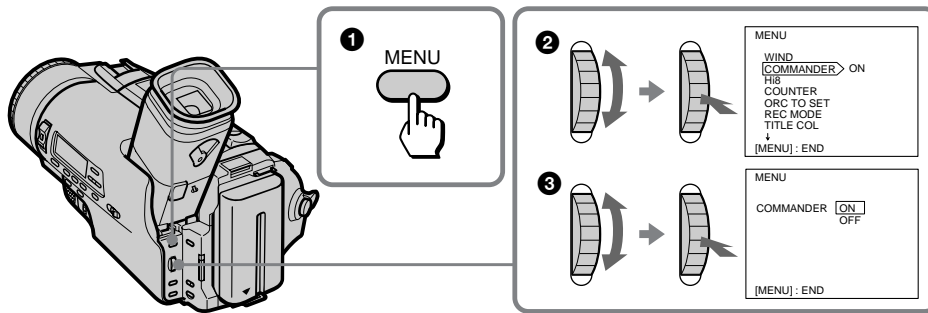

Additional information

Remote control direction

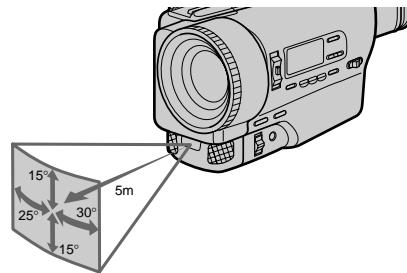

Notes on the remote commander

- Keep the remote sensor away from strong light sources such as direct sunlight or illumination. Otherwise, the remote control may not be effective.
- Be sure that there is no obstacle between the remote sensor on the camcorder and the Remote Commander.
- This camcorder works in commander mode VTR 2. The commander modes (1, 2 and 3) are used to distinguish this camcorder from other Sony VCRs to avoid remote control misoperation. If you use another Sony VCR in commander mode VTR 2, we recommend you change the commander mode or cover the remote sensor of the VCR with black paper.

Identifying the parts

Attaching the shoulder strap

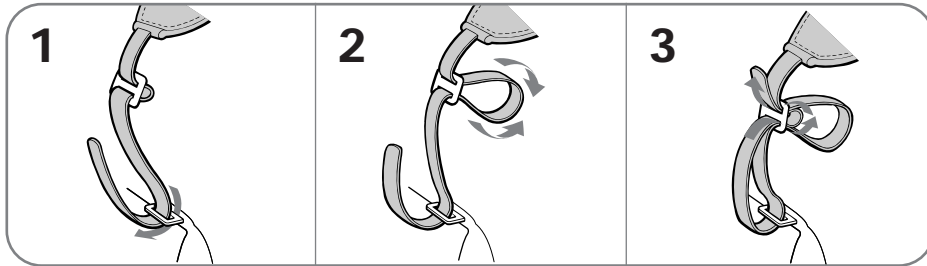

Attach the supplied shoulder strap to the hooks for the shoulder strap .

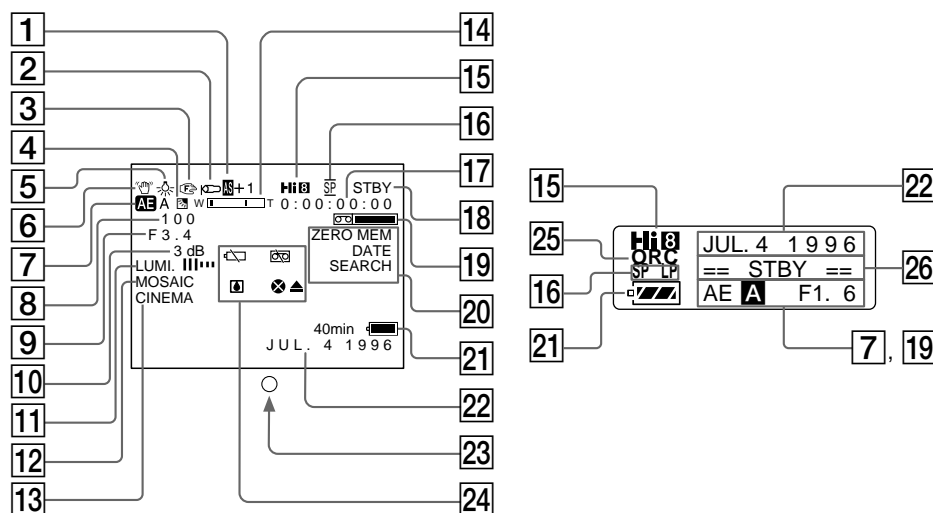

Operations indicators



Additional information

- | | |
|------------------------------------------------------------------------------------------------------------------------------------------------------------------------------------------------------------------------------------------------------------------------------------------------------------------------------------------------------------------------------------------------------------------------------------------------------------------------------------------------------------------------------------------------------------------------------------------------------------------------------------------------------------------------------------------------------------------------------------------------------------------------------------------------------------------------------------------------|-----------------------------------------------------------------------------------------------------------------------------------------------------------------------------------------------------------------------------------------------------------------------------------------------------------------------------------------------------------------------------------------------------------------------------------------------------------------------------------------------------------------------------------------------------------------------------------------------------------------------------------------------------------------------------------------------------------------------------------------------|
| <ul style="list-style-type: none"> 1 AE Shift indicator (p.61) 2 WIND indicator (p.26) 3 Manual focusing (p.49) 4 Backlight indicator (p.60) 5 White balance indicator (p.62) 6 Steady Shot indicator (p.46) 7 PROGRAM AE indicator (p.51) 8 Shutter speed indicator (p.52, 55, 57) 9 Iris indicator (p.51, 55) 10 Gain indicator (p.55) 11 FADER indicator (CCD-TR2300) (p.29)
Digital Effect and FADER/OVERLAP/
WIPE indicator (CCD-TR3300)
(p.29, 31, 32, 35, 36, 37) 12 Picture Effect indicator (p.34) 13 Wide mode indicator (p.39) 14 Zoom indicator (p.13) 15 Playing back or recording in Hi8 format
(p.78) 16 Recording/playing back mode indicator
(p.78) | <ul style="list-style-type: none"> 17 Tape counter/RC time code indicator
(p.25, 71) 18 Standby indicator (p.10) 19 Remaining tape indicator
 20 Date search/Date scan indicator/TIME
CODE WRITE indicator/ZERO MEM
indicator (p.65, 66, 71) 21 Remaining battery indicator (p.79)
 22 Date or Time indicator (p.28) 23 Recording lamp/Battery lamp (p.10) 24 Warning indicators (p.98) 25 ORC indicator (p.47) 26 Tape transport mode (p.19, 20) |
|------------------------------------------------------------------------------------------------------------------------------------------------------------------------------------------------------------------------------------------------------------------------------------------------------------------------------------------------------------------------------------------------------------------------------------------------------------------------------------------------------------------------------------------------------------------------------------------------------------------------------------------------------------------------------------------------------------------------------------------------------------------------------------------------------------------------------------------------|-----------------------------------------------------------------------------------------------------------------------------------------------------------------------------------------------------------------------------------------------------------------------------------------------------------------------------------------------------------------------------------------------------------------------------------------------------------------------------------------------------------------------------------------------------------------------------------------------------------------------------------------------------------------------------------------------------------------------------------------------|

Warning indicators

If indicators flash in the viewfinder or in the display window, check the following:
 ♪: you can hear the beep sound when the BEEP is set to ON.

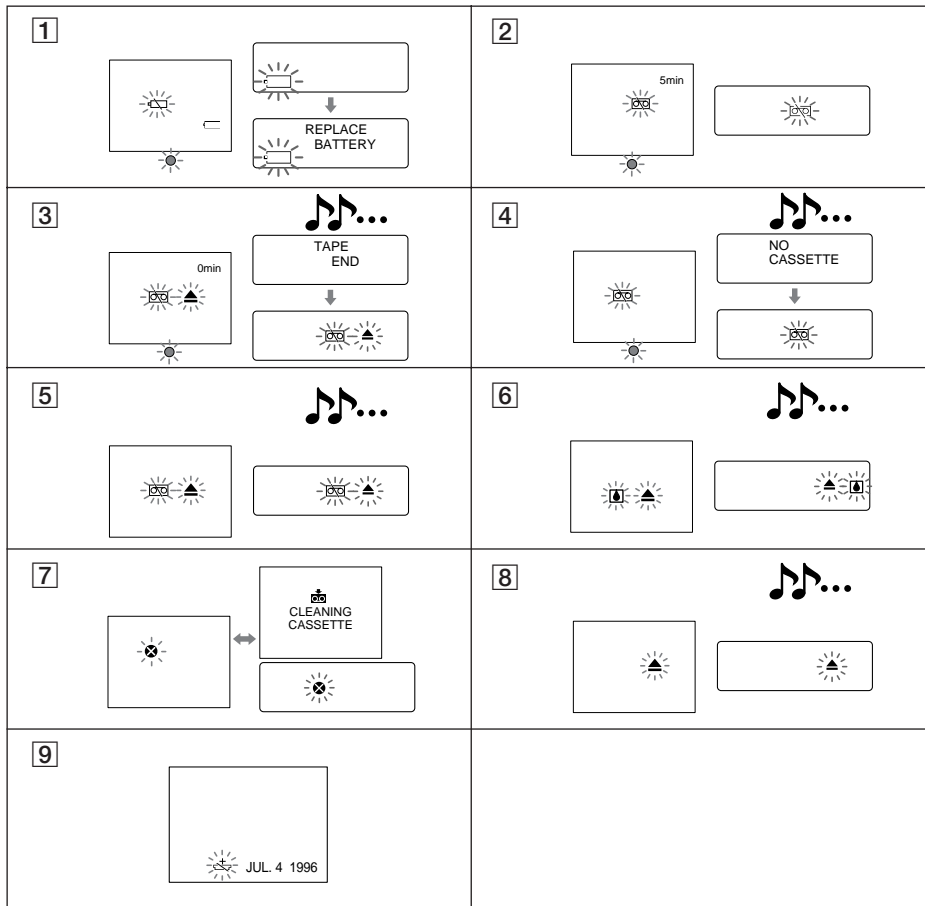

- | | |
|---------------------------------------------------------------------------------------------------------------------------------------------------------------------------------------------------------------------------------------------------------------------------------------------------------------------------------------------------------------------------------------------------------------------------------------------------------------------------------|-------------------------------------------------------------------------------------------------------------------------------------------------------------------------------------------------------------------------------------------------------------------------------------------------------------------------------------------------------------------|
| <p>1 The battery is weak or dead.
 Slow flashing: The battery is weak.
 Fast flashing: The battery is dead.</p> <p>2 The tape is near the end.
 The flashing is slow.</p> <p>3 The tape has run out.
 The flashing becomes rapid.</p> <p>4 No tape has been inserted.</p> <p>5 The tab on the tape is out (red).</p> <p>6 Moisture condensation has occurred.
 (p.81)</p> | <p>7 The video heads may be contaminated.
 (p.82)
 This indicator appears only on the viewfinder.</p> <p>8 Some other trouble has occurred.
 Disconnect the power source and contact your Sony dealer or local authorized facility.</p> <p>9 The lithium battery is weak or is not installed. (p.76)</p> |
|---------------------------------------------------------------------------------------------------------------------------------------------------------------------------------------------------------------------------------------------------------------------------------------------------------------------------------------------------------------------------------------------------------------------------------------------------------------------------------|-------------------------------------------------------------------------------------------------------------------------------------------------------------------------------------------------------------------------------------------------------------------------------------------------------------------------------------------------------------------|

Index

A, B

Adjusting viewfinder 11
AE shift 61
AFM HiFi Sound 78
Aperture 55
Aperture priority mode 51
Auto focus 50
Backlight 60
Beep 12, 25

C, D

Camera recording 10
Car battery 24
Charging battery 6
Cleaning video heads 82
Clock set 77
Connection 16 – 18
COUNTER RESET 38
Data code 21
DATE/TIME 28
Date scan 65 – 66
Date search 65 – 66
DEMO 93
Digital zoom 26
DISPLAY 19
DNR 27

E

EDIT 27, 72
Editing 72 – 73
EDITSEARCH 15, 38
Edit Station 17
Eject switch 9

F, G, H

Fade-in/Fade-out 29 – 30
FADER 29
Flash motion 36
GAIN 55
House current 22

I, J, K, L

Index 67 – 70
LANC 91
Lithium battery 76
LUMI 37

M, N

Manual adjustment 48
Manual focus 49 – 50
Menu system 25 – 27
MIC (microphone) jack 91

O, P

ORC 47
OVERLAP 31
PICTURE EFFECT 33 – 34
Playback on a TV 19
Playback pause 20
Power sources 22 – 24
Power zoom 12 – 13
PROGRAM AE 51 – 53
PUSH AUTO 50

Q, R

RC time code 71
Rec review 15
Remote control jack
(LANC) 91
Reverse 20

S

Shoulder strap 96
Skip scan 20
Shutter priority mode 52
Shutter speed 55
Standby mode 10 – 11
START STOP mode 41
STEADY SHOT 46

T, U, V

Tape counter 11, 97
TBC 27
Time code 25, 71
Title 42 – 45
Tripod mounting 14
Trouble check 85 – 88

W, X, Y, Z

WIDE mode 39 – 40
WIND 26
WIPE 32
Zoom 12 – 13

