

SONY[®]



Operation Guide
NWD-E023F / E025F

About the Manuals

The following manuals are supplied with the player. Additionally, after connecting the player, you can refer to the help provided within the software.

- “Quick Start Guide” explains set up, enabling you to import songs to a computer, and to transfer them to the player.
- “Precautions” explains important notes to prevent accidents.
- “Troubleshooting” explains symptoms, causes and remedies when the player has problems.
- This “Operation Guide” explains standard and advanced features, enabling you to make full use of the player and troubleshoot problems.

Browsing the Operation Guide

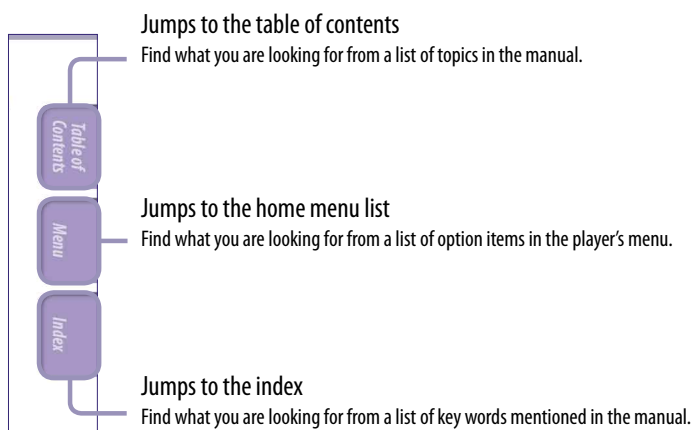

To use the buttons in the Operation Guide

Click the buttons located in the upper right of this manual to jump to Table of Contents, HOME Menu List, or Index.



Continued ↓

Hints

- You can jump to the indicated page by clicking a page number in the table of contents, in the home menu list, or in the index.
- You can jump to the indicated page by clicking a page reference indication (e.g.  page 4) on each page.
- To search for a reference page by keyword, click the “Edit” menu, select “Search” of the Adobe Reader to display the navigation frame, type the keyword into the Search text box, and click “Search.”
- Once you jump to another page, you can jump to the previous or next page by clicking the  or  button located at bottom of the Adobe Reader screen.
- Operation procedure may differ, depending on your Adobe Reader version.

To change the page layout

The buttons at the bottom of the Adobe Reader screen enable you to select how pages are displayed.

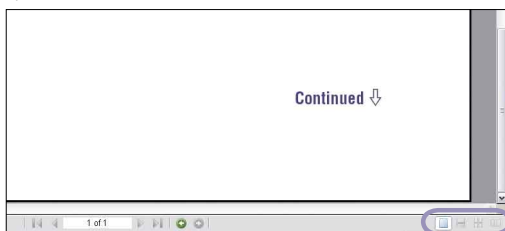

Single Page

Pages are displayed one at a time. When you scroll, the display changes to a previous or succeeding page.

Continuous

Pages are displayed as a continuous roll of pages. When you scroll, the previous or next pages scroll up or down continuously.

Continuous - Facing

Two pages are displayed side by side with each pair part of a continuous roll of pages. When you scroll, the previous and next pairs of pages scroll up or down continuously.

Facing

Two pages are displayed side by side. When you scroll, the display changes to previous or succeeding pairs of pages.

Table of Contents

HOME Menu List.....	6
Supplied Accessories.....	7
Changing the Style-Up* Panel	8
Parts and Controls.....	9
Front.....	9
Rear	11
Display.....	12

Getting Started

Preparing the Player	13
Charging the Player	13
Turning the Player On and Off.....	14
Getting Data	15
Transferring Data	16
Transferring music in Windows Explorer	16
Transferring music automatically using the “Auto Transfer” software	17
To delete music transferred to the player.....	18

Playing Music

Playing Music (All Songs)	19
Playing Songs in Random Order for a Specified Period of Time (Sports Shuffle).....	20
Searching for Songs (Search)	21
Changing the Play Mode (PLAY MODE)	22

Settings

Setting the File Display Language (File Disp Language)	23
Setting the Sound Quality (Sound)	25
Selecting the sound quality (Equalizer • Clear Bass)	25
Changing the sound quality (Equalizer)	26
Setting the EQ Custom values.....	28
Listening with Clear Stereo Sound (Clear Stereo).....	30
Adjusting the Volume Level (Dynamic Normalizer)	31
Changing the Display Mode (Display Mode)	32

Setting the Volume Level (Volume Mode).....	34
Setting to a Manual Volume (Manual Volume).....	34
Setting a Preset Volume (Preset Volume).....	35
Setting a Preset Volume value	36
Limiting the Volume (AVLS).....	37
Turning Off the Beep Sound (Beep)	38
Setting the Current Time (Set Date-Time)	39
Setting the Date Format (Date Disp Type).....	41
Setting the Time Format (Time Disp Type).....	42
Changing the USB Connection Setting (USB Bus Powered).....	43
Setting the Power Save Screen (Power Save Mode)	44
Setting the Contrast of the Display (Contrast)	45
Setting the Brightness of the Display (Brightness)	46
Displaying the Player Information (Information)	47
Resetting to Factory Settings (Reset All Settings)	48
Formatting Memory (Format).....	49

Listening to FM Radio

Listening to FM Radio	51
1 Switching to the FM radio.....	51
2 Presetting broadcast stations automatically (FM Auto Preset)	52
3 Selecting broadcast stations	53
Presetting Broadcast Stations Manually	55
Deleting preset broadcast stations	55
Setting the Reception (Scan Sens).....	56
Changing the Monaural/Stereo (Mono/Auto).....	57

Continued ↓

Useful Facts

Maximizing Battery Life	58
What are Format and Bit Rate?	59
What is audio format?	59
Storing Data Other than Audio Files.....	60
Upgrading the Player's Firmware	61

Troubleshooting

Troubleshooting.....	62
Messages	70

Additional Information

Precautions	72
About Copyrights	79
Specifications	80
Index	84

Note

- Depending on the country/region in which you have purchased the player, some models may not be available.

HOME Menu List

You can display the HOME menu by pressing and holding the /HOME button of the player.

The HOME menu is the starting point to play audio, search for songs, and change settings as follows.

Selectable menu items may differ, depending on the function or settings you use.

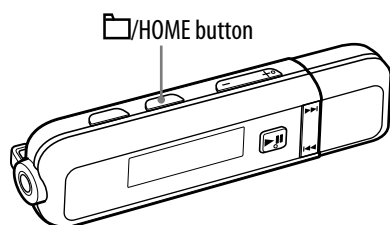

HOME menu*1



*1 5 icons appear in the display with the current selection in the center. The number of icons may differ depending on the function you use. By pressing the /▶▶ button, you can select an icon and press the ▶|| button to confirm.

 (Search) 21

 (Sports Shuffle) 20

 (All Songs) 19

 (FM) 51

(Settings)

File Disp Language.....	23
Sound.....	25
└ Equalizer.....	26
Clear Stereo.....	30
Display Mode.....	32
Scan Sens.....	56
Mono/Auto.....	57
FM Auto Preset.....	52
Advanced Settings	
└ Date-Time	
└ └ Set Date-Time.....	39
└ └ Date Disp Type.....	41
└ └ Time Disp Type.....	42
Power Save Mode.....	44
Dynamic Normalizer.....	31
AVLS.....	37
Volume Mode.....	34
Beep.....	38
Information.....	47
Initialize	
└ Reset All Settings.....	48
└ Format.....	49
USB Bus Powered.....	43
Contrast.....	45
Brightness.....	46

Supplied Accessories

Please check the accessories in the package.

- Headphones (1)
- Style-Up® Panel (1)
- USB cap for Style-Up® Panel (1)
- Quick Start Guide (1)
- Operation Guide (PDF file)*¹ (1)
- “Auto Transfer” software*² (1)

*¹ Operation Guide (PDF file) is stored in the built-in flash memory of the player.

*² The “Auto Transfer” software is stored in the built-in flash memory of the player. For details about this software, see “Transferring music automatically using the “Auto Transfer” software” (🔍 page 17).

About the serial number

The serial number provided for this player is required for the customer registration. The number is shown on the rear of the player.

You can also check the serial number on this player (🔍 page 47).

Continued ↓

Changing the Style-Up® Panel

You can select from a variety of Style-Up® Panel colors and matching USB cap.

- 1 Slide the **HOLD** switch in the direction of the arrow (▷) to deactivate the player, and then remove the USB cap.

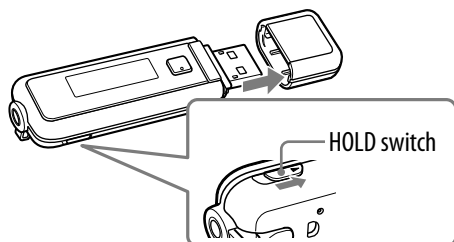

- 2 Remove the Style-Up® Panel as in the following illustrations. Slide the Style-Up® Panel in the direction of the arrow slightly, and remove.

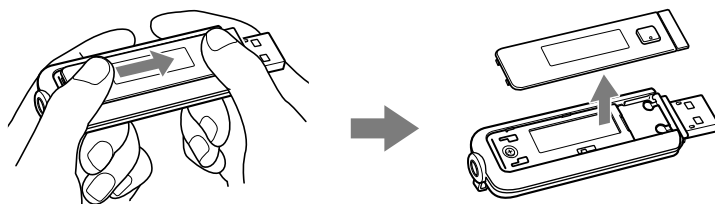

- 3 Attach the supplied Style-Up® Panel as in the following illustrations.

Place the supplied Style-Up® Panel on the front face of the player alongside the guide line, and then slide in to attach.

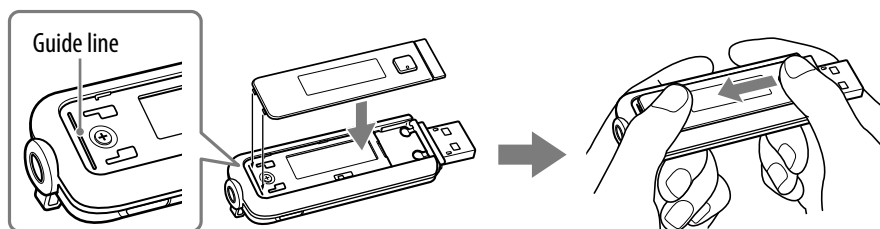

- 4 Attach the supplied matching USB cap.

Notes

- Be sure to attach the Style-Up® Panel when you use the player.
- Be sure to attach Style-Up® Panel properly. Otherwise, you may not be able to operate the buttons of the player properly.
- Handle the Style-Up® Panel with care. If the Style-Up® Panel becomes deformed, you may not be able to attach the Style-Up® Panel to the player or operate the buttons of the player.
- If dust or dirt gets on the Style-Up® Panel, remove with a dry cloth, etc.

Parts and Controls

Front

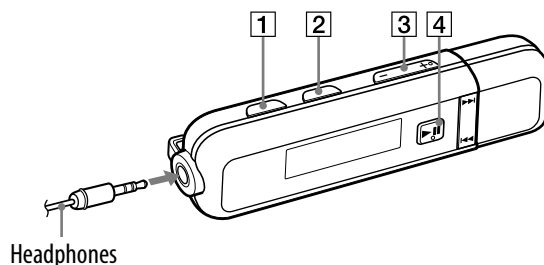

1 PLAY MODE/SOUND^{*1} button

Switches the play mode (☞ page 22). Press and hold this button to change the sound quality setting (☞ page 25).

2 HOME^{*1} button

When you press this button while playing or pausing a song, you can switch between Song control mode and Folder control mode. In Song control mode, the player skips to the beginning of the song. In Folder control mode, the player skips to the beginning of the folder.

You can check Song/Folder control mode by the 🎵 or 📁 icon, which appears in the display. Press and hold this button to display the HOME menu.

3 VOL +^{*2}/– button

Adjusts the volume.

4 ▶||^{*2} button

During playback, ▶ appears in the display. If this button is pressed again, || appears and playback pauses.

This button is also used to confirm menu items.

To turn off the power

When you pause song playback or FM reception by pressing the ▶|| button, after a few seconds, “POWER OFF” appears and the display goes off automatically, then the player enters Sleep status. The player consumes very little battery power in Sleep status. If you press any button, the player is turned on.

Continued ↓

^{*1} Functions marked with ● on the player are activated if you press the corresponding buttons.

Likewise functions marked with ● on the player are activated if you press and hold the corresponding buttons.

^{*2} There are tactile dots. Use them to help with button operations.

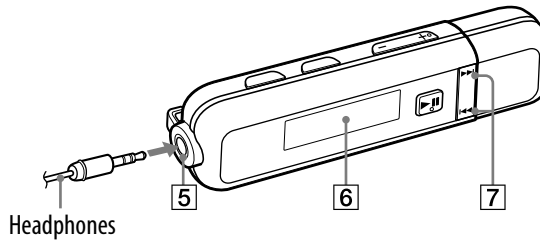

5 Headphone jack

For connecting the headphones. Insert the jack pin until it clicks into place. If the headphones are connected improperly, the sound from the headphones may not sound right.

6 Display

See  page 12.

7 ⏮/⏭ button

Selects a song, folder, or menu item. You can also skip to the beginning of the song/folder, or fast-forward or fast-rewind as follows.

- Pressing the ⏮ (⏭) button: Skips to the beginning of the current (or next) song/folder.
- Pressing and holding the ⏮ (⏭) button during playback and releasing it at the desired point in Song control mode: Fast-rewinds (or fast-forwards) the current song.
- Pressing and holding the ⏮ (⏭) button soon after entering pause mode: Skips to the beginning of the current (or next) song/folder, and if held longer, continues to skip through the previous (or next) song/folder.

Continued ↓

Rear

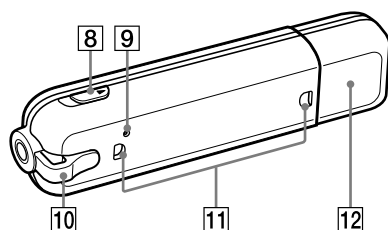

8 HOLD switch

You can protect the player against accidental operation by using the HOLD switch when carrying it. By sliding the HOLD switch to the direction of the arrow (▶), all operation buttons are disabled. If you press buttons while the HOLD function is activated, “HOLD” appears in the display. If you slide the HOLD switch to the opposite position, the HOLD function is released.

9 RESET button

Resets the player when you press the RESET button with a small pin, etc (☞ page 62).

10 Strap hole

Used to attach a strap (sold separately).

11 Accessory hole

Used to attach the optional accessories.

12 USB cap

Remove the USB cap and connect the USB connector of the player to a USB port on your computer.

To remove the USB cap

Remove the USB cap as shown below.

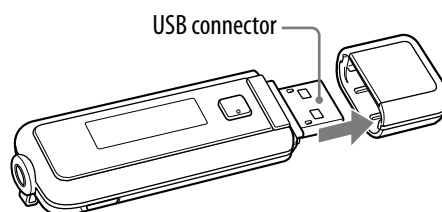

Continued ↓

Display

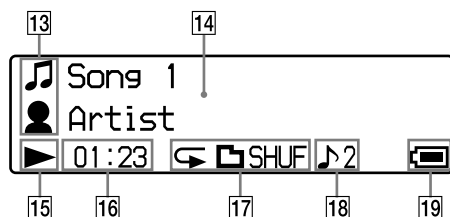

13 Icon indication

In Song control mode, 🎵 appears, in Folder control mode, 📁 appears on the 1st line. In either mode, 👤 appears on the 2nd line.

14 Text/graphic information display

Displays the song title, folder name, artist name, current date/time, messages and menu items.

To change the display mode, proceed to the “Display Mode” menu (🔗 page 32). Switch the display to power save mode if you do not intend to use the player for a while (🔗 page 44).

15 Playing status indication

Displays the current play mode (▶: playback, ⏸: pause, ⏮ (⏭): fast-rewinds (fast-forwards), ⏮ (⏭): skips to the beginning of the current (or next) song /folder).

16 Lapse time indication

Displays the elapsed time.

17 Play mode indication

Displays the current play mode icon (🔗 page 22). If the play mode is set to Normal, no icon appears.

18 Sound quality setting indication

Displays the current sound quality icon (🔗 page 25). If the sound quality is not set, no icon appears.

19 Remaining battery indication

Displays the remaining battery power.

💡 Hint

- For information on the FM radio display, see “Listening to FM Radio” (🔗 page 51).

Preparing the Player

Charging the Player

The player's battery is recharged while the player is connected to a running computer.

Remove the USB cap and connect the USB connector to a USB port on your computer.

When the remaining battery indication of the display shows: **Full**, charging is completed (charging time is approx. 60 minutes^{*1}).

When you use the player for the first time, or if you have not used the player for a long time, recharge it fully (until the **Full** battery indication is displayed).

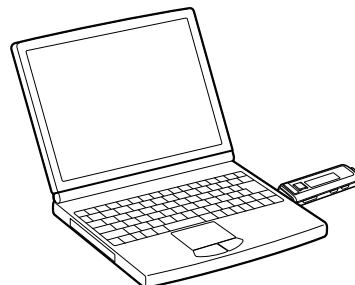

^{*1} This is the approximate charging time when the battery power is low and the “USB Bus Powered” setting (ⓘ page 43) is “High-Power 500mA” under room temperature. The charging time will vary depending on remaining battery power and battery condition. If the battery is charged in a low-temperature environment, the charging time will be longer. It will also be longer if you transfer audio file(s) to the player while charging.

Recharging the player

The battery icon in the display (ⓘ page 12) changes as shown below. See ⓘ page 82 on battery duration.



The battery power gets low as shown in the battery icon. If “LOW BATTERY” appears, you cannot operate with the player. In this case, charge the battery by connecting to your computer.

Continued ↓

Notes

- Charge the battery in an ambient temperature of between 5 to 35 °C (41 to 95 °F).
- The number of times the battery can be recharged before it is used up is approximately 500 times. This number may vary, depending on the conditions under which you use the player.
- The battery indicator on the display is only an estimation. For example, one section of black in the indicator will not always indicate exactly one-fourth of the battery's charge.
- "DATA ACCESS" appears in the display while the player accesses the computer. Do not disconnect the player while "DATA ACCESS" appears or the data being transferred may be damaged.
- The control buttons on the player are all disabled while it is connected to a computer.
- Some USB devices connected to the computer may interfere with proper operation of the player.
- We do not guarantee the recharge of the battery using personally assembled computers or modified computers.
- If the computer enters a power saving mode, such as the sleep or hibernation mode, even during USB connection, the player's battery is not charged. Instead, the player continues to draw power from the battery, discharging it.
- Do not leave the player connected for extended periods to a laptop computer that is not connected to AC power, because the player may discharge the computer's battery.

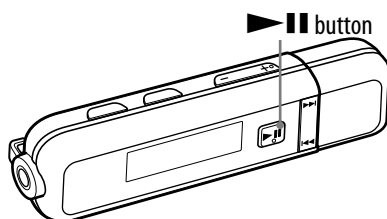
Turning the Player On and Off**To turn on the player**

Press any button to turn the player on.

To turn off the player

When you pause song playback or FM reception by pressing the ▶|| button, after a few seconds, "POWER OFF" appears and the display goes off automatically, then the player enters Sleep status. The player consumes very little battery power.

Getting Data

To enjoy audio data transferred to the player, you need to import audio data from the Internet or audio data from CDs to your computer before using the player. To import audio data from CDs, you need to use appropriate software for importing.

For details about supported file formats, see “Supported file format” (🔗 page 80).

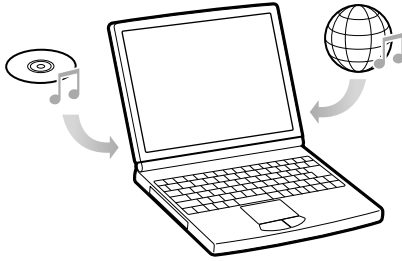

Transferring Data

You can directly transfer data by dragging and dropping in Windows Explorer on your computer. Be sure to transfer data into the “MUSIC” folder.

Playable data hierarchy has rules. To transfer data properly, read the following instructions.

You can also transfer data using the supplied “Auto Transfer” software (🔗 page 17).

Hint

- Data hierarchy may differ, depending on your computer environment.

Notes

- Do not disconnect the player while “DATA ACCESS” appears on the player as the data being transferred may be damaged.
- Do not delete or change the name of the “MUSIC” folder. Otherwise, songs will not be played back on the player.

Transferring music in Windows Explorer

1 Connect the USB connector of the player to your computer.

Insert the USB connector fully.

2 Select the player on Windows Explorer, and then drag and drop data.

The player appears on Windows Explorer as [WALKMAN] or [Removable Disk].

Data hierarchy

(On Windows Explorer)

Drag and drop files or folders into the “MUSIC” folder.

However, beyond the 8th level, neither files nor folders will be recognized.

For details on the order of song playback on the player, see 🔗 page 19.

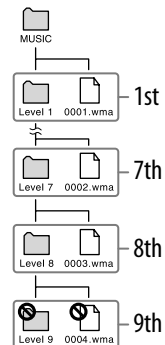

Continued ↓

Transferring music automatically using the “Auto Transfer” software

You can transfer audio files automatically from a desired folder every time you connect the player to your computer using the “Auto Transfer” software stored on the player.

When you use the “Auto Transfer” software for the first time, transfer audio files as follows.

1 Connect the player directly to a USB port on your computer.

If the screen for selecting what you want Windows to do appears, select [Launch Auto Transfer] and click [OK]. “Auto Transfer” stored in the built-in flash memory of the player starts up, and then go to the step 3.

2 Double-click [My Computer] - [WALKMAN] or [Removable Disk]

-  (AutoTransfer.exe).

3 Set the desired items on the “Settings” screen.

Automatic search folder

You can specify a folder as the automatic search folder when you connect the player to your computer. [My Music] and [Desktop] are specified (checked) by default. If you want to search audio files from folders other than [My Music] and [Desktop], select a folder to search from.

“Specified folder(s)”

Folders to be searched except for [My Music] and [Desktop] appear. When you click [Add], the folder select screen appears and you can add a folder that is in “Specified folder(s).” If you want to delete a folder from “Specified folder(s),” select it, and then click [Remove].

“Search all folders”

When you check [Search all folders and drives], audio files will be searched from the hard disk drive(s) and folders in your computer. If you check [Search all folders and drives], search time may increase.

“Advanced”

The “Advanced Settings” screen appears. You can specify the extension for an audio file or folder to be transferred. For details, see “Setting items of the “Advanced Settings” screen” (🔗 page 18).

4 Click [OK].

The screen for transfer appears and transfer starts.

When transferring completes, a message appears on the “Transfer log” section of the screen. Click  at the right of the screen to close.

To quit the “Auto Transfer” software

Even if you close the screen of “Auto Transfer” software, the “Auto Transfer” software will not be quit. To quit the “Auto Transfer” software, right-click the  icon from the notification area, at the lower right of Desktop, then select [Exit Application] from the menu.

When you connect the player to your computer after the first time

The screen for transfer appears and transfer starts. Only audio files that have not been transferred to the player are transferred.

Setting items of the “Advanced Settings” screen

You can set the following items on the “Advanced Settings” screen.

Set files/destination for transfer

- Extensions of audio files to be transferred and a list of destination folders appear.
 - [Add]
You can add an extension to an audio file to be transferred and the destination folder.
 - [Edit]
You can change the extension setting currently selected.
 - [Remove]
You can delete the extension currently selected.

Clear transfer history

- When you click [Clear], the history of the audio file transferred before by “Auto Transfer” is cleared. If you clear the history, when you connect the player to your computer next time, all audio files in “Specified folder(s)” are transferred to the player.

Hints

- To stop transferring audio files, click [Stop transfer] on the screen for transfer.
- When you click [Settings] on the screen for transfer, the “Settings” screen appears. When you click [Display destination folder], the root folder of the player ([WALKMAN] or [Removable Disk]) appears on Windows Explorer.

Note

- The “Auto Transfer” software is stored in the built-in flash memory of the player. If the built-in flash memory is formatted ( page 49), all files including the “Auto Transfer” software will be erased. Be sure to verify the data stored in memory prior to formatting, and export necessary data to the hard disk of your computer or other device. If you format the built-in flash memory of the player accidentally, download the “Auto Transfer” software from the following support web sites and store it in the built-in flash memory of the player.
 - For customers in Europe: <http://support.sony-europe.com/DNA>
 - For customers in Latin America: <http://www.sony-latin.com/index.crp>
 - For customers in other countries/regions: <http://www.sony-asia.com/support>
 - For customers who purchased the overseas models: <http://www.sony.co.jp/overseas/support/>

To delete music transferred to the player

Connect the player to your computer, and then delete any unnecessary audio files using Windows Explorer.

Playing Music (All Songs)

Songs transferred by the “Auto Transfer” software or Windows Explorer can be played back on the player.

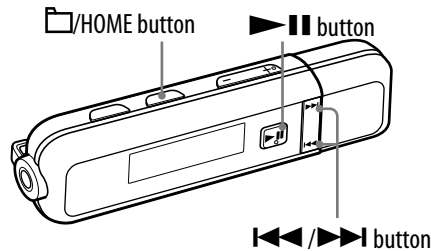



1 Press and hold the /HOME button until the HOME menu appears.



2 Press the  button to select  (All Songs), and then press the  button to confirm.

Playback starts from the last song you listened to. If you did not play any song, playback starts from the beginning.

Playback continues in order through the last song and then pauses. After a few seconds, “POWER OFF” appears, the display turns off automatically, and the player enters Sleep status.

To skip to the beginning of a song

By pressing the  () button while playing or pausing a song, the player skips to the beginning of the current (or next) song.

By pressing the /HOME button to change to the Folder control mode, and then pressing the  () button while playing or pausing a song, the player skips to the beginning of the first song of the current (or next) folder.

Hints

- Songs are played back on the player in the following order.
The files under the “MUSIC” folder at the 1st level are played back. And then the folders at the 1st level are selected in folder name order. When the folder is selected, the files under the selected folder are played back in file name order. Subsequent folders/files are similarly played back in hierarchical order. There is no case distinction between A to Z characters for folder/file names.
- You can change the play mode to random, repeat, etc., by pressing the PLAY MODE/SOUND button ( page 22).
- You can change the artist and song names on the property screen on your computer. When you did, transfer the audio files to the player again.
- If the song title and the artist name can be obtained from an audio file, they can be displayed on the playback screen. However, if the song title and the artist name cannot be obtained from the audio file, the file name is displayed instead of the song title, and “Unknown” is displayed instead of the artist name.
The player does not support all additional information formats of files.

Playing Songs in Random Order for a Specified Period of Time (Sports Shuffle)

The player randomly selects songs from all transferred songs and plays them in random order for a specified duration (between 1 and 99 minutes). “10 min” (10 minutes) is set by default.

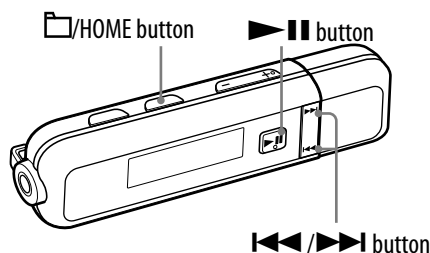

Note

- “Search” is not available while/after using this function or FM radio. If you want to use “Search” after this function or FM radio, operate from the HOME menu to select (All Songs) to confirm.

1 Press and hold the /HOME button until the HOME menu appears.

2 Press the button to select (Sports Shuffle), and then press the button to confirm.

The screen to select the playback time appears.

3 Press the button to select the playback time, and then press the button to confirm.

The selected playback time appears, and songs are randomly selected from all transferred songs and played back.

Elapsed time appears during playback. When the specified period passes, playback pauses. After a few seconds, “POWER OFF” appears, the display turns off automatically, and the player enters Sleep status.

Hints

- When the specified period has passed and playback pauses, then the button is pressed to start playback again, the player starts playback in random order for the specified period of time again.
- To stop “Sports Shuffle” and then start playing songs in another play mode, press and hold the /HOME button until the HOME menu appears and select (All Songs), and then press the button to play.

Notes

- The play mode automatically switches to the shuffle mode during “Sports Shuffle.”
- The display does not change to the one you set in “Display Mode” (page 32) during “Sports Shuffle.”

Searching for Songs (Search)

You can search for a song by its file name or its folder name. When you transfer audio data to the “MUSIC” folder using the “Auto Transfer” software or Windows Explorer, up to the 8th level under the “MUSIC” folder will appear on the player and can be played back.

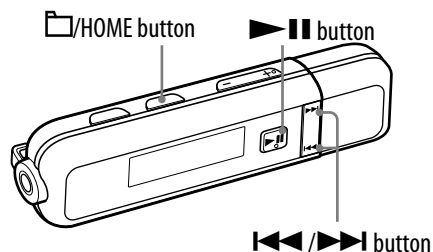

Notes

- This function is not available while/after using “Sports Shuffle” or FM radio. If you want to use this function after “Sports Shuffle” or FM radio, operate from the HOME menu to select 🎵 (All Songs) to confirm.
- The “MUSIC” folder does not appear, but data under the “MUSIC” folder appears on the player.

1 Press and hold the folder/Home button until the HOME menu appears.

2 Press the back/next button to select 🔍 (Search), and then press the play/pause button to confirm.

The folder list or the song appears.

3 Press the back/next button to select a folder or song, and then press the play/pause button to confirm.

When you select a folder, the song or folder list(s) appear. When you select a song, the playback screen appears, and then the song playback starts. Repeat step **3** if necessary until the desired song appears. The song you selected starts to play back and the playback of songs continues in order.

💡 Hints

- The play mode (⌂ page 22) does not change when 🔍 (Search) is activated.
- When you activate 🔍 (Search), the songs are displayed by the file name in the song list.

Changing the Play Mode (PLAY MODE)

The player offers a variety of play modes, including random play and selected repeat play.

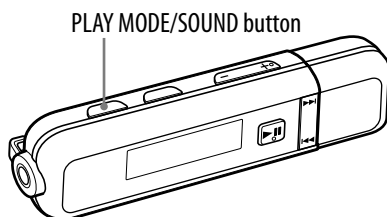

Note

- This function is not available while/after using “Sports Shuffle” or FM radio. If you want to use this function after “Sports Shuffle” or FM radio, operate from the HOME menu to select (All Songs) to confirm.

- 1 Press the **PLAY MODE/SOUND button** repeatedly to select the desired play mode.

List of play modes

Play mode type/Icon	Description
Normal/No icon	The current song is played, and then all transferred songs are played once. (Default setting)
Folder/	All transferred songs of the folder containing the current song are played once. In this case, songs/folders under the folder containing the current song cannot be played back.
Repeat All (all repeat)/	The current song is played, and then all transferred songs are played repeatedly.
Repeat Folder (folder repeat)/	All transferred songs of the folder containing the current song are played repeatedly. In this case, songs/folders under the folder containing the current song cannot be played back.
Repeat 1 Song (one song repeat)/ 1	The current song is played repeatedly.
Repeat Shuffle All (all song shuffle repeat)/ SHUF	The current song is played, and then all transferred songs are played in random order.
Repeat Shuffle Folder (folder shuffle repeat)/ SHUF	The current song is played, and then all transferred songs of the folder containing the current song are played in random order. In this case, songs/folders under the folder containing the current song cannot be played back.

Setting the File Display Language (File Disp Language)

You can select from 8 languages in which to display the transferred folder and audio file name.

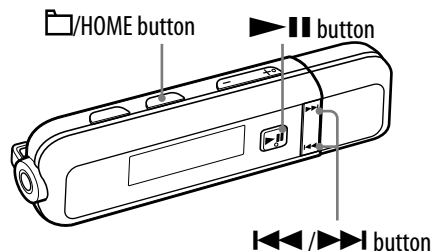

Notes

- This function is only available in pause mode.
- When the remaining battery is low, you cannot set this function. Charge the battery before setting.
- This function is not available while/after using FM radio. If you want to use this function after FM radio, operate from the HOME menu to select (All Songs) to confirm.
- Depending on the country/region in which you have purchased the player, the default setting may differ.

1 Press and hold the /HOME button until the HOME menu appears.

2 Press the button to select (Settings), and then press the button to confirm.

3 Press the button to select “File Disp Language>,” and then press the button to confirm.

The language list appears.

4 Press the button to select a language (page 24), and then press the button to confirm.

When you select a language other than one already set, “Create Database?” appears.

When you select the same language as before setting of step **4**, the screen returns to step **3**.

5 Press the button to select “OK,” and then press the button to confirm.

“ACCESS” appears and the database of the player updates.

To return to the previous menu

Press the /HOME button.

Display language settings

Setting	Description
English	Folders and audio files are displayed in English.
Español	Folders and audio files are displayed in Spanish.
Português	Folders and audio files are displayed in Portuguese.
Русский	Folders and audio files are displayed in Russian.
Українська	Folders and audio files are displayed in Ukrainian.
한국어	Folders and audio files are displayed in Korean.
简体中文	Folders and audio files are displayed in Simplified Chinese.
繁體中文	Folders and audio files are displayed in Traditional Chinese.

Notes

- After you select “OK” in step 5, it may take time until updating completes.
- If you display audio data that is not one of the 8 setting languages, “□” will be displayed instead of the audio data name.
- Audio data order may also change, depending on the language you set.

Setting the Sound Quality (Sound)

You can preset 2 sound quality settings and switch between them during playback or in pause mode by pressing and holding the PLAY MODE/SOUND button.

Furthermore, you can set the sound quality setting according to the music genre, etc., by selecting an “Equalizer” setting. If you set “Clear Bass,” you will hear clear sound without distortion. It is recommended to use “Clear Bass” when you adjust the volume up or emphasize the bass sound of “Equalizer.”

Selecting the sound quality (Equalizer • Clear Bass)

You can select preset sound quality settings from either “Equalizer” or “Clear Bass.”

Default settings

Sound quality (Indication)	Sound 1 (♪ 1)	Sound 2 (♪ 2)	Sound OFF (None)
Equalizer	EQ Custom (0, 0, 0, 0, 0)	EQ Custom (0, 0, 0, 0, 0)	Off
Clear Bass (bass)	+1	+3	0

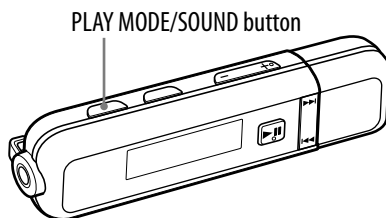

Note

- This function is not available while/after using FM radio. If you want to use this function after FM radio, operate from the HOME menu to select ♪ (All Songs) or 🎧 (Sports Shuffle) to confirm.

1 Press and hold the PLAY MODE/SOUND button.

Each time the button is pressed, the sound quality setting is changed as follows:

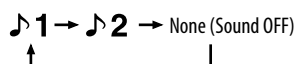

To return to normal sound quality

Select None (Sound OFF).

Changing the sound quality (Equalizer)

You can set your desired sound quality for each of “Sound1” and “Sound2,” according to the music genre, etc.

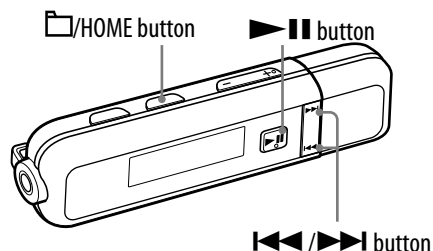

Note

- This function is not available while/after using FM radio. If you want to use this function after FM radio, operate from the HOME menu to select (All Songs) or (Sports Shuffle) to confirm.

- 1 Press and hold the /HOME button until the HOME menu appears.
- 2 Press the button to select (Settings), and then press the button to confirm.
- 3 Press the button to select “Sound>,” and then press the button to confirm.
- 4 Press the button to select “Equalizer>,” and then press the button to confirm.
- 5 Press the button to select “ Edit>” displayed under “Sound 1” or “Sound 2” to change, and then press the button to confirm.
The list of equalizer settings appears.
- 6 Press the button to select an Equalizer setting (page 27), and then press the button to confirm.

To return to the previous menu

Press the /HOME button.

Continued

List of Equalizer settings

Setting item	Description
EQ Heavy	Emphasizes high and low ranges for a powerful sound.
EQ Pop	Stresses the middle range audio, ideal for vocals.
EQ Jazz	Emphasizes high and low ranges for a lively sound.
EQ Unique	Emphasizes high and low ranges, so that a small sound can be listened easily.
EQ Custom	User-customizable sound settings. See  page 28 for setting. (Default setting)

Notes

- If the sound quality setting you select is distorted when you turn up the volume, turn it down.
- If your personal settings saved as “EQ Custom” seem to produce a different volume level than the other settings, you may have to adjust the volume manually to compensate.

Continued ↓

Setting the EQ Custom values

You can preset the value of “Clear Bass” (bass) and 5 bands “Equalizer” as “Sound1” or “Sound2” while looking at the player’s screen.

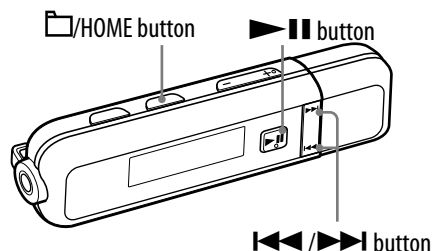

Notes

- If the “EQ Custom” value is set in “Equalizer” of the Setting menu, the “EQ Custom” setting is applied to the sound.
- This function is not available while/after using FM radio. If you want to use this function after FM radio, operate from the HOME menu to select 🎵 (All Songs) or 🏃 (Sports Shuffle) to confirm.

1 Press and hold the /HOME button until the HOME menu appears.

2 Press the button to select (Settings), and then press the button to confirm.

3 Press the button to select “Sound>,” and then press the button to confirm.

4 Press the button to select “Equalizer>,” and then press the button to confirm.

5 Press the button to select “^LEdit>” displayed under “Sound 1” or “Sound 2” to change, and then press the button to confirm.

The list of equalizer settings appears.

Continued ↓

-
- 6 Press the |◀◀/▶▶| button to select “L Edit>” displayed under “EQ Custom,” and then press the ▶|| button to confirm.**

The slider of “Clear Bass” appears highlighted.
“Clear Bass” can be set to one of 4 sound levels.

- 7 Press the |◀◀/▶▶| button to set the “Clear Bass” value, and then press the ▶|| button to confirm.**

The slider of “Equalizer” appears highlighted.
“Equalizer” can be set to one of 7 sound levels.

- 8 Press the |◀◀/▶▶| button to select the “Equalizer” value, and then press the ▶|| button to confirm.**
-

To return to the previous menu

Press the /HOME button.

Listening with Clear Stereo Sound (Clear Stereo)

“Clear Stereo” enables individual left and right digital processing of the sound.

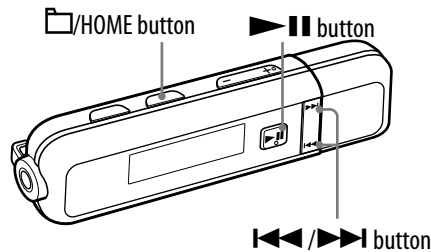

Note

- This function is not available while/after using FM radio. If you want to use this function after FM radio, operate from the HOME menu to select 🎵 (All Songs) or 🎧 (Sports Shuffle) to confirm.

- 1 Press and hold the /HOME button until the HOME menu appears.
- 2 Press the button to select (Settings), and then press the button to confirm.
- 3 Press the button to select “Clear Stereo>,” and then press the button to confirm.
- 4 Press the button to select the setting, and then press the button to confirm.
 - “Clear Stereo ON”: Activates the “Clear Stereo” function when you use the supplied headphones. (Default setting)
 - “Clear Stereo OFF”: Disables the “Clear Stereo” function and plays back normal sound.

To return to the previous menu

Press the /HOME button.

Note

- The “Clear Stereo” function is set to obtain maximum effect with the supplied headphones. The “Clear Stereo” effect may not be obtained with other headphones. In this case, set “Clear Stereo” to “Clear Stereo OFF.”

Adjusting the Volume Level (Dynamic Normalizer)

You can set to reduce the volume level between songs. With this setting, when listening to folder songs in the shuffle play mode, the volume level between songs is moderated to minimize differences in recorded level.

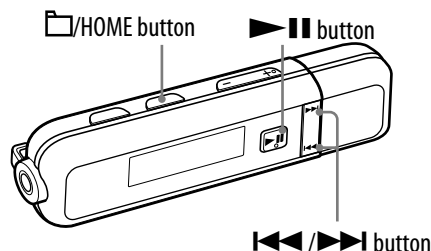

Note

- This function is not available while/after using FM radio. If you want to use this function after FM radio, operate from the HOME menu to select (All Songs) or (Sports Shuffle) to confirm.

- 1 Press and hold the /HOME button until the HOME menu appears.
- 2 Press the to select (Settings), and then press the to confirm.
- 3 Press the to select “Advanced Settings>,” and then press the to confirm.
- 4 Press the to select “Dynamic Normalizer>,” and then press the to confirm.
- 5 Press the to select the setting, and then press the to confirm.
 - “D. Normalizer ON”: Minimizes the difference of the volume level between songs.
 - “D. Normalizer OFF”: Plays back songs with their original volume level as transferred. (Default setting)

To return to the previous menu

Press the /HOME button.

Changing the Display Mode (Display Mode)

You can change the display in play or pause mode.

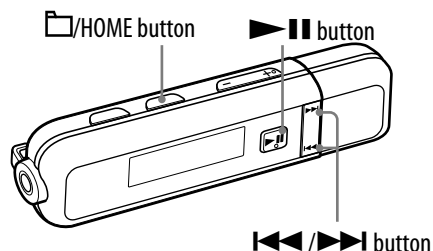

Note

- This function is not available while/after using FM radio. If you want to use this function after FM radio, operate from the HOME menu to select (All Songs) to confirm.

- 1 Press and hold the /HOME button until the HOME menu appears.
- 2 Press the button to select (Settings), and then press the button to confirm.
- 3 Press the button to select "Display Mode>," and then press the button to confirm.
- 4 Press the button to select the display (page 33), and then press the button to confirm.

To return to the previous menu

Press the /HOME button.

Continued ↓

List of display types

- “Basic”: The basic display (Default setting)
- “Property”: Song information
Displays the current play mode, the current folder number/total folder number of the playback range, the current song number/total song number of the playback range, **< L R >** (Clear Stereo icon,  page 30), codec (audio format), and bit rate.





- “Clock”: Time information
Displays the year, month, date, and current time. For information on setting the time, see “Setting the Current Time (Set Date-Time)” ( page 39).

Hint

- Set “Power Save Mode” ( page 44) to “Save OFF” to show the screen constantly.

Notes

- When the “Clear Stereo” function ( page 30) is set to “OFF,” icons do not appear on the “Property” screen.
- The display does not change to the one you set in “Display Mode” during “Sports Shuffle” ( page 20) or FM reception ( page 51).

Setting the Volume Level (Volume Mode)

There are 2 modes to adjust the volume level.

Manual Volume (Default setting):







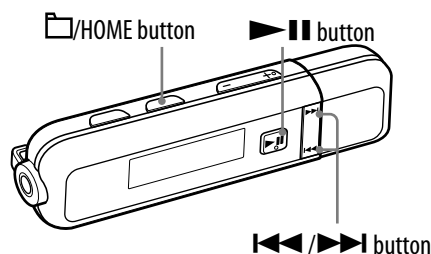



Press the VOL +/- button to adjust the volume level between 0 to 30.

Preset Volume:

Press the VOL +/- button to set the volume level to one of 3 preset levels: “Low,” “Mid,” or “High.”



Setting to a Manual Volume (Manual Volume)

- 1 Press and hold the /HOME button until the HOME menu appears.
- 2 Press the  button to select  (Settings), and then press the  button to confirm.
- 3 Press the  button to select “Advanced Settings>,” and then press the  button to confirm.
- 4 Press the  button to select “Volume Mode>,” and then press the  button to confirm.
- 5 Press the  button to select “Manual Volume,” and then press the  button to confirm.











With this setting, you can adjust the volume between 0 to 30 by pressing the VOL +/- button.

To return to the previous menu

Press the /HOME button.

Continued 

Setting a Preset Volume (Preset Volume)

- 1 Press and hold the /HOME button until the HOME menu appears.
- 2 Press the /▶▶▶ button to select  (Settings), and then press the  button to confirm.
- 3 Press the /▶▶▶ button to select “Advanced Settings>,” and then press the  button to confirm.
- 4 Press the /▶▶▶ button to select “Volume Mode>,” and then press the  button to confirm.
- 5 Press the /▶▶▶ button to select “Preset Volume,” and then press the  button to confirm.

With this setting, you can select the volume level (“Low,” “Mid,” or “High”) by pressing the VOL +/- button.

To return to the previous menu













Press the /HOME button.

Note

- If “AVLS” ( page 37) is set, the actual volume may be lower than the settings. Releasing “AVLS” (AVLS OFF) returns the volume to the preset level.

Continued 

Setting a Preset Volume value

- 1 Press and hold the /HOME button until the HOME menu appears.
- 2 Press the /▶▶▶ button to select  (Settings), and then press the  button to confirm.
- 3 Press the /▶▶▶ button to select “Advanced Settings>,” and then press the  button to confirm.
- 4 Press the /▶▶▶ button to select “Volume Mode>,” and then press the  button to confirm.
- 5 Press the /▶▶▶ button to select “^LEdit>” displayed under “Preset Volume,” and then press the  button to confirm.
The “Low” value appears selected.
- 6 Press the /▶▶▶ button to set each value for “Low,” “Mid” or “High,” and then press the  button to confirm.
With this setting, you can select the set value of the volume level (“Low,” “Mid,” or “High”) by pressing the VOL +/- button.

To return to the previous menu

Press the /HOME button.









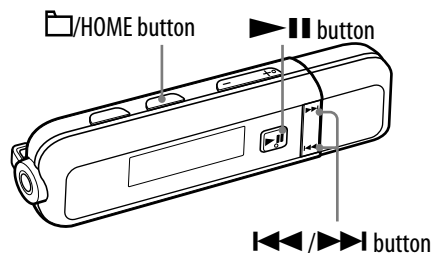

Note

- If “AVLS” ( page 37) is set, the actual volume may be lower than the settings. Releasing “AVLS” (AVLS OFF) returns the volume to the preset level.

Limiting the Volume (AVLS)

You can set “AVLS” (Automatic Volume Limiter System) to limit the maximum volume to prevent auditory disturbance or distraction. With “AVLS”, you can listen to music at a comfortable volume level. “AVLS OFF” is set by default.



- 1 Press and hold the /HOME button until the HOME menu appears.
- 2 Press the  button to select  (Settings), and then press the  button to confirm.
- 3 Press the  button to select “Advanced Settings>,” and then press the  button to confirm.
- 4 Press the  button to select “AVLS>,” and then press the  button to confirm.
- 5 Press the  button to select “AVLS ON,” and then press the  button to confirm.

The volume is kept at a moderate level.

To set to off

Select “AVLS OFF” in step 5, and press the  button to confirm.

To return to the previous menu

Press the /HOME button.









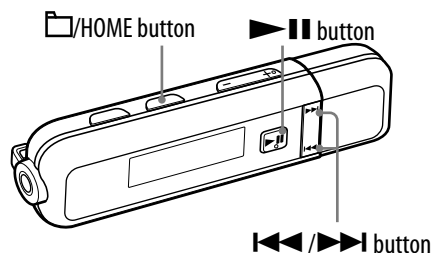

Hint

- “AVLS” appears by pressing the VOL +/- button if “AVLS” is set to “AVLS ON.”

Turning Off the Beep Sound (Beep)

You can turn off the beep sounds of the player. “Beep ON” is set by default.



- 1 Press and hold the /HOME button until the HOME menu appears.
- 2 Press the  button to select  (Settings), and then press the  button to confirm.
- 3 Press the  button to select “Advanced Settings>,” and then press the  button to confirm.
- 4 Press the  button to select “Beep>,” and then press the  button to confirm.
- 5 Press the  button to select “Beep OFF,” and then press the  button to confirm.

To change the setting to on

Select “Beep ON” in step 5, and press the  button to confirm.









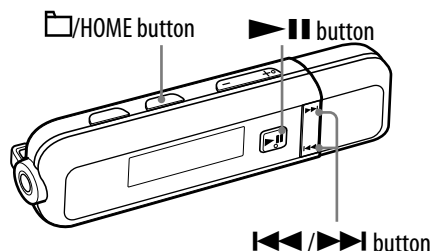



To return to the previous menu

Press the /HOME button.

Setting the Current Time (Set Date-Time)

You can set the current time by adjusting it manually.



- 1 Press and hold the /HOME button until the HOME menu appears.
- 2 Press the  button to select  (Settings), and then press the  button to confirm.
- 3 Press the  button to select "Advanced Settings>," and then press the  button to confirm.
- 4 Press the  button to select "Date-Time>," and then press the  button to confirm.
- 5 Press the  button to select "Set Date-Time>," and then press the  button to confirm.
The year value appears selected.
- 6 Press the  button to adjust the year setting, and then press the  button to confirm.
The month value appears selected.
- 7 As you did in step 6, adjust the settings for month, date, hour, and minute, and then press the  button to confirm.

Continued 

To return to the previous menu



Press the /HOME button.

To display the current time

You can display the current time in either of the following ways:

- Set “Clock” in “Changing the Display Mode (Display Mode)” ( page 32).
- While the HOLD function is activated, press any button.

Hint

- You can select the date format: year/month/day, day/month/year, or month/day/year. Furthermore, you can select the time format displayed for the current time from either a “Time 24h” or “Time 12h” display. For details, see “Setting the Date Format (Date Disp Type)” ( page 41), or “Setting the Time Format (Time Disp Type)” ( page 42).

Notes

- If the player is not used for a long time, your settings for date and time may need to be set again.
- If the current time is not set and the display is set to “Clock” ( page 33), “--” appears. If you press a button while the HOLD function is activated, the time will not appear.
- The clock may develop an inaccuracy of up to 120 seconds per month (at 25 °C (77 °F)). In this case, set the current time again.

Setting the Date Format (Date Disp Type)

You can select the date format displayed for the current time (☞ page 39) from among year/month/day, day/month/year, and month/day/year.

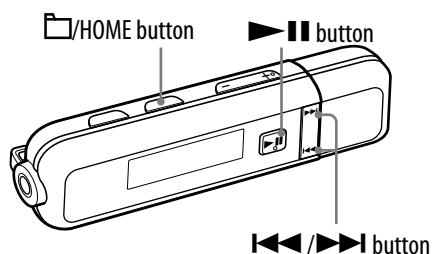

- 1 Press and hold the /HOME button until the HOME menu appears.
- 2 Press the button to select (Settings), and then press the button to confirm.
- 3 Press the button to select "Advanced Settings>," and then press the button to confirm.
- 4 Press the button to select "Date-Time>," and then press the button to confirm.
- 5 Press the button to select "Date Disp Type>," and then press the button to confirm.
The screen used to set the display format appears.

- 6 Press the button to select the format, and then press the button to confirm.

You can select the format from the following 3 types.

- "Date yy/mm/dd": The date appears as year/month/day. (Default setting)
- "Date dd/mm/yy": The date appears as day/month/year.
- "Date mm/dd/yy": The date appears as month/day/year.









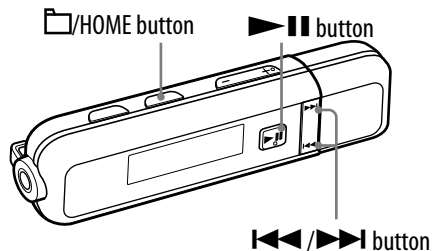



To return to the previous menu

Press the /HOME button.

Setting the Time Format (Time Disp Type)

You can select the time format displayed for the current time (📄 page 39) from either a “Time 24h” or “Time 12h” display.



- 1 Press and hold the /HOME button until the HOME menu appears.
- 2 Press the  button to select  (Settings), and then press the  button to confirm.
- 3 Press the  button to select “Advanced Settings>,” and then press the  button to confirm.
- 4 Press the  button to select “Date-Time>,” and then press the  button to confirm.
- 5 Press the  button to select “Time Disp Type>,” and then press the  button to confirm.
The screen used to set the display format appears.
- 6 Press the  button to select the setting, and then press the  button to confirm.
 - “Time 24h”: Displays a 24 hour display. (Default setting)
 - “Time 12h”: Displays a 12 hour display.

To return to the previous menu

Press the /HOME button.

Changing the USB Connection Setting (USB Bus Powered)

Depending on how you are using the computer, if the power supply (USB Bus Power) is insufficient, incomplete data transfer may occur from the computer to the player. In this case, setting the USB connection (USB Bus Powered) to “Low-Power 100mA” may improve data transfer.

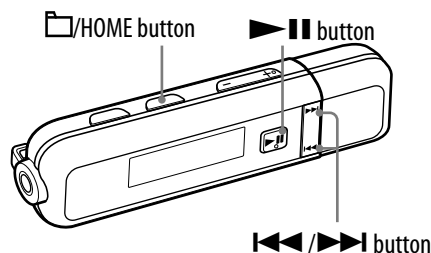

Note

- You cannot set this during USB connection.

- 1 Press and hold the /HOME button until the HOME menu appears.
- 2 Press the button to select (Settings), and then press the button to confirm.
- 3 Press the button to select “Advanced Settings>,” and then press the button to confirm.
- 4 Press the button to select “USB Bus Powered>,” and then press the button to confirm.
- 5 Press the button to select the setting, and then press the button to confirm.
 - “High-Power 500mA”: Sets the power rating from computer to 500mA. (Default setting)
 - “Low-Power 100mA”: Sets the power rating from computer to 100mA.

To return to the previous menu

Press the /HOME button.









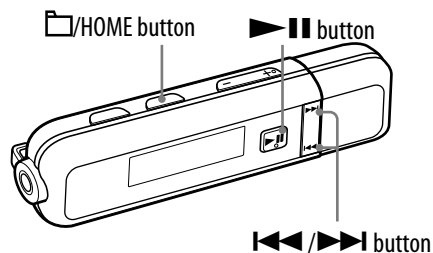

Hints

- When you connect the player to a laptop computer, we recommend to connect the laptop computer to AC power.
- The charging time will be longer if the “USB Bus Powered” is set to “Low-Power 100mA.”

Setting the Power Save Screen (Power Save Mode)

When you do not operate the player for a specified duration (about 15 seconds), the screen will change to the power save screen. You can change the power save screen settings.



- 1 Press and hold the /HOME button until the HOME menu appears.
- 2 Press the  button to select  (Settings), and then press the  button to confirm.
- 3 Press the  button to select "Advanced Settings>," and then press the  button to confirm.
- 4 Press the  button to select "Power Save Mode>," and then press the  button to confirm.
- 5 Press the  button to select the power save setting, and then press the  button to confirm.

To return to the previous menu

Press the /HOME button.

List of the power save settings

Setting item	Description
Save ON Normal	The power save screen appears in the display when no operation is performed for about 15 seconds. (Default setting)
Save ON Super	The screen disappears when no operation is performed for about 15 seconds. This setting uses the least battery consumption.
Save OFF	The icon(s) or letter(s) appears in the display constantly during playback or FM reception.

Setting the Contrast of the Display (Contrast)

You can set the display contrast to one of 15 levels. “0” is set by default.

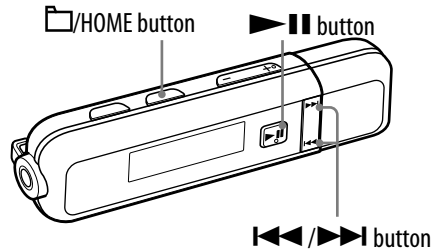

- 1 Press and hold the HOME button until the HOME menu appears.**
- 2 Press the Navigation button to select Settings, and then press the Confirm button to confirm.**
- 3 Press the Navigation button to select “Advanced Settings>,” and then press the Confirm button to confirm.**
- 4 Press the Navigation button to select “Contrast>,” and then press the Confirm button to confirm.**

The contrast adjustment screen appears.
- 5 Press the Navigation button to adjust the contrast level, and then press the Confirm button to confirm.**









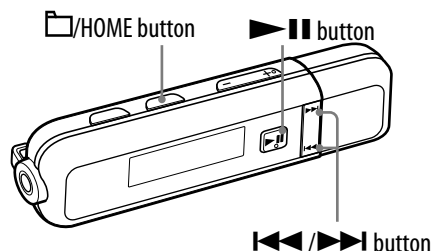

To return to the previous menu

Press the HOME button.

Setting the Brightness of the Display (Brightness)

You can set the display brightness level from 1 to 7. “4” is set by default.



- 1 Press and hold the /HOME button until the HOME menu appears.
- 2 Press the  button to select  (Settings), and then press the  button to confirm.
- 3 Press the  button to select “Advanced Settings>,” and then press the  button to confirm.
- 4 Press the  button to select “Brightness>,” and then press the  button to confirm.
- 5 Press the  button to adjust the brightness level, and then press the  button to confirm.

To return to the previous menu

Press the /HOME button.

Note

- You can only set the brightness of the screen for during operation. It is not possible to set brightness during idle periods when the player is not being operated.

Displaying the Player Information (Information)

Information such as model name, built-in flash memory capacity, serial number, and firmware version can be displayed.

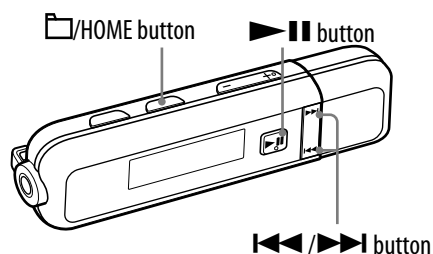

- 1 Press and hold the /HOME button until the HOME menu appears.
- 2 Press the button to select (Settings), and then press the button to confirm.
- 3 Press the button to select "Advanced Settings>," and then press the button to confirm.
- 4 Press the button to select "Information>," and then press the button to confirm.

You can check the following information by pressing the button to scroll through.

- 1: model name
- 2: built-in flash memory capacity
- 3: serial number
- 4: version information for the player's firmware

To return to the previous menu

Press the /HOME button.

Resetting to Factory Settings (Reset All Settings)

You can reset the player to the default settings. Resetting the player does not delete the songs you have transferred to the player.

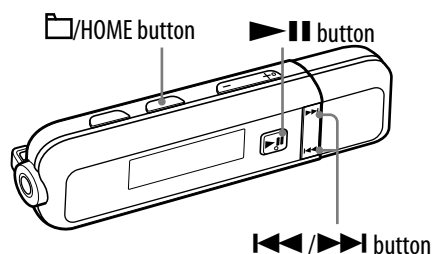

Notes

- This function is only available in pause mode.
- This function is not available while/after using FM radio. If you want to use this function after FM radio, operate from the HOME menu to select (All Songs) or (Sports Shuffle) to confirm.

- 1 Press and hold the /HOME button in pause mode until the HOME menu appears.
- 2 Press the button to select (Settings), and then press the button to confirm.
- 3 Press the button to select "Advanced Settings>," and then press the button to confirm.
- 4 Press the button to select "Initialize>," and then press the button to confirm.
- 5 Press the button to select "Reset All Settings>," and then press the button to confirm.
- 6 Press the button to select "OK," and then press the button to confirm.
 "COMPLETE" appears and the player is reset to the default settings.
 "ACCESS" appears and when you start playback, the starting point will be the first song of all songs (page 19).

To cancel the operation

Select "Cancel" in step 6, and press the button to confirm.

To return to the previous menu

Press the /HOME button.

Formatting Memory (Format)

You can format the built-in flash memory of the player.

If the built-in flash memory is formatted, all audio data, the “Auto Transfer” software and Operation Guide (this manual) will be erased. Be sure to verify the data stored in the memory prior to formatting, and export any necessary data to the hard disk of your computer or other device.

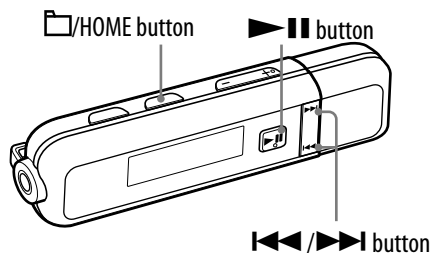

Notes

- This function is only available in pause mode.
- When the remaining battery is low, you cannot format the player. Charge the battery before formatting.
- This function is not available while/after using FM radio. If you want to use this function after FM radio, operate from the HOME menu to select (All Songs) or (Sports Shuffle) to confirm.
- If you format the built-in flash memory of the player, data in the “MUSIC” folder is erased, but the “MUSIC” folder is left on the player.

- 1 Press and hold the /HOME button in pause mode until the HOME menu appears.
- 2 Press the button to select (Settings), and then press the button to confirm.
- 3 Press the button to select “Advanced Settings>,” and then press the button to confirm.
- 4 Press the button to select “Initialize>,” and then press the button to confirm.
- 5 Press the button to select “Format>,” and then press the button to confirm.
- 6 Press the button to select “OK,” and then press the button to confirm.
 “FORMATTING...” appears and formatting starts.
 When formatting is completed, “COMPLETE” appears.

To cancel the operation

Select “Cancel” in step 6, and press the ►|| button to confirm.

To return to the previous menu

Press the □/HOME button.

Note

- Do not format the built-in flash memory of the player in Windows Explorer. When you formatted the player in Windows Explorer accidentally, do it again on the player (🔗 page 49).

Listening to FM Radio

You can listen to FM radio. The headphone cord works as an antenna. Use the player with the headphone cord extended.

1 Switching to the FM radio

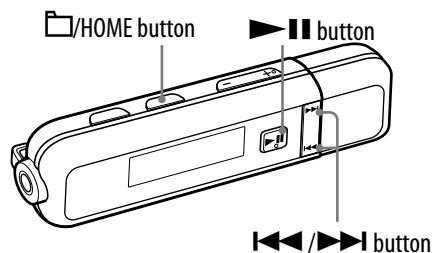

1 Press and hold the HOME button until the HOME menu appears.

2 Press the Previous/Next button to select FM (FM), and then press the Play/Pause button to confirm.

The FM radio screen appears.

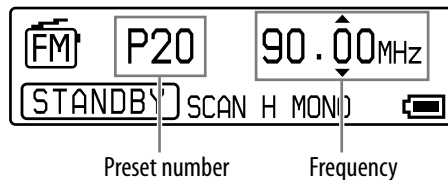





Preset number

Frequency



Depending on the country/region in which you have purchased the player, the screen appearance may differ.

Continued ↓



To stop the FM radio and return to the audio player

Press and hold the /HOME button until the HOME menu appears, and then select  (All Songs) or  (Sports Shuffle) from the menu screen and press the  button to play back.

To turn off the volume of the FM radio briefly

By pressing the  button, FM radio sound is not output. The FM radio enters Sleep status after a few seconds and the display goes off. By pressing the  button again, FM radio sound is output again.

Notes

- When you press the  button while the player is in the Sleep status, the previous (or next) preset number or frequency is selected. At that time, the sound is not output, regardless of the VOL +/- button.
- The display does not change to the one you set in “Display Mode” ( page 32) during FM reception.





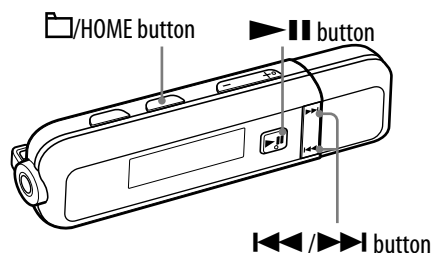

2 Presetting broadcast stations automatically (FM Auto Preset)

You can preset receivable broadcast stations (up to 30 stations) in your area automatically by selecting “FM Auto Preset.” When you use the FM radio for the first time, or when you move to a new area, we recommend to preset receivable broadcast stations by selecting “FM Auto Preset.”



Note

- The “FM Auto Preset” operation will delete already preset broadcast stations.

- 1 Press and hold the /HOME button while displaying the FM radio screen until the HOME menu appears.**
- 2 Press the  button to select  (Settings), and then press the  button to confirm.**
- 3 Press the  button to select “FM Auto Preset>,” and then press the  button to confirm.**

- 4 Press the **◀◀/▶▶** button to select “OK,” and then press the **▶||** button to confirm.

The receivable broadcast stations will be preset in order from low to high frequency.

“COMPLETE” appears when presetting is completed, then the first preset station is received.

To stop automatic presetting

Select “Cancel” in step 4, and press the **▶||** button to confirm.

To return to the previous menu

Press the **□**/HOME button.

If several unnecessary stations are received

If interference is prevalent or reception is too sensitive, change the reception setting (**Ⓒ** page 56) to “Scan Sens Low.”

3 Selecting broadcast stations

There are 2 ways (preset or manual tuning) to select broadcast stations.

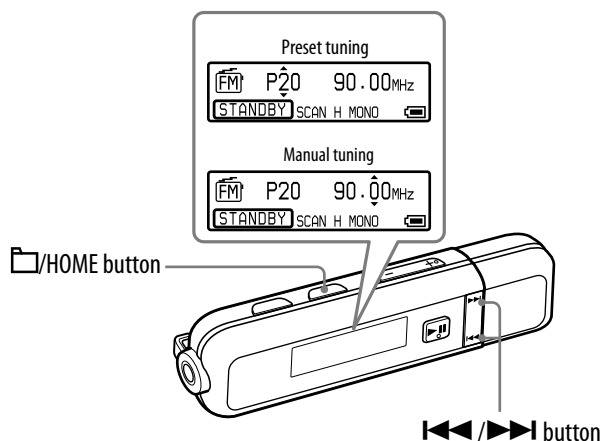

By pressing the **□**/HOME button, the player enters the preset tuning mode. To switch from preset tuning mode to manual tuning mode, press the **□**/HOME button again.

• Preset Tuning

In the preset tuning mode, you can select broadcast stations by preset number.

• Manual Tuning

In the manual tuning mode, you can select broadcast stations by frequency.

Continued ↓

Preset Tuning

Preset number appears with ▲ and ▼ above and below.

To	Operation
Select the previous preset number	Press the ◀◀ button briefly.
Select the next preset number	Press the ▶▶ button briefly.

Note

- You cannot select broadcast stations if no preset stations are entered. Preset the receivable stations using “FM Auto Preset” (🔧 page 52).

Manual Tuning

Frequency appears with ▲ and ▼ above and below.

To	Operation
Select the previous frequency	Press the ◀◀ button briefly.
Select the next frequency	Press the ▶▶ button briefly.
Select the previous receivable broadcast station* ¹	Press and hold the ◀◀ button.
Select the next receivable broadcast station* ¹	Press and hold the ▶▶ button.

*¹By pressing and hold the ◀◀ (▶▶) button during FM reception, the previous (or next) broadcast station is found. If the broadcast station is receivable, the reception is accepted.

If interference is prevalent or reception is too sensitive, change the reception setting (🔧 page 56) to “Scan Sens Low.”

If you press the ◀◀ (▶▶) button in the Sleep status, the frequency decreases (or increases), but the previous (or next) broadcast station is not found and sound is not output.

💡 Improving the reception

- The headphone cord serves as the antenna, so extend it as far as possible.

Presetting Broadcast Stations Manually

You can preset broadcast stations which “FM Auto Preset” cannot detect (☞ page 52).

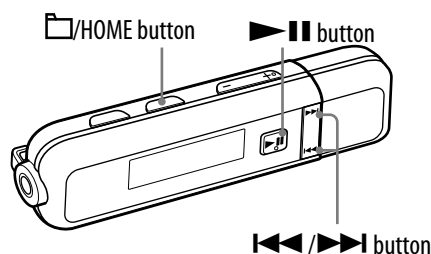

- 1 **Select the desired frequency by the manual tuning mode** (☞ page 53).
- 2 **Press and hold the ▶ || button.**
The frequency you select in step 1 is preset and the assigned preset number appears to the left of the frequency.

Hint

- You can preset up to 30 stations (P01 to P30).

Note

- The preset numbers are stored in order, from low to high frequency.

Deleting preset broadcast stations

- 1 **Select the preset number of the frequency to delete.**
- 2 **Press and hold the ▶ || button.**
- 3 **Press the ◀◀ / ▶▶ button to select “OK,” and then press the ▶ || button to confirm.**
The preset broadcast station is deleted and the next one appears.







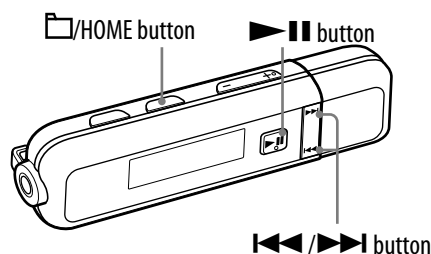

To cancel deletion of the preset broadcast station

Select “Cancel” in step 3, and press the ▶ || button to confirm.

Setting the Reception (Scan Sens)

When you select stations using the “FM Auto Preset” function (📶 page 52) or “Manual Tuning” (📶 page 53), the FM receiver may receive many unwanted broadcast stations because the reception is too sensitive. In this case, set the reception to “Scan Sens Low.” “Scan Sens High” is set by default.



- 1 Press and hold the /HOME button while displaying the FM radio screen until the HOME menu appears.
- 2 Press the  button to select  (Settings), and then press the  button to confirm.
- 3 Press the  button to select “Scan Sens>,” and then press the  button to confirm.
- 4 Press the  button to select “Scan Sens Low,” and then press the  button to confirm.

To set the reception sensitivity back to the default

Select “Scan Sens High” in step 4, and press the  button to confirm.







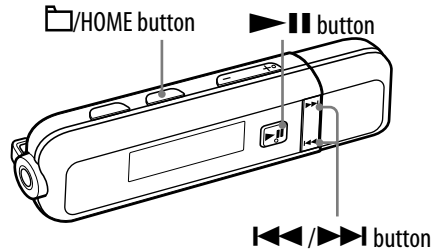

To return to the previous menu

Press the /HOME button.

Changing the Monaural/Stereo (Mono/Auto)

If noise occurs during FM reception, set the receiver to “Mono” for monaural. If you set it to “Auto,” monaural/stereo reception is selected automatically, depending on reception conditions. “Auto” is set by default.



- 1 Press and hold the /HOME button while displaying the FM radio screen until the HOME menu appears.
- 2 Press the  button to select  (Settings), and then press the  button to confirm.
- 3 Press the  button to select “Mono/Auto>,” and then press the  button to confirm.
- 4 Press the  button to select “Mono,” and then press the  button to confirm.

To return to the automatic setting

Select “Auto” in step 4, and press the  button to confirm.

To return to the previous menu

Press the /HOME button.

Maximizing Battery Life

By adjusting the settings or managing the power supply properly, it is possible to save battery power and use the player for a longer time.

To enter the Sleep status

If you press the ►|| button to pause playback or receiving an FM broadcast, after “POWER OFF” appears, the display disappears and the player enters the Sleep status automatically after a few seconds. The batteries are consumed a little in the Sleep status.

Changing the settings

You can save battery power by setting as follows.

Settings for screen	“Power Save Mode>” (☞ page 44)	“Save ON Super”
	“Brightness>” (☞ page 46)	“1”
Settings for sound effect	Sound quality (☞ page 25)	Deactivate
	“Clear Stereo>” (☞ page 30)	
	“Dynamic Normalizer>” (☞ page 31)	

Adjust data format and bit rate

Playing time will vary, as battery charge can be affected by the format and bit rate of songs that are played.

For details on charging time and usage time, see ☞ pages 81 and 82.

What are Format and Bit Rate?

What is audio format?

Audio format refers to the method used when importing audio data from the Internet or audio CDs to a computer and saving it as an audio file.

Common formats include MP3 and WMA, etc.

MP3: MP3 (MPEG-1 Audio Layer3) is a common audio compression technology developed by the MPEG working group of the ISO (International Organization for Standardization).

MP3 can compress audio files to about 1/10 the size of standard CD audio files.

WMA: WMA (Windows Media Audio) is a common audio compression technology developed by Microsoft Corporation. WMA format produces the same sound quality as that of MP3 format with smaller file size.

AAC: AAC (Advanced Audio Coding) is a common audio compression technology developed by the MPEG working group of the ISO (International Organization for Standardization). AAC format produces the same sound quality as that of MP3 format, with a smaller file size.

Linear-PCM: Linear-PCM is an audio recording format without digital compression. You can listen to the sound with the same quality as CD music by recording with this format.

What is bit rate?

Bit rate refers to the amount of data used to store each second of audio.

Generally, higher bit rates provide better sound quality, but require more storage space for the same length of audio.

What is the relationship between bit rate, sound quality, and storage size?

Generally, higher bit rates provide better sound quality, but require more storage space for the same length of audio, so you can store fewer songs on the player.

Lower bit rates enable you to store more songs, but at a lower sound quality.

For details about supported audio formats and bit rates, see  page 80.

Note

- If you import a song from a CD to your computer at a low bit rate, you cannot improve the song's sound quality by selecting a high bit rate when transferring the song from the computer to the player.

Storing Data Other than Audio Files

You can store computer data into the built-in flash memory of the player by transferring the data from your computer in Windows Explorer. If the player is connected to the computer, the built-in flash memory appears in Windows Explorer as [WALKMAN] or [Removable Disk.]

Notes

- Do not disconnect the player while “DATA ACCESS” appears on the player during data transfer. The data could be damaged.
- Do not format the built-in flash memory of the player in Windows Explorer. When you formatted the player in Windows Explorer accidentally, do it again on the player (🔧 page 49).
- Do not delete or change the name of the “MUSIC” folder, or transfer data other than audio data to the “MUSIC” folder. Otherwise, songs will not be played back on the player.

Upgrading the Player's Firmware

Player firmware updates can be made, enabling you to add new features to the player by installing the latest player's firmware to the player. For details about the latest firmware information and how to install it, visit the following web sites:

For customers in Europe: <http://support.sony-europe.com/DNA>

For customers in Latin America: <http://www.sony-latin.com/index.crp>

For customers in other countries/regions: <http://www.sony-asia.com/support>

For customers who purchased the overseas models: <http://www.sony.co.jp/overseas/support/>

- 1 Download the update program to your computer from the web sites.**
 - 2 Connect the player to your computer, and then start up the update program.**
 - 3 Follow the on-screen instructions to update the player's firmware.**
Firmware update is complete.
-

Troubleshooting

If the player does not function as expected, try the following steps to resolve the issue.

1 Find the symptoms of the issue in the following troubleshooting tables, and try any corrective actions listed.

2 Connect the player to your computer to charge the battery.

You may be able to resolve some issues by charging the battery.

3 Press the RESET button with a small pin, etc.

If you press the RESET button while operating the player, stored data and settings on the player may be deleted.

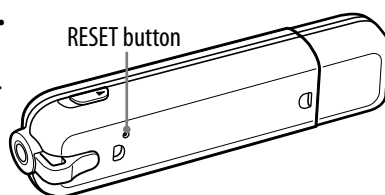

4 Check the information about the issue in the Help of the software.

5 Look for information about the issue on one of the support web sites.

For customers in Europe, visit: <http://support.sony-europe.com/DNA>

For customers in Latin America, visit: <http://www.sony-latin.com/index.crp>

For customers in other countries/regions, visit: <http://www.sony-asia.com/support>

For customers who purchased the overseas models, visit:

<http://www.sony.co.jp/overseas/support/>

6 If the approaches listed above fail to resolve the issue, consult your nearest Sony dealer.

Operation

Symptom	Cause/Remedy
There is no sound.	<ul style="list-style-type: none"> • The volume level is set to zero. <ul style="list-style-type: none"> → Turn the volume up (☞ page 9). • The headphone jack is not connected properly. <ul style="list-style-type: none"> → Connect the headphone jack properly (☞ page 10). • The headphone plug is dirty. <ul style="list-style-type: none"> → Clean the headphone plug with a soft dry cloth. • No song files are stored in the built-in flash memory. <ul style="list-style-type: none"> → If “NO DATA” appears, transfer audio file(s) from the computer.
Songs cannot be played.	<ul style="list-style-type: none"> • The battery is consumed. <ul style="list-style-type: none"> → Charge the battery fully (☞ page 13). → If the player does not react, even after charging the battery, press the RESET button to reset the player.

Operation (continued)

Symptom	Cause/Remedy
No data is played.	<ul style="list-style-type: none"> • The battery is consumed. <ul style="list-style-type: none"> → Charge the battery fully (☞ page 13). → If the player does not react, even after charging the battery, press the RESET button to reset the player (☞ page 62). • No data is stored on the player. <ul style="list-style-type: none"> → Transfer data from the computer to the player. • Transferred files are not in a playable format. <ul style="list-style-type: none"> → Songs may not be played back, depending on the file format. For details, see “Supported file format” of “Specifications” (☞ page 80). • Copyright protected files cannot be played. <ul style="list-style-type: none"> → Transfer necessary data to the computer, and delete unnecessary data. • After dragging and dropping in Windows Explorer, data hierarchy levels do not correspond to the player (☞ page 16).
Transferred data is not displayed in its list.	<ul style="list-style-type: none"> • The maximum number of files that can be displayed has been reached. The maximum number of files is 2,048 files, the maximum number of folders is 1,024 folders, and the total maximum number of files and folders directly under one folder is approximately 300. <ul style="list-style-type: none"> → Delete unnecessary data in Windows Explorer. • Data was placed in the wrong location by dragging and dropping. <ul style="list-style-type: none"> → Place the data under the “MUSIC” folder by dragging and dropping (☞ page 16). • Available capacity is insufficient. <ul style="list-style-type: none"> → Delete unnecessary data to increase free space on the player. • After dragging and dropping in Windows Explorer, data hierarchy levels do not correspond to the player (☞ page 16). • Transferred files are not in a playable format. <ul style="list-style-type: none"> → Songs may not be played back, depending on the file format. For details, see “Supported file format” of “Specifications” (☞ page 80). • If the folder/file name is 8 or less letters, and all lower case, the folder/file name appears in upper case letters on the player. <ul style="list-style-type: none"> → Rename the audio file name properly in Windows Explorer.
When “All Songs” is selected, songs may not appear.	<ul style="list-style-type: none"> • The folders or files are not under the “MUSIC” folder. <ul style="list-style-type: none"> → Place them under the “MUSIC” folder by dragging and dropping (☞ page 16).

Operation (continued)

Symptom	Cause/Remedy
Songs are played back within a limited playback range only, such as within one folder.	<ul style="list-style-type: none"> • The playback range is limited in the play mode (☞ page 22). → Change the play mode setting.
Data cannot be deleted on the player.	<ul style="list-style-type: none"> • You cannot delete songs on the player. → Delete them in Windows Explorer.
Noise is generated.	<ul style="list-style-type: none"> • A device emitting radio signals, such as a mobile phone is being used near the player. → When using a device such as a mobile phone, keep it away from the player. • Audio data from CDs, etc., is damaged. → Connect the player to the computer and delete any songs generating noise in Windows Explorer, and then import and transfer them to the player again. When importing audio data, close any other applications to avoid data damage.
Buttons do not work.	<ul style="list-style-type: none"> • The HOLD switch is set to the direction of the arrow (▷). → Slide the HOLD switch to the opposite direction of the arrow (☞ page 11). • Style-Up® Panel is not attached to the player properly. → Attach the Style-Up® Panel properly (☞ page 8). • The player contains moisture condensation. → Wait a few hours to let the player dry. • The remaining battery is low or insufficient. → Charge the battery by connecting to a running computer (☞ page 13). → If you charge the battery and nothing changes, press the RESET button to reset the player (☞ page 62). • While “DATA ACCESS” is being displayed, you cannot operate the player. Disconnect the USB connection, and then operate the player.
Playback does not stop.	<ul style="list-style-type: none"> • With this player, there is no difference between stopping and pausing. When you press the ► button, appears and playback pauses/stops.
The player does not work.	<ul style="list-style-type: none"> • The remaining battery is insufficient. → Charge the battery by connecting to a running computer (☞ page 13). → If you charge the battery and nothing changes, press the RESET button to reset the player (☞ page 62).

Operation (continued)

Symptom	Cause/Remedy
Transferred songs cannot be found.	<ul style="list-style-type: none"> • The built-in flash memory of the player was formatted in Windows Explorer. <ul style="list-style-type: none"> → Format the built-in flash memory on the player (🔗 page 49). • The player was disconnected from the computer while data was being transferred. <ul style="list-style-type: none"> → Transfer usable data back to your computer and format the built-in flash memory on the player (🔗 page 49). • After dragging and dropping in Windows Explorer, data hierarchy levels do not correspond to the player (🔗 page 16). • Transferred files are not in a playable format. <ul style="list-style-type: none"> → Songs may not be played back, depending on the file format. For details, see “Supported file format” of “Specifications” (🔗 page 80). • The folders or files are not under the “MUSIC” folder. <ul style="list-style-type: none"> → Place them under the “MUSIC” folder by dragging and dropping (🔗 page 16). • The audio files are beyond the 8th folder level. <ul style="list-style-type: none"> → Move the audio files beyond the 8th folder level to a lesser folder level in Windows Explorer (🔗 page 16). • If the folder/file name begins with “.” (dot), its name will not appear on the player. <ul style="list-style-type: none"> → Rename the data in Windows Explorer. • The maximum number of files that can be displayed has been reached. The maximum number of files is 2,048 files, the maximum number of folders is 1,024 folders, and the total maximum number of files and folders directly under one folder is approximately 300. <ul style="list-style-type: none"> → Delete unnecessary data in Windows Explorer.
The volume is not loud enough.	<ul style="list-style-type: none"> • “AVLS” is enabled. <ul style="list-style-type: none"> → Disable “AVLS” (🔗 page 37).
There is no sound from right channel of the headphones. Or right channel sound is heard from both sides of the headphones.	<ul style="list-style-type: none"> • The headphone jack is not fully inserted. <ul style="list-style-type: none"> → If the headphones are not connected correctly, sound will not be output properly. Connect the headphones into the jack until it clicks (🔗 page 10).
Playback has stopped suddenly.	<ul style="list-style-type: none"> • The remaining battery is insufficient. <ul style="list-style-type: none"> → Charge the battery by connecting to a running computer (🔗 page 13).
The player cannot format.	<ul style="list-style-type: none"> • The remaining battery is low or insufficient. <ul style="list-style-type: none"> → Charge the battery by connecting to a running computer (🔗 page 13).

Display

Symptom	Cause/Remedy
“□” appears for a title.	<ul style="list-style-type: none"> • Characters that cannot appear on the player are involved. <ul style="list-style-type: none"> → Rename the title with appropriate characters in Windows Explorer. • “File Disp Language” is not set for the title properly. <ul style="list-style-type: none"> → Set the correct language for the title using “File Disp Language” (🔧 page 23). • The data name is not one of the 8 setting languages for “File Disp Language” (🔧 page 23). <ul style="list-style-type: none"> → Rename the data with one of the 8 setting languages for “File Disp Language” in Windows Explorer.
A folder/file name in lower case letters appears in upper case.	<ul style="list-style-type: none"> • If the folder/file name is 8 or less letters, and all lower case, the folder/file name appears in upper case on the player. This is not malfunction.
A message appears.	<ul style="list-style-type: none"> • See the list of messages (🔧 page 70).

Power

Symptom	Cause/Remedy
Battery life is short.	<ul style="list-style-type: none"> • The operating temperature is below 5 °C (41 °F). <ul style="list-style-type: none"> → Battery life becomes shorter due to the battery characteristics. This is not malfunction. • Battery charging time is not enough. <ul style="list-style-type: none"> → Charge the battery until Full appears. → Charge the battery longer if the USB connection (USB Bus Powered) is set to “Low-Power 100mA” (🔧 page 43). • By adjusting the settings or managing the power supply properly, it is possible to save battery power and use the player for a longer time (🔧 page 58). • You have not used the player for a prolonged period. <ul style="list-style-type: none"> → The efficiency of the battery will be improved by repeatedly charging and discharging it. • When usable battery life becomes half the usual time, even after charging the battery fully, the battery should be replaced. <ul style="list-style-type: none"> → Consult your nearest Sony dealer.

Continued ↓

Power (continued)

Symptom	Cause/Remedy
The player cannot charge the battery.	<ul style="list-style-type: none"> • The player is not connected to a USB port on your computer properly. <ul style="list-style-type: none"> → Disconnect the player, and then reconnect it. • The battery is charged in an ambient temperature out of the range 5 °C (41 °F) to 35 °C (95 °F). <ul style="list-style-type: none"> → Charge the battery in an ambient temperature of 5 °C (41 °F) to 35 °C (95 °F). • Your computer is not on. <ul style="list-style-type: none"> → Turn on the computer. • Your computer enters Sleep or hibernate status. <ul style="list-style-type: none"> → Release the computer from Sleep or hibernate status.
The player turns off automatically.	<ul style="list-style-type: none"> • The player turns off if left in pause mode for a few seconds. <ul style="list-style-type: none"> → Press any button to turn the player on.
Charging completes very quickly.	<ul style="list-style-type: none"> • If the battery is already almost fully charged when charging begins, little time is needed to reach full charge.

Connection with the computer/"Auto Transfer" software

Symptom	Cause/Remedy
"Auto Transfer" software does not start up.	<ul style="list-style-type: none"> • If the "Auto Transfer" software does not start up by connecting the player to the computer, double-click [My Computer] - [WALKMAN] - or [Removable Disk] -  (AutoTransfer.exe). • You may have deleted the "Auto Transfer" software. <ul style="list-style-type: none"> → Download the "Auto Transfer" software from the support web sites (☞ page 18) and store it in the built-in flash memory of the player.
"USB CONNECT" does not appear on the player or the player is not recognized when the player is connected to the computer.	<ul style="list-style-type: none"> • The player's USB connection (USB Bus Powered) is set to "High-Power 500mA." <ul style="list-style-type: none"> → Set the "USB Bus Powered" to "Low-Power 100mA" (☞ page 43). • The player's USB connector is not connected to a USB port on your computer properly. <ul style="list-style-type: none"> → Disconnect the player, and then reconnect it. • A USB hub is being used. <ul style="list-style-type: none"> → Connecting the player via a USB hub may not work. Connect the player directly to a USB port on your computer. • Another application is running on the computer. <ul style="list-style-type: none"> → Disconnect the player, wait a few minutes, and reconnect it. If the problem persists, disconnect the player, restart the computer, and then reconnect the player. • The USB port on your computer may have a problem. Connect the player's USB connector to another USB port on your computer.

Connection with the computer/“Auto Transfer” software (continued)

Symptom	Cause/Remedy
Audio data cannot be transferred to the player from your computer.	<ul style="list-style-type: none"> • Transferring may be stopped due to noise such as static electricity, etc. This happens to protect data information. <ul style="list-style-type: none"> → Disconnect the player, then reconnect it. • The player’s USB connector is not connected to a USB port on your computer properly. Make sure that “DATA ACCESS” or “USB CONNECT” appears on the display. <ul style="list-style-type: none"> → Disconnect the player, and then reconnect it. • There is not enough free space in the built-in flash memory. <ul style="list-style-type: none"> → Transfer any unnecessary audio data back to your computer to increase free space on the player. • Songs with a limited playing period or playing count may not be transferred due to restrictions set by copyright holders. For details about the settings of each audio file, contact the distributor. • Abnormal data exists on the player. <ul style="list-style-type: none"> → Transfer usable data back to your computer and format the built-in flash memory on the player (🔧 page 49). • Audio files may be damaged. <ul style="list-style-type: none"> → Delete the audio files that cannot be transferred from your computer, then import them to the computer again. When importing/transferring the audio files, close any other applications to avoid file damage.
Only a small number of songs can be transferred to the player.	<ul style="list-style-type: none"> • There is not enough free space in the built-in flash memory. <ul style="list-style-type: none"> → Transfer any unnecessary audio data back to your computer to increase free space on the player. • Non-audio data is stored in the built-in flash memory. <ul style="list-style-type: none"> → Transfer the data back to your computer to increase free space on the player.
The player becomes unstable while it is connected to the computer.	<ul style="list-style-type: none"> • A USB hub is being used. <ul style="list-style-type: none"> → Connecting the player via a USB hub may not work. Connect the player directly to a USB port on your computer.

Continued ↓

FM Radio

Symptom	Cause/Remedy
You cannot hear the FM broadcast well.	<ul style="list-style-type: none"> The receiving frequency is not fully tuned in. <ul style="list-style-type: none"> → Select the frequency manually to improve reception (🔍 page 53).
Reception is weak and sound quality is poor.	<ul style="list-style-type: none"> The radio signal is weak. <ul style="list-style-type: none"> → Listen to the FM broadcast near a window since the signal may be weak inside buildings or vehicles. The headphone cord is not extended enough. <ul style="list-style-type: none"> → The headphone cord functions as an antenna. Extend the headphone cord as far as possible.
The FM broadcast is affected by interference.	<ul style="list-style-type: none"> A device emitting radio signals, such as a mobile phone is being used near the player. <ul style="list-style-type: none"> → When using a device such as a mobile phone, keep it away from the player.
An FM station cannot be preset.	<ul style="list-style-type: none"> The headphone cord is not extended enough. <ul style="list-style-type: none"> → The headphone cord functions as an antenna. Extend the headphone cord as far as possible.

Other

Symptom	Cause/Remedy
There is no beep sound when the player is operated.	<ul style="list-style-type: none"> “Beep” is set to “Beep OFF” <ul style="list-style-type: none"> → Set “Beep” to “Beep ON” (🔍 page 38).
The player gets warm.	<ul style="list-style-type: none"> The player may become warm during and just after battery charging. The player also may get warm when a large amount of data is transferred. This behavior is normal and not a cause for concern. Set the player aside for a while to allow it to cool down.
The date and time have been reset.	<ul style="list-style-type: none"> If you leave the player about three days with the battery used up, the date and time may be reset. <ul style="list-style-type: none"> → This is not a malfunction. Charge the battery until Full appears on the screen (🔍 page 13), and set the date and time again (🔍 page 39).
Noise is generated when you connect/disconnect headphones.	<ul style="list-style-type: none"> Do not connect/disconnect headphones while wearing them. Noise may result when you connect/disconnect headphones during music playback; however, this is not malfunction.

Messages

Follow the instructions below if a message appears in the display.

Message	Meaning	Remedy
ACCESS	This message appears after disconnecting the player from the computer, activating “File Disp Language” (🔗 page 23), “Reset All Settings” (🔗 page 48) or resetting the player (🔗 page 62).	This is not an error message. Wait until the message disappears.
AVLS (blinks)	The volume level exceeds the rated value while “AVLS” is enabled.	Turn the volume down or disable “AVLS” (🔗 page 37).
CANNOT PLAY	<ul style="list-style-type: none"> • The player cannot play certain files because of incompatible formats. • Transferring has been interrupted forcefully. • A copyright-protected file has been detected. 	<ul style="list-style-type: none"> • Check that songs are in a playable file format (🔗 page 80). • If the songs which cannot be played are unnecessary, erase them from the built-in flash memory. • Transfer the usable audio files back to your computer and format the built-in flash memory on the player (🔗 page 49).
DATA ACCESS	Accessing the built-in flash memory.	Please wait for access to complete. This message appears while the built-in flash memory is being accessed.
DRM ERROR	The player cannot play copyright-protected files.	If the songs which cannot be played are unnecessary, erase them from the built-in flash memory.
FILE ERROR	<ul style="list-style-type: none"> • The file cannot be read. • The file is not usable. • The player is disconnected from the computer while transferring audio files. 	Transfer the usable audio files back to your computer and format the built-in flash memory on the player (🔗 page 49).
FORMAT ERROR	The built-in flash memory was formatted on a computer.	Format the built-in flash memory on the player (🔗 page 49).

Message	Meaning	Remedy
HOLD	The player cannot be operated because the HOLD switch is set to the HOLD position.	To operate the player, slide the HOLD switch to the opposite position (☞ page 11).
LOW BATTERY	The battery is low.	You must charge the battery (☞ page 13).
MEMORY ERROR	There is a problem with the built-in flash memory.	Transfer the usable audio files back to your computer and format the built-in flash memory on the player (☞ page 49). If this message still appears, consult your nearest Sony dealer.
NO DATA	There are no audio files in the built-in flash memory.	<ul style="list-style-type: none"> • Transfer the usable audio files using the “Auto Transfer” software or Windows Explorer. • Place the audio files under the “MUSIC” folder by dragging and dropping (☞ page 16).
NO DATABASE	There is not enough space in the built-in flash memory.	Transfer the usable audio files back to your computer. If the problem persists, format the built-in flash memory on the player (☞ page 49).
NO ITEM	No song exists in the selected item.	Transfer the usable audio files using the “Auto Transfer” software or Windows Explorer.
PRESET FULL	30 broadcast stations are already preset.	You can preset up to 30 broadcast stations. If you want to preset more stations, delete unwanted stations first (☞ page 55), then preset the stations you want.
SYSTEM ERROR	There is a problem with the hardware.	Consult your nearest Sony dealer.
UPDATE ERROR	The player fails to update the firmware.	Follow the on-screen instructions on the computer and update again.
USB CONNECT	The player is connected to a computer.	This is not an error message. Do not disconnect the player until the USB connection completes.

Precautions

Notice for customers: the following information is only applicable to equipment sold in countries applying EU Directives

The manufacturer of this product is Sony Corporation, 1-7-1 Konan, Minato-ku, Tokyo, Japan. The Authorized Representative for EMC and product safety is Sony Deutschland GmbH, Hedelfinger Strasse 61, 70327 Stuttgart, Germany. For any service or guarantee matters please refer to the addresses given in separate service or guarantee documents.

Disposal of Old Electrical & Electronic Equipment (Applicable in the European Union and other European countries with separate collection systems)



This symbol on the product or on its packaging indicates that this product shall not be treated as household waste. Instead it shall be handed over to the applicable collection point for the recycling of electrical and electronic equipment. By ensuring this product is disposed of correctly, you will help prevent potential negative consequences for the environment and human health, which could otherwise be caused by inappropriate waste handling of this product. The recycling of materials will help to conserve natural resources. For more detailed information about recycling of this product, please contact your local Civic Office, your household waste disposal service or the shop where you purchased the product.

Applicable accessories: Headphones

Disposal of waste batteries (applicable in the European Union and other European countries with separate collection systems)



This symbol on the battery or on the packaging indicates that the battery provided with this product shall not be treated as household waste.

By ensuring these batteries are disposed of correctly, you will help prevent potentially negative consequences for the environment and human health which could otherwise be caused by inappropriate waste handling of the battery. The recycling of the materials will help to conserve natural resources.

In case of products that for safety, performance or data integrity reasons require a permanent connection with an incorporated battery, this battery should be replaced by qualified service staff only.

To ensure that the battery will be treated properly, hand over the product at end-of-life to the applicable collection point for the recycling of electrical and electronic equipment.

For all other batteries, please view the section on how to remove the battery from the product safely. Hand the battery over to the applicable collection point for the recycling of waste batteries.

For more detailed information about recycling of this product or battery, please contact your local Civic Office, your household waste disposal service or the shop where you purchased the product.

On safety

- Be sure not to short-circuit the terminals of the player with other metallic objects.
- Do not touch the rechargeable battery with bare hands if it is leaking. Since battery liquid may remain in the player, consult your nearest Sony dealer if the battery has leaked. If the liquid gets into your eyes, do not rub your eyes as it may lead to blindness. Wash out your eyes with clean water, and consult a doctor.
Also, if the liquid gets on to your body or clothes, wash it off immediately. If you do not, it may cause burns or injury. If you get burned or injured by the liquid from the battery, consult a doctor.
- Do not pour water or put any foreign object in the player. Doing so may cause fire or electric shock.
If this occurs, turn off the player immediately, disconnect the player, and consult your nearest Sony dealer or Sony Service Center.
- Do not put the player into fire.
- Do not take apart or remodel the player. Doing so can result in electric shock. Consult your nearest Sony dealer or Sony Service Center for exchange of rechargeable batteries, internal checks or repair.

Continued ↓

On installation

- Do not put any heavy object on top of the player or apply a strong shock to the player. It may cause a player to malfunction or damage.
- Never use the player where it will be subjected to extremes of light, temperature, moisture or vibration. The player may become discolored, distorted or damaged.
- Never leave the player exposed to high temperature, such as in a car parked in the sun or under direct sunlight.
- Do not leave the player in a place subject to excessive dust.
- Do not leave the player on an unstable surface or in an inclined position.
- If the player causes interference to radio or television reception, turn the player off and move it away from the radio or television.
- When using the player, remember to follow the precautions below in order to avoid warping the cabinet or causing the player to malfunction.
 - Make sure not to sit down with the player in your back pocket.
 - Make sure not to put the player into a bag with the headphones/earphones cord wrapped around it and then subject the bag to strong impact.



- Do not expose the player to water. The player is not waterproof. Remember to follow the precautions below.
 - Be careful not to drop the player into a sink or other container filled with water.
 - Do not use the player in humid locations or bad weather, such as in the rain or snow.
 - Do not get the player wet. If you touch the player with wet hands, or put the player in a damp article of clothing, the player may get wet and this may cause a malfunction of the player.



- When you unplug the headphones from the player, make sure to hold the headphone plug to unplug it. Pulling the headphone cord itself may cause damage to the headphone cord.

Continued ↓

On heat build-up

Heat may build up in the player while charging if it is used for an extended period of time.

On the headphones

Road safety

Avoid listening with your headphones in situations where hearing must not be impaired.

Preventing hearing damage

Avoid using the headphones at a high volume. Hearing experts advise against continuous, loud and extended play. If you experience a ringing in your ears, reduce the volume or discontinue use.

Do not turn the volume up high all at once, especially when using headphones. Turn up the volume gradually so that loud sound will not hurt your ears.

Caring for others

Keep the volume at a moderate level. This will allow you to hear outside sounds and to be considerate to people around you.

Warning

If there is lightning when you are using the player, take off the headphones immediately.

If you experience an allergic reaction to the supplied headphones, stop using them at once and contact a doctor.

On the use

- When using a strap (sold separately), be careful to avoid hooking it on objects you pass by. Furthermore be careful not to swing the player by the strap to avoid bumping people.
- Refrain from using the player according to the in-flight announcements during take off or landing in an aircraft.
- Note that condensation may form temporarily in cases such as when the player is moved quickly from a low-temperature environment to a high-temperature environment or used in a room that has a heater just turned on. Condensation creates a phenomenon where moisture in the air adheres to surfaces such as metal panels, etc., and then changes to liquid. If condensation forms in the player, leave it turned off until the condensation disappears. If you use the player with condensation present, a malfunction may result.

On the LCD

- Do not push the LCD screen strongly. Color spots may appear or the LCD panel may be damaged.
- If the player is used in a cold place, ghosting may occur. This does not indicate a failure.
- If the player is used in a cold or hot place, contrast may be affected.

On cleaning

- Clean the player's case with a soft cloth, such as cleaning cloth for eyeglasses.
- If the player's case becomes very dirty, clean it with a soft cloth slightly moistened with water or a mild detergent solution.
- Do not use any type of abrasive pad, scouring powder, or solvent, such as alcohol or benzene, as it may mar the finish of the case.
- Be careful not to let water get into the player from the opening near the connector.
- Clean the headphone plug periodically.

If you have any questions or problems concerning the player, please consult your nearest Sony dealer.

Continued ↓

Important Notice

- Copyright laws prohibit reproducing the software or the manual accompanying it in whole or in part, or renting the software without the permission of the copyright holder.
- In no event will SONY be liable for any financial damage, or loss of profits, including claims made by third parties, arising out of the use of the software supplied with this player.
- In the event a problem occurs with this software as a result of defective manufacturing, SONY will replace it. However, SONY bears no other responsibility.
- The software provided with this player cannot be used with equipment other than that to which it is so designated.
- Please note that, due to continued efforts to improve quality, the software specifications may be changed without notice.
- Operation of this player with software other than that provided is not covered by the warranty.
- The ability to display the languages on supplied software will depend on the installed OS on your computer. For better results, please ensure that the installed OS is compatible with the desired language you want to display.
 - We do not guarantee all the languages will be able to be displayed properly on the supplied software.
 - User-created characters and some special characters may not be displayed.
- The explanations in this manual assume that you are familiar with the basic operations of Windows.

For details about the use of your computer and operating system, please refer to the respective manuals.

Continued ↓

About sample data*¹

The player is pre-installed with sample data.

If you delete the sample data, you cannot restore it, and we will not supply any replacement data.

*¹ In some countries/regions some sample data is not installed.

- The recorded song is limited to private use only. Use of the song beyond this limit requires permission of the copyright holders.
- Sony is not responsible for incomplete recording/downloading or damaged data due to problems of the player or computer.
- Depending on the type of the text and characters, the text shown on the player may not be displayed properly on device. This is due to:
 - The capacity of the connected player.
 - The player is not functioning normally.
 - Content information is written in language or character that are not supported by the player.

About the customer support web sites

If you have any questions or issues with this product, or would like information on compatible items with this product, visit the following web sites.

For customers in Europe: <http://support.sony-europe.com/DNA>

For customers in Latin America: <http://www.sony-latin.com/index.crp>

For customers in other countries/regions: <http://www.sony-asia.com/support>

For customers who purchased the overseas models:

<http://www.sony.co.jp/overseas/support/>

About Copyrights

- “WALKMAN” and “WALKMAN” logo are registered trademarks of Sony Corporation.
- Microsoft, Windows, Windows Vista and Windows Media are trademarks or registered trademarks of Microsoft Corporation in the United States and/or other countries.
- Adobe and Adobe Reader are trademarks or registered trademarks of Adobe Systems Incorporated in the United States and/or other countries.
- MPEG Layer-3 audio coding technology and patents licensed from Fraunhofer IIS and Thomson.
- IBM and PC/AT are registered trademarks of International Business Machines Corporation.
- Macintosh is a trademark of Apple Inc.
- Pentium is a trademark or a registered trademark of Intel Corporation.
- “Style-Up” is a trademark or a registered trademark of Sony Ericsson Mobile Communications AB.
- US and foreign patents licensed from Dolby Laboratories.
- All other trademarks and registered trademarks are trademarks or registered trademarks of their respective holders. In this manual, TM and [®] marks are not specified.

This product is protected by certain intellectual property rights of Microsoft Corporation. Use or distribution of such technology outside of this product is prohibited without a license from Microsoft or an authorized Microsoft subsidiary.

Program ©2008 Sony Corporation
Documentation ©2008 Sony Corporation

Specifications

Supported file format

Music	
File format	MP3(MPEG-1 Layer3) file format, ASF file format, MP4 file format, Wave-Riff file format
File extension	MP3* ¹ (.mp3), WMA* ^{1,*2} (.wma), AAC-LC* ^{1,*2} (.mp4* ³ , .m4a, .3gp), Linear-PCM* ¹ (.wav)
Codec	MP3* ¹ Bit rate: 32 to 320 kbps (Supports variable bit rate (VBR)) Sampling frequency: 32, 44.1, 48 kHz
	WMA* ^{1,*2} Bit rate: 32 to 192 kbps (Supports variable bit rate (VBR)) Sampling frequency: 44.1 kHz
	AAC-LC* ^{1,*2} Bit rate: 16 to 320 kbps (Supports variable bit rate (VBR))* ⁴ Sampling frequency: 11.025, 12, 16, 22.05, 24, 32, 44.1, 48 kHz
	Linear-PCM* ¹ Bit rate: 1,411 kbps Sampling frequency: 44.1 kHz

*¹ File may not correspond to all encoders.

*² Copyright protected files cannot be played back.

*³ MP4 files with video are not playable.

*⁴ Non-standard bit rates or non-guaranteed bit rates are included depending on the sampling frequency.

Maximum recordable number of songs and time (Approx.)

The approximate times are based on a transferred 4-minute MP3 or Linear-PCM format song.

Other playable audio file format song numbers and times may differ from MP3 or Linear-PCM format.

Bit rate	NWD-E023F		NWD-E025F	
	Songs	Time	Songs	Time
48 kbps	685	45 hr. 40 min.	1,350	90 hr. 00 min.
64 kbps	510	34 hr. 00 min.	1,000	66 hr. 40 min.
128 kbps	255	17 hr. 00 min.	515	34 hr. 20 min.
256 kbps	125	8 hr. 20 min.	255	17 hr. 00 min.
320 kbps	100	6 hr. 40 min.	205	13 hr. 40 min.
1,411 kbps (Linear-PCM)	23	1 hr. 30 min.	47	3 hr. 00 min.

Continued ↓

Maximum recordable number of files and folders

Maximum number of files: 2,048 files

Maximum number of folders: 1,024 folders

Total maximum number of files and folders directly under one folder: Approx. 300

Capacity (User available capacity)*¹

NWD-E023F: 1 GB (Approx. 968 MB = 1,015,726,080 bytes)

NWD-E025F: 2 GB (Approx. 1.89 GB = 2,035,974,144 bytes)

*¹ Available storage capacity of the player may vary.

A portion of the memory is used for data management functions.

Output (headphones)

- Output
5 mW + 5 mW (16 Ω)
- Frequency response
20 to 20,000 Hz (when playing data file, single signal measurement)

FM radio

- Preset
30 presets
- FM Frequency range
87.5 to 108.0 MHz

IF (FM)

375 kHz

Antenna

Headphone cord antenna

Interface

Headphone: Stereo mini

Hi-Speed USB (USB 2.0 compliant)

Operating temperature

5 °C to 35 °C (41 °F to 95 °F)

Power source

- Built-in rechargeable lithium-ion battery
- USB power (from a computer through a USB connector of the player)

Charging time

USB-based charging

Approx. 60 minutes

Continued ↓

Battery life (continuous playback)

By setting as follows, a longer battery life can be expected.

The times below are approximated when “Power Save Mode” (☞ page 44) is set to “Save ON Super,” and “Sound” (☞ page 25), “Clear Stereo” (☞ page 30) and “Dynamic Normalizer” (☞ page 31) are deactivated.

The time below may differ depending on ambient temperature or the status of use.

NWD-E023F /NWD-E025F	
Status of the player	
Playback at MP3 128 kbps	Approximately 28 hours
Playback at WMA 128 kbps	Approximately 24 hours
Playback at AAC-LC 128 kbps	Approximately 28 hours
Playback at Linear-PCM 1,411 kbps	Approximately 25 hours
At receiving FM broadcasting	Approximately 10 hours

Display

3-line Color LCD

Dimension (w/h/d, projecting parts not included)

81.9 × 22.1 × 13.8 mm ($3\frac{1}{4} \times \frac{7}{8} \times \frac{9}{16}$ inches)

Dimension (w/h/d)

83.7 × 22.3 × 16.2 mm ($3\frac{3}{8} \times \frac{29}{32} \times \frac{21}{32}$ inches)

Mass

Approx. 28 g (Approx. 0.99 oz)

Continued ↓

System Requirements (for the player)

- Computer

IBM PC/AT or compatible computer preinstalled with the following Windows operating systems:

- Windows XP Home Edition (Service Pack 2 or later)
- Windows XP Professional (Service Pack 2 or later)
- Windows XP Media Center Edition 2004 (Service Pack 2 or later)
- Windows XP Media Center Edition 2005 (Service Pack 2 or later)
- Windows Vista Home Basic
- Windows Vista Home Premium
- Windows Vista Business
- Windows Vista Ultimate

Not supported by 64 bit version OS.

Not supported by OSs other than above.

- CPU: Pentium III 450 MHz or higher (For Windows Vista, Pentium III 800 MHz or higher)
- RAM: 128 MB or more (For Windows Vista, 512 MB or more)
- Hard Disk drive: 200 MB or more of available space (1.5 GB or more is recommended)
More space may be required, depending on the version of the operating system.
Additional space is required for storing music data.
- Display:
 - Screen Resolution: 800 × 600 pixels (or higher) (recommended 1,024 × 768 or higher)
 - Colors: High Color (16 bit) (or higher)
- CD-ROM drive (supporting Digital Music CD playback)
- Sound board
- USB port (Hi-Speed USB is recommended)
- Internet Explorer 6.0 or later needs to be installed.

We do not guarantee operation for all computers even if they meet the above System Requirements.

Not supported by the following environments:

- Personally constructed computers or operating systems
- An environment that is an upgrade of the original manufacturer-installed operating system
- Multi-boot environment
- Multi-monitor environment
- Macintosh

Design and specifications are subject to change without notice.

Index

Symbols

🎵	12
👤	12
📁	12
🎵1	25
🎵2	25
↺1 (Repeat 1 Song)	22
↺ (Repeat All)	22
↺📁 (Repeat Folder)	22
↺SHUF (Repeat Shuffle All)	22
↺📁 SHUF (Repeat Shuffle Folder)	22

A

AAC	59
AAC-LC	80
Adobe Reader	3
All Songs	19
Auto Transfer	17
AVLS	37

B

Battery	58, 82
Beep (Beep sound)	38
Bit rate	59, 80
Brightness	46

C

Clear Bass	25
Clear Stereo	30
Clock	33
Computer	83
Contrast	45

D

Date-Time	39, 41, 42
Date Disp Type	41
Display	12
Display Mode	32
Dynamic Normalizer	31

E

Equalizer	26, 28
Explorer	16, 60

F

Fast-forward	10
Fast-rewind	10
File Disp Language	23
Firmware	61
FM	6, 51
FM Auto Preset	52
Folder control mode	9, 22
Format	59
Format (Initialize)	49

H

Headphones	7, 75
HOLD switch	11
HOME button	9
HOME menu	6

I

Information	47
Initialize (Format)	49

L

Language	23
Linear-PCM	59, 80

M

Manual tuning	53
Manual Volume	34
Memory Capacity	81
Messages	70
Mono/Auto	57
MP3	59, 80

P

Playback	9, 12
PLAY MODE	22
Power	9, 58, 66
Power Save Mode	44
Preset tuning	53
Preset Volume	35, 36

R

Radio	51
Repeat.....	22
RESET (the player).....	62
Reset All Settings.....	48

S

Scan Sens	56
Search.....	6, 21
Serial Number	7, 47
Set Date-Time	39
Set the current time.....	39
Settings.....	6
Shuffle	22
Sleep status	9, 58
Song control mode	9
Sound	25
Sound preset.....	25
Sound quality	25, 26, 28
Sports Shuffle	20
Style-Up® Panel	8

T

Time Disp Type	42
Time information	33
Time setting.....	39
Troubleshooting.....	62
Tuner	51

U

Upgrading.....	61
USB Bus Powered (USB connection setting)	43

V

Volume.....	9, 31, 34
Volume Limit	37
Volume Mode.....	34
VOL +/- button	9

W

Windows Explorer.....	16, 60
WMA	59, 80