

# Radio Cassette-Corder

## Operating instructions



©2003 Sony Corporation Printed in Malaysia

Printed using VOC (Volatile Organic Compound)-free vegetable oil based ink.

http://www.sony.net/

"WALKMAN" is a registered trademark of Sony Corporation to represent Headphone Stereo products.

WALKMAN is a trademark of Sony Corporation.

The validity of the CE marking is restricted to only those countries where it is legally enforced, mainly in the countries EEA (European Economic Area).

## WARNING

To prevent fire or shock hazard, do not expose the unit to rain or moisture.

Do not install the appliance in a confined space, such as a bookcase or built-in cabinet.

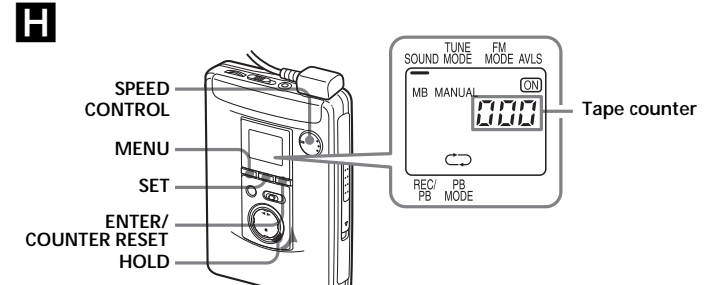
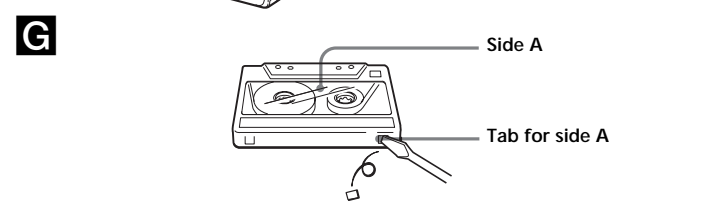
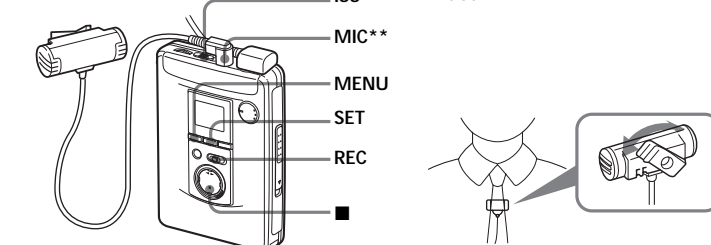
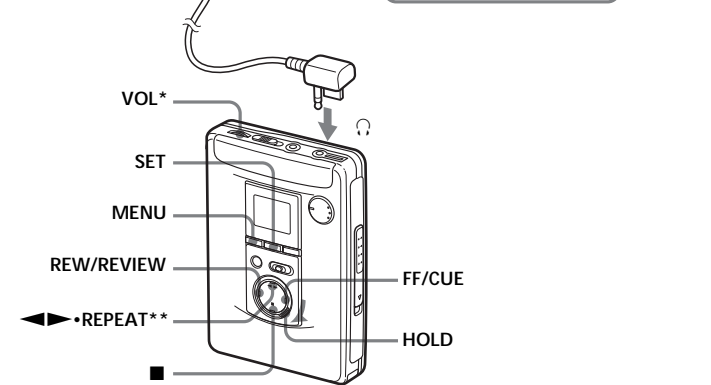
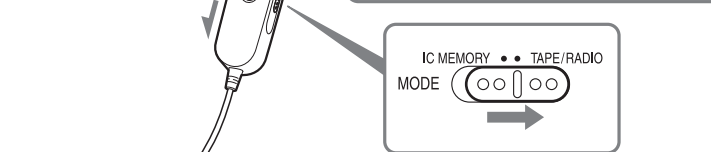
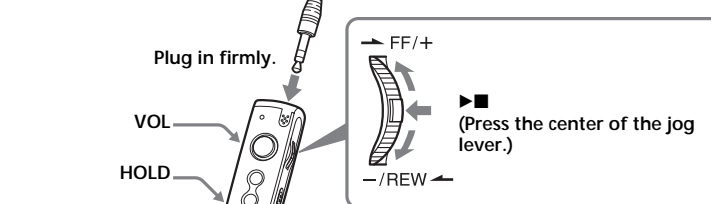
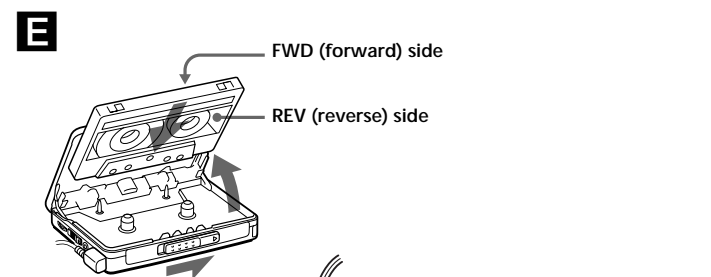
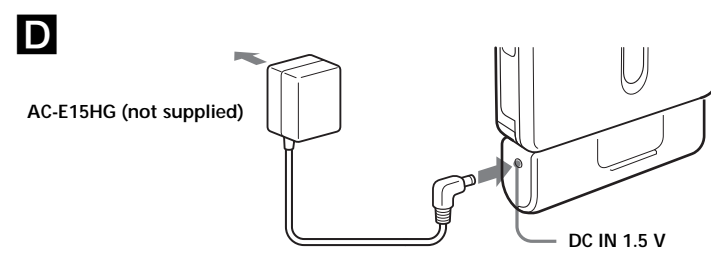
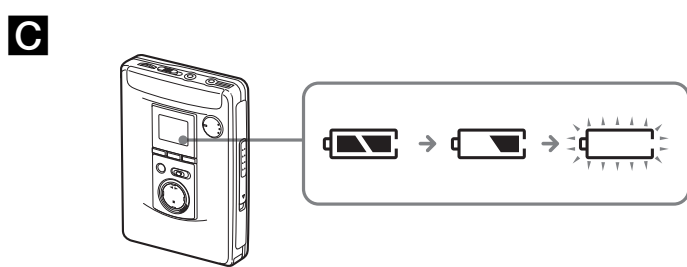
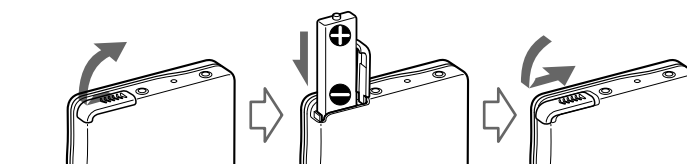
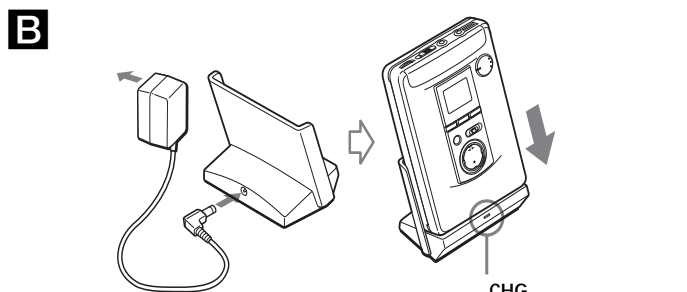
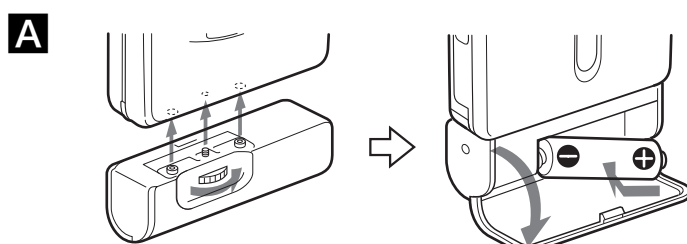

**Note**  
Tapes recorded with setting to "2x" cannot be played properly on a cassette player/tape recorder without this function.

- To prevent fire, do not cover the ventilation of the apparatus with newspapers, table-cloths, curtains, etc. And don't place lighted candles on the apparatus.
- To prevent fire or shock hazard, do not place objects filled with liquids, such as vases, on the apparatus.
- Certain countries may regulate disposal of the battery used to power this product. Please consult with your local authority.

## Preparations

Prepare a dry battery (not supplied) or the rechargeable battery (supplied).

### Dry Battery A

Attach the supplied battery case, and then insert one R6 (size AA) battery with correct polarity.

### Note

For maximum performance we recommend that you use a Sony alkaline battery.

### Rechargeable Battery B

Charge the rechargeable battery before using it for the first time.

- Insert the supplied rechargeable battery NH-14WM(A) into the rechargeable battery compartment with correct polarity.
- Connect the supplied AC power adaptor to the charging stand, plug in the AC power adaptor to the house current (mains).
- Place the main unit on the charging stand. The CHG lamp will light up. Full charging takes about 6 hours. The CHG lamp will go off when the battery is fully charged.

### Note

- Do not use the unit while charging. Remove the unit from the charging stand when using it.
- If you operate the unit while charging, the battery will not be charged.
- If you operate the unit while charging, it may cause malfunction.
- Do not place the unit on the charging stand without the rechargeable battery. Otherwise, it may cause malfunction.

## When to replace/charge the battery C

Replace or charge the battery when " " flashes in the display.

Battery life* (Approx. hours)	
Sony alkaline LR6 (SG)**	
Tape playback	44
Radio reception	56
MIC recording	15
Radio recording	12

Rechargeable battery NH-14WM (A)	
Tape playback	26
Radio reception	34
MIC recording	9
Radio recording	7

Sony alkaline LR6 (SG)** and Rechargeable NH-14WM (A)	
Tape playback	70
Radio reception	90
MIC recording	24
Radio recording	19

\* Measured value by the standard of JEITA (Japan Electronics and Information Technology Industries Association). (Using a Sony HF series cassette tape)  
\*\* When using a Sony LR6(SG) "STAMINA" alkaline dry battery (produced in Japan).

### Notes

- The battery life may be shorter depending on the operating condition, the surrounding temperature and battery type.
- The AVLS setting (see "Using the Menu") will be cancelled when you replace the battery.

### House Current D

You must purchase an AC power adaptor AC-E15HG to operate this unit using house current. Remove the rechargeable battery if inserted. Attach the battery case and connect the AC power adaptor AC-E15HG (not supplied) to the DC IN 1.5V jack of the battery case and to the wall outlet. Do not use any other AC power adaptor. Specifications for AC-E15HG vary for each area. Check your local voltage and the polarity of the plug before purchasing.

This radio cassette-corder is supplied with a special IC memory function remote control. When playing a tape, recording or listening to the radio, make sure that the MODE switch is set to TAPE/RADIO.

## Playing a Tape E

- Insert a cassette and if the HOLD function is on, slide the HOLD switch in the opposite direction of the arrow to unlock the controls.
- Press MENU repeatedly to set " " (the cursor) in the display to REC/PB. Then press SET to select "2x" or none (normal speed) which is the same position as that used for recording. To playback commercially available music tape, etc., select normal (no indication).
- Press ◀•REPEAT on the main unit and adjust the volume with VOL. (On the remote control, press ▶ (play) ■(stop).)

When adjusting the volume on the remote control  
Set the VOL control on the main unit to around 6.

When adjusting the volume on the main unit  
Set the VOL control on the remote control at maximum.

### Operation on the remote control

To	Jog lever
Switch playback to the other side	Press ▶■ for 2 seconds or more during playback.
Stop playback	Press ▶■ once during playback.
Fast forward*	Move toward FF/+ during stop.
Rewind*	Move toward -/REW during stop.

Play the other side from the beginning (Skip Reverse function)  
Move and hold toward FF/+ for 2 seconds or more during stop.

Play the same side from the beginning (Rewind Auto Play function)  
Move and hold toward -/REW for 2 seconds or more during stop.

### Operation on the main unit

To	Press
Switch playback to the other side	◀•REPEAT during playback
Stop playback	■ (stop)
Fast forward	FF/CUE during stop
Rewind	REW/REVIEW during stop

Play the other side from the beginning (Skip Reverse function)  
Press and hold FF/CUE for 2 seconds or more during stop.

Play the same side from the beginning (Rewind Auto Play function)  
Press and hold REW/REVIEW for 2 seconds or more during stop.

\* Press ◀•REPEAT (on the remote control, press the jog lever) during fast forward or rewind to start playback.

### Other Tape Operations

**To play the next track/succeeding 9 tracks from the beginning (AMS\*)**  
On the remote control: Move the jog lever toward FF/+ once or repeatedly during playback.  
On the main unit: Press FF/CUE once or repeatedly during playback.

**To play the current track/previous 8 tracks from the beginning (AMS\*)**

On the remote control: Move the jog lever toward -/REW once or repeatedly during playback.  
On the main unit: Press REW/REVIEW once or repeatedly during playback.

\* Automatic Music Sensor

### Search forward/backward during playback (CUE/REVIEW)

On the remote control: Move and hold the jog lever toward FF/+ or -/REW during playback and release it at the point you want.  
On the main unit: Press and hold FF/CUE or REW/REVIEW during playback and release it at the point you want.

### A-B Repeat

A-B Repeat plays back repeatedly any portion of the tape you specified. Specify by tagging the beginning (point A) and the end (point B) of the portion during playback.

### On the main unit

- Press ◀•REPEAT for 2 seconds or more during playback to tag point A. "A-" will flash in the display of the main unit.
- Press ◀•REPEAT again to tag point B. "A-B" will flash and the tape will move rapidly to point A. Then "REP" appears in the display and the specified portion is played repeatedly.

### Operation on the remote control

- Press ▶■ twice quickly during playback to tag point A.
- Press ▶■ once more to tag point B. The tape will be rewound to point A. Then the specified portion is played repeatedly.

### To stop the A-B Repeat playback

Press ◀•REPEAT on the main unit. On the remote control, press ▶■.

### To reset A-B Repeat

When you want to change a specific portion, stop the A-B Repeat playback and tag point A and point B again.

### Notes

- You cannot specify a repeat portion that includes both sides of the tape.
- You cannot specify a repeat portion shorter than 2 seconds.
- After repeated operation, the actual portion that is played back may shift somewhat from the exact portion specified with the tags due to tape slack.
- A-B Repeat stops automatically after repeating 50 times.
- Do not use the A-B Repeat function with tapes longer than 90 minutes. If you do, the tape may be damaged.

## Recording F

You can record radio programs from the built-in radio, or record with the supplied microphone. In either case, use a new or fully charged battery.

### Note

If the record-protect tab is broken, you cannot record on that side.

### To stop recording

Press ■ (on the remote control, press ▶■ to stop recording).

### To reduce noise while recording AM programs

Set the ISS (Interference Suppress Switch) to the position that reduces noise the most.

### To monitor the recording sound

You can monitor the recording sound through headphones/earphones. Adjust monitoring level using VOL.

### Note

- You may hear some noise in the monitor sound in the RV, MB, or GRV mode (see "Using the Menu"), but this does not affect recording.
- Notes on recording
- The recording level is fixed.
- Sound emphasis (RV, MB, or GRV) and AVLS settings do not affect recording.
- Actual recording will start about 2 seconds (3 seconds when "2x" is selected for recording time) after you slide the REC button. Slide the REC button about 2 seconds (3 seconds when "2x" is selected for recording time) before the moment you want to start recording, or you will miss the beginning of your recording.

Normal (no indication) (4.8cm/s): for optimum sound. Recommended for normal recordings. 2x (2.4cm/s): for double recording time (for example, 120 minutes using both sides of a 60-minute cassette). Suitable for recording conferences, dictations, etc. Not recommended for recording music.

### To record with the microphone

Connect the supplied microphone to the MIC (PLUG IN POWER) jack. You can attach the microphone to your clothes as illustrated. F To record from the radio Tune in to the station you want to record (see "Listening to the Radio").

### To prevent a tape from being accidentally recorded over G

Break off the tabs from side A and/or B. To reuse the tape for recording, cover the tab hole with adhesive tape.

## Using the Menu H

### Adjusting the Playback Modes

Press MENU repeatedly to set the cursor in the display to PB MODE. Then press SET to select the desired mode.

To play	Select
both sides repeatedly	↔
both sides once	↶
from the FWD side	↷

### Emphasizing Sound

- Press MENU repeatedly to set the cursor in the display to SOUND.
- Press SET repeatedly to select the sound emphasis of your choice.

The indications change as follows:

- RV : Sound Revitalizer Emphasizes treble sound.
- MB : Mega Bass Emphasizes bass sound (moderate effect).
- GRV : Groove Emphasizes bass sound (strong effect).
- no message : normal (no effect)

### Note

If the sound is distorted with the mode "GRV", turn down the volume of the main unit or select other modes.

## Protecting Your Hearing — AVLS (Automatic Volume Limiter System)

The maximum volume is kept down to protect your ears. Press MENU repeatedly in the playback, stop or radio mode to set the cursor in the display to AVLS. Then press SET to show "AVLS".

### To cancel the AVLS function

Press SET so that "AVLS" disappears from the display.

## Using Other Functions I

### Adjusting the Tape Playback Speed

You can adjust the playback speed using SPEED CONTROL. Turn SPEED CONTROL to: - (slow) to play back at a slower speed. Center position to play back at normal speed. + (fast) to play back at a faster speed.

### Using the Menu H

The SPEED CONTROL works in the playback mode only. Recording will be made independent of this control.

### Locking the Controls — HOLD Function

Slide the HOLD switch in the direction of the arrow to lock the controls of the main unit (except SPEED CONTROL) or the remote control.

### Using the Tape Counter

The tape counter is displayed on the main unit during playback, recording, fast forward, rewind, CUE, REVIEW and stop (except when the radio is turned on). The number will increase when playing back the FWD side, and decrease when playing back the REV side. To reset the counter to "000", press ENTER/COUNTER RESET.

### Notes

- The tape counter may show some deviation.
- The tape counter will not be displayed when the cassette compartment is empty.

(turn over)



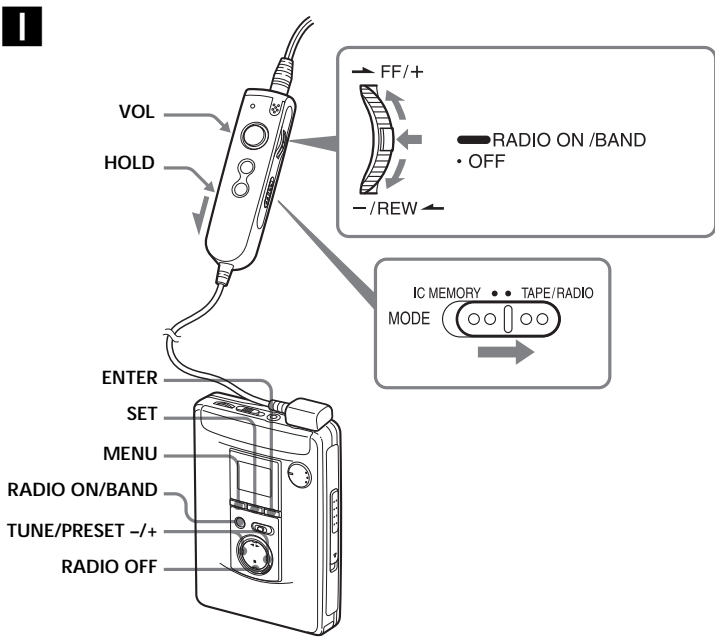

## Listening to the Radio **I**

- 1 Press RADIO ON/BAND to turn on the radio.
- 2 Press RADIO ON/BAND repeatedly to select AM or FM.

- 3 Press MENU on the main unit repeatedly and set the cursor in the display to TUNE MODE.

- 4 For manual tuning
  - ① Press SET to choose MANUAL.
  - ② Press TUNE/PRESET + or - repeatedly to tune in to the desired station. Hold down TUNE/PRESET + or - for a few seconds to scan for stations.

### For preset tuning

- ① Press SET to choose PRESET.
- ② Press TUNE/PRESET + or - repeatedly to recall the desired preset station. To use preset tuning, preset stations first (see "Presetting Radio Stations").

### To turn off the radio

Press RADIO OFF.

### To improve the broadcast reception

- For AM: Reorient the unit itself. When listening to an AM program, keep the remote control away from the main unit, otherwise, noise may be heard.
- For FM: Extend the remote control cord (antenna). If the reception is still not good, press MENU repeatedly to set the cursor in the display to FM MODE. Then press SET to choose from "MONO" (monaural), "LOCAL" or none (stereo) for best reception.

### To operate from the remote control

To turn on the radio, press RADIO ON/BAND•OFF (the center of the jog lever) for more than 1 second (while the tape is in stop mode only). To select the band, press RADIO ON/BAND•OFF for more than 1 second while the radio is on. To tune in or recall a preset station, move toward FF/+ or -/REW. To turn off the radio, press RADIO ON/BAND•OFF.

## Presetting Radio Stations **I**

You can preset up to 30 stations—20 for FM and 10 for AM (for the JPN area\*, up to 16 stations—8 for FM and 8 for AM). \* Only if available. See "Receiving Stations Outside Your Country/Region".

### Presetting Automatically Scanned Stations

- 1 Press RADIO ON/BAND to turn on the radio.
- 2 Press RADIO ON/BAND repeatedly to select AM or FM.
- 3 Press and hold ENTER for more than 3 seconds. Preset number 1 will flash in the display and the main unit starts scanning the stations from the lower frequencies and stops for about 5 seconds when a station is received.

- 4 If you wish to preset the currently received station, press ENTER while the preset number is flashing. The received station is preset on preset number 1 and the unit starts scanning for the next receivable station.

- 5 Repeat step 4 until all receivable stations are preset.

### To stop scanning

Press RADIO OFF. The radio is turned off at the same time.

### Notes

- If stations are already stored, the newly preset stations replace the old ones when the above procedure is completed.
- If stations cannot be preset automatically, preset them manually.

### Presetting Stations Manually

- 1 Press RADIO ON/BAND to turn on the radio.
- 2 Press RADIO ON/BAND repeatedly to select AM or FM.
- 3 Press ENTER.

The frequency digits will flash in the display.

- 4 While the frequency digits are flashing, tune in to a station you wish to store using TUNE/PRESET + or - and press ENTER.

The preset number will flash in the display.

- 5 While the preset number is flashing, select the preset number you want using TUNE/PRESET + or - and press ENTER.

### Notes

- If you cannot complete step 4 or 5 while the indicators are flashing, repeat from step 3.
- If a station is already stored, the new station replaces the old one.

### Playing the Preset Radio Stations

- 1 Press RADIO ON/BAND to turn on the radio.
- 2 Press RADIO ON/BAND repeatedly to select AM or FM.
- 3 Press MENU repeatedly to set the cursor in the display to TUNE MODE. Then press SET to display "PRESET".
- 4 Press TUNE/PRESET + or -.

### To cancel a stored station

- 1 Follow the procedure above and in step 4, select the preset number you want to cancel and then press ENTER. The frequency digits will flash in the display.
- 2 Press and hold TUNE/PRESET + or -. The frequency digit starts running up or down. Keep holding down the button until "...-" is displayed.
- 3 Press ENTER while "...-" is flashing. A preset number will flash in the display.
- 4 Press ENTER to cancel the stored station.

### Scanning the Preset Radio Stations — DAPS (Digital Auto Preset Scanning)

- 1 Press RADIO ON/BAND to turn on the radio.
- 2 Press RADIO ON/BAND repeatedly to select AM or FM.
- 3 Press and hold RADIO ON/BAND for 2 seconds or more.

The preset stations of the selected band will be played for about 5 seconds each. (During DAPS the indicators in the display flash.)

- 4 Press RADIO ON/BAND again to select the station while the desired preset station is being played.

### Notes

- If there are no stations stored, the DAPS function does not work.
- Until a station is selected in step 4, the DAPS function turned on in step 3 will continue.

## Receiving Stations Outside Your Country/Region (Excluding European, Saudi Arabian, and Chinese models)

- 1 Press RADIO ON/BAND to turn on the radio.
- 2 Press ENTER. The frequency digits will flash in the display.
- 3 Press and hold RADIO ON/BAND until "Eur", "USA" or "JPN" flashes.
- 4 Press RADIO ON/BAND repeatedly to select "Eur", "USA" or "JPN" and press ENTER.
- 5 Tune in to and store stations as necessary following the procedure of "Listening to the Radio" and "Presetting Radio Stations".

### Area indication and frequency range

Area*	Frequency range	
	FM (MHz)	AM (kHz)
Eur	87.5 - 108	531 - 1 602
USA	87.5 - 108	530 - 1 710
JPN	76.0 - 90.0	531 - 1 710

\* Eur :European and other countries/regions  
USA :USA, Canada, and Central and South America  
JPN: Japan

## Using the IC memory on the Remote Control **J**

The supplied language learning remote control has an IC memory function. Its maximum memory capacity is 480 seconds (8 minutes): 6 minutes for recording in IC memory from tape or radio, 1 minute for phrase repeat from tape, and 1 minute for voice recording.

### Note

When using the IC memory function on the remote control, slide the HOLD switch of the main unit in the direction of the arrow to lock the controls. This is to prevent accidentally pressing the button on the main unit and activating other functions.

### Recording in IC Memory from Tape or Radio

You can record the sound from tape or radio in the IC memory. The recorded sound is stored in a file that is created on the IC memory for each recording. You can record up to 6 minutes (or up to 30 files).

- 1 Start playback from a tape or the radio.
- 2 Set the VOL control on the main unit to around 6.
- 3 Press COMPARE/STORE to start recording. The OPR indicator shows the remaining IC memory space as follows:  
**Lights in red:** more than 1 minute  
**Flashes every second:** 1 minute or less  
**Flashes every 0.5 seconds:** 30 seconds or less  
**Flashes 4 times every 0.2 seconds, and a beep sound is heard:** full
- 4 Press the jog lever to stop recording. One file is created in the IC memory and the sound is stored in the file. If the memory becomes full during recording, the recording stops automatically.

### Note

The recording function records in IC memory regardless of the main unit functions if you accidentally press COMPARE/STORE.

### Playing Files Recorded in IC Memory

- 1 Slide the MODE switch to IC MEMORY.
- 2 Press the jog lever. The last file recorded or the file you stopped last time will be played back. The OPR indicator lights in green during playback. Playback will automatically stop after the last file recorded was played back.

### To stop the playback before the last file

Press the jog lever again. When you press the jog lever next time, the playback will start from the beginning of the file you stopped.

### Other operations

To	Move the jog lever
Skip to the beginning of the current/previous files	Toward -/REW once or repeatedly
Succeeding files	If you move the jog lever toward FF/+ at the last file, 2 beeps are heard and playback starts from the beginning of the oldest file.

To	Move the jog lever
Go back to the beginning of the current/previous files	Toward -/REW once (to the beginning of the current file) or repeatedly (to the beginning of the the previous file) If you move the jog lever toward -/REW at the oldest file, a long beep sound is heard and playback starts from the beginning of the oldest file.
CUE	Move and hold toward FF/+ during playback When you move and hold the jog lever toward FF/+ at the last file, a beep sound is heard and playback stops.
REVIEW	Move and hold toward -/REW during playback When you move and hold the jog lever toward -/REW at the oldest file, a long beep sound is heard and playback starts from the beginning of the oldest file.

### Erasing All Files from IC Memory

Press SET and REPEAT at the same time (ALL ERASE) and hold both buttons for 5 seconds. All IC memory files will be erased and a beep sound is heard.

### Note

You cannot erase only 1 file.

## Using the Language Learning Repeat Function **K**

### Note

When using the language learning repeat function, slide the HOLD switch of the main unit in the direction of the arrow to lock the controls. This is to prevent accidentally pressing the button on the main unit and activating other functions.

### Listening to a Desired Portion Repeatedly (Phrase Repeat)

When you want to listen repeatedly to a particular phrase on the tape or among files recorded in IC memory, set the starting point (A) and the ending point (B) of the phrase.

### To set a desired portion on IC memory (phrase repeat setting)

- 1 Slide the MODE switch to TAPE/RADIO or IC MEMORY.
- 2 Play back a recorded tape sound or a file recorded in IC memory.

- 3 During playback, press SET to tag the starting point (A). The OPR indicator flashes in orange.  
The OPR indicator shows the remaining time as follows:  
**Lights in orange:** more than 10 seconds  
**Flashes every second:** 10 seconds or less  
**Flashes every 0.5 seconds:** 5 seconds or less
- 4 During playback, press REPEAT to tag the ending point (B).  
The desired portion (point A-B) is set and the phrase between A and B will be played back repeatedly.  
The OPR indicator flashes in green.  
During playback, the tape is in the pause mode.

### Note

For phrase repeat setting from a tape: if you do not set point B, the ending point is automatically set to the end of 1 minute.  
For phrase repeat setting from files recorded in IC memory: if you do not set point B, the ending point is automatically set to the end of the last recorded file.

### To reset the point

During playback, press SET at the point you want to reset point A, press REPEAT at the point you want to reset point B. The OPR indicator flashes in green.

### To stop phrase repetition

Press the jog lever. The settings you made (points A and B) are erased, and the tape or IC memory playback starts from the point you stopped (resume function).

### Comparing Your Recorded Voice with Particular Phrase (Repeat & Compare Function)

You can listen to a particular phrase and then your recorded voice, one after the other repeatedly.

- 1 Set the desired phrase (see "Listening to a desired portion repeatedly"). The phrase plays repeatedly.
- 2 Press COMPARE/STORE and start voice recording using VOICE (the built-in microphone). The OPR indicator lights in orange during recording. Your voice is recorded. The maximum recording time is 1 minute.

The OPR indicator shows the remaining time as follows:  
**Lights in orange:** more than 10 seconds.  
**Flashes every second:** 10 seconds or less  
**Flashes every 0.5 seconds:** 5 seconds or less

When you want to improve the recorded result, repeat step 2 after step 3.

- 3 Press REPEAT.  
Your recorded voice and the preset phrase play repeatedly in turn. The OPR indicator flashes in green during playback. During playback, the tape is in the pause mode.

### To stop Repeat & Compare function

Press the jog lever. The preset phrase and your recorded voice will be erased, and the tape or IC memory playback starts from the point you stopped (resume function).

## Precautions

### On charging

- The supplied charging stand can be used only with this unit. No other model can be charged using this stand.
- Remove the AC power adaptor from the wall outlet as soon as possible after the rechargeable battery has been charged. Overcharging may damage the rechargeable battery.
- The charging stand and the rechargeable battery may become warm during charging, but this is not a problem.
- Do not tear off the film on the rechargeable battery.
- Use only the supplied charging stand to charge the supplied rechargeable battery.
- Be sure not to short-circuit the battery. When you carry it with you, use the supplied carrying case. If you are not using the case, do not carry the battery with other metallic objects such as keys, rings in your pocket.
- If the rechargeable battery is new or has not been used for a long time, it may not be charged completely until you use it several times.

### On batteries

- Do not charge a dry battery.
- Do not carry the dry or rechargeable batteries with coins or other metallic objects. It can generate heat if the positive and negative terminals of the batteries are accidentally contacted by a metallic object.
- When you do not use the main unit for a long time, remove the battery to avoid any damage caused by battery leakage and subsequent corrosion.

### On AC power adaptor

- Use only the supplied AC power adaptor (for charging stand) and recommended AC power adaptor (for battery case). Do not use any other AC power adaptor.

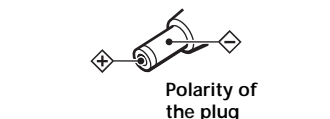

## Troubleshooting

The sound drops out or comes with excessive noise.

- Clean the headphones/earphones and remote control plugs.

The unit does not operate at all.

- Charge the battery or replace the dry battery with a new one.
- HOLD is activated. Deactivate HOLD.

Tape operation is not possible.

- Insert a cassette tape.

The volume cannot be turned up.

- If AVLS is on, turn it off.

A beep sounds and recording is not possible when REC is slid.

- If the tab of the tape is broken off, cover the tab hole with adhesive tape.

The display and the operations are not normal.

- Remove the power sources for 15 seconds or more, and then set them again.

The radio and playback operates but recording is not possible.

- This condition may occur when the battery becomes weak. Replace or charge the battery.

## Specifications

### Radio section

Frequency range	FM: 76.0 - 90.0 MHz (Japan) 87.5 - 108 MHz (other countries/regions)	AM: 531 - 1 710 kHz (Japan) 530 - 1 710 kHz (North, Central, and South America) 531 - 1 602 kHz (other countries/regions)
-----------------	---	---

### Tape section

Frequency response  
Playback: 40 - 15 000 Hz  
Recording/playback: 100 - 8 000 Hz

Output  
Headphones (⌚) jack  
Load impedance 8 - 300 Ω

Input  
Microphone (MIC) jack

### General

Power requirements  
1.5 V  
Rechargeable battery  
One R6 (size AA) battery

Dimensions (w/h/d)  
Approx. 77.1 × 108.0 × 22.5 mm  
(3¼ × 4¼ × ¾ inches) excl. projecting parts and controls

### Mass

Approx. 152 g (5.4 oz) (main unit only)

Supplied accessories  
AC power adaptor (1)  
Battery case (1)  
Stereo headphones or earphones with remote control (1)  
Charging stand (1)  
Rechargeable battery (NH-14WM(A), 1.2 V, 1 350 mAh (min), Ni-MH (1))  
Rechargeable battery carrying case (1)  
Carrying pouch (1)  
Stereo microphone (1)

Design and specifications are subject to change without notice.

