

SONY[®]

3-866-556-11 (1)

IC Recorder

Operating Instructions

V O I C E F I L E

ICD-35

©1999 by Sony Corporation

For the customers in the United States

Owner's Record

The model number is located at the rear and the serial number is located inside the battery compartment. Record the serial number in the space provided below. Refer to these numbers whenever you call upon your Sony dealer regarding this product.

Model No. ICD-35

Serial No. _____

INFORMATION

This equipment has been tested and found to comply with the limits for a Class B digital device, pursuant to Part 15 of the FCC Rules. These limits are designed to provide reasonable protection against harmful interference in a residential installation. This equipment generates, uses, and can radiate radio frequency energy and, if not installed and used in accordance with the instructions, may cause harmful interference to radio communications.

However, there is no guarantee that interference will not occur in a particular installation. If this equipment does cause harmful interference to radio or television reception, which can be determined by turning the equipment off and on, the user is encouraged to try to correct the interference by one or more of the following measures:

- Reorient or relocate the receiving antenna.
- Increase the separation between the equipment and receiver.
- Connect the equipment into an outlet on a circuit different from that to which the receiver is connected.
- Consult the dealer or an experienced radio/TV technician for help.

This device complies with Part 15 of the FCC Rules. Operation is subject to the following two conditions: (1) This device may not cause harmful interference, and (2) this device must accept any interference received, including interference that may cause undesired operation.

You are cautioned that any changes or modifications not expressly approved in this manual could void your authority to operate this equipment.

Table of Contents

What is the ICD-35 IC recorder?	4
Features	5

Getting Started

Step 1: Installing the Battery	6
Step 2: Setting the Clock	8

Basic Operations

Recording Messages	10
Playing Back Messages	13
Erasing Messages	16

Advanced Operations

Moving Messages to a Different File — Move Function	18
Adjusting the Playback Speed	20
Adding a Recording to a Previously Recorded Message	21
Playing Back a Message at a Desired Time with an Alarm	22
Preventing Accidental Operation — HOLD function	26

Menu Settings

Selecting the Recording Mode	27
Turning off the Beep Sound	28
Selecting the Microphone Sensitivity	30
Playing Back All Messages in a File Continuously	31
Selecting the Illumination Mode of LCD Back Light	32

Additional Information

Precautions	33
Troubleshooting	34
Specifications	35
Index to Parts and Controls	36
Menu map	38
Index	Back cover

What is the ICD-35 IC recorder?

The ICD-35 IC recorder enables you to record and play back oral messages in the built-in IC memory.

● Recording

When a new message is recorded, it is automatically added after the last recorded messages.

Unlike with tape recorders, you do not need to worry about recording over previously recorded messages by mistake.

Since you do not need to search for the end of the last recording, you can start recording quickly whenever you wish.

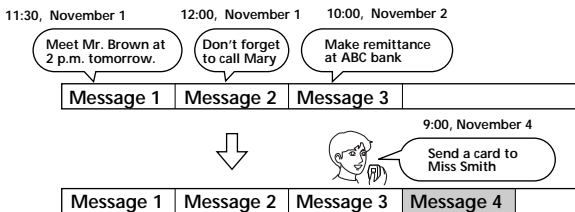

● Playback

With this IC recorder, you can quickly locate the message you want to play back.

Reviewing the current recording is also very easy.

● Erasing

You can quickly erase unwanted messages with an easy operation. When a message is erased, the next message automatically advances, leaving no blank space.

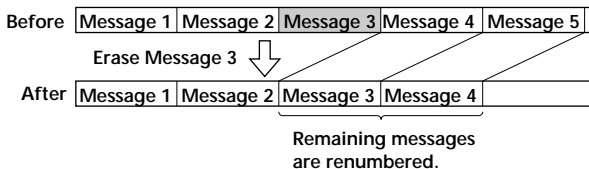

Features

- **16 minutes (SP)/32 minutes (LP) recording time**

As you can record for 32 minutes maximum (in LP mode), this unit is useful for recording messages, appointments or meetings.

- **Organizing message files**

You can choose among 3 different files to record and store your messages.

You can easily move messages from one file to another (see page 18).

Up to 99 messages can be recorded in each file.

- **Alarm function**

You can start playing back a desired message with an alarm on a desired date and time (see page 22). You can use this function to remind you of the time of the meeting, etc.

- **Playback speed control**

You can play back messages rapidly (+30%) or slowly (-15%) (see page 20). This is useful when playing back a long recording such as a meeting.

- **Adding a recording to previously recorded message**

You can add a recording to the message being played back to count as one message.

Step 1: Installing the Battery

1

Slide and lift the battery compartment lid.

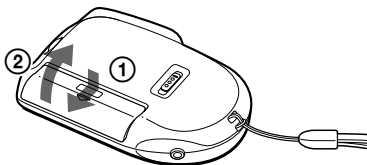

2

Insert a size AAA (LR03) alkaline battery with correct polarity, and close the lid.

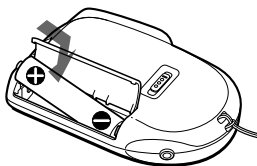

To take out the battery

Take out the battery by pushing the ⊖ side of it as illustrated.

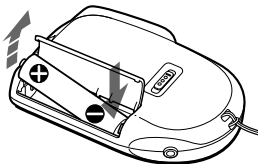

If the battery compartment lid is accidentally detached, attach it as illustrated.

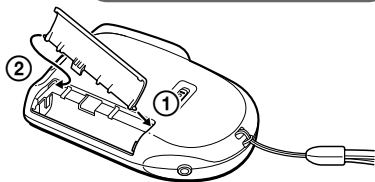

Clock setting display appears when you insert battery for the first time, or when you insert battery after the unit has been without battery for a certain period of time. Please refer to Steps 2 to 4 in “Step 2: Setting the Clock” on pages 8 and 9 to set the date and time.

Replacing the battery

“” appears on the display when the battery becomes weak and it flashes when the battery is exhausted. Replace the battery with a new one.

Battery life*

With continuous use, approx. 10 hours recording/5 hours playback

- * Using Sony alkaline battery LR03 (SG)
- * Using in LIGHT OP mode, playing back through the internal speaker with VOL control at around 3

The battery life may shorten depending on the operation of the unit.

Notes

- Do not use manganese batteries for this unit.
- When you replace the battery, insert the new one within 3 minutes after you removed the exhausted one. Otherwise, the display may show the clock setting display or incorrect date and time when you reinsert the battery. In this case, set the date and time again.
The recorded messages, however, will remain.
- Do not charge a dry battery.
- When you are not going to use the unit for a long time, remove the battery to prevent damage from battery leakage and corrosion.

Step 2: Setting the Clock

Clock setting display appears when you insert battery for the first time, or when you insert battery after the unit has been without battery for a certain period of time. In this case, proceed from step 2.

1 Display the clock setting display.

- ① Press MENU to enter the menu mode.*

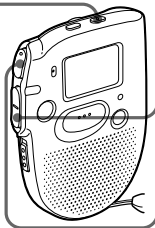
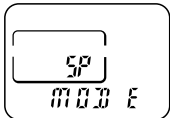

- ② Press -I◀◀ once to display "SET DATE".



- ③ Press ▶■PLAY/STOP. The year digits will flash.

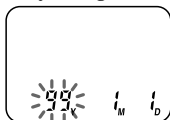

* The "ALARM" display may appear instead of the "MODE" display (see page 38).

2 Set the date.

- ① Press -I◀◀ or ▶▶+ to select the digits of the year.

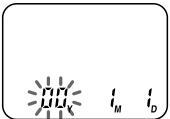

- ② Press ▶■PLAY/STOP. The month digits will flash.



- ③ Set the month and day in sequence, then press ▶■PLAY/STOP. The hour digits will flash.



3 Set the time.

- ① Press **←|←** or **→|→** to select the digits of the hour.



- ② Press **▶|■** **PLAY/STOP**.
The minute digits will flash.

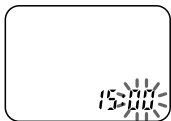

- ③ Set the minute.

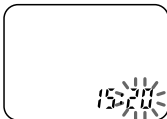

- ④ Press **▶|■** **PLAY/STOP** at the time signal.
The display will return to "SET DATE".



4 Exit from the menu mode.

Press **MENU**.

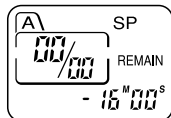

Recording Messages

You can record up to 99 messages in each file (A, B and C).

Since a newly recorded message is automatically added behind the last recorded message, you can start recording quickly without searching for the end of the last recording.

e.g.

Message 1	Message 2	Newly recorded message	Blank space
-----------	-----------	------------------------	-------------

1 Select the file.

Press FILE repeatedly until the the desired file is displayed.

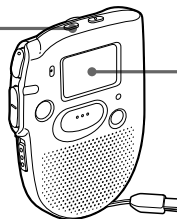

Current file

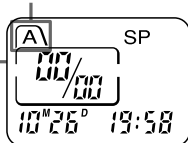

2 Start recording.

① Press REC START/STOP.

Current message number

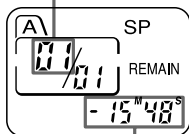

Remaining recording time

② Speak to the built-in microphone.

OPR indicator

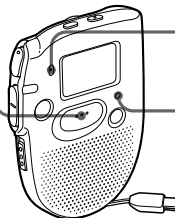

During recording, the OPR indicator lights up in red.

You do not need to keep pressing REC START/STOP while recording.

3 Stop recording.

Press REC START/STOP again.
The unit stops at the beginning
of the current recording.

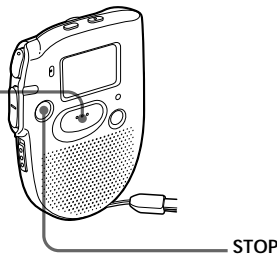
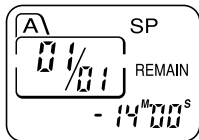

If you do not change the file after you stop recording, the next time you record you will record in the same file.

To listen to the current recording

Press REC START/STOP to stop recording, then press ►■PLAY/STOP.

To review the current recording instantly

Press ►■PLAY/STOP during recording.

To stop recording

You can also stop recording by pressing STOP instead of REC START/STOP.

To display the remaining recording time

During recording, the remaining recording time is displayed under REMAIN.

To display it during stop, press STOP for more than one second.

Continued

Recording Messages (continued)

Tips

- You can record for up to 16 minutes in SP (standard play) mode and 32 minutes in LP (long play) mode. If you record messages in a mixture of SP and LP modes, the recordable time varies from 16 to 32 minutes. To change the recording mode, see page 27.
- You can select the microphone sensitivity. See page 30.

Notes

- When the remaining time of recording reaches 1 minute, the remaining time and “END” will flash one after the other in the display window. When the memory is full, recording automatically stops and “FULL” will flash in the display window with an alarm sound. To continue recording, first erase some of the messages. (Page 16)
- If you press REC START/STOP when the memory is full, “FULL” will flash with an alarm sound. Erase some of the messages before you start recording again. (Page 16)
- If you press REC START/STOP after you have recorded 99 messages, “FULL” will flash with an alarm sound. Select another file or erase some of the messages. (Page 16)

Note on recording

Noise may be recorded if an object, such as your finger, etc., accidentally rubs or scratches the unit during recording.

Playing Back Messages

When playing back a previously recorded message, start from Step 1.
When playing back a message you have just finished recording, start from Step 3.

1 Select the file.

Press FILE repeatedly until the desired file is displayed.

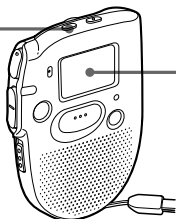

Current file

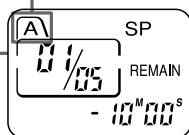

2 Select the message number.

Press \leftarrow or \rightarrow to display the desired message number.

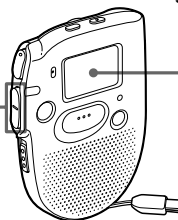

Selected message number

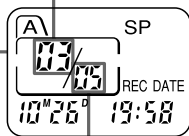

Total number of messages in the current file

for larger message number



for smaller message number



Continued

Playing Back Messages (continued)

3 Start playback.

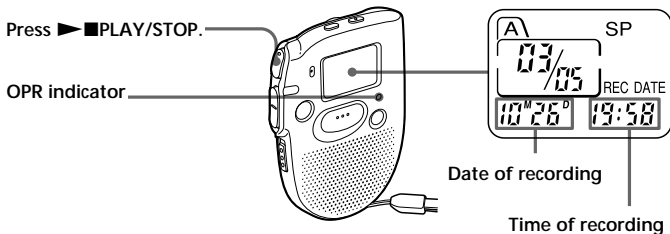

During playback, the OPR indicator lights up in green.

After playing back one message, the unit stops at the beginning of the next message.

When the last message on a file has been played back, the unit stops at the beginning of the last message.

4 Adjust the volume.

Turn VOL.



To stop playback

To	Do this
stop at the beginning of the current message	Press STOP.
stop at the current position (Playback Pause function)	Press ►■PLAY/STOP. To resume playback from that point, press ►■PLAY/STOP again.

Other operations

To	Do this
skip to the next message	Press ►►+.
skip to the previous message	Press -◄◄.
search forward during playback	Keep ►►+ pressed.
search backward during playback	Keep -◄◄ pressed.

Playing back a message repeatedly — Repeat Play

During playback, press ►■PLAY/STOP for more than one second. “↺” will be displayed and the selected message will be played back repeatedly until you stop playback by pressing STOP.

Playing the beginning of each message — Scanning Play

During stop mode, press ►■PLAY/STOP for more than one second. “SCAN” will be displayed in the display window and the first 5 seconds of each message in the selected file will be played back. When you find the desired message, press ►■PLAY/STOP. The message will be played back until the end.

For private listening

Connect an earphone (not supplied) to the EAR jack. The built-in speaker will be automatically disconnected.

Erasing Messages

You can erase the recorded messages one by one or all messages in a file at a time.

Note that once a recording has been erased, you cannot retrieve it.

Erasing messages one by one

When a message is erased, the remaining messages will advance and renumbered so that there will be no space between messages.

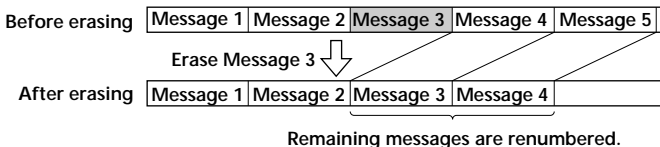

- ① Press ERASE while playing back the message you want to erase or press ERASE for more than 1 second during stop mode. A beep will sound and the message number and "ERASE" will flash while the first and last 5 seconds of the message is played back 10 times.

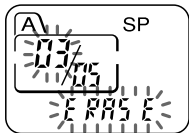

- ② Press ERASE while the message is being played back. The message is erased and the remaining messages will be renumbered.

To cancel erasing

Press STOP before step ②.

To erase other messages

Repeat steps ① and ②.

Erasing all messages in a file

e.g.

File A

Message 1	Message 2	Message 3	Blank space
-----------	-----------	-----------	-------------

File B

Message 1	Message 2	Message 3
-----------	-----------	-----------

Blank space

Message 1	Message 2	Message 3
-----------	-----------	-----------

- ① Press FILE to select the file you want to erase.

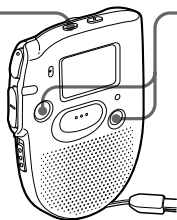

- ② Press ERASE and STOP at the same time for more than 1 second. The file, the message number and "ALL ERASE" will flash.

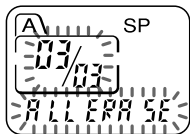

- ③ Press ERASE.

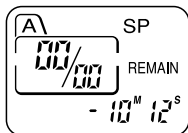

To cancel erasing

Press STOP before step ③.

► Advanced Operations

Moving Messages to a Different File — Move Function

You can move recorded messages to a different file.

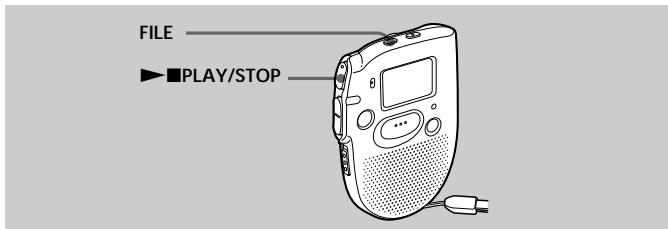

e.g. To move the seventh message in the file A to the file C

- 1 Play back the message you want to move.

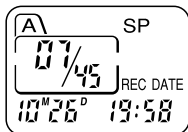

- 2 Press FILE during playback to select the file you want to move the message to. The file and "MOVE" will flash and the first and last 5 seconds of the message will be played back 10 times.

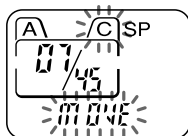

- 3 Press ▶ ■ PLAY/STOP.

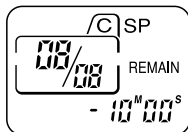

To cancel moving the message(s)

Press STOP before step 3.

Notes

- The move function does not duplicate a message in another file. When you move a message to another file, the one in the previous file will be deleted.
- If you do not press ►■PLAY/STOP while the first and last 5 seconds of the message are played back, the display will return to the REMAIN display. In this case, start the procedure from the beginning.

Adjusting the Playback Speed

You can adjust the speed of the playback with the use of the PLAY SPEED selector on the bottom.

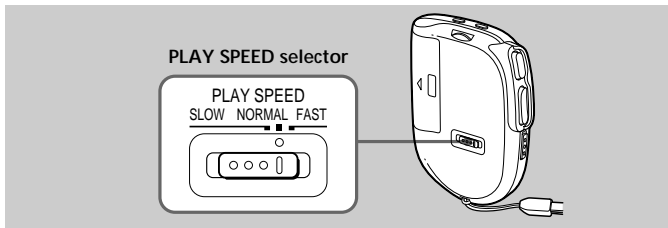

To play back rapidly

Set PLAY SPEED to FAST.

“FAST” will flash three times in the display window and the playback speed will increase about 30%.

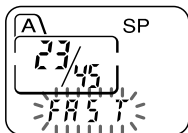

To play back slowly

Set PLAY SPEED to SLOW.

“SLOW” will flash three times in the display window and the playback speed will decrease about 15%.

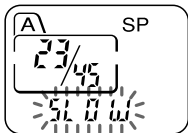

To play messages with normal speed

Set PLAY SPEED to NORMAL.

Adding a Recording to a Previously Recorded Message

You can add a recording to the message being played back. The added recording will be placed after the current message and counted as a part of the message.

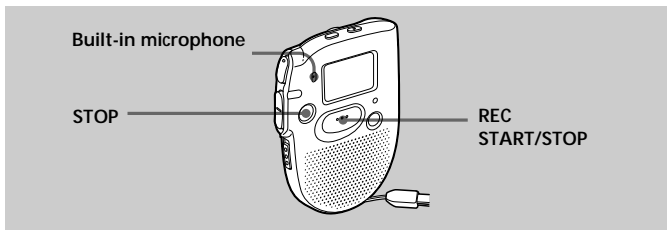
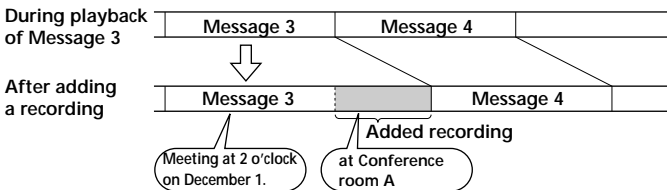

- 1 During playback, press **REC START/STOP** for more than 1 second. The OPR indicator lights in red and “R-PLUS” flashes three times. Speak into the built-in microphone. The display will then change to the remaining recording time.
- 2 Press **REC START/STOP** again to stop the recording.

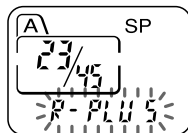

To stop recording

You can also stop recording by pressing **STOP** instead of **REC START/STOP**.

Playing Back a Message at a Desired Time with an Alarm

You can sound an alarm and start playback of a selected message at a desired time.

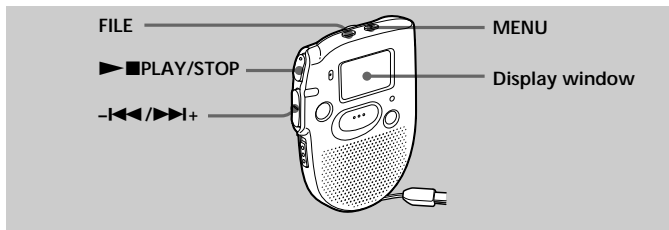

- 1 Use FILE and -|<<</>>>|+ to select the file and the message you want to play back.

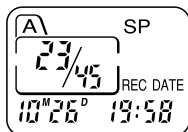

- 2 Enter the alarm setting mode.

- ① Press MENU.

The unit enters the menu mode and "ALARM OFF" will be displayed. (If "ALARM On" is displayed, the alarm has been set. If you do not wish to change the setting, press MENU and exit the menu mode.)

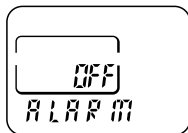

Note

"ALARM OFF (or On)" will not appear and the alarm cannot be set if the clock has not been set or no message has been recorded in the selected file.

- ② Press ►■PLAY/STOP.
"OFF" starts to flash.

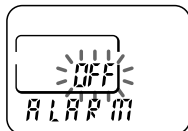

- ③ Press **-|◀◀** or **▶▶|+** to flash "On".

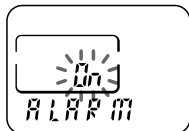

- ④ Press **▶■**PLAY/STOP.
"DATE" will flash in the display window.

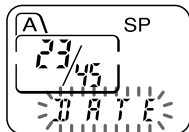

3 Set the alarm date.

- **to play back on a desired date**
(the message will be played back at the same time on the same date every year until you erase the message)

- ① Press **▶■**PLAY/STOP when "DATE" flashes.

The month digits will flash.

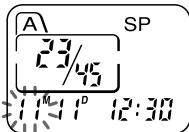

- ② Press **-|◀◀** or **▶▶|+** to select the month digits and press **▶■**PLAY/STOP.
The day digits will flash.

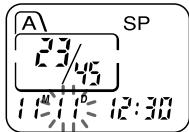

- ③ Press **-|◀◀** or **▶▶|+** to select the day digits.

- **to play back once a week**

Press **-|◀◀** or **▶▶|+** to select the day of the week.

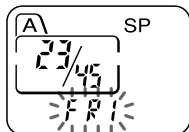

- **to play back at the same time every day**
Press **-|◀◀** or **▶▶|+** to select "DAILY".

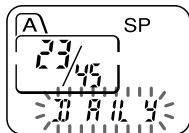

Continued

Playing Back a Message at a Desired Time with an Alarm (continued)

- 4** Press **▶■**PLAY/STOP.
The hour digits will flash.

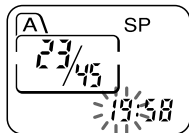

- 5** Set the alarm time.

- ① Press **-I◀** or **▶I+** to select the hour digits and press **▶■**PLAY/STOP.
The minute digits will flash.

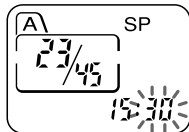

- ② Press **-I◀** or **▶I+** to select the minute digits and press **▶■**PLAY/STOP.

“ALARM On” and “(●)” will be displayed to indicate that the setting has been completed.

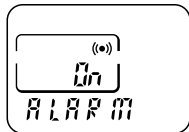

- 6** Press **MENU** to exit the menu mode.

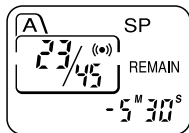

“(●)” is displayed when the number of the message with alarm setting is selected.

At the set time, the alarm will sound for about 10 seconds and the selected message will be played back.

During playback, “ALARM” will flash in the display window.
Playback will stop at the end of the message.

To cancel the alarm setting before the playback starts

Press **STOP** while the alarm sound is heard. You can stop even when the **HOLD** function is activated.

Notes

- You cannot set the alarm if you have not set the clock or there is no message in the selected file (the unit will not enter the alarm setting mode when you press MENU in Step 2 on page 22).
- If you try to set the alarm to play back a message at a previously set time on another message, "PRE SET" will be displayed, preventing new settings.
- If the alarm time comes while another message is being played back with an alarm, the playback stops and the new message will be played back.
- If the alarm time comes during recording, alarm will sound for 10 seconds after the recording is finished and playback begins. "(●)" will flash when the alarm time comes.
- If more than one alarm time comes during recording, only the first message will be played back.
- If the alarm time comes when the unit is in the menu mode, alarm will sound and the menu mode will be cancelled.
- If you erase the message you set the alarm to play back, the alarm setting will be cancelled.
- You can adjust the playback volume with the VOL control.
- If the alarm time comes during erasing, alarm will sound for 10 seconds after the erasing is finished and playback begins.
- Alarm setting will not be cancelled when the alarm playback finishes. To cancel alarm setting, see below.

To cancel the alarm setting or change the alarm time

- 1 Select the message you set the alarm to play back, and press MENU. "ALARM On" will be displayed.
- 2 Press ►■PLAY/STOP to flash "On".
- 3 **To cancel the alarm setting:** Press -|◀◀ or ►►|+ to flash "OFF" and press ►■PLAY/STOP.
To change the alarm date and time: Press ►■PLAY/STOP. When the alarm date is displayed, follow the steps 3 to 5 on pages 23 and 24 to change the alarm date and time.
- 4 Press MENU to exit the menu mode.

Preventing Accidental Operation — HOLD function

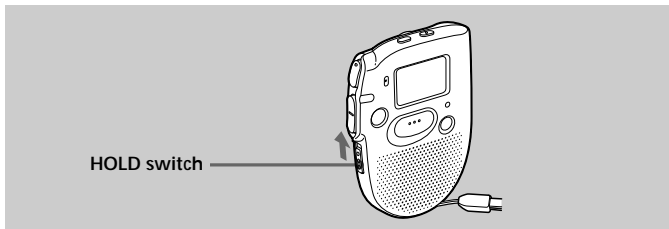

Slide the HOLD switch in the direction of the arrow. "HOLD" will flash three times, indicating that all the functions of the buttons are locked, except for STOP to stop an alarm.

To cancel the HOLD function, simply slide the HOLD switch in the opposite direction.

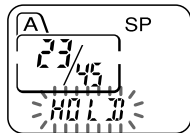

Note

When the HOLD function is activated during recording, cancel the HOLD function first to stop recording.

Selecting the Recording Mode

MODE SP: You can make up to 16 minutes of recording with better sound.

MODE LP: You can make up to 32 minutes of recording.

1 Press MENU to enter the menu mode.

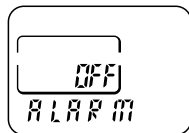

2 Press -|◀◀ or ▶▶|+ to display "MODE" and press ▶■PLAY/STOP. "SP (or LP)" will flash.

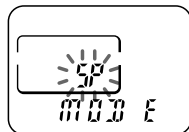

3 Press -|◀◀ or ▶▶|+ to select "SP" or "LP" and press ▶■PLAY/STOP. Now the setting is completed.

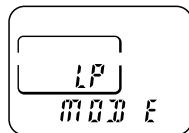

4 Press MENU to exit the menu mode.

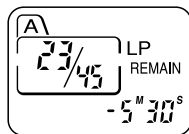

Turning off the Beep Sound

BEEP On: A beep will sound to indicate that operation has been accepted.

BEEP OFF: No beep sound will be heard except for the alarm and timer.

- 1** Press MENU to enter the menu mode.

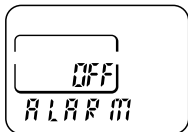

- 2** Press -I◀◀ or ▶▶I+ to display "BEEP On (or OFF)" and press ►■PLAY/STOP. "On (or OFF)" will flash.

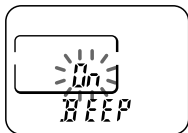

- 3** Press -I◀◀ or ▶▶I+ to select "On" or "OFF" and press ►■PLAY/STOP. The setting is completed.

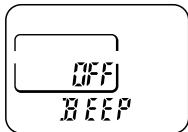

- 4** Press MENU to exit the menu mode.

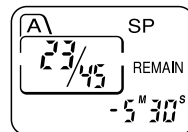

What beep sound means

Beep patterns	Meaning
- (single tone)	Usual mode
-- (double tone)	Enter/exit special mode
--- (triple tone)	Notice*
---- ---- (continuous beep)	Alarm set time has come.

* This pattern lets you know the procedure is wrong or informs you of some messages, such as:

- you are trying to record a message when you have already recorded up to the maximum recordable time or the maximum number of messages.
- the unit has stopped functioning due to lack of battery power.

Selecting the Microphone Sensitivity

SENS H (high): To record at meetings or in a quiet and/or spacious place.

SENS L (low): To record for dictation or in a noisy place.

- 1** Press MENU to enter the menu mode.

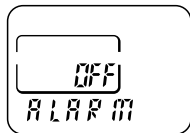

- 2** Press -|<<< or >>>+ to display "SENS" and press ►■PLAY/STOP. "H (or L)" will flash.

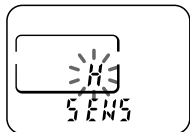

- 3** Press -|<<< or >>>+ to select "H" or "L" and press ►■PLAY/STOP. Now the setting is completed.

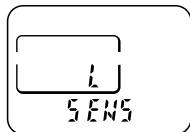

- 4** Press MENU to exit the menu mode.

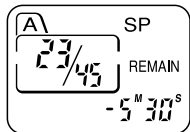

Playing Back All Messages in a File Continuously

CONT On: You can play back all messages in a file continuously.

CONT OFF: Playback stops at the end of each message.

- 1** Press MENU to enter the menu mode.

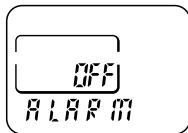

- 2** Press -|◀◀ or ▶▶+ to display "CONT" and press ▶■PLAY/STOP. "OFF (or On)" will flash.

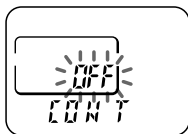

- 3** Press -|◀◀ or ▶▶+ to select "On" or "OFF" and press ▶■PLAY/STOP.

Now the setting is completed.

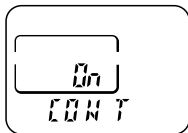

- 4** Press MENU to exit the menu mode.

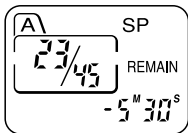

Selecting the Illumination Mode of LCD Back Light

LIGHT OP: The display window is illuminated for 3 seconds after each operation.

LIGHT All: The display window is illuminated at all times during operation.

- 1** Press MENU to enter the menu mode.

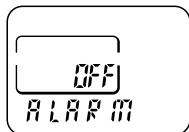

- 2** Press -I◀◀ or ▶▶+ to display "LIGHT" and press ▶■PLAY/STOP. "OP (or All)" will flash.

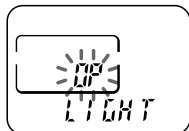

- 3** Press -I◀◀ or ▶▶+ to select "OP" or "All" and press ▶■PLAY/STOP.

Now the setting is completed.

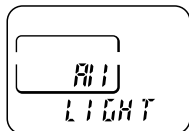

- 4** Press MENU to exit the menu mode.

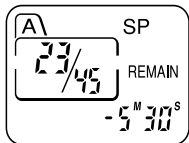

When the unit is not being operated (when the display shows the current time), you can illuminate the display window by pressing STOP. This enables you to check the time even in a dark place.

Note

The effect of the illumination may be reduced in a bright location.

Precautions

On power

- Operate the unit only on 1.5 V DC. Use one size AAA (LR03) alkaline battery.

On safety

- Do not operate the unit while driving, cycling or operating any motorized vehicle.

On handling

- Do not leave the unit in a location near heat sources, or in a place subject to direct sunlight, excessive dust or mechanical shock.
- Should any solid object or liquid fall into the unit, remove the batteries and have the unit checked by qualified personnel before operating it any further.

On noise

- Noise may be heard when the unit is placed near an AC power source, a fluorescent lamp or a mobile phone during recording or playback.
- Noise may be recorded when an object, such as your finger, etc., rubs or scratches the unit during recording.

On maintenance

- To clean the exterior, use a soft cloth slightly moistened in water. Do not use alcohol, benzine or thinner.

Keep personal credit cards using magnetic coding or spring-wound watches, etc., away from the unit to prevent possible damage from the magnet used in the speaker.

If you have any questions or problems concerning your unit, please consult your nearest Sony dealer.

Troubleshooting

Should any problem persist after you have made these checks, consult your nearest Sony dealer.

Symptom	Remedy
The unit does not operate.	<ul style="list-style-type: none">•The batteries have been inserted with incorrect polarity.•The batteries are weak.•The buttons are locked with the HOLD switch. (If you press any button, "HOLD" will flash three times.
No sound comes from the speaker.	<ul style="list-style-type: none">•The earphone is plugged in.•The volume is turned down completely.
"FULL" is displayed and you cannot start recording.	<ul style="list-style-type: none">•The memory is full. Erase some of the messages. See page 16.•99 messages have been recorded in the selected file. Select another file or erase some of the messages. See page 16.
Noise is heard.	<ul style="list-style-type: none">•An object, such as your finger, etc., accidentally rubbed or scratched the unit during recording so that noise was recorded.•The unit was placed near an AC power source, a fluorescent lamp or a mobile phone during recording or playback.•Earphone plug is dirty. Clean the plug.
Recording level is low.	<ul style="list-style-type: none">•Microphone sensitivity is set to "SENS L". Set it to "SENS H". See page 30.
Playback speed is too fast or too slow.	<ul style="list-style-type: none">•Set the PLAY SPEED switch to "NORMAL". See page 20.
"--M--D --:--" is displayed.	<ul style="list-style-type: none">•You have not set the clock. See page 8.
"--M--D" is displayed on the REC DATE display.	<ul style="list-style-type: none">•The date of recording will not be displayed if you recorded the message when the clock was not set.
The unit does not operate correctly.	<ul style="list-style-type: none">•Take out the battery and insert it again.

Specifications

Recording media	Built-in flash memory, Monaural recording
Recording time	SP: 16 minutes LP: 32 minutes
Frequency response	SP: 250 Hz - 3,400 Hz LP: 250 Hz - 2,500 Hz
Speaker	approx. 3.6 cm (1 ⁷ / ₁₆ in.) dia.
Power output	80 mW
Output	Earphone jack (mini jack) for 8 - 300 ohms earphone
Playback speed control	FAST: +30% SLOW: -15%
Power requirements	One size AAA (LR03) alkaline battery: 1.5 V DC
Dimensions (w/h/d) (not incl. projecting parts and controls)	58.0 × 83.5 × 14.2 mm (2 ³ / ₈ × 3 ³ / ₈ × ⁹ / ₁₆ in.)
Mass (incl. battery)	58 g (2.0 oz)
Supplied accessories	Size AAA (LR03) alkaline battery × 1 Handstrap (attached to the unit) × 1
Optional accessories	Active speakers SRS-T1

Design and specifications are subject to change without notice.

Index to Parts and Controls

Refer to the pages indicated in parentheses for details.

Main unit

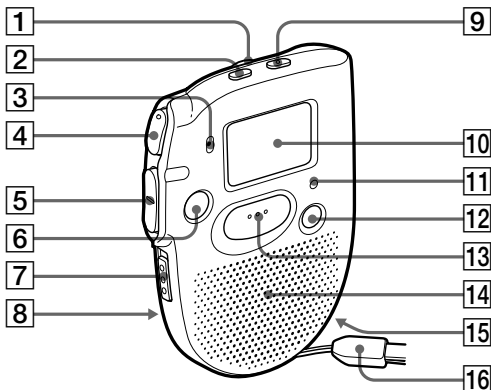

- | | |
|--------------------------------------------------------------------------------------|-----------------------------------------------|
| 1 VOL (volume) control (14) | 9 MENU button (8, 22, 38) |
| 2 FILE button (10, 13, 18) | 10 Display window (37) |
| 3 MIC (built-in microphone) (10) | 11 OPR (operation) indicator (10, 14) |
| 4 ►■PLAY/STOP (play/stop•enter) button (8, 14, 15) | 12 ERASE button (16) |
| 5 -◀◀/▶▶+ (fast forward/fast backward•selection of menu mode) button (13, 15) | 13 REC (record) START/STOP button (10) |
| 6 STOP button (11) | 14 Speaker |
| 7 HOLD switch (26) | 15 EAR (earphone) jack (15) |
| 8 PLAY SPEED selector (20) | 16 Hand strap |

Display window

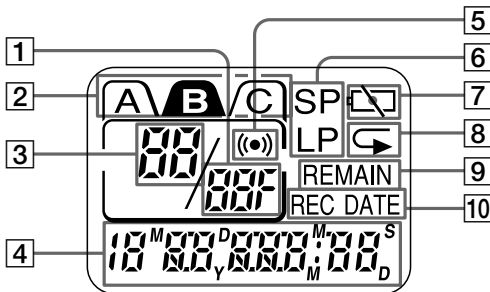

- | | |
|----------------------------------------------------------------------------------------------------------------------------------------------------------------------------------------------------------------------------------------------------------------------------------------------------------------------------------------------------------------------------------------------------------------------------------------------------------|-----------------------------------------------------------------------------------------------------------------------------------------------------------------------------------------------------------------------------------------------------------------|
| <p>1 Total number of messages in a file (13)
Mode indication of the menu (22, 27 - 32) (On, OFF, etc.)</p> <p>2 File indication (10, 13)</p> <p>3 Current message number (10, 13)</p> <p>4 Remaining recording time indication (10)
Recording date indication (14)
Current time/day indication (8) (15:30 TUE, etc.)
Menu indication (8, 22, 27 - 32, 38) (ALARM, etc.)
Messages (ERASE, SCAN, etc.)</p> | <p>5 Alarm indicator (24)</p> <p>6 Recording mode indication (27)</p> <p>7 Battery exhausted indicator (7)</p> <p>8 Repeat play indicator (15)</p> <p>9 REMAIN indication (10)</p> <p>10 REC DATE indication (14)</p> |
|----------------------------------------------------------------------------------------------------------------------------------------------------------------------------------------------------------------------------------------------------------------------------------------------------------------------------------------------------------------------------------------------------------------------------------------------------------|-----------------------------------------------------------------------------------------------------------------------------------------------------------------------------------------------------------------------------------------------------------------|

Menu map

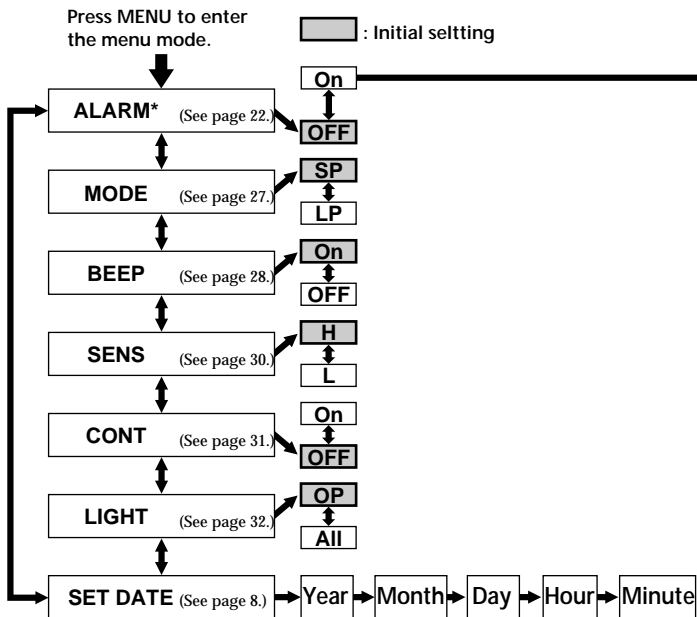

* The "ALARM" display will not appear if you have not set the date and time or if there is no recorded message.

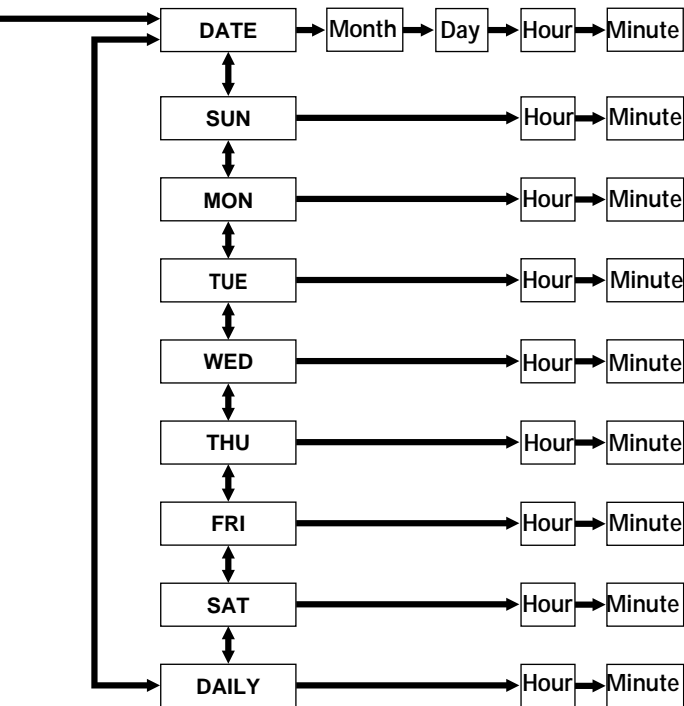

Index

A

- Accidental operation 26
- Alarm 22

B

- Back light 32
- Battery 6
- Beep 28
- Built-in microphone 10

C

- Clock setting 8

D

- Display window 37

E

- Earphone 15
- Erase 16

F, G

- Fast backward 15
- Fast forward 15
- File 10, 13, 17, 18

H

- Hold 26

I

- IC memory 4

J, K, L

- LP mode 27

M, N, O

- Menu 8, 22, 38
- Message, erasing 16
- Message, playing back 13
- Message, recording 10
- Message number 10
- Microphone, built-in 10
- Microphone sensitivity 30
- Move 18

P, Q

- Playback 13
- Playback Pause function 15
- Playback speed 20

R

- Recording 10
- Recording mode 27
- Remaining time 10
- Repeat play 15

S, T, U

- Scanning play 15
- SP mode. 27
- Stop 11, 15

V, W, X, Y, Z

- Volume control 14