

# CONTAX



Instruction manual • Bedienungsanleitung  
Mode d'emploi • Manual de instrucciones

*Aria*

*Thank you for your purchase of the Contax Aria, the latest addition to the Contax tradition of great picture making tools. The Aria is a compact, lightweight, multi-mode AE SLR camera featuring an evaluative metering system that can automatically provide exposure compensation for backlighted subjects. Before using the camera, please read through this instruction manual carefully so that you will be able to handle it correctly for long and troublefree operation.*

Although the descriptions in this manual assume the use of a multi-mode planar T\* 50 mm F1.4 (MM) lens, the operating procedures for other Carl Zeiss interchangeable lenses designed for use with Contax 35 mm SLR cameras are the same unless otherwise specified.

### **<Packing List>**

Make sure that the package contains the following items.

1. Eyecup F-3 .....	1
2. Lithium batteries (CR2).....	2
3. Strap set .....	1
4. Instruction manual (this manual) .....	1
5. Contax warranty card.....	1
6. List of customizable features .....	1

# Contents

Names of Parts .....	14
Quick Guide to Shooting (Automatic Exposure) .....	18
Attaching the Eyepiece Cover and Strap .....	22
Attaching the Eyecup .....	24

## ● Basic Operations Before Shooting

Loading the Batteries .....	26
<Battery Check>	
<Battery Replacement>	
Mounting and Dismounting the Lens .....	34
Main Switch .....	38
Viewfinder Display and Display Panel .....	40
Loading the Film .....	54
Setting the Film Speed .....	58
<Checking the Film Speed>	
Exposure Mode Selector Lever .....	68
Drive Mode Button .....	70
Shutter Speed Dial .....	76
Metering Mode Selector Lever .....	78
Focusing the Lens .....	80
Holding the Camera .....	84
Rewinding the Film .....	86
Shutter Speed and Aperture Indicators .....	90

## ● Taking Pictures

Selecting the Exposure Mode .....	92
Aperture-priority Auto Exposure [Av] .....	96
Shutter-speed-priority Auto Exposure [Tv] .....	98
Programmed Auto Exposure [P] .....	104
Manual Exposure [M] .....	112
Bulb Exposure [B] .....	114

## ● Miscellaneous Shooting Techniques

Metering System .....	116
Exposure Compensation .....	126
<1. Using the Exposure Compensation Dial>	
<2. Using the AE Lock>	
<3. Using the A.B.C. Mode (Automatic Exposure Compensation for 3 Consecutive Frames)>	
Flash Photography .....	146
<Taking Pictures on TTL Direct Light Metering>	
<Slow Shutter Synchronization>	
<Daylight Flash>	
<Second Curtain Synchronization>	
<Taking Pictures Using X-contact Flash Units Other than TLA Flash Unit>	
Multiple Exposure .....	164
Using the Self-timer .....	170

## ● Other Functions

Custom Functions .....	174
<List of Custom Functions>	
Setting the Custom Functions .....	182
Release Socket .....	186
Detaching the Camera Back .....	188
Aperture Stop-down Button .....	190
Basic Photographic Concepts .....	192
Exposure, Shutter Speed, Aperture Value, Film Speed, Depth of Field	
Camera Care and Precautions .....	196

## ● Optional Accessories

Contax TLA360 Flash Unit .....	202
Contax Data Back D-9 (multi-function type) .....	212
Contax Power Pack Adapter GP-1 .....	220
FU Type Focusing Screens .....	226
FL Type Diopter Lenses .....	234
Flex Case C-6 .....	236
Specifications .....	238
In Case of Difficulty .....	247

## Names of Parts

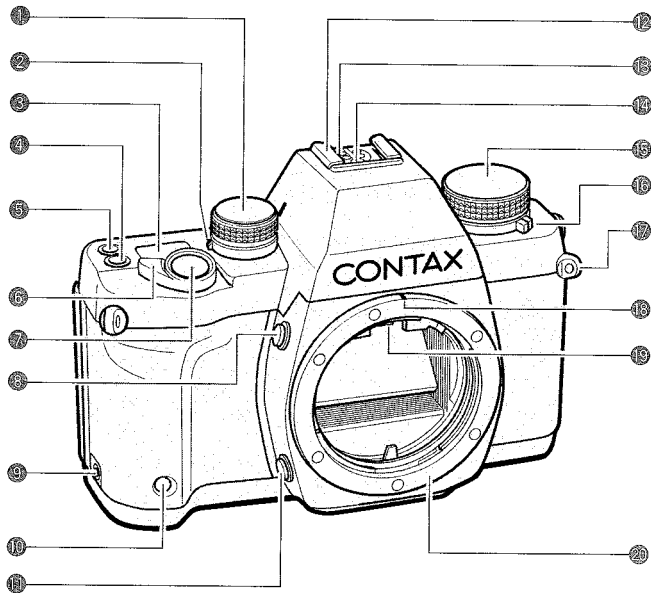

- ① Exposure Compensation Dial (P. 126)
- ② A.B.C. Lever (P. 140)
- ③ Display Panel (P. 50)
- ④ ISO Button/"UP" Button (P. 64)
- ⑤ Drive Mode Button/"DOWN" Button (P. 70)
- ⑥ Main Switch (P. 38)
- ⑦ Shutter Release
- ⑧ Lens Release Button (P. 36)
- ⑨ Release Socket (P. 186)
- ⑩ Self-timer LED (P. 170)
- ⑪ Aperture Stop-down Button (P. 190)
- ⑫ Accessory Shoe (P. 146)
- ⑬ Dedicated Flash Contact
- ⑭ Direct X-contact
- ⑮ Shutter Speed Dial (P. 76)
- ⑯ Exposure Mode Selector Lever (P. 68)
- ⑰ Strap Lug (Attaching the Strap, P. 22)
- ⑱ Lens Index (P. 34)
- ⑲ Screen Release Claw (P. 230)
- ⑳ Mount

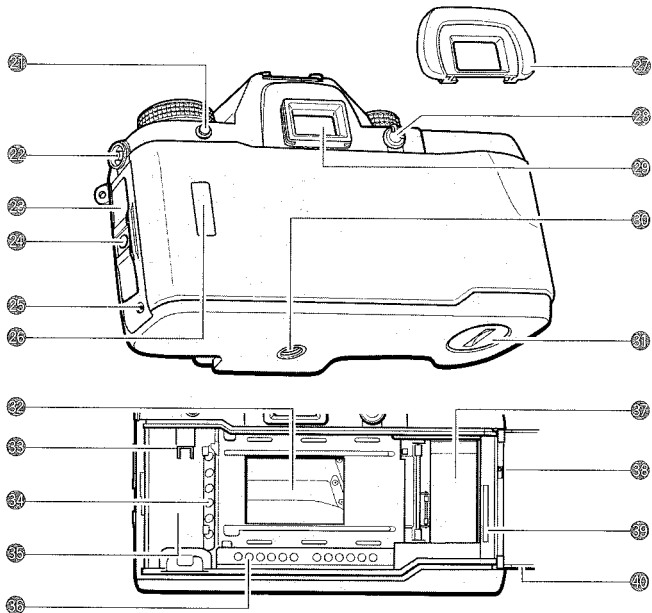

- 21 Exposure Mode Lock Release Button (P. 68)
- 22 Sync Terminal
- 23 Camera Back Opening Lever (P. 54)
- 24 Camera Back Lock Release Button (P. 54)
- 25 Manual Rewind Button (P. 86)
- 26 Film Check Window
- 27 Eyecup (P. 24)
- 28 Metering Mode Selector Lever (P. 78)
- 29 Viewfinder Eyepiece (P. 40)
- 30 Tripod Socket
- 31 Battery Compartment, Battery Compartment Cover (P. 26)
- 32 Shutter Curtain (P. 54)
- 33 Film Mounting Spindle
- 34 DX Contact
- 35 Film Chamber
- 36 Data Back Contacts
- 37 Spool
- 38 Camera Back Release Pin (P. 188)
- 39 Film Leader Mark (P. 56)
- 40 Camera Back

# Quick Guide to Shooting (Automatic Exposure)

## Kurzanleitung zum Fotografieren (Belichtungsautomatik)

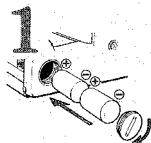

**1**  
**Load the batteries**  
(P. 26).

**Legen Sie die Batterien ein**  
(S. 27).

**Mettez les piles en place**  
(P. 27).

**Inserte las pilas**  
(P. 27).

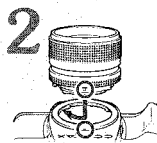

**2**  
**Mount the lens**  
(P. 34).

**Setzen Sie das Objektiv ein**  
(S. 35).

**Montez l'objectif**  
(P. 35).

**Monte el objetivo**  
(P. 35).

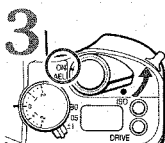

**3**  
**Turn on the main switch**  
(P. 38).

**Schalten Sie die Kamera ein**  
(S. 39).

**Activez l'interrupteur principal**  
(P. 39).

**Conecte el interruptor principal**  
(P. 39).

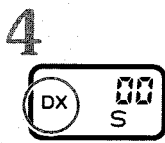

**4**  
**Set the film speed to "DX"**  
(P. 60).

**Stellen Sie die Filmempfindlichkeit auf "DX"**  
(S. 61).

**Réglez la sensibilité du film sur "DX"**  
(P. 61).

**Ajuste a sensibilidad de la película a "DX"** (P. 61).

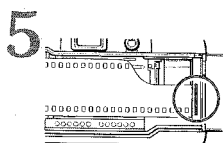

**5**  
**Load DX film.**  
Pull out the film leader as far as the orange "I" mark. Place it on the spool and shut the camera back (P. 54).

**Legen Sie den DX-Film ein.**  
Ziehen Sie die Lasche des Filmanfangs bis zur orange-farbenen Markierung "I" heraus. Legen Sie den Film über die Aufwickelspule und schließen Sie die Rückwand (S. 55).

**Installez le film DX.**  
Tirez son amorce jusqu'au repère "I" orange. Placez l'amorce sur la bobine réceptrice et refermez le dos de l'appareil (P. 55).

**Inserte la película DX.**  
Saque la parte de película guía hasta la marca "I" de color naranja. Colóquela en el carrete y cierre el respaldo de la cámara (P. 55).

# Guide résumé de la prise de vue (Exposition automatique)

## Guía rápida para fotografiar (exposición automática)

6

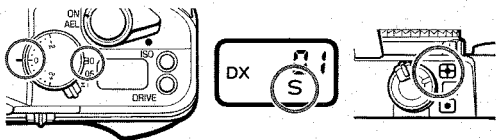

### Set each mode as shown in the illustrations.

Set the exposure compensation dial to "0" (P. 126).

Set the A.B.C lever to "0" (P. 140).

Set Drive Mode to "S" (P. 70).

Set the metering mode selector lever "☀" (P. 78).

### Stellen Sie die verschiedenen Betriebsarten wie in den Abbildungen gezeigt ein.

Stellen Sie den Belichtungskorrekturring auf "0" (S. 127).

Stellen Sie den Belichtungsreihen (A.B.C.)-Hebel auf "0" (S. 141).

Stellen Sie die Filmtransporttaste auf "S" ein (S. 71).

Stellen Sie den Meßartenhebel auf "☀" (S. 79).

### Réglez chaque mode comme indiqué sur les illustrations.

Réglez le barillet de correction d'exposition sur "0" (P. 127).

Réglez le levier A.B.C sur "0" (P. 141).

Réglez le mode d'entraînement sur "S" (P. 71).

Réglez le sélecteur du mode de mesure sur "☀" (P. 79).

### Ajuste cada modo como se muestra en las ilustraciones.

Ajuste el aro de compensación de la exposición a "0" (P. 127).

Ajuste la palanca A.B.C. a "0" (P. 141).

Ajuste el modo motorizado a "S" (P. 71).

Ajuste la palanca selectora del modo de medición "☀" (P. 79).

Aperture-priority auto exposure (P. 96)

Zeitautomatik mit Blendenvorwahl (S. 97)

Exposition automatique à priorité au diaphragme (P. 97)

Exposición automática con prioridad en la abertura (P. 97)

Av

Shutter-speed-priority auto exposure (P. 98)

(only when MM lens is used)

Blendenautomatik mit Zeitvorwahl (S. 99)

(nur mit MM-Objektiven)

Exposition automatique à priorité à la vitesse (P. 99)

(seulement avec un objectif MM)

Exposición automática con prioridad en la velocidad del obturador (P. 99) (Sólo cuando se emplea el objetivo MM)

Tv

Programmed auto exposure (P. 104)

(only when MM lens is used)

Programmautomatik (S. 105)

(nur mit MM-Objektiven)

Exposition automatique programmée (P. 105)

(seulement avec un objectif MM)

Exposición automática programada (P. 105)

(Sólo cuando se emplea el objetivo MM)

P

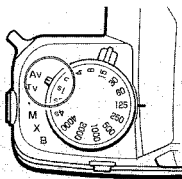

**7****Av**

Set the exposure mode selector lever to “Av” (P. 96).

Stellen Sie den Belichtungsartenhebel auf “Av” (S. 97).

Réglez le sélecteur du mode d'exposition sur “Av” (P. 97).

Ajuste la palanca selectora del modo de exposición a “Av” (P. 97).

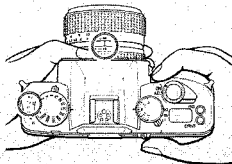
**7****Tv**

Set the exposure mode selector lever to “Tv” and set minimum lens aperture (green) (P. 98).

Stellen Sie den Belichtungsartenhebel auf “Tv” und dann die Blende auf den kleinsten Wert (grün) (S. 99).

Réglez le sélecteur du mode d'exposition sur “Tv” et réglez au diaphragme minimum (vert) (P. 99).

Ajuste la palanca selectora del modo de exposición a “Tv” y ajuste la abertura mínima del objetivo (verde) (P. 99).

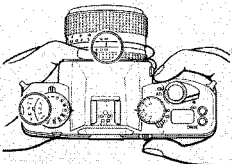
**7****P**

Set the exposure mode selector lever to “P” and set minimum lens aperture (green) (P. 104).

Stellen Sie den Belichtungsartenhebel auf “P” und dann die Blende auf den kleinsten Wert (grün) (S. 105).

Réglez le sélecteur du mode d'exposition sur “P” et réglez au diaphragme minimum (vert) (P. 105).

Ajuste la palanca selectora del modo de exposición a “P” y ajuste la abertura mínima del objetivo (verde) (P. 105).

8

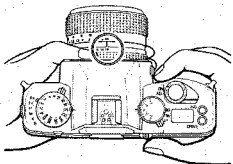

Set the aperture (P. 96).

Wählen Sie eine Blende  
(S. 97).

Réglez le diaphragme  
(P. 97).

Ajuste la abertura (P. 97).

9

Focus, compose the picture and shoot.

Fokussieren Sie das Motiv, legen Sie den  
gewünschten Bildausschnitt fest und  
lösen Sie dann aus.

Effectuez la mise au point, composez  
l'image et déclenchez.

Enfoque, componga la imagen, y dispare.

8

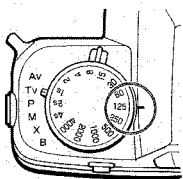

Set the shutter speed  
(P. 98).

Wählen Sie eine  
Verschlußzeit ( S. 99).

Réglez la vitesse  
d'obturation (P. 99).

Ajuste la velocidad del  
obturador (P. 99).

9

Focus, compose the picture and shoot.

Fokussieren Sie das Motiv, legen Sie den  
gewünschten Bildausschnitt fest und  
lösen Sie dann aus.

Effectuez la mise au point, composez  
l'image et déclenchez.

Enfoque, componga la imagen, y dispare.

8

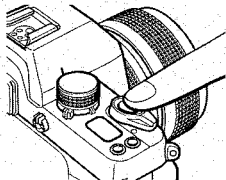

Focus, compose the picture and shoot.

Fokussieren Sie das Motiv, legen Sie den gewünschten  
Bildausschnitt fest und lösen Sie dann aus.

Effectuez la mise au point, composez l'image et déclenchez.

Enfoque, componga la imagen, y dispare.

## Attaching the Eyepiece Cover and Strap

First thread the strap through the eyepiece cover. Then attach the strap as shown in the illustration below. When it is not possible to keep your eye at the viewfinder such as when using the self-timer or Cable Switch L, attach the eyepiece cover to prevent stray light from entering through the eyepiece and adversely affecting exposure.

## Anbringen von Okulardeckel und Tragriemen

Führen Sie den Tragriemen zunächst durch den Okulardeckel. Dann bringen Sie ihn wie in der Abbildung gezeigt an. Wenn das Sucherokular offenliegt, z.B. bei Gebrauch des Selbstauslösers oder Kabelauslösers L, bringen Sie den Okulardeckel an, um zu verhindern, daß die Belichtung durch Streulicht, das in das Okular eindringt, beeinträchtigt wird.

- ① Attach the protective cover to the strap lug.
  - ② Attach the triangular ring to the strap lug.
  - ③ Thread the strap through the protective cover and the triangular ring and attach as shown in the illustration.
- ① Befestigen Sie den Schutzdeckel an der Tragriemenöse.
- ② Befestigen Sie den dreieckigen Ring an der Tragriemenöse.
- ③ Führen Sie den Tragriemen durch den Schutzdeckel und den dreieckigen Ring und befestigen Sie den Tragriemen dann wie in der Abbildung gezeigt.

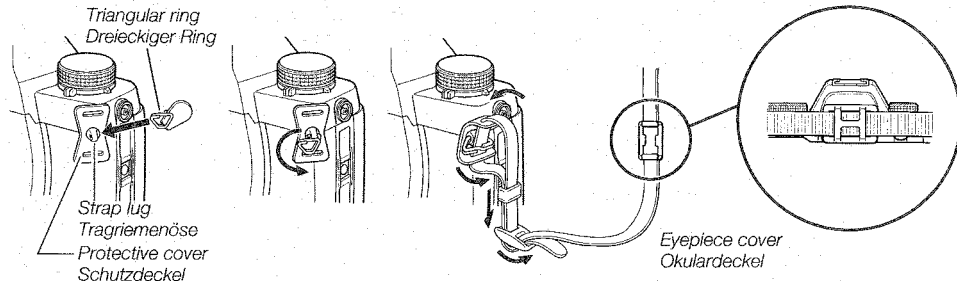

### **Attaching the Eyecup**

Attach the eyecup to the eyepiece as shown in the illustration.

### **Fixation de l'ocillon**

Fixez l'ocillon sur l'oculaire comme indiqué sur l'illustration.

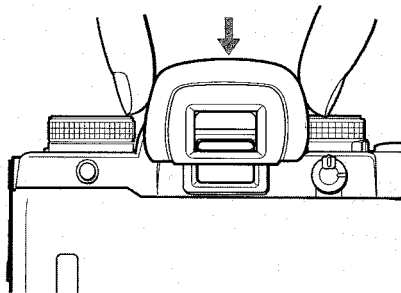

### **Anbringen der Augenmuschel**

Bringen Sie die Augenmuschel wie in der Abbildung gezeigt am Okular an.

### **Colocación del marco del ocular**

Coloque el marco del ocular en el ocular como se muestra en la ilustración.

*Basic Operations Before Shooting*  
*Vorbereitungen vor dem Fotografieren*  
*Etapas de préparation à la prise de vues*  
*Operaciones básicas antes de fotografiar*

## Loading the Batteries

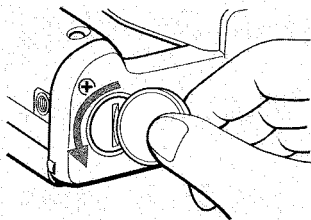

Turn the main switch OFF before loading the batteries.

### **1** Open the battery compartment cover.

Use a coin or the like to turn the battery compartment cover in the direction of the arrow and open it.

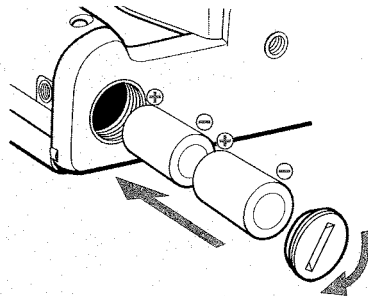

### **2** Insert two 3 V lithium batteries (CR2) in the battery compartment making sure that they are correctly oriented.

- Note that not only does the camera not function it may also be damaged when the batteries are inserted incorrectly.

### **3** Close the cover.

### <Battery Check>



### <Time to replace the batteries>









*Replace the batteries.*

### <Battery Check>

After the batteries are loaded, turn on the camera. The battery voltage is normal if “” (battery warning mark) does not appear in the display panel.

### <Battery Replacement>

You should replace the batteries when “” appears on the display panel. Turn the main switch off, open the battery compartment cover and replace the batteries with new ones.

- Although you can take pictures even after “” appears, you should replace the batteries as soon as possible. If the battery capacity drops below the effective limit, “” on the display panel blinks or goes out and the camera will no longer operate.
- The voltage of some batteries may temporarily decrease causing “” to appear when they are loaded in the camera. If “” appears soon after new batteries are loaded, turn the main switch off and then back on again. If “” does not appear again, you can use the batteries.

### <Battery Precautions>

- Always replace the batteries with new ones of the same type. Do not mix different kinds of batteries or new and old batteries. Always use two new batteries of the same type and brand.
- Generally, battery performance is reduced by cold temperatures. If you are shooting in cold weather, it is advisable to keep the camera warm in a bag or an outfit for protection against cold. The battery reduced by low temperatures will return to normal when you take pictures at an ordinary temperature.
- Before loading the batteries wipe both poles clean with a dry cloth because poor contact may result if they are soiled with sweat or grease.
- If you are going on a long trip, bring new spare batteries with you.
- Do not throw used batteries into fire or try to change or disassemble them because it is dangerous.
- The 3V lithium battery (CR2) cannot be charged by any means.
- Battery should be kept away from children.

### <Batteriehinweise>

- Verwenden Sie immer nur zwei neue Batterien gleichen Typs und gleicher Marke. Mischen Sie keine verschiedenen Sorten oder neue und alte.
- Wenn die Batterien längere Zeit niedrigen Temperaturen (unter 0 °C) ausgesetzt werden, läßt ihre Leistung nach. Bei Kälte bewahren Sie die Kamera am besten unter der Kleidung auf, solange Sie nicht fotografieren. Die Batterieleistung normalisiert sich wieder nach Erwärmung auf normale Temperaturen.
- Wenn die Batteriepole verschmutzt oder oxidiert sind, kann es Kontaktschwierigkeiten geben. Wischen Sie die Pole vor dem Einlegen mit einem trockenen Tuch ab.
- Nehmen Sie Ersatzbatterien mit, wenn Sie länger unterwegs sein werden.
- Batterien sind gefährlich und können explodieren. Leere Batterien dürfen nicht ins Feuer geworfen geladen, kurzgeschlossen oder auseinandergenommen werden.
- Lithium-Batterien sind nicht wieder aufladbar.
- Halten Sie die Batterien außerhalb der Reichweite von Kindern.



## Mounting and Dismounting the Lens

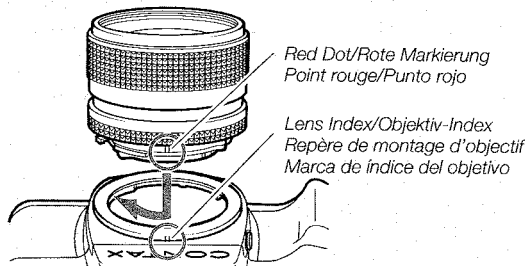

### <Mounting the Lens>

First, remove the camera body cap and the lens rear cap by turning them counter-clockwise. Then, align the red dot on the lens with the lens index on the camera, fit it in and turn it clockwise until it locks with a click.

- If the lens is fitted on the camera body without aligning it with the red dot, levers and other mechanisms will be exposed to excess force leading to damage or failure.

*Lens Release Button  
Objektiventriegelung  
Bouton de déverrouillage d'objectif  
Botón de liberación del objetivo*

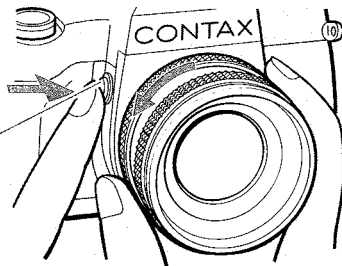

### <Dismounting the Lens>

**While pressing the lens release button, turn the lens counterclockwise as far as it will go and pull it outward toward you. After dismounting the lens from the camera, protect the lens with the rear cap and the camera with the body cap.**

- Do not touch the lens surface or inside the camera when attaching and detaching the lens.
- Avoid direct sunlight when changing the lens with film loaded in the camera.

## Main Switch

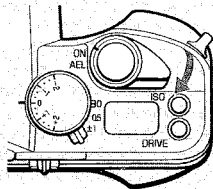

*OFF Position*  
*OFF = ausgeschaltet*  
*Position d'arrêt (OFF)*  
*Posición OFF*

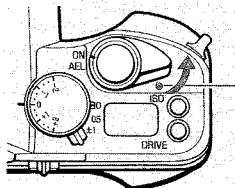

*ON Position*  
*ON = eingeschaltet*  
*Position de marche (ON)*  
*Posición ON*

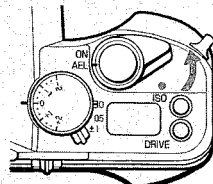

*Red Mark*  
*Roter Punkt*  
*Repère rouge*  
*Marca roja*

*AEL (AE Lock Position)*  
*AEL = Meßwertspeicher*  
*AEL (Verrouillage d'exposition)*  
*AEL (posición de bloqueo de AE)*

**The main switch turns the camera on or off and sets or releases the AE lock.**

- The main switch should be locked at a click position when shooting to prevent it from being shifted by mistake.

### **OFF: Red mark not visible**

When the red mark is not visible, the main switch is off, turning off the camera. If you are not using the camera, turn off the main switch to prevent the shutter from being inadvertently set to on.

### **“ON” mark**

The camera is turned on.

### **“AEL” mark**

The AE lock is useful for shooting with backlighting or continuous shooting of a moving subject at a fixed exposure.

- For details on the AE lock, see page 132.

## Viewfinder Display and Display Panel

**<Viewfinder Display>** (For purposes of explanation, the viewfinder display is shown here with all information displayed; not all items are displayed simultaneously under actual conditions of use.)

Matte Screen

Mattscheibefeld

Dépoli de visée

Pantalla mate

Microprism Collar

Mikroprismenring

Couronne de microprismes

Pantalla microprismática

Horizontal Split-image Spot

Horizontaler Schnittbildindikator

Télémetre à champ coupé horizontal

Punto de imagen de división horizontal

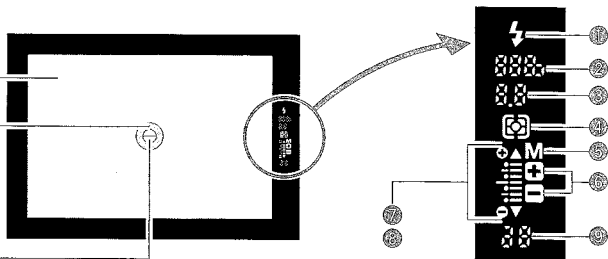

The display in the viewfinder will turn on in the following cases, then turn off automatically after 16 seconds.

- ① When the main switch is turned on.
- ② When the shutter release is depressed halfway while the main switch is on.  
If you switch a button, dial, etc. while the display is on, it will remain on for another 16 seconds.

## <Viewfinder Display>

The viewfinder display is an information intensive finder which displays exposure indicators such as aperture, shutter speed, exposure meter, exposure counter, etc.

### Ⓜ Flash Mark

When using the TLA flash system for taking flash pictures, the flash mark “” will appear as soon as the flash is fully charged. If your subject is correctly exposed, it will blink two seconds after the flash has fired (see pages 146 and 147).

### Ⓜ Shutter Speed

The camera displays the shutter speeds from 1/4000 sec. to 16 sec. “4000” means 1/4000 sec. and “125” means 1/125 sec., and “16” means 16 sec. (see page 90).

### Ⓜ Aperture Value

In the aperture-priority auto exposure (Av) and manual exposure (M) modes, the aperture you have selected is displayed in the viewfinder. In the shutter speed-priority (Tv) and programmed auto exposure (P) modes, the

displayed aperture is the aperture selected by the camera in accordance with the shutter speed you have selected (see page 90).

### Ⓜ Metering Mark

This mark indicates the metering mode and AE lock.

Evaluative metering mode:

The “” mark lights (see page 118).

Center-weighted average light metering mode:

The “” mark lights (see page 118).

Spot-metering mode:

The “” mark lights (see page 120).

Evaluative metering and AE locked mode:

The “” mark blinks.

Center-weighted average light metering and AE locked mode:

The “” mark blinks.

Spot metering and AE locked mode:

The “” mark blinks.

### Ⓜ “M” Mark

This mark indicates that the exposure mode has been set to “M” or “X” (see pages 112 and 162).

### ⑥ Exposure Compensation Mark

When the exposure compensation dial is set anywhere other than to “0”, the “+” or “-” mark will blink (see page 126).

### ⑦ Exposure Warning Mark “▲” “▼”

In the auto exposure mode (“Av”, “Tv”, or “P”), the over “▲” or under “▼” mark indicating deviation from the exposure control range will blink.

### ⑧ Exposure Meter

This meter indicates the following depending on exposure mode.

#### ① Auto exposure modes (“Tv”, “Av”, “P” modes)

Only displayed during evaluative metering when it shows how it differs from the center-weighted average light metering (see page 108).

#### ② Manual exposure “M” or flash exposure “X”

Displays the difference between set exposure value and correct exposure (in selected exposure mode) (see page 112).

#### ③ Bulb exposure

Not displayed

### ⑨ Exposure Counter

The exposure counter shows the number of frames in position for exposure (a number between 00 to 39 or E for any number of 40 and above). It also provides the following functions:

- Displays the remaining time while the self-timer is operating (10 sec. to 00)
- Displays the operation order in the “A.B.C.” mode (automatic exposure compensation for three consecutive frames).
- Displays the end of the film.

**<Display Panel>** (For purposes of explanation, the display panel is shown here with all information displayed; not all items are displayed simultaneously under actual conditions of use.)

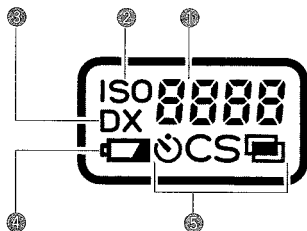

### **<Display Panel>**

#### **1 Exposure Counter/Film Speed**

The exposure counter shows the number of frames in position for exposure. When the ISO button is pressed, it shows the film speed. When DX film is loaded in the camera and the film speed is set to DX, the DX value is displayed. It also has the following functions:

- Displays the remaining time while the self-timer is operating.
- Displays the time that has elapsed on bulb exposure.
- Displays the operation order in the A. B. C. mode.
- Displays set condition for custom functions.
- Displays the end of the film.

### ② ISO Indicator

This indicator will be displayed when the film speed setting is set or viewed.

### ③ DX Mark

“DX” is always displayed for automatic DX code setting.

### ④ Battery Warning Mark “”

Indicates the time to replace the batteries.

### ⑤ Drive Mode Mark

Self-timer mode: “”

Single-frame shooting mode: “S”

Continuous-frame shooting mode: “C”

Multiple-exposure mode: “”

### ② ISO-Anzeige

Diese Anzeige erscheint bei Einstellung und Kontrolle der Filmempfindlichkeit.

### ③ DX-Anzeige

Bei automatischer Einstellung über DX-Code erscheint immer “DX”.

### ④ Batteriewarnsymbol “”

Zeigt an, wann die Batterien gewechselt werden müssen.

### ⑤ Transportfunktions-Symbol

Selbstausröser: “”

Einzelbildbelichtung: “S”

Serienbelichtung: “C”

Mehrfachbelichtungen: “”



## Loading the Film

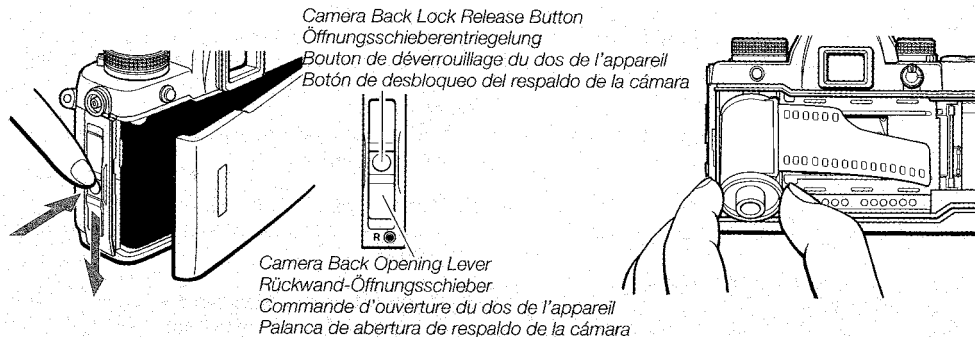

**1** While pressing the lock release button, slide down the camera back opening lever and open the camera back.

- When loading a film, never forget to remove the protective sheet inside the camera.
- Take care not to touch or contaminate the DX contacts and data back contacts.
- Always load and unload films in subdued light.

**2** Insert the film slant-wise into the film chamber with its protruding end downwards.

### **Note on the shutter curtain:**

The shutter curtain is a precision part. Never touch it with your finger or strike it with the film leader. When the film leader lies on the shutter curtain, in particular, never trip the shutter.

Spool/Filmaufwickelspule/Bobine réceptrice/Carrete

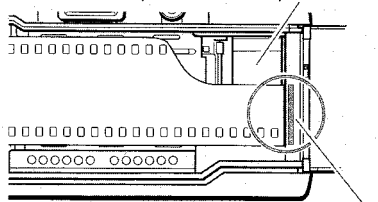

Film Leader mark/Filmanfangs-Markierung  
Repère d'amorce du film/  
Marca de la parte guía de la película

### 3 Pull out the film leader as far as the orange "I" mark and place it on the spool.

Make sure that the film is in contact with the shutter and does not curl outwards (see illustrations below).

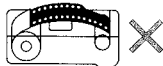
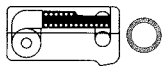

- When too much of the film has been pulled out, rewind excess film back into the cassette.

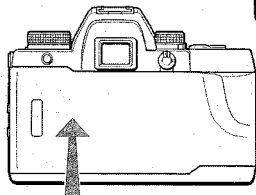

### 4 Make sure the camera back is properly closed.

When the camera back is closed, the film is automatically advanced into position for the first shot and the exposure counter will show "01."

When the exposure counter in the display panel blinks and does not move from "00", the film is not advancing properly. Open the camera back and reload the film properly again.

## Setting the Film Speed

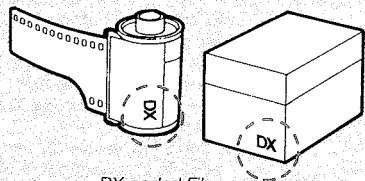

*DX-coded Film*  
*DX-Film*  
*Film à code DX*  
*Película con código DX*

The film speed is automatically set when the main switch is on and “DX” is displayed on the display panel. When using DX-coded film, no adjustment is required. **Be sure to set the film speed manually when “DX” is not shown on the display.**

The film speed can be set in two ways: automatic setting with DX-codes and manual setting.

Display Panel  
LCD-Monitor  
Ecran d'affichage externe  
Panel visualizador

Exposure Counter  
Bildzählwerk  
Compteur de vues  
Contador de exposiciones

DX mark indication  
DX-Anzeige  
Voyant DX  
Indicación de la marca DX



The film speed is automatically set when DX-coded film is used.

Bei Verwendung von DX-Filmen erfolgt die ISO-Einstellung automatisch.

La sensibilité est automatiquement réglée à l'emploi d'un film à code DX.

La sensibilidad de la película se ajusta automáticamente cuando se emplea película con código DX.

### ■ When set to “DX” (automatic speed setting mode)

When DX-coded film is used, the film speed is automatically set. **The film speed range for DX-coded film is ISO 25 to 5000.** The “DX” mark and the film speed is indicated on the film package.

- The film speed is automatically set to ISO 100 when film other than DX-coded film is loaded.

**Display Panel**  
**LCD-Monitor**  
**Ecran d'affichage**  
**externe**  
**Panel visualizador**

*No DX mark displayed*  
*Keine "DX"-Anzeige*  
*Pas de voyant DX affichée*  
*No se visualiza la marca DX*



*The film speed is not set automatically. Set the film speed manually.*

*Die Filmempfindlichkeit muß manuell eingestellt werden.*

*La sensibilité n'est pas réglée automatiquement; ajustez-la manuellement.*

*La sensibilidad de la película o se ajusta automáticamente. Ajuste manualmente la sensibilidad de la película.*

## ■ Manual Setting of the Film Speed

Set the film speed manually when using non-DX film, or when you want to use a film speed other than that of the film.

- You can set the film speed in 1/3 step increments in a range of ISO 6 to 6400.
- A manual film speed setting overrides a DX-coded film speed setting.

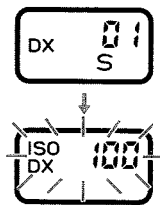

Blinks/Blinkt  
Clignote/Parpadea

ISO Button/ISO-Taste  
Bouton ISO/Botón ISO

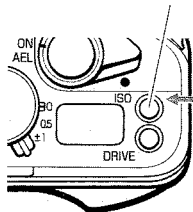

Press until setting starts to blink  
Gedrückt halten, bis der ISO-Wert zu blinken beginnt.  
Appuyez jusqu'au clignotement.  
Presione hasta que el ajuste empiece a parpadear.

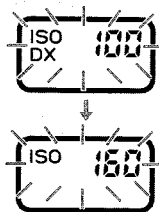

"UP" Button/"UP"-Taste  
Bouton "HAUT"/Botón "UP"

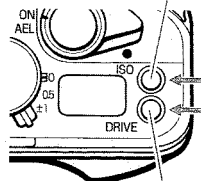

"DOWN" Button/ "DOWN"-Taste  
Bouton "BAS"/Botón "DOWN"

**1** Turn the main switch on and hold down the ISO button (about 2 sec.) until the film speed setting starts blinking.

Take your finger off the button when the blinking starts.

**2** Press the "UP" button (ISO button) or "DOWN" button (Drive Mode button) so that "DX" or the desired film speed setting appears on the display panel.

The film speed changes in 1/3 steps each time the buttons are pressed.

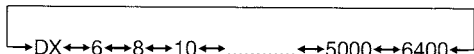

(The film speed changes continuously when the buttons are held down.)

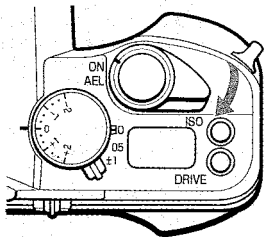

ISO Button/ISO-Taste  
Bouton ISO/Botón ISO

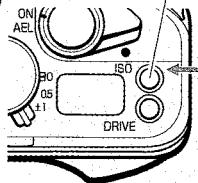

### 3 Now turn main switch off to complete film speed setting.

- The film speed setting can also be completed by depressing the shutter release halfway or by leaving the camera idle for 16 seconds.
- When the film speed setting is made, the exposure counter reading replaces the film speed value.

The set film speed is stored until it is reset.

### <Checking the Film Speed>

Turn the main switch on and press the ISO button to display the film speed setting on the display panel for about 16 seconds. "DX" and the film speed is displayed in DX mode.

## Exposure Mode Selector Lever

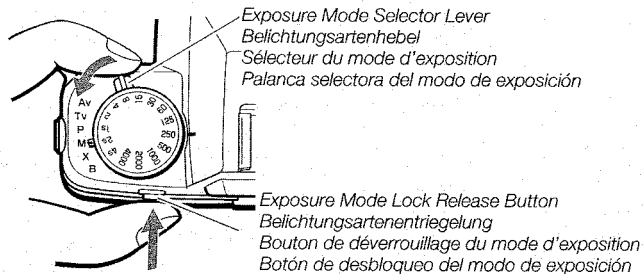

Use this lever to change exposure modes.  
**Press in the exposure mode lock release button and turn the exposure mode selector lever to set the exposure mode index to desired position.**

For details on exposure modes, see pages 92 to 114.



## Drive Mode Button

Lights  
Leuchtet  
S'allume  
Se enciende



Blinks  
Blinkt  
Clignote  
Parpadea

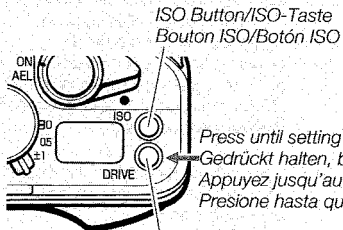

Press until setting starts to blink  
Gedrückt halten, bis die Anzeige zu blinken beginnt.  
Appuyez jusqu'au clignotement  
Presione hasta que empiece a parpadear

Drive Mode Button/Filmtransporttaste  
Bouton de mode d'entraînement/Botón del modo motorizado

The drive mode button allows you to select one of the following four modes: “S” single-frame shooting, “C” continuous shooting mode, “☺” self-timer shooting and “” multiple exposure modes.

**1 Turn the main switch on and hold down the drive mode button until the drive mode setting starts to blink (about 2 seconds).**

Take your finger off the button when the blinking starts.

The drive modes will change as shown below each time the button is pressed.  
 Bei jeder Betätigung der Taste wechselt die Anzeige der Transportfunktion in der Reihenfolge der Abbildung.  
 Le mode d'entraînement change dans l'ordre suivant à chaque pression sur le bouton.  
 Los modos motorizados cambian como se muestra abajo cada vez que se presiona el botón.

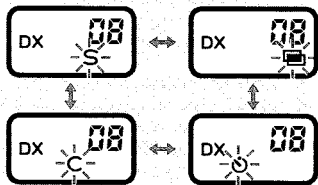

**2** Press the drive mode button (DOWN button) or the ISO button (UP button) to set the desired drive mode.

**3** Press the shutter release halfway to light the drive mode indication. This action completes the drive mode setting.

- The drive mode can also be set by operating the main switch, changing exposure mode or waiting 8 seconds until the blinking is replaced by steady lighting.
- In selftimer mode “☺” or multiple exposure mode “☑”, the respective indication blinks.
- When the main switch is set to OFF while “☺” or “☑” mode has been set, the mode is canceled. When the main switch is turned on later, the camera starts in “S” drive mode.

### **“S” Single-frame shooting mode**

Each time the shutter release is depressed, one frame is exposed and the film is advanced for the next shot, then stops.

### **“C” Continuous shooting mode**

While the shutter release is depressed, the camera continues to take pictures at a maximum speed of about 3 frames a second. (The shooting speed differs with the shutter speed, film speed, whether or not dates are imprinted between frames, battery condition, etc.)

### **“” Self-timer shooting mode**

Use this mode for self-timer shooting. For details, see page 170.

### **“” Multiple exposure shooting**

Use this mode for multiple exposure shooting. For details, see page 164.

### **“S” Einzelbildbelichtung**

Mit jedem Druck auf den Auslöser wird belichtet und der Film anschließend zur nächsten Aufnahme transportiert.

### **“C” Serienbelichtung**

Solange Sie den Auslöser gedrückt halten, belichtet die Kamera ein Bild nach dem anderen mit einer maximalen Frequenz von ca. 3 Bildern pro Sekunde. (Eine lange Verschlusszeit, geringe Filmempfindlichkeit, Dateneinbelichtung zwischen die Aufnahmen, Batteriezustand usw. verringern die maximale Bildfrequenz.)

### **“” Selbstauslöser**

Mit Selbstauslöser erfolgt die Belichtung 10 Sekunden nach Drücken des Auslösers. Einzelheiten hierzu finden Sie auf S. 171.

### **“” Mehrfachbelichtungen**

Wenn Sie mehrere Belichtungen zu einem Bild kombinieren wollen, wählen Sie diese Einstellung. Einzelheiten hierzu finden Sie auf S. 165.

## Shutter Speed Dial

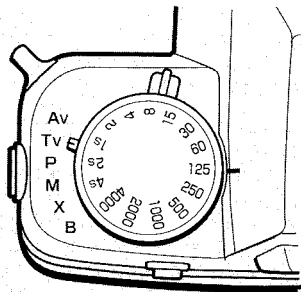





Use the shutter speed dial to adjust the shutter speed. It can be used in the shutter-speed-priority auto exposure ("Tv") and manual exposure ("M") modes.

Shutter speeds can be set in 1 step increments from 4s (4 sec.) to 4000 (1/4000 sec.).

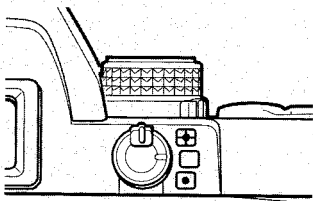
- The shutter speed must be fixed at a click position when shooting.

## Metering Mode Selector Lever



This camera provides three metering methods: “” evaluative metering, “” center-weighted average light metering and “” spot metering.

For information on the different metering methods, see page 116.

## Focusing the Lens

*Focusing screens can also be exchanged. For details, see page 226.*



*Subject in Sharp Focus/Motiv fokussiert  
Sujet net/Motivo nitidamente enfocado*

The FU-4 focusing screen (horizontal split-image spot/micropism type) comes with the camera as standard equipment. The subject is focused using the horizontal split-image spot in the center, on the micropism around it, and on the surrounding matte area.



*Subject out of Focus/Motiv unscharf  
Sujet flou/Motivo desenfocado*

### **<Horizontal Split Image Spot>**

While looking through the viewfinder, turn the distance ring until the upper and lower segments of the image coincide. When the subject is not focused, the two segments will not coincide.

### <Microprism Collar and Matte Screen>

Turn the distance ring until the image on the microprism collar or matte screen appears sharp. If the subject is not in sharp focus, the image on the microprism collar will appear grainy and that on the matte screen blurred.

- When using a slow lens or taking close-ups with a high magnification, focusing may be difficult. In such cases, use the matte screen to focus.
- If you are nearsighted or farsighted and find focusing difficult, acquire an optional FL diopter lens. Eight types are available from  $-5D$  to  $+3D$  that can be attached to the viewfinder eyepiece (see page 234).

### <Mikroprismenring und Mattscheibe>

Drehen Sie am Fokussiering des Objektivs, bis das Motiv im Mikroprismenring oder auf der Mattscheibe scharf erscheint. Wenn die Schärfe nicht stimmt, erscheint das Bild in den Mikroprismen gerastert oder auf der Mattscheibe unscharf.

- Mit lichtschwachen Objektiven und bei extremen Nahaufnahmen können Schnittbild und Mikroprismen abdunkeln. Fokussieren Sie dann mit Hilfe der Mattscheibe.
- Wenn Sie weit- oder kurzsichtig sind und die Fokussierung dadurch erschwert wird, hilft eine als Zubehör erhältliche Okularkorrekturlinse Typ FL. Diese Linse ist in acht Ausführungen mit einem Korrekturbereich von  $-5$  bis  $+3$  Dioptrien erhältlich und wird am Sucherokular befestigt (siehe S. 235).

## Holding the Camera

- ① *Keep your elbows tucked in to steady the camera.*
- ② *Hold your breath as you prepare to take the picture.*
- ③ *Gently depress the shutter release without straining yourself.*



To take sharp pictures, the camera must be held steady. Blurred pictures are most often caused by camera shake.

The camera can be held not only in the horizontal position, but also in the vertical position depending on the subject. In any case, find the camera holding techniques that suit you best. You can also use buildings and trees for support.



## Rewinding the Film

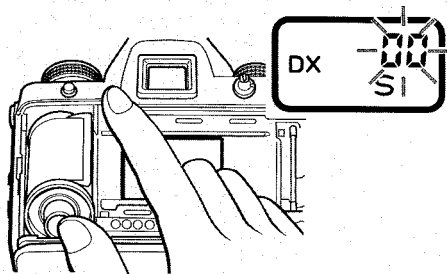

**After the last frame is exposed, the camera will automatically rewind the film.**

While the film is rewinding, the counter reading decreases continuously. When rewinding completes, the motor will stop and "00" will blink on the exposure counter.

**Check that the motor has stopped and that "00" blinks on the exposure counter before opening the camera back and removing the film.**

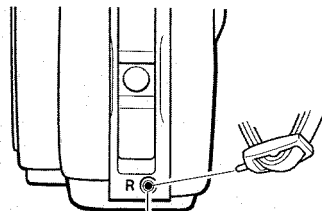

*Manual Rewind Button  
Taste für vorzeitige Filmrückspulung  
Bouton de rembobinage manuel  
Botón de rebobinado manual*

Use the manual rewind button to remove a film in mid-roll. Press the button using the front end of the supplied strap stopper. **(Do not use a needle or other pointed object.)**

- Remove the film in subdued lighting.
- Be sure to unload the film after it has been rewound. After the film has been rewound, the camera will not operate unless the camera back is once opened.
- Films that have been exposed should be developed as soon as possible.
- When more frames than the number normally provided by the film is shot, the last frame may be cut in processing.
- Entnehmen Sie den Film immer im Schatten.
- Nehmen Sie den Film nach dem Rückspulen aus der Kamera. Nach dem Rückspulen des Films funktioniert die Kamera erst wieder, wenn die Rückwand einmal geöffnet wurde.
- Wenn eine größere Anzahl von Bildern belichtet wurde, als normalerweise auf dem eingelegten Film zur Verfügung stehen, kann es sein, daß das letzte Bild bei der Entwicklung beschnitten wird.
- Lassen Sie den belichteten Film baldmöglichst entwickeln.

## Shutter Speed and Aperture Indicators

The shutter speed and the aperture are indicated in the following manner.

- The shutter speed is indicated in the range of 4000 (1/4000 sec.) to 16 (16 sec.). When the exposure mode is "Av" or "P", the shutter speed coupled with the aperture is shown in 1/2 steps. In "Tv" or "M" modes, the set value is displayed. When set to "X", the shutter speed of "125" is displayed. When set to "B", the shutter speed is displayed as "bLb."
- The aperture is indicated in 1/2 steps in the aperture range of the used lens. However, when the aperture is operated in less than 1/2 steps, an approximate value will be displayed. For example, an aperture of F3.3 is indicated as "3.5".

Shutter Speed Verschlußzeit Vitesse d'obturation Velocidad del obturador			Aperture Blende Diaphragme Abertura	
"Av" or "P" "Av" oder "P" "Av" ou "P" "Av" o "P"		"Tv" or "M" "Tv" oder "M" "Tv" ou "M" "Tv" o "M"	All Modes Alle Belichtungsarten Tous modes Todos los modos	
4000	2800	4000	32	27
2000	1400	2000	22	19
1000	700	1000	16	13
500	350	500	11	9.5
250	180	250	8.0	6.5
125	90	125	5.6	4.5
60	45	60	4.0	3.5
30	20	30	2.8	2.4
15	10	15	2.0	1.7
8	6	8	1.4	1.2
4	3	4		
2	0"7	2		
1"	1"4	1"		
2"	2"8	2"		
4"	5"6	4"		
8"	11"			
16"				

# Taking Pictures ● *Selecting the Exposure Mode* ●

You can choose the following exposure modes depending on your shooting object and application.

## **Av: Aperture-priority Auto Exposure**

When choosing your desired aperture, the camera will automatically select the shutter speed suited for it to provide correct exposure. This mode is useful for taking pictures by utilizing the lens depth of field.

## **Tv: Shutter-speed-priority Auto Exposure (with MM type lenses only)**

When choosing your desired shutter speed, the camera will automatically select the aperture suited for it to provide correct exposure. This mode is useful for taking fast moving objects.

## **P: Programmed Auto Exposure (with MM type lenses only)**

In this mode, the camera will automatically select the optimum combination of aperture and shutter speed on a preset program in accordance with the brightness of the object. Because it is not necessary to set exposure, you can concentrate on composing your picture and choosing the best shooting moment.

## **M: Manual Exposure**

In this mode, you can choose the aperture and shutter speed as desired. Intentional over-or underexposure is also easy.

## **X: Flash Photography**

This mode is for use with an ordinary flash unit having only an X-contact but no dedicated flash linked contact. A shutter speed of 1/125 is used. For details, see "Taking Pictures Using X-contact Flash Units Other than TLA Flash Unit" on page 162.

## **B: Bulb Exposure**

This mode can be used for taking night scenes or pictures of the sky at night which require long exposure.

- If an AE lens is mounted on the camera, you cannot take pictures in the "Tv" or "P" mode. Even if it is been set to the "Tv" or "P" mode, it will nevertheless operate in the "Av" mode.
- If no lens is mounted on the camera, the exposure mode will automatically switch to the "Av" mode even if it has been set to the "Tv" or "P" mode.

## Aperture-priority Auto Exposure [Av]

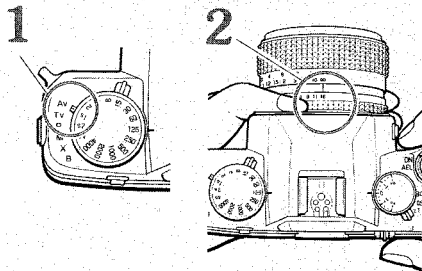

**1** Set the exposure mode selector lever to "Av."

**2** Set the aperture and shoot.

When setting the aperture with the lens aperture ring, the camera will automatically set a suitable shutter speed.

The set aperture and the automatically set shutter speed light in the viewfinder.

It does not matter where the shutter speed dial is set.

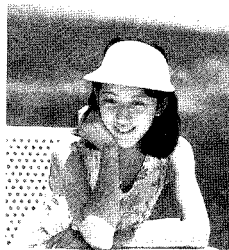

*Example 1: F1.4*

*Beispiel 1: f/1,4*

*Exemple 1: F1,4*

*Ejemplo 1: F1,4*

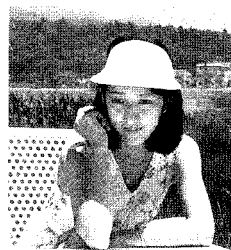

*Example 2: F16*

*Beispiel 2: f/16*

*Exemple 2: F16*

*Ejemplo 2: F16*

**Example 1:** When a large aperture is used, the depth of field (the length of the zone on either side of the subject that are in focus) decreases. This characteristic can be used to focus attention on the subject by blurring the background.

**Example 2:** Small apertures produce greater depth-of-field. This is ideal when you want both the subject and the background in focus.

※Make aperture adjustments to suit the subject and your preferences. For more information on depth-of-field, see page 194.

## Shutter-speed-priority Auto Exposure [Tv] (with MM type lenses only)

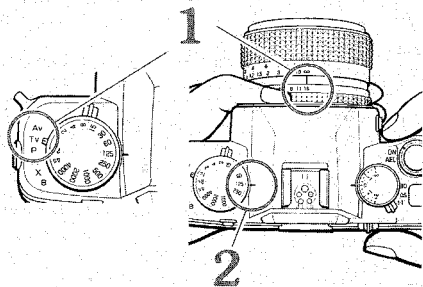

**1** Set the lens aperture to the minimum aperture (green) and set the exposure mode selector lever to "Tv."

The minimum aperture on the aperture ring of MM type lenses is marked in green to show that you should set the lens to it in the programmed auto exposure and shutter-speed-priority auto exposure modes.

**2** Set the shutter speed and shoot  
When the shutter speed is set by turning the shutter speed dial, the camera will automatically set the aperture suited for it.



**Example 1:** Fast shutter speed

**Beispiel 1:** Kurze Verschlußzeit

**Exemple 1:** Vitesse d'obturation rapide

**Ejemplo 1:** Velocidad del obturador rápida



**Example 2:** Slow shutter speed

**Beispiel 2:** Lange Verschlußzeit

**Example 2:** Vitesse d'obturation lente

**Ejemplo 2:** Velocidad del obturador lenta

The shutter speed you set and the automatically selected aperture light in the viewfinder.

**Example 1:** Use a fast shutter speed to "freeze" moving subjects.

**Example 2:** Use a slow shutter speed to express movement, for example, of flowing water.

● To prevent camera shake with slow shutter speeds, use a tripod.

## <Shutter Speed Shift and Warning in the Shutter-Speed-Priority Auto Exposure Mode>

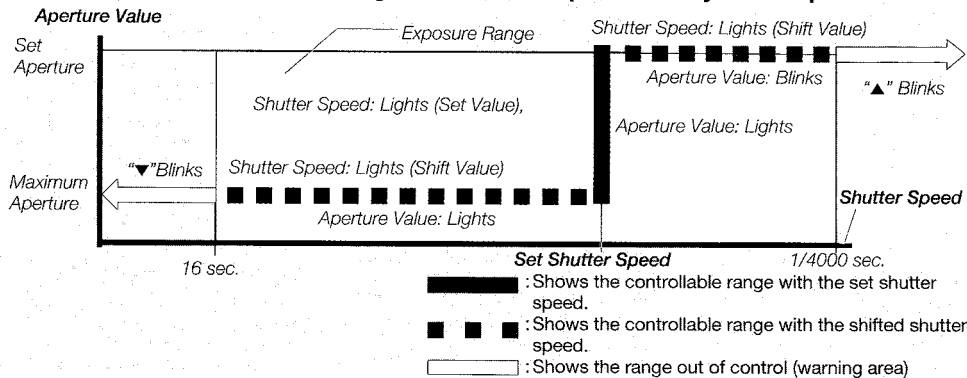

In the "Tv" mode, the shutter speed you have selected cannot provide correct exposure because the aperture suited for it is beyond the lens aperture range, the camera will then automatically shift the shutter speed to always provide correct exposure. The shifted shutter speed is displayed. The controllable range of shutter speeds on automatic setting is from 16 to 1/4000 seconds.

- When the correct shutter speed is faster than that you have set, the aperture will blink. Make sure the lens is set at minimum aperture.
- When an MM type lens is set to an aperture that is not its minimum aperture, the camera will automatically choose an appropriate aperture between the maximum aperture and the aperture being set.

## Programmed Auto Exposure [P] (with MM type lenses only)

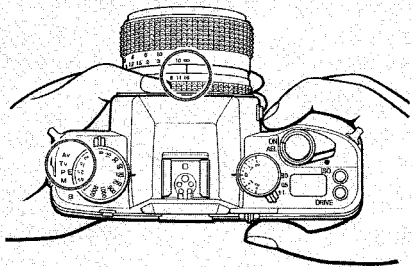

**1** Set the lens to its minimum aperture (in green) and set the exposure mode selector lever to "P."

**2** Compose your picture and shoot.

The camera will automatically select the optimum combination of aperture and shutter speed to suit your subject, and the selected aperture and shutter speed will be displayed in the viewfinder.

### <Programmed Auto Control Diagram>

(with F1.4 lens, using F16 and ISO 100)

The combination of aperture and shutter speed which can be set in the programmed auto exposure mode are shown in the diagram.

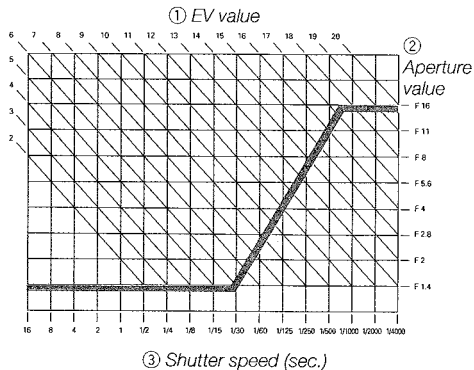

- An aperture value between the set aperture and full opening is automatically set if the MM lens is not set to its minimum aperture.



## Precautions on Auto Exposure (“Av”, “Tv”, “P”)

*Blinks  
Blinkt  
Clignote  
Parpadea*



*Overexposure warning  
Überbelichtungswarnung  
Signal de surexposition  
Aviso de sobreexposición*

*Blinks  
Blinkt  
Clignote  
Parpadea*



*Underexposure warning  
Unterbelichtungswarnung  
Signal de sous-exposition  
Aviso de subexposición*

### <Over/Underexposure Warning in Auto Exposure>

#### Overexposure Warning:

A blinking overexposure mark “▲” indicates overexposure. Because the subject is too bright, readjust the aperture so that the “▲” mark goes off. It is also possible to reduce the light intensity with an optional ND filter.

#### Underexposure Warning:

A blinking underexposure mark “▼” indicates underexposure. Because the subject is too dark, use additional light to brighten up the subject or change the aperture so that the “▼” mark goes off. Also, a dedicated flash unit will let you take correctly exposed pictures.

- Even when an over-or underexposure warning appears, you can still take the picture by pressing the shutter release.



*Exposure difference is 0.5 EV under  
Belichtungsdifferenz beträgt -0,5 LW.  
Différence de 0,5 IL en sous-exposition  
La diferencia de exposición es de 0,5 EV  
insuficiente*



*No difference  
Keine Differenz  
Pas de différence  
Sin diferencia*



*Difference is 2.0 EV or more over  
Belichtungsdifferenz beträgt +2,0 LW.  
Différence de 2,0 IL en surexposition  
La diferencia es de 2,0 EV o más en  
exceso*

### <Exposure Meter Indication in Evaluative Metering>

**In the evaluative metering mode, the exposure meter lights and indicates the difference between evaluative metering and center-weighted average light metering.**

When only the center bar is displayed, there is no difference between evaluative metering and center-weighted average light metering. An additional bar lights for each 0.5 EV exposure change. When the difference is 2.0 EV or greater, the bar and “▲” will light.

- When the “▲” or “▼” lights, the camera warns against under- or overexposure. Then adjust the exposure according to the instructions given on page 106.
- In center-weighted average light “[ ]” and spot “[ ]” metering modes, the exposure meter is not displayed.
- For information on the different metering modes, see page 116.

### <Cautions on the Use of Accessories>

When using a lens with a maximum aperture slower than F5.6 or an accessory with which the automatic diaphragm of the lens does not operate (auto bellows PC, microscope adapter, extension tube 7.5 mm, reverse ring, etc.), note the following:

- ① Though the aperture displayed in the viewfinder is fixed at "1.4", the camera light metering system will operate properly.
- ② You cannot take pictures in the shutter-speed-priority (Tv) or programmed auto exposure (P) mode. Choose the aperture-priority exposure (Av) or manual exposure (M) when using these accessories.

### <Hinweise zum Gebrauch von Zubehör>

Wenn Sie ein Objektiv geringerer Lichtstärke als f/5,6 oder Zubehör ohne automatische Blendenmechanik (Auto-Balgen PC, Mikroskop-Adapter, Zwischenring 7,5 mm, Umkehring usw.) verwenden, beachten Sie bitte folgendes:

- ① Auch wenn die Blendenanzeige im Sucher immer "1.4" anzeigt, funktioniert das Belichtungsmeßsystem der Kamera richtig.
- ② Sie können nicht mit Blenden- (Tv) oder Programmautomatik (P) fotografieren. Benutzen Sie bei Gebrauch von derartigem Zubehör die Zeitautomatik (Av) oder die manuelle Nachführmessung (M).

## Manual Exposure [M]

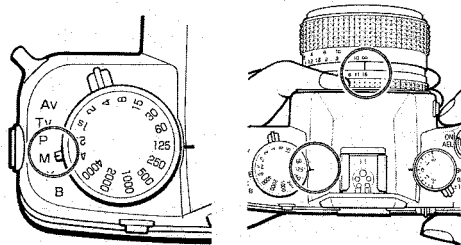

**1** Set the exposure mode selector lever to "M".

**2** Set the shutter speed and aperture and shoot.

Set the shutter speed with the shutter speed dial and aperture with the aperture ring.

The selected shutter speed and aperture value are displayed in the viewfinder.

The exposure meter shows the difference between suitable exposure in the manual exposure mode and the correct exposure value in the set metering mode.

*Exposure Meter Example  
Beispiel der Anzeige der Belichtungsskala  
Exemple d'indication du posemètre  
Ejemplo del medidor de la exposición*



*1 EV Overexposure  
Überbelichtung um 1 LW  
Surexposition 1 IL  
Sobreexposición de 1 EV*

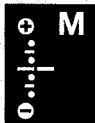

*Correct Exposure  
Richtige Belichtung  
Exposition correcte  
Exposición correcta*



*2 EV or Greater Underexposure  
Unterbelichtung um 2 LW oder mehr  
Sous-exposition 2 IL ou plus  
Subexposición de 2 EV o mayor*

Set the shutter speed dial or the aperture ring to obtain correct exposure.

## Bulb Exposure [B]

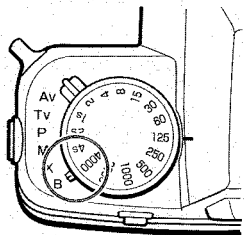

**1** Set the exposure mode selector lever to "B".

**2** Set the aperture and shoot.

As long as the shutter release is depressed, the shutter will remain open to expose the film.

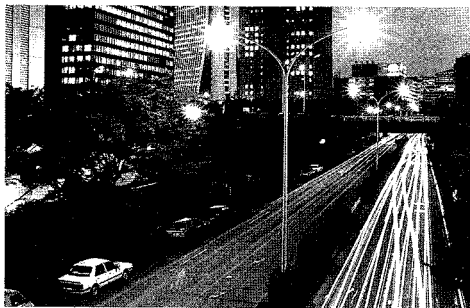

- Mount the camera on a tripod or a stable base to prevent camera shake and trip the shutter with Cable Switch L (optional accessory).
- While the film is exposed in the bulb exposure mode, the exposure counter in the display panel will indicate elapsed time during bulb exposure. It will count from "0'00" to "9'59" (9 minutes 59 seconds), then repeat the same cycle.
- During exposure all the indicators in the viewfinder disappear.

### Miscellaneous Shooting Techniques

### Verschiedene Auf- nahmetechniken

### Techniques diverses de prise de vues

### Otras técnicas fotográficas

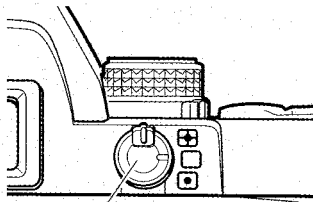

*Metering Mode Selector Lever  
Meßartenhebel  
Sélecteur du mode de mesure  
Palanca selectora del modo de medición*

This camera provides three metering methods: evaluative, center-weighted average light and spot metering.

You can choose the desired method with the metering mode selector lever. Select the metering method that best suits the shooting conditions and your shooting requirements for optimum effect.

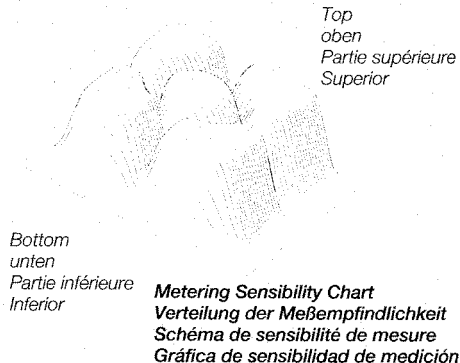
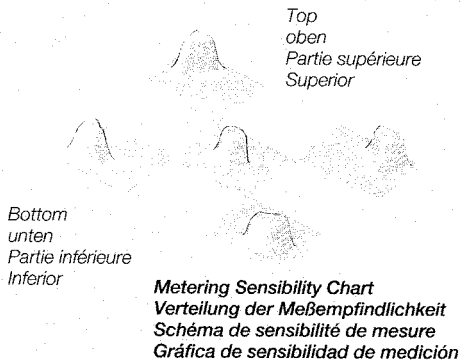

### <Evaluative Metering> “” mark

As shown in the illustration, the evaluative metering method divides the scene into 5 segments and obtains independent metering data from each segment to determine optimum exposure depending on the condition of the subject. **Thus evaluative metering handles not only normal shooting conditions but can automatically compensate for backlit subjects leaving you free to compose the picture.**

### <Center-Weighted Average Light Metering> “”

In this method, the camera measures the light intensity with emphasis on the subject in the center of the viewfinder and also takes the brightness in the surrounding area into account to determine the exposure value. **Because it accommodates fluctuations of light, it is suited for ordinary and fast-moving subjects.**

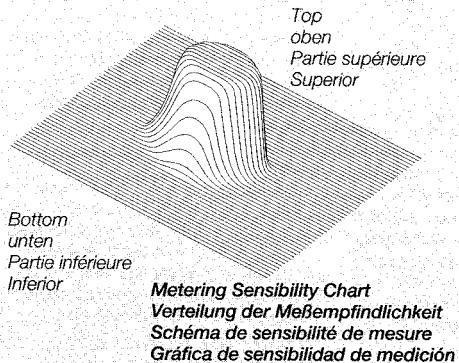

Due to the metering characteristics of this camera, when using a lens with a maximum exposure slower than F5.6 or the Mutar or close-up accessories (Auto Bellows PC, microscope adapter, auto extension tube, reverse ring, etc.) with actual exposure slower than F5.6 may cause metering error in spot metering. Under these conditions, use the center-weighted average light metering method.

### <Spot Metering> “☐”

In this method, the camera measures only the brightness of the subject in the center of the viewfinder (microprism area) to determine the exposure value. Its applicable area is within the outer circle of the center of the viewfinder. It is suited for backlit subjects, **stage scenes in which the main subject is spotlighted, or when there is an extreme difference between the subject and background.**



## <Metering Range>

This chart shows the relationship of the aperture, shutter speed and EV value, and you can check the metering range of your lens on it. If you are shooting with an ISO 100 film and F1.4 lens in the center-weighted average light metering mode, for example, first find "100" on the ISO column in the Lens Aperture table and locate "1.4" and "16" in this row (the minimum aperture of the Planar T\* 50 mm is F16). Then, follow the corresponding oblique lines and find their intersecting points with the vertical line (EV) and horizontal line (shutter speed). This represents the limits of the metering range of an F1.4 lens which is EV "2" to EV "20".

\* The exposure value (EV) shows the coupling range of an exposure meter and represents the shutter speed and aperture combinations that yield the same exposure effect in a given lightning condition. For example, EV 13 in the chart shows that you can take the same exposure at both F16, 1/30 sec. and F8, 1/125 sec.

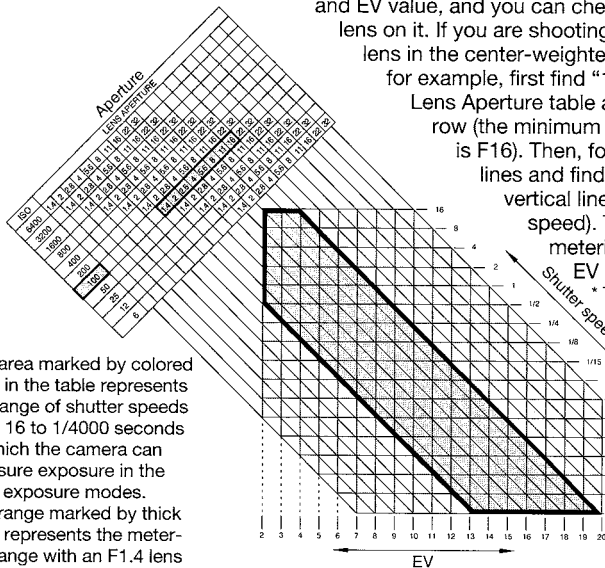

The area marked by colored lines in the table represents the range of shutter speeds from 16 to 1/4000 seconds in which the camera can measure exposure in the auto exposure modes.

The range marked by thick lines represents the metering range with an F1.4 lens and ISO 100 film.

## Exposure Compensation

If there is a great difference in brightness between the subject and its background, the subject will not be correctly exposed. In this case, use exposure compensation. Exposure compensation can also be used for intentional over- and underexposure. There are three methods:

### <1. Using the Exposure Compensation Dial>

Normally, the exposure compensation dial is set to "0" in the aperture-priority (Av), shutter-speed-priority (Tv) or programmed auto exposure (P) and manual exposure (M) modes. To compensate exposure, turn and set the dial so that your desired compensating value comes opposite the index mark. It can be set in 1/3-EV increments within a range of +2 EV to -2 EV. When the exposure compensation dial is set anywhere except "0", the "+" or "-" mark will blink in the viewfinder, indicating that the exposure compensation is in effect.

*Exposure Compensation Dial  
Belichtungskorrektur-Index  
Barillet de correction d'exposition  
Aro de compensación de la exposición*

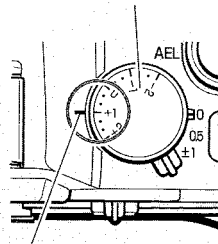

*Exposure Compensation Index  
Belichtungskorrekturring  
Index de correction d'exposition  
Índice de compensación de la exposición*

*Blinks  
Blinkt  
Clignote  
Parpadea*



Exposure Mode	Exposure Correction
Aperture-priority auto exposure mode (Av)	Shutter speed
Shutter-speed priority auto exposure mode (Tv)	Aperture
Programmed auto exposure mode (P)	Aperture and shutter speed

Belichtungsart	Korrektur von
Zeitautomatik (Av)	Verschlußzeit
Blendenautomatik (Tv)	Blende
Programmautomatik (P)	Blende und Verschlußzeit

- In the manual exposure mode (M), exposure cannot be corrected using exposure compensation. However, the exposure meter shows the difference between the set value and “appropriate” exposure. Thus to compensate exposure, use the shutter speed dial or aperture ring to set the desired difference (exposure compensation) before shooting.
- After taking pictures with exposure compensation, be sure to return the dial to “0”.

- Bei manueller Belichtungseinstellung kann die Belichtung nicht korrigiert werden. Die Belichtungsskala zeigt jedoch die Differenz zwischen der eingestellten Belichtung und dem “richtigen” Wert. Um dafür einen Ausgleich zu schaffen, können Sie vor dem Auslösen die Verschlußzeit- oder Blendeneinstellung ändern, um die gewünschte Differenz (Belichtungskorrektur) einzustellen.
- Vergessen Sie nicht, nach Aufnahmen mit Belichtungskorrektur den Ring wieder auf “0” zu stellen.



(No compensation)  
(keine Belichtungskorrektur)  
(Pas de correction)  
(Sin compensación)

(+ compensation)  
(positiver Korrekturfaktor)  
(Correction +)  
(Compensación +)



(- compensation)  
(negativer Korrekturfaktor)  
(Correction -)  
(Compensación -)



### ■ Backlighting Subjects

#### Exposure compensation of “+1/3” to “+2”

When shooting the subject against the light, under a bright sky, on an ocean beach, in front of a window, and so on, where the greater part of your picture is occupied by a bright background, the subject will be under-exposed and turn out dark like a silhouette when it is taken on center-weighted average light metering. In such cases, use exposure compensation of +1/3 to +2 to give more exposure.

### ■ Spotlit Subjects

#### Exposure compensation of “-1/3” to “-2”

When shooting a spotlit subject where a dark background predominates in the scene, the subject will be overexposed and turn out light when it is taken using center-weighted average light metering. In such cases, use an exposure compensation of -1/3 to -2 to reduce the amount of light on it.

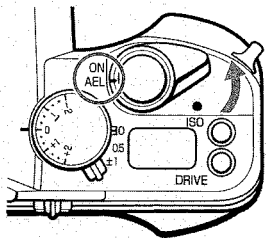

## <2. Using the AE Lock>

The AE lock is used for storing the exposure value (combination of shutter speed and aperture) of the subject in memory during auto exposure. It is used when you shoot the backlit subject or when you make continuous shooting of a moving subject at a fixed exposure. When the main switch is set to "AEL", the exposure value at that time will be stored in the camera memory so that you can trip the shutter with the same exposure value, unaffected by changes in brightness on the background.

**1** First, face the central part of the viewfinder toward your subject then switch the main switch from "ON" to "AEL." The exposure will thus be locked.

To measure exposure in a narrow area and lock it, set the metering mode selector lever for spot metering and use the AE lock.

- The metering mark in the viewfinder blinks during AE lock.
- Set the main switch to "AEL" when the display in the viewfinder lights.

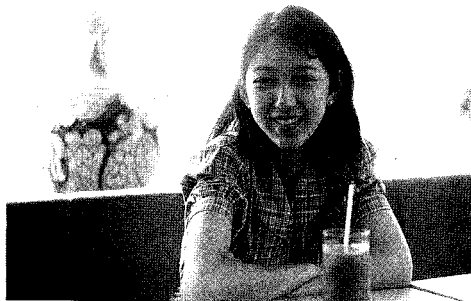

## 2 Recompose your subject and shoot.

- The exposure value will remain in memory while the AE lock is activated, but the display will turn off after 16 seconds to save battery power.

- In the continuous-shooting modes (drive mode “C”), you can take pictures in succession with the same exposure value, unaffected by changes in brightness on the background, if you have locked the exposure.
- This camera stores in memory the exposure value in a combination of shutter speed and aperture. For example, if the aperture is changed in the “Av” mode after the AE lock is activated, the shutter speed will follow to maintain the same exposure value.

- When changing the exposure compensation value in AE locked mode, exposure is made as follows:

Exposure mode	Exposure Correction
Aperture-priority auto exposure mode (Av)	Shutter speed
Shutter-speed-priority auto exposure mode (Tv)	Aperture
Programmed auto exposure mode (P)	Aperture and shutter speed

### <3. Using the A.B.C. Mode (Automatic Exposure Compensation for 3 Consecutive Frames)>

This mode allows you to take pictures automatically in three different steps of exposure: standard, overexposure and underexposure. Even when taking pictures under fluctuating exposure conditions, you can easily capture your subject without worrying about exposure settings. All you have to do is to press the shutter release.

\* A.B.C. is an acronym of "Automatic Bracketing Control".

- Wenn Sie die Belichtungskorrektur bei aktiviertem Meßwertspeicher ändern, erfolgt die Belichtung folgendermaßen:

Belichtungsart	Korrektur von
Zeitautomatik (Av)	Verschlußzeit
Blendenautomatik (Tv)	Blende
Programmautomatik (P)	Blende und Verschlußzeit

### <3. Belichtungsreihenautomatik (3 Fotos mit abgestuft unterschiedlicher Belichtung)>

Damit können Sie automatisch eine Serie von drei Aufnahmen hintereinander mit abgestufter Belichtung machen: richtig, über- und unterbelichtet. So erhalten Sie auf einen Auslöserdruck mit größter Sicherheit auch unter schwierigen Lichtverhältnissen optimal belichtete Fotos.

\* A.B.C. steht für "Automatic Bracketing Control".

In the A.B.C mode, the shutter speed or aperture is adjusted for automatic exposure compensation.

Exposure Mode	Controlled Item
Aperture-priority auto exposure mode (Av)	Shutter speed
Shutter-speed-priority auto exposure mode (Tv)	Aperture (The shutter speed is controlled automatically when the aperture controllable range is exceeded.)
Programmed auto exposure mode (P)	Shutter speed
Manual (M)	Shutter speed

Die Belichtungsreihenautomatik verändert Verschußzeit oder Blende.

Belichtungsart	Veränderung von
Zeitautomatik (Av)	Verschußzeit
Blendenautomatik (Tv)	Blende (Verschußzeit nur bei nicht ausreichendem Blendenbereich)
Programmautomatik (P)	Verschußzeit
Manuelle Nachführmessung (M)	Verschußzeit



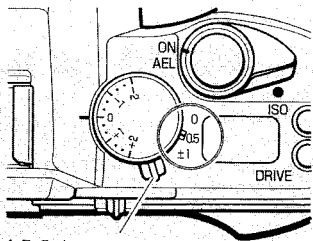

A.B.C. Lever  
A.B.C.-Hebel  
Levier A.B.C.  
Palanca de A.B.C.

**1** Move the A.B.C. lever to set the compensation value. The camera will switch to the A.B.C. mode. Two compensation values are available:  $\pm 0.5$  EV and  $\pm 1$  EV.

- When the exposure compensation dial is set to a position other than "0", the A.B.C. mode is established on the basis of the compensation value being set.
- Metering takes place during each exposure and the measured value is compensated for. When shooting under conditions unaffected by changes in ambient brightness, use the AE lock in the A.B.C. mode.
- After taking pictures in the A.B.C. mode, be sure to return the A.B.C. lever to "0."
- Flash pictures cannot be taken in the A.B.C. mode.

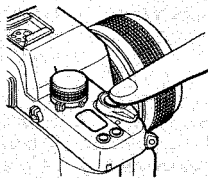
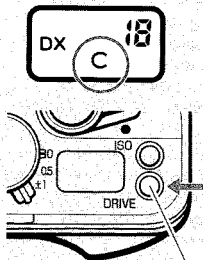

Drive Mode Button  
 Filmtransportaste  
 Bouton de mode d'entraînement  
 Botón del modo motorizado

**2** Set the drive mode to "C" and hold down the shutter release. Depending on the compensation value that has been set, pictures will be taken in the order of "standard", "over" and "under". The camera stops when three frames have been exposed.

When the drive mode is set to "S", each frame is exposed in the A. B. C. mode. When the drive mode is set to "☺", pictures are taken continuously in the A.B.C. mode after ten seconds.

In the A.B.C. mode, the exposure counter will change in the following order to show the order of shots.

Standard Exposure : Both left and right digits blink  
 Overexposure: Left digit blinks  
 Underexposure: Right digit blinks



*Standard Exposure*  
*Normalbelichtung*  
*Exposition standard*  
*Exposición estándar*







*Overexposure*  
*Überbelichtung*  
*Surexposition*  
*Sobreexposición*



*Underexposure*  
*Unterbelichtung*  
*Sous-exposition*  
*Subexposición*

Example: Pictures taken in the A.B.C. mode from frame no. 18

<b>Compensation:</b>	<i>First Shot</i> <i>Standard</i>	<i>Second Shot</i> <i>Over</i>	<i>Third Shot</i> <i>Under</i>	<i>(Repeated for subsequent frames)</i> <i>Standard</i>
<b>Counter:</b>				
<b>Display:</b>	<i>Left &amp; right blink</i>	<i>Left blinks</i>	<i>Right blinks</i>	<i>Left &amp; right blink</i>

- When the camera control range is exceeded by the compensation value, the limiting compensation value will apply.
- To cancel the A.B.C. mode after it has been activated, set the A.B.C. lever to "0."
- When the main switch is turned off and then on again in the A.B.C. mode, three frames will be exposed again in the A.B.C. mode as described above.

## Flash Photography

When taking pictures indoors or at night where shutter speed of slower than 1/30 sec. is required, use a flash. In combination with the Contax TLA Flash System, this camera is designed to provide "TTL direct light metering" in which the amount of flash light can be automatically controlled on the camera side. When using the TLA360 Flash Unit, be sure to read the section, "CONTAX TLA360 Flash Unit" on page 202.

When using standard X-contact flash unit, set the exposure mode selector lever to "X."

### <Taking Pictures on TTL Direct Light Metering>

**1** Mount the TLA flash unit on the camera and turn it on.

**2** Set the flash unit to "TTL AUTO." As soon as the flash is fully charged, the mark "⚡" will appear in the viewfinder and the shutter speed will automatically be set depending on the exposure mode.

### ■ Aperture-priority auto exposure mode (Av)

Measured value in ambient light	Automatically set shutter speed	Display
16 to 1/60 sec.	1/60 sec.	"60" lights
1/60 to 1/125 sec.	1/60 to 1/125 sec.	"60" lights--- "125" lights
1/125 to 1/4000 sec.	1/125 sec.	"125" lights

### ■ Shutter-speed-priority auto exposure mode (Tv)

Shutter dial setting	Automatically set shutter speed	Display
4 to 1/125 sec.	4 to 1/125 sec. (shutter speed which is set on dial)	
1/250 to 1/4000 sec.	1/125 sec.	"125" lights

### ■ Programmed auto exposure mode (P)

Measured value in ambient light	Automatically set shutter speed	Display
16 to 1/60 sec.	1/60 sec.	"60" lights
1/60 to 1/125 sec.	1/60 to 1/125 sec.	"60" lights--- "125" lights
1/125 to 1/4000 sec.	1/125 sec.	"125" lights

### ■ Manual (M), flash (X), and bulb (B) exposure:

- When “M” is used, the shutter speed cannot be automatically set by the camera. Be sure to set it manually to 1/125 sec. or slower.
- The shutter speed you have set will be indicated in the viewfinder.
- When “X” is used, the shutter speed is set to 1/125 sec. and “125” in the viewfinder will light.
- When “B” is used, “bLb” will light to indicate “Bulb Exposure.”

## 3 Set the aperture and shoot.

Exposure mode	Aperture
Ax, Tv, M, X, B	Set the aperture. The set value is used when shooting.
P	Set the aperture to minimum value (green). The aperture is set automatically (F4: ISO 100) The lens is automatically stopped down when ambient lighting improves.

- In the “Tv” mode, the aperture is not set automatically. Be sure to set it manually.
- After the flash has fired, the mark “⚡” will blink for two seconds if the subject was correctly exposed.
- When the mark “⚡” does not blink after shooting, change the aperture or the shooting distance because your subject will be underexposed.
- In the close-up shooting, even if the “⚡” mark blinks after shooting, overexposure may occur. Follow the instruction manual of the flash unit to get the desired shooting range.
- Be sure to set the A.B.C. lever to “0.”
- When the drive mode is set to continuous shooting mode “C,” consult your flash unit’s instructions regarding flash intervals and light output during continuous shooting.
- The coupling range of film speeds is ISO 25 to 800 (without exposure compensation).

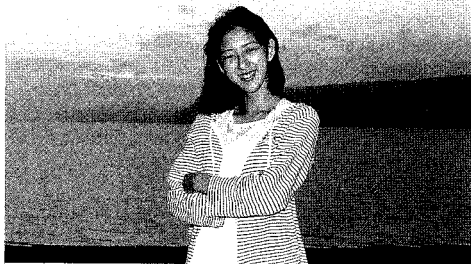

### <Slow-shutter Synchronization>

Slow-shutter synchronization at 1/30 sec. or slower is effective for taking nighttime pictures and twilight scenes with flash.

This camera facilitates slow-shutter synchronization in combination with a TLA flash unit.

- When taking slow-shutter synchro flash pictures, use a tripod to prevent camera shake because the shutter speed will be slow.



*With Normal Flash  
Mit gewöhnlichem Blitz  
Avec un flash normal  
Con flash normal*

### ■ In “Av”, “Tv”, or “P” exposure modes :

Set the main switch to “AEL.” In this case, the shutter speed will be locked at the measured value in ambient light. Make sure the flash is fully charged and shoot.

### ■ In “M” exposure mode:

Set the shutter speed at 1/30 sec. or slower. Adjust the aperture ring to the measured value in ambient light so that the exposure meter indicates “correct exposure” in the viewfinder. Make sure the flash is fully charged and shoot.

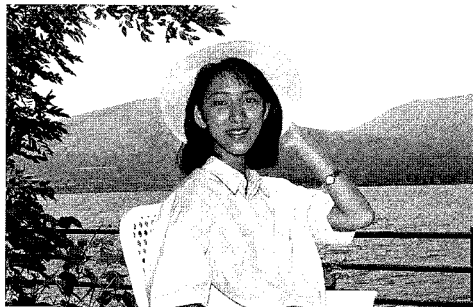

### <Daylight Flash>

Subjects under direct sunlight or backlight will turn out dark without exposure compensation or fill-in flash. When using the TLA flash in the TTL auto mode in such cases, both the subject and background will be beautifully exposed.

#### ■ In “Av” or “Tv” exposure mode:

If the “▲” mark blinks after the flash is fully charged, adjust the aperture ring to make the aperture slower until the “▲” mark disappears.



*Without flash  
Ohne Blitz  
Sans flash  
Sin flash*

#### ■ In “P” exposure mode:

In bright light, the exposure is automatically adjusted for daylight flash.

#### ■ In “M” or “X” exposure mode:

In the “M” mode, set the shutter speed dial to 1/125 sec or slower.

Adjust the aperture so that the exposure meter in the viewfinder indicates “correct exposure” and shoot.

### **<Using the Exposure Compensation Dial>**

In the TTL auto mode, the amount of flash light couples with the camera's exposure compensation dial.

If you want to bring out the mood by adjusting the amount of flash, use the exposure compensation dial.

### **<Verwendung der Belichtungskorrektur>**

Bei der TTL-Blitzbelichtungssteuerung wirkt sich ein an der Kamera eingestellter Korrekturfaktor auch auf das Blitzlicht aus.

Eine spezielle Korrektur für den Blitz können Sie direkt am TLA 360 einstellen.





Picture taken with second curtain synchronization  
 Aufnahme mit Synchronisation auf den 2. Verschußvorhang  
 Photo prise avec synchronisation au second rideau  
 Foto sacada con sincronización de la segunda cortina

### <Second Curtain Synchronization>

Second curtain synchronization is very useful for shooting moving subjects when using slow-shutter synchronization. In ordinary flash photography, the flash is fired immediately after the first curtain of the shutter has completed traveling (first curtain synchronization).

In combination with a Contax flash having a second curtain synchronization capability, this camera can trigger the flash just before the



Picture taken with first curtain synchronization  
 Aufnahme mit Synchronisation auf den 1. Verschußvorhang  
 Photo prise avec synchronisation au premier rideau  
 Foto sacada con sincronización de la primera cortina

second curtain starts to travel (second curtain synchronization). Behind the subject illuminated by flash light, the movement of the subject illuminated by ambient light is captured like a flowing line so that its natural movement is depicted clearly.

- The exposure is controlled in the same way as for ordinary flash photography (first curtain synchronization).

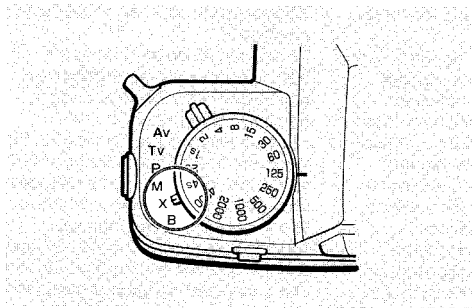

### <Taking Pictures Using X-contact Flash Units Other than TLA Flash Unit>

**1** Mount the flash unit on the camera. Set the exposure mode selector lever to "X."

The shutter speed is set to 1/125 sec.

- It does not matter where the shutter speed dial is set.

### **2** Set the aperture and shoot.

Set the aperture according to the instructions for the flash unit you use.

- When using a cord type flash that has no direct contact, connect the cord to the sync terminal on the side of the camera.

## Multiple Exposure



*Blinks  
Blinkt  
Clignote  
Parpadea*

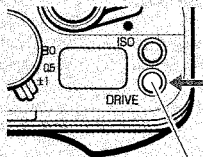

*Drive Mode Button  
Filmtransporttaste  
Bouton de mode  
d'entraînement  
Botón del modo motorizado*



*Lights  
Leuchtet  
S'allume  
Se enciende*

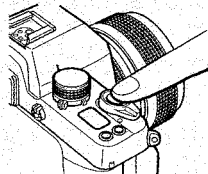

Special effects can be achieved by superimposing different or identical subjects in the same frame.

### **1** Set the drive mode button to select the multiple exposure mode “”.

\* For information on settings, see section, “Drive Mode Button” on page 70.

The “” mark on the display panel blinks.

### **2** Depress the shutter release.

The first exposure is made, shutter is cocked but the film is not advanced.

The “” mark on the display panel is now lit continuously.

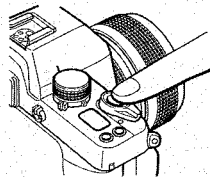
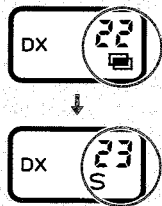

### 3 Press the shutter release a second time.

After the second exposure, the film is advanced and the multiple exposure is completed.

- When the multiple exposure has been made, the camera is reset to "S" drive mode.
- Even if the main switch is turned off after the first exposure, the camera is ready for the second exposure when the main switch is turned on again.
- The multiple exposure mode is canceled if the camera is set to some other drive mode before exposure.
- Note that the multiple exposure mode cannot be canceled when the first exposure has been made.
- The multiple exposure mode is canceled if the main switch is turned off when the "📷" mark on the display panel blinks. The next time the main switch is turned on, the camera goes on in drive mode "S."



Lights  
Leuchtet  
S'allume  
Se enciende



Blinks  
Blinkt  
Clignote  
Parpadea

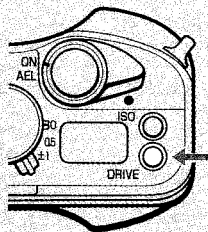

**To make 3 or more multiple exposures:**

Press the drive mode button after step 2 on page 164 to change the “” mark on the display panel from steady light to blinking. This action will allow you to make one more exposure. You can repeat this action to make as many exposures you wish.

## Using the Self-timer

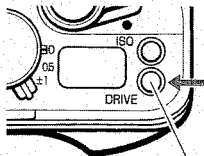
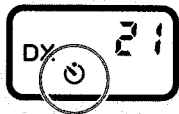

*Drive Mode Button  
Filmtransporttaste  
Bouton de mode d'entraînement  
Botón del modo motorizado*

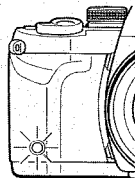

*Self-timer LED  
Selbstausslöser-LED  
LED de retardeur  
LED del disparador automático*

### **1** Set the drive mode button to select the self-timer mode “”.

\* For details, see section, “Drive Mode Button” on page 70.

### **2** Focus the lens on your subject and depress the shutter release.

The self-timer will start to operate and the shutter will be tripped after ten seconds. When the self-timer is operating, the self-timer LED on the front of the camera blinks.

- Mount the camera on a tripod when you are using the self-timer.
- The self-timer cannot be used when the camera is set to bulb exposure.
- When the shutter release is depressed while the self-timer is running, the counter will reset itself and be tripped after 10 seconds.
- To cancel the self-timer when it has started, turn the main switch off or press the drive mode button.

- 
- During automatic shooting using the self-timer, stray light may enter the viewfinder eyepiece and affect exposure since you cannot keep your eye at the viewfinder. To prevent this, attach the eyepiece cover over the eyepiece (see page 22).

- Pendant une prise de vue à retardement, une lumière parasite risque de pénétrer par l'oculaire du viseur et d'affecter l'exposition car l'œil ne masque plus l'oculaire. Pour éviter ceci, placez le cache sur l'oculaire (cf. page 23).

- 
- Verschließen Sie bei Aufnahmen mit Belichtungsautomatik das Sucherokular mit dem Okulardeckel (siehe S. 22), um Fehlbelichtungen durch einfallendes Streulicht zu vermeiden.

- 
- Durante el disparo automático con el disparador automático, es posible que entre luz en el ocular del visor y afecte la exposición porque no se puede tapar el visor con el ojo. Para evitarlo, coloque la cubierta del ocular sobre el ocular (vea la página 23).

*Other Functions*

*Sonstiges*

*Autres fonctions*

*Otras funciones*



## Custom Functions

This camera is provided with five custom functions which are described in the table below. The camera functions are set to standard mode when shipped (setting "0"). (Operations described in this instruction manual assume that the camera is used in standard mode ("0").)

When changing the custom functions, see section, "Setting the Custom Functions" on page 182.

- Camera operation changes when the custom functions are set. Read through the section, "List of Custom Functions" to make sure that you use the functions correctly.

### <List of Custom Functions>

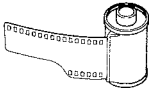
Function No.	Item No.	Standard Status (0)	Altered Status (1)
1: AE locking operation		Set main switch to "AEL" (continuous AE lock)	Depress the shutter release halfway down to engage the AE lock (not when the flash is being charged.) ● During continuous AE lock with main switch, continuous AE lock has priority.
2: Switching of A.B.C. shooting order		Shooting order: standard → over → under	Shooting order: over → standard → under
3: Remaining film when rewinding is completed		Film is completely rewound back into the cassette. 	The film end remains outside the cassette. 

Function No.	Item No.	Standard Status (0)	Altered Status (1)
<b>4: Rewinding at the end of the film</b>		Automatic rewinding	Rewinding with manual rewind button
<b>5: Film loading</b>		The film is automatically advanced when the camera back is closed.	The film is advanced when the back cover is closed, the main switch is turned on and the shutter release is pressed.

## Setting the Custom Functions

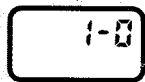

Custom Function Setting  
Position  
Position für Individual-  
Funktionseinstellung  
Position de réglage des  
fonctions personnalisables  
Posición de ajuste de las  
funciones personalizadas

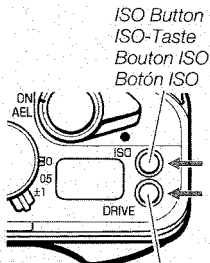

Drive Mode Button  
Filmtransporttaste  
Bouton de mode  
d'entraînement  
Botón del modo motorizado

Function No.  
Funktion Nr.  
Nº de función  
N.º de función

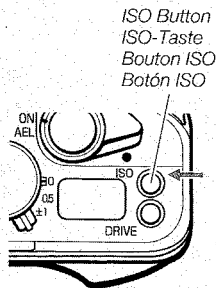

**2** Press the ISO button to select and display the function number to be set.

- Each time the ISO button is pressed, the function numbers are displayed in the following order: 1 → 2 → 3 → 4 → 5 → 1 (repeating).

**1** Turn the main switch on and hold down the ISO button and the drive mode button simultaneously until the indication shown in the illustration appears on the display panel (2 sec.).

Take your fingers off the buttons when the indication (custom function setting position) shown in the illustration appears on the display panel.

Item No.  
Funktion Nr.  
N° de rubrique  
Botón ISO

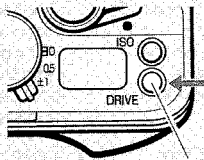

Drive Mode Button  
Filmtransportaste  
Bouton de mode d'entraînement  
Botón del modo motorizado

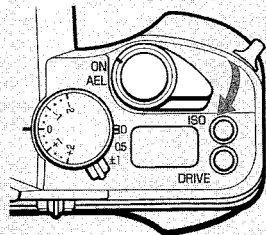

### 3 Press the drive mode button and select the desired item number.

- The item number changes each time the drive mode button is pressed. Select "0" or "1."

### 4 Turn the main switch off to complete the setting.

- The setting can also be completed by depressing the shutter release halfway or by leaving the camera idle for 16 seconds.

## Release Socket

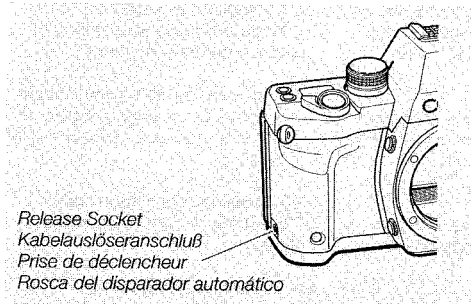

This socket is used for connecting cable switch L or Auto Bellows to transmit electric signals from these accessories to operate the shutter.

- During shooting using cable switch L, stray light may enter the viewfinder eyepiece and affect exposure since you cannot keep your eye at the viewfinder. To prevent this, attach the eyepiece cover over the eyepiece (see page 22).
- Do not connect cable releases sold on the market to the release socket as this may damage the socket.

## Detaching the Camera Back

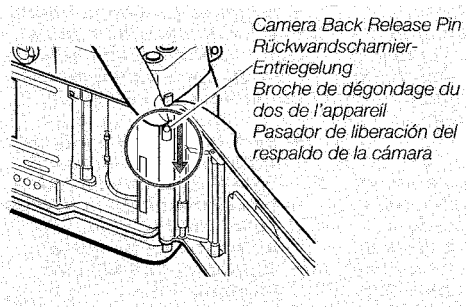

It is possible to detach the camera back and replace it with an optional Data Back D-9 (see page 212).

The camera back can be removed by pushing down the camera back release pin.

## Aperture Stop-down Button

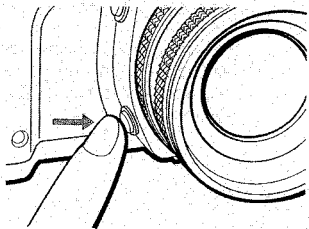

The lens will always remain wide open to provide a clearer view through the viewfinder. However, it can be stopped down to your desired aperture by depressing this button (the image in the viewfinder will become darker accordingly) to check the depth of field or the blurred effect on the background.

- You cannot get correct exposure when taking pictures or checking exposure with the aperture stop-down button.

### <Exposure>

Lighting to film. When a picture is taken, the aperture value and shutter speed adjusts the amount of light to the film.

### <Shutter speed>

The shutter in the camera controls the amount of light that reaches the film by the length of time it stays open. The time the shutter stays open is the shutter speed.

### <Aperture Value>

The aperture in the lens controls the amount of light going through the lens by becoming smaller or larger. The size of the opening produced by the size of the aperture is the aperture value.

### <Film Speed (ISO Value)>

Film speed is measured by values determined by ISO (the International Standardization Organization). A small ISO value means lower sensitivity but finer grain and higher image quality. A large ISO value means high sensitivity. Such films can be used in locations with poor ambient lighting or with fast shutter speeds, but it has coarser grain and therefore poorer image quality.

### <Belichtung>

Der Film wird Licht ausgesetzt. Beim Auslösen wird die Menge des auf den Film treffenden Lichts über die Einstellungen von Blende und Verschlusszeit geregelt.

### <Verschlusszeit>

Der Verschluss der Kamera regelt die Menge des auf den Film treffenden Lichts durch die Verschlusszeit, also die Dauer der Verschlussöffnung bzw. der Schlitzbreite zwischen 1. und 2. Vorhang.

### <Blendenwert>

Die Objektivblende regelt die Menge des durch das Objektiv einfallenden Lichts durch Verändern der Blendenöffnung. Der Blendenwert entspricht stets der Größe der Blendenöffnung.

### <Filmempfindlichkeit>

Die Filmempfindlichkeit wird durch einen ISO-Wert ausgedrückt (ISO = International Standardization Organization).

Je kleiner der ISO-Wert, desto geringer ist die Empfindlichkeit und umgekehrt. Gleichzeitig wird mit niedrigen ISO-Werten eine feinkörnige, hohe Bildqualität erzielt. Filme mit einem hohem ISO-Wert eignen sich besonders zum Fotografieren bei ungünstigen Lichtverhältnissen oder mit kurzen Verschlusszeiten, doch wirken die Aufnahmen grobkörniger, so daß eine Einbuße an Bildqualität hingenommen werden muß.



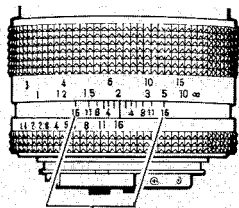

Depth of Field Scale  
 Schärfentiefskala  
 Echelle des profondeurs de champ  
 Escala de la profundidad de campo

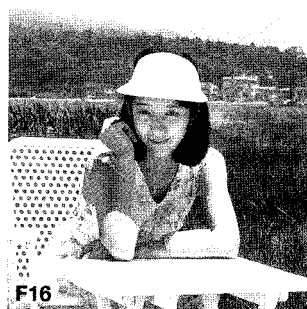
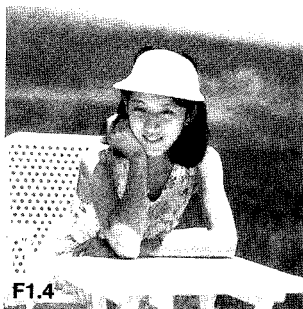

### <Depth of Field>

When a subject is in focus, not only the subject itself but also some area in front and behind the subject will also be sharp. The range between the nearest and farthest points that are sharp is the depth of field.

- ① The depth of field increases with small apertures and decreases with large apertures.
- ② The depth of field is larger for a distant subject and smaller for a near subject.

- ③ The depth of field is larger behind than in front a subject in focus. A lens with a long focal length (telephoto lenses) have narrower depth of field than a lens with short focal length.

The depth of field scale on a lens tells us the depth of field that it provides. For example, if we focus a 50 mm F1.4 standard lens on a subject 2 meters away and use an aperture of F16, the distance indicated by depth of field scale 16 shows that we obtain a depth of field from 1.4 m to 5 m.

## Camera Care and Precautions

- To remove dust and dirt on the lens and viewfinder glass, blow off with an air blower or wipe gently with a soft lens brush. If they are soiled with fingerprints, wipe off lightly with lens tissue. That is enough. Never use a bomb type blower. With its air pressure, dust and dirt may get farther into the camera interior. Wipe off dust and dirt on the mirror lightly with a lens brush
- To clean the camera exterior, wipe with the soft cloth. Never use benzene, thinner or other solvents.
- After taking pictures in a dusty place such as at the seaside or on mountains, clean the camera thoroughly. Salt air will cause corrosion and sand and dust will adversely affect the internal precision parts of the camera.
- Do not leave the camera in hot places (on an ocean beach in summer, in a parked car under direct sunlight, etc.) for a long time, because the camera, film and battery may be adversely affected.
- The lens and viewfinder may be clouded if the camera is brought into a warm room from outside where it is cold. This cloudiness will disappear soon, but it is always advisable to avoid sudden temperature changes because water droplets will cause internal corrosion.
- If you are going to use the camera for important events such as an overseas trip or wedding ceremony, be sure to test it beforehand to make sure it functions properly. It is also advisable to bring a spare battery with you.

- Because the camera is a precision device, do not expose it to excessive shock such as by dropping, etc.

### **Note on the Shutter Curtain:**

The shutter curtain is made of a very thin material. Never push it with a finger, or touch or wipe it. When changing film, take care that the film edge does not touch the shutter curtain. When using an air blower, do not blow air strongly on the curtain because it may be damaged or deformed. Never use a pressurized blower.

### **Microcomputer Protection Circuit:**

This camera incorporates a safety circuit to protect its microcomputer against strong external static electricity. Though rarely, it may fail to function because this safety circuit has come into action. In this case, set the main switch to OFF, remove the batteries, reload them and use the camera again.

### Caution on use of tripods

This compact camera is not designed to be mounted on a large tripod with Planar T\*85 mm F1.4, Makro-Planar T\*60 mm F2.8 or other wide diameter lenses attached. When the camera is mounted on such a tripod, the pedestal of the universal head comes into contact with the lens which could render the lens inoperable or even damage it.

Attach a separately sold quick shoe adapter between the camera and the tripod to prevent this from happening.

### About infrared film

Please note that this camera is not designed to operate with infrared film.

### <Camera Storage>

- Keep the camera away from heat, moisture and dust. Do not store it in a wardrobe drawer containing mothballs or in a laboratory where there are chemicals that will cause damage to it.
- If you are not likely to use the camera for an extended period of time, remove the batteries to prevent possible damage by battery leakage.
- Verwenden Sie einen Blasepinsel, um Staub und Schmutz von den Glasflächen des Objektivs und Suchers zu entfernen, oder reiben Sie diese sacht mit einer weichen Objektivbürste ab. Bei Verschmutzung mit Fingerabdrücken wischen Sie diese behutsam mit Objektivreinigungspapier ab. Diese Reinigungsmaßnahmen sind ausreichend. Verwenden Sie auf keinen Fall einen Bombenblasepinsel. Der hohe Luftdruck eines solchen Gerätes kann Staub und Schmutz in Innere der Kamera blasen. Reiben Sie die Spiegeloberfläche sacht mit einem Objektivpinsel ab.
- Reinigen Sie das Kameragehäuse mit einem weichen Tuch. Nehmen Sie niemals Benzin, Verdünnung oder andere organische Lösungsmittel.
- Reinigen Sie die Kamera gründlich nach dem Aufenthalt in feuchter oder staubiger Umgebung, z.B. Meer oder Gebirge. Feuchte und salzige Luft kann Korrosion bewirken, Sand und Staub die Funktion mechanischer Teile stören.
- Lassen Sie die Kamera nicht lange an heißen Orten (z.B. Strand im Sommer, geparktes Auto in der Sonne), denn Kamera, Batterie und Film könnten darunter leiden.
- Wenn die Kamera aus der Kälte in warme Umgebung gelangt, kann das Objektiv beschlagen. Diese Erscheinung verschwindet nach kurzer Zeit von selbst, doch sollte man abrupte Temperaturwechsel möglichst vermeiden, auch damit keine Korrosion im Kamerainnem entsteht.

***Optional  
Accessories***

***Sonderzubehör***

***Accessoires en  
option***

***Accesorios  
opcionales***

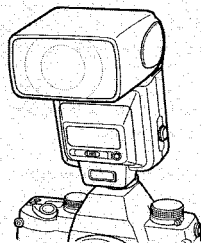

The TLA360 is a clip-on type TTL direct metering auto-flash unit with power zoom and guide number 36 (with 35 mm lens, square cover and ISO 100). Equipped with the automatic flash setting feature, the TLA360 can offer the following four functions in combination with Contax Aria.

- These functions can be used when the flash unit is directly attached to the accessory shoe on the camera top. The flash system is not automatically set when it is used off the accessory shoe and through the TLA extension code or TLA lighting system.

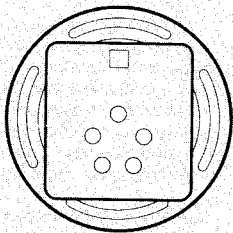

- The Contax TLA flash unit with auto flash setting feature has five contacts at the leg of the unit.
- Das Contax TLA360-Blitzgerät mit automatischer Einstellung ist mit 5 Kontakten am Blitzfuß ausgestattet.
- Le flash Contax TLA avec réglage entièrement automatique possède 5 contacts sur sa patte de fixation.
- El flash TLA Contax, con la función de ajuste del flash automático, tiene cinco contactos en la pata de la unidad.

## <1. Auto Setting>

Function	Auto film speed setting	Auto aperture setting
Flash mode		
TTL auto	<input type="radio"/>	<input type="radio"/>
Normal auto	<input type="radio"/>	<input type="checkbox"/>
Manual	<input type="radio"/>	<input type="radio"/>
Stroboscopic	<input type="radio"/>	<input type="radio"/>

- : The camera setting is automatically set to the flash unit. (At completion of flash unit charging)
- × : Not automatically set

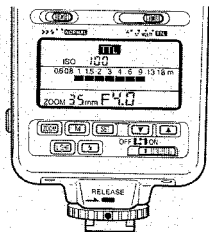

**1** Press the “SEL” button of the flash unit.

- The compensation scale appears on the display panel of the flash unit and the “+/-” mark starts to blink.

**2** Press the “▲” and “▼” buttons of the flash unit to set the desired value.

## <2. Flash Unit Light Compensation>

Light compensation can be used only in the “TTL auto flash” mode and in no other mode.

- Compensation is activated in 1/3 steps in the range of -3EV to +1 EV.
- The compensation amount of the flash unit is determined by the value of the camera’s exposure compensation. For example, if the camera’s compensation is “+1” and the flash unit’s compensation is “+1”, the amount of light from the flash unit is set to +2 (EV).

**3** Press the "SEL" button again. The "+/-" mark changes from blinking to steady lighting and compensation is completed.

- The compensation scale of the flash unit's display panel indicates the value set on the flash unit.
- When the compensation amount of flash unit is "0" (no compensation), the compensation scale will disappear in 8 seconds.

### **<3. Auto OFF and Auto ON>**

When the power switch of the flash unit is set to "Auto OFF", the flash unit is automatically powered off approximately 80 seconds. Also, by depressing the camera's shutter release halfway, "Auto ON" is activated to start charging of the flash unit. This power saving feature is useful during prolonged flash photography.

**3** Drücken Sie nochmals die "SEL"-Taste. Das Symbol "+/-" wechselt von Blinken auf Leuchten, womit der Korrekturfaktor eingegeben ist.

- Der eingestellte Korrekturfaktor wird auf der Korrekturskala im LCD-Monitor des Blitzes angezeigt.
- Wenn der Korrekturfaktor "0" (keine Korrektur) eingestellt ist, verschwindet die Korrekturskala nach ca. 8 Sekunden.

### **<3. "Auto OFF" und "Auto ON">**

Wenn der Hauptschalter des TLA360 auf "Auto OFF" steht, schaltet der Blitz bei Nichtgebrauch nach ca. 80 Sekunden ab. "Auto ON" bewirkt, daß der Blitz beim Antippen des Kameraauslösers mit dem Aufladen beginnt. Diese Energiespareinrichtung ist besonders bei längerem Fotografieren mit Blitz nützlich.

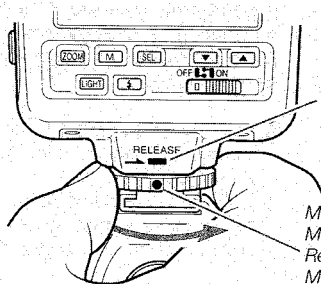

Mark on the mounting leg  
Blitzfuß-Markierung  
Repère sur la patte de fixation  
Marca de la pata de montaje

Mark on the shoe lock ring  
Markierung am Schuh-Verriegelungsring  
Repère sur la bague de blocage du sabot  
Marca en el anillo de bloqueo de la zapata

#### <4. Shoe Stopper>

The “mounting leg” of the TL360 has a shoe stopper (slip off protector) to prevent the flash unit from slipping off the camera unintentionally. Before mounting or removing the flash unit, never forget to line up the mark on the shoe lock ring index with the mark on the “mounting leg”.

\* The TL360 has a great number of functions in addition to those mentioned above. Refer to the TL360 Instruction Manual so that you will be able to avail yourself of all the functions it provides.



## Contax Data Back D-9 (multi-function type)

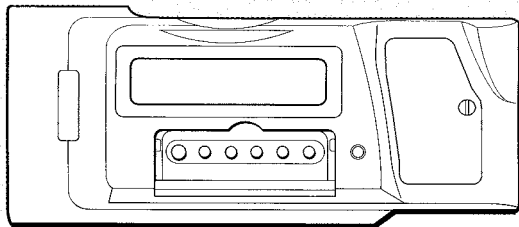

This multi-function data back can be used in place of the Contax Aria camera back. It has a “collective imprinting” function that can imprint exposure data on shooting on the first two frames of the film and a “between-the-frames” imprinting function that can imprint dates and exposure data between the frames. Because both functions can be used together, it is possible to record exposure data by setting the “collective imprinting” function and record dates, time or counter data between the frames so that they can be extensively used for classification of photos, storage and arrangement of exposure data, etc.

It also has an interval shooting function for controlling camera operation.

- Note that the D-9 Data Back cannot imprint on the frames itself.

### <Collective Imprinting Function>

Exposure data on shooting of each frame are recorded by the camera and these data are imprinted collectively on the first two frames when the film is rewound.

#### ■ Imprinted data

- ① Date of film loading (year, month, day and hour)
- ② Camera used "AR"
- ③ Exposure data (exposure compensation value, shutter speed, F-number, exposure mode)
- ④ Frame No. (every five frames)
- ⑤ Date of film rewinding (year, month, day and hour)

### <Sammeleinbelichtung>

Die Belichtungsdaten jeder Aufnahme werden in einem Speicher festgehalten und nach dem Zurückspulen des Films gesammelt auf das erste und zweite Negativ/Dia einbelichtet.

#### ■ Die folgenden Daten werden einbelichtet:

- ① Datum des Filmeinlegens  
(Jahr/Monat/Tag/Stunde)
- ② "AR" zur Kennzeichnung der verwendeten Kamera (Aria)
- ③ Belichtungsdaten (Belichtungskorrekturwert, Verschlusszeit, Blendenwert, Belichtungsart)
- ④ Bild-Nr. des Zählwerks (jede 5. Aufnahme)
- ⑤ Datum des Zurückspulens  
(Jahr/Monat/Tag/Stunde)

### <Between-the-frames imprinting function>

It is possible to choose one of the following eight modes and imprint data between film frames.

- ① Date (year, month and day)
- ② Date (month, day and year)
- ③ Date (day, month and year)
- ④ Hour (day, hour and minute)
- ⑤ Exposure data on shooting (exposure compensation value, shutter speed, F-number, exposure mode or two characters)
- ⑥ Counter data (4-digit add-up counter + exposure counter ) + two characters
- ⑦ Desired 6-digit fixed number + two characters
- ⑧ No imprint

### <Einbelichtung zwischen den Bildern>

Sie können einen der folgenden sieben Datentypen zwischen den Aufnahmen einbelichten oder "keine Einbelichtung" wählen.

- ① Datum (Jahr/Monat/Tag)
- ② Datum (Monat/Tag/Jahr)
- ③ Datum (Tag/Monat/Jahr)
- ④ Uhrzeit (Tag/Stunde/Minute)
- ⑤ Belichtungsdaten der Aufnahme (Belichtungskorrekturwert, Verschlußzeit, Blendenwert, Belichtungsart oder zwei Zeichen)
- ⑥ Zählwerkdaten (4stelliges addierendes Bildzählwerk + Bildzählwerk) + zwei Zeichen
- ⑦ beliebig wählbare 6stellige Zahl + zwei Zeichen
- ⑧ keine Einbelichtung

### **<Interval shooting>**

The interval shooting function makes it possible to take automatically the set number of pictures at the set interval, starting from the set time. It is convenient for observing changes with time or unattended shooting.

### **<Photographie à intervalles programmés>**

Cette fonction vous permet de prendre automatiquement un nombre donné de photos à un intervalle programmé en commençant à un moment déterminé. Cette fonction est pratique pour l'observation d'un changement dans le temps et pour la prise de vue sans la présence d'un opérateur.

### **<Automatische Intervall-Aufnahmen>**

Sie können automatisch ab einer festgelegten Startzeit eine festgelegte Zahl von Aufnahmen in einem festgelegten Zeitintervall machen. So erlaubt diese Funktion auf einfache Weise Fotoserien von sich im Lauf der Zeit verändernden Objekten sowie unbeaufsichtigte Aufnahmen.

### **<Fotografía de intervalos>**

La función de fotografía de intervalos hace posible tomar automáticamente el número ajustado de fotos al intervalo ajustado, empezando desde la hora ajustada. Es conveniente para observar los cambios producidos con el tiempo o para fotografiar sin tener que estar presente.

## Contax Power Pack Adapter GP-1

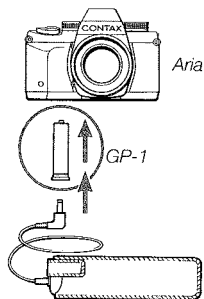

P-8 (optional)  
P-8 (nicht serienmäßig)  
P-8 (optionnel)  
P-8 (opcional)

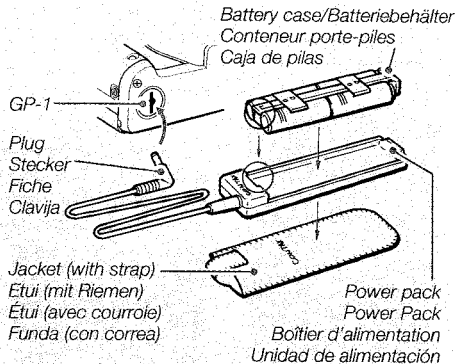

This adapter connects the Contax Power Pack P-8 (optional accessory) to Contax Aria. The P-8 is an external power supply which uses four 1.5 V AA-size alkaline batteries or four 1.2 V AA-size Ni-Cd batteries. In order to prevent the battery deterioration due to cold weather, the power pack is used to keep the camera power supply warm.

### ■ Installing the Power Adapter

#### 1 Install Power Pack Adapter GP-1 in the camera.

Remove the lithium battery in the camera and install GP-1 instead.

- Store the battery compartment cover in a safe place.

## **2 Load batteries in the Power Pack P-8.**

- ① Insert four type AA batteries in the supplied battery case according to the symbols in it. Install the battery case in the Power Pack P-8.
- ② Put the Power Pack into the jacket (case).

## **3 Insert the Power Pack P-8 plug into the power socket of the adapter GP-1.**

- It is advisable to protect the Power Pack under your coat or jacket when you are taking pictures in cold weather.
- When changing the batteries, do not mix different batteries or used batteries with new ones. Replace all the four batteries with new ones of the same type at the same time.
- When you are not going to use the Power Pack for quite some time, take the batteries out of the battery case to prevent battery leaks.
- To remove the connection cord, pull the plug and not the cord.

## **2 Legen Sie Batterien in das Power Pack P-8 ein.**

- ① Legen Sie vier Mignonzellen (AA/LR6) entsprechend den Polaritätsmarkierungen in den mitgelieferten Batteriebehälter ein. Setzen Sie dann den Batteriebehälter in das Power Pack P-8 ein.
- ② Stecken Sie das Power Pack in das Etui.

## **3 Stecken Sie den Stecker des Power-Pack-Kabels in die Buchse des Adapters G-1.**

- Es wird empfohlen, das Power Pack bei Aufnahmen in kaltem Wetter unter der Kleidung zu tragen, so daß die Batterien warmgehalten werden.
- Legen Sie beim Batteriewechsel nicht verschiedene Typen von Batterien oder alte und neue Batterien gemischt ein. Tauschen Sie immer alle vier Batterien gleichzeitig gegen solche des gleichen Typs aus.
- Wenn das Power Pack längere Zeit nicht verwendet werden soll, entfernen Sie die Batterien aus dem Batteriebehälter, um ein Auslaufen zu vermeiden.
- Beim Abziehen des Verbindungskabels immer am Stecker, nicht am Kabel selbst ziehen.

## ■ P-8 Specifications

**Configuration:** Power pack, battery case, jacket (with strap), length of cord: 1.5 m

**Power supply:** Four 1.5 V AA-size alkaline batteries or four 1.2 V AA-size Ni-Cd batteries (AA-size manganese batteries are not powerful enough and cannot be used)

## ■ Battery capacity

(Number of rolls 24-exposure film that can be exposed with new batteries, in accordance with Contax testing standards)

Battery type	Ordinary temperature
Four AA-size alkaline batteries:	approx. 25
Four 1.2 V AA-size Ni-Cd batteries:	approx. 10*

\* Use the Ni-Cd batteries fully loaded.

● Design and specification subject to change without prior notice.

## ■ Technische Daten des Power Pack P-8

**Lieferumfang:** Power Pack, Batteriebehälter, Etui (mit Riemen), Kabellänge: 1,5 m

**Spannungsversorgung:** Vier 1,5-V-Alkalibatterien oder vier 1,2-V-NC-Akkus der Größe AA/LR6.

## ■ Batteriekapazität:

(Anzahl von Filmen mit 24 Aufnahmen, mit frischen Batterien bei normaler Temperatur, gemäß Contax-Teststandard)

Batterietyp	normale Temperatur
Vier Alkali-Mignonzellen	ca. 25
Vier 1,2-V-NC-Akkus der Größe AA/LR6	ca. 10*

\* Die NC-Akkus müssen vollständig geladen sein.

● Änderungen in Technik und Design vorbehalten.

## FU Type Focusing Screens

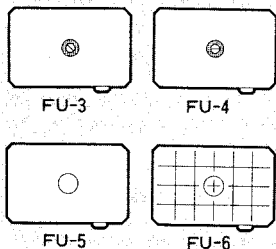

There are four interchangeable focusing screens for Contax Aria: FU-3, FU-4, FU-5, and FU-6. The screens have a 5 mm diameter circle in the center marking the spot metering area (FU-3 and FU-4 have a microprism as well).

- Never touch the focusing screens because they are machined to very high precision.

### **FU-4 (horizontal split-image/microprism screen):**

This screen is provided as standard on the Contax Aria. This screen enables you to focus using a center split-image spot, microprism collar around it, and a surrounding matte area making it suitable for a wide range of subjects.

### **FU-3 (45° split-image/microprism screen):**

Essentially the same as the FU-4, this screen has a 45° split image center spot ideal for focusing images with horizontal lines since you do not have to tilt the camera.

### **FU-5 (matte screen):**

This screen consists of a matte area all around and is suited for a relatively narrow-aperture lens such as a long-focus lens. It is also suited for close-up work and other situations when it is difficult to focus with a microprism or split-image spot.

### **FU-6 (sectioned matte screen):**

It has ruled lines at 6mm intervals on a matte screen and is especially suited for taking pictures using perspective control with Auto Bellows or PC Distagon or when it is necessary to precisely determine a composition during copying work, etc.



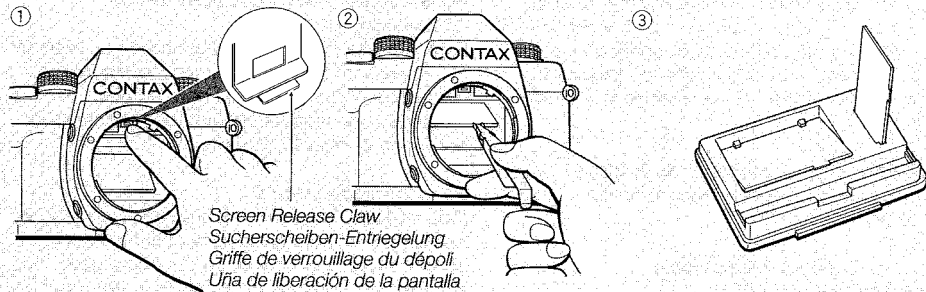

## <Replacing Focusing Screen>

\* Each screen is supplied with a pair of tweezers that should be used when screens are replaced.

The procedure described here for replacing focusing screens differs from that given in the FU Focusing Screen instruction manual. Use the procedure given below to replace focusing screens.

## 1 Removing the Screen

- ① Dismount the lens and gently push the screen release claw with your finger tip. This causes the screen and its frame to come forward. Gently lower the screen.
- ② Grip the protruding part of the screen with the supplied tweezers to remove it.
- ③ Place the removed screen in groove of the case to protect it from dirt and damage.

④

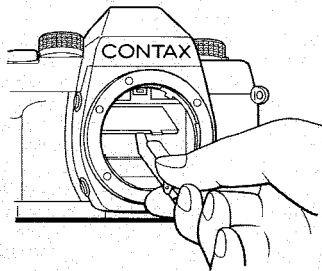

- When replacing the focusing screen, always use the supplied tweezers to prevent the mirror and screen against scratches and fingerprints.
- If the screen is soiled by dust, use a blower or soft lens brush to remove dust.
- If the screen is improperly mounted, it may come loose during shooting or it may become impossible to remove it. Should this happen, consult your nearest service station for proper handling.
- Unused screens should be stored in the screen case according to the instructions on the case.

## 2 Mounting the Screen

- ④ Hold the protruding part of the screen with the tweezers and insert it in the lowered frame. Then gently push tab of the frame (release claw) with the tweezers until it locks with a click. Finally, tap it with a finger to make sure the screen has been properly seated. This completes the mounting process.

## FL Type Diopter Lenses

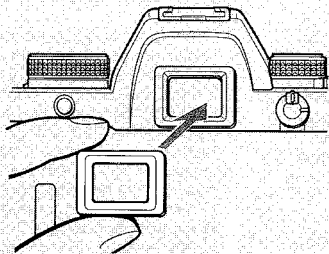

Optional diopter lenses can be attached as shown in the illustration above. The eyecup can then be mounted over the diopter lens.

Die als Zubehör erhältlichen Korrektionslinsen können wie in der Abbildung gezeigt angebracht werden.

Dann können Sie die Augenmuschel über der Korrektionslinse befestigen.

Des lentilles de correction dioptrique peuvent être installées comme indiqué sur l'illustration ci-dessus et un œilleton peut être installé sur la lentille dioptrique.

Las lentes diópticas opcionales puede colocarse como se muestra en la ilustración de arriba. El marco del ocular puede montarse entonces encima de la lente dióptica.

Those who are nearsighted or farsighted and have difficulty viewing the viewfinder can obtain optional diopter lenses that can be mounted in the viewfinder eyepiece.

Eight diopter lenses in the range from  $-5$  (D) to  $+3$  (D) are available.

## Flex Case C-6

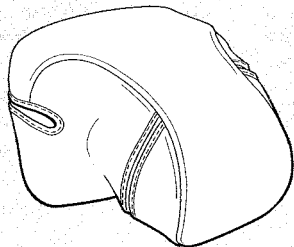

By extending or retracting the case end, this case accommodates the Contax Aria with a Data Back D-9 and the Carl Zeiss T\* lenses listed in the table below.

<b>State of case</b>	<b>C-6 (with one filter and lens cap)</b>
Lenses accommodated when retracted	FD16/2.8, D18/4, D25/2.8, D28/2.8, D35/2.8, T45/2.8, P50/1.4, P50/1.7, S85/2.8, S100/3.5, MP60/2.8C
Lenses accommodated when extended	D28/2, D35/1.4, P85/1.4, P85/1.2, MP60/2.8, VS35-70, VS28-70

## Specifications

**Type:** 35 mm focal-plane type AF single lens reflex camera.

**Picture Size:** 24 x 36 mm

**Lens Mount:** Contax/Yashica MM mount

**Shutter:** Vertical-travel focal-plane shutter.

**Shutter Speeds:**

16 sec. - 1/4000 sec. at "Av" and "P";

4 sec. - 1/4000 sec. at "Tv";

B, X (1/125 sec.), 4 sec. - 1/4000 sec. on manual.

**Sync Contacts:** Direct X contact (synchronizing speeds 1/125 sec. or slower) provided with direct contact and sync terminal

**Self-timer:** Electronic self-timer; trips the shutter after 10 sec. delay.

**Shutter Release:** Electronic release, provided with a special release socket.

**Exposure Control:** ① Aperture-priority auto exposure, ② Shutter-speed-priority auto exposure, ③ Programmed auto exposure, ④ Manual exposure, ⑤ TTL auto-flash, ⑥ Manual flash.

**Metering System:** TTL evaluative metering/center-weighted average light metering/spot metering switchover.

**Metering Range:** EV 2 - 20 (with an F1.4 lens and ISO 100 film)

**Film Speed Range:** ISO 25 - 5000 for automatic setting with DX code, ISO 6-6400 for manual setting

**AE Lock:** The quantity of light on the image surface is stored in memory.

**Exposure Compensation:** +2 EV to -2 EV (can be set in 1/3-step increments).

**A.B.C. Mode:**  $\pm 0.5$  EV/ $\pm 1$  EV exposure compensating values with A.B.C. lever.

**Flash Light Control:** TTL direct light control.

**Flash Synchronization:** In combination with dedicated flash, the shutter speed is automatically set when the flash is fully charged.

**Automatic Flash Setting:** Possible in combination with dedicated flash capable of automatic flash setting.

**Second Curtain Synchronization:** Possible in combination with dedicated flash capable of second curtain synchronization.

**Viewfinder:** Pentaprism eye-level finder (long eye-point type)

- Field of view 95%

- Magnification 0.82X

(With 50 mm normal lens at infinity, -1 D diop.)

**Dioptr Adjustment:** Eyepiece correction lenses can be attached (8 optional FL type diopter lenses)

**Focusing Screen:** Horizontal split-image/micropism type (FU-4) (standard), interchangeable screens (FU type) are also available.

**Viewfinder Display:** Flash mark, shutter speed, aperture value, metering mark, exposure warning mark, exposure meter, manual exposure mark, exposure compensation mark, exposure counter/self-timer remaining time/A.B.C. mode/film end

**Display Panel:** Exposure counter/A.B.C. mode/film speed/self-timer remaining time/elapsed time on bulb exposure/custom function mark, battery warning mark, self-timer mark, continuous shooting mark, single-frame shooting mark, multiple exposure mark

**Film Loading:** Auto loading, film automatically advances to "01" on exposure counter.

**Film Advance:** Automatic winding with built-in motor.

**Film Rewinding:** Automatic rewinding with built-in motor, automatic stop and mid-roll rewinding possible.

**Drive Modes:** Single frame, continuous, self-timer, multiple exposure

**Winding Speed:** Up to approx. 3 frames/sec. on continuous shooting ("C" mode) (with a new battery, at ordinary temperature, as tested according to Contax testing standard).

**Exposure Counter:** Display panel and viewfinder, both automatically resetting, additive type.

**Accessory Shoe:** Direct X-contact (provided with TLA flash contact).

**Custom Functions:**

- ① AE lock/unlock by depressing shutter release halfway
- ② Switching of A.B.C. shooting order
- ③ Film end is not wound into the cassette
- ④ Film not automatically rewound when film reaches end
- ⑤ Film advance method

**Camera Back:** Can be opened with camera back opening lever, detachable, with film check window

**Power Source:** Two 3 V lithium battery (CR2).

**Battery Check:** Automatic check, battery warning mark on display panel.

**Battery Capacity:** About 90 rolls of 24-exposure film (with a new battery, at ordinary temperature, as tested according to Contax testing standard)

**Other Details:** Aperture stop-down button

**Dimensions, Weight:**

137 (W) × 92.5 (H) × 53.5 (D) mm (depth excludes camera back and grip)  
460 g (excluding batteries)

*\* Specifications and design are subject to change without notice.*

To make full use of the capabilities of this camera, you are recommended to use our interchangeable lenses and accessories with it. Contax shall not be liable for any repair of damages arising from the use of third-party products made for use with Contax cameras.

## In Case of Difficulty

What may initially appear to be a malfunction is not always a real problem. So check the symptoms against the information in the table below before you decide to turn in the camera for service.

Symptom	Cause	Remedy	Page ref.
1. No indication in the display panel.	<ul style="list-style-type: none"><li>● No batteries are loaded.</li><li>● The batteries are depleted</li><li>● The batteries have been incorrectly loaded</li></ul>	<ul style="list-style-type: none"><li>● Load batteries</li><li>● Replace old batteries with new ones</li><li>● Reload the batteries correctly</li></ul>	26 26 26
2. The battery warning mark "  " blinks	<ul style="list-style-type: none"><li>● The batteries are depleted</li></ul>	<ul style="list-style-type: none"><li>● Replace the batteries</li></ul>	28
3. When the camera back is closed after inserting the film, the exposure counter blinks at "00"	<ul style="list-style-type: none"><li>● The film is not properly advanced</li></ul>	<ul style="list-style-type: none"><li>● Reload the film</li></ul>	56
4. The viewfinder display is difficult to view	<ul style="list-style-type: none"><li>● Incorrect diopter setting</li></ul>	<ul style="list-style-type: none"><li>● Use optional FL type diopter lenses</li></ul>	234
5. The shutter cannot be triggered	<ul style="list-style-type: none"><li>● The camera is set to the self-timer mode</li></ul>	<ul style="list-style-type: none"><li>● Set the camera to other drive mode</li></ul>	70

Symptom	Cause	Remedy	Page ref.
6. Pictures are blurred	<ul style="list-style-type: none"> <li>● Out of focus</li> <li>● The camera was moved when the shutter release was pressed</li> <li>● A slow shutter speed was used</li> </ul>	<ul style="list-style-type: none"> <li>● Make sure that you focus the lens so that the subject is sharp.</li> <li>● Press the shutter release gently to prevent camera shake.</li> <li>● Use a tripod.</li> </ul>	80 84 -
7. The exposure compensation mark is blinking	<ul style="list-style-type: none"> <li>● Exposure compensation is still on.</li> </ul>	<ul style="list-style-type: none"> <li>● Return the exposure compensation to "0."</li> </ul>	126
8. Only a single frame could be taken in A.B.C. mode	<ul style="list-style-type: none"> <li>● The shutter release was released to soon.</li> </ul>	<ul style="list-style-type: none"> <li>● Hold down the shutter release to shoot the three frames.</li> </ul>	142
9. During auto shooting, the exposure warning mark ("▲" or "▼") blinks	<ul style="list-style-type: none"> <li>● The subject is too bright or too dark.</li> </ul>	<ul style="list-style-type: none"> <li>● Adjust exposure according to instructions on page 106.</li> </ul>	106
10. The exposure counter is blinking (not at "00")	<ul style="list-style-type: none"> <li>● The A.B.C. lever is set to "±0.5" or "±1".</li> </ul>	<ul style="list-style-type: none"> <li>● Set the A.B.C lever to "0."</li> </ul>	140



Symptom	Cause	Remedy	Page ref.
11. When the shutter release is depressed halfway, the metering mark blinks.	<ul style="list-style-type: none"> <li>● Custom function "1-1" has been set.</li> </ul>	<ul style="list-style-type: none"> <li>● Set the custom function to "1-0."</li> </ul>	182
12. When film is loaded, the exposure counter is set to "03."	<ul style="list-style-type: none"> <li>● The collective imprinting switch of Data Back D-9 is on (when data back is used).</li> </ul>	<ul style="list-style-type: none"> <li>● Set the collective imprinting function to "OFF" when the next film is loaded.</li> </ul>	*
13. Film rewinding is interrupted.	<ul style="list-style-type: none"> <li>● Same as above.</li> </ul>	<ul style="list-style-type: none"> <li>● Same as above</li> </ul>	*

\* For details regarding 12 and 13, refer to the instruction manual supplied with the Contax D-9 data back.



## KYOCERA CORPORATION

### Optical Equipment Group

2-14-9, Tamagawadal, Setagaya-ku, Tokyo 158-8610 Japan

Tel (03) 3708-4506

<http://www.kyocera.co.jp/>

### KYOCERA OPTICS, INC.

2301-200 Cottenail Lane, Somerset, New Jersey 08873, U.S.A.

Tel (732) 560-0060

### KYOCERA OPTICS, INC.

6020 Irwindale Avenue, Unit A-C, Irwindale, California 91706, U.S.A.

Tel (626) 812-8888

### KYOCERA OPTICS, INC.

6200 Dixie Road, Unit 11, Mississauga, Ontario, L5T 2E1, Canada

Tel (905) 564-9385

**YASHICA Kyocera GmbH**, Eifestraße 76, D-20537 Hamburg, F.R.Germany

Tel (040) 25 15 07 0

**YASHICA Handelsges. mbH**, Rustenschacherallee 38, A-1020 Wien, Austria

Tel (01) 728 09 260

**YASHICA AG**, Zürcherstraße 73, CH-8800 Thalwil, Switzerland

Tel (01) 720 24 34

**KYOCERA YASHICA (U.K.) Ltd.**, Unit 7, Suttons Industrial Park, Sutton Park

Avenue, Earley Reading, RG6 1AZ, U.K. Tel (0118) 935 6300

**KYOCERA YASHICA (FRANCE) S.A.**, 1, allée de l'Épervier, 93420 Villepinte,

France. Tel: (1) 49 63 89 74

**KYOCERA YASHICA DO BRASIL INDUSTRIA E COMERCIO LTDA.**

Av. Bernardino de Campos No. 98, 5. Andar Paraisópolis, São Paulo, CEP. 04004-000,

Brazil. Tel: (011) 889-8055

**UNIVERSAL OPTICAL INDUSTRIES LTD.**, 14/F, Piazza Industrial Building,

193, Hoi Bun Road, Kwun Tong, Kowloon, Hong Kong. Tel. 2342 5151