



Taking care of your camera

- Do not use your camera in the following environmental range: temperature below 0°C or above 40°C.
- Do not use or store your camera in the environments listed below:
 - Direct sunlight
 - High and dusty places
 - Next to an air conditioner, electric heater or other heat sources
 - In a closed car that is in direct sunlight
 - Unstable locations
- If your camera becomes wet, wipe it with a dry cloth as soon as possible.
- Salt or seawater may cause severe camera damage.
- Do not use solvents, such as alcohol, to clean your camera.
- If the lens is dirty, use a lens brush or soft cloth to clean the lens. Do not touch the lens with your fingers.
- To prevent electric shock, do not attempt to disassemble or repair your camera by yourself.
- Water may cause a fire or electric shock. Therefore, store your camera in a dry place.
- Do not use your camera outdoors when it is raining or snowing.
- Do not use your camera in or near water.
- If a foreign substance or water gets in your camera, please turn the power off immediately and disconnect the batteries and the power adapter. Remove the foreign substance or water, and send it to the maintenance center.
- Transfer the data to the computer as soon as possible to avoid losing your images and/or video clips.

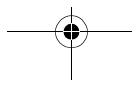
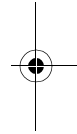
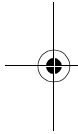
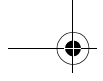

Table of Contents

- 1. Touring Your Camera** 1
 - 1.1 Checking the Package Contents 1
 - 1.2 Camera Components..... 1
 - 1.2.1 Front View..... 1
 - 1.2.2 Rear View 2
 - 1.2.3 LED Indicators 2
- 2. Preparing Your Camera for Use** 3
 - 2.1 Installing the Battery 3
 - 2.2 Charging the Battery..... 3
 - 2.3 Inserting and Removing an SD Memory Card 4
 - 2.4 Setting the Date and Time 4
- 3. Using the Camera** 5
 - 3.1 Snapshot Mode 5
 - 3.1.1 Getting started with capturing images..... 5
 - 3.1.2 Snapshot Mode LCD Monitor Information 6
 - 3.1.3 Changing Camera Settings..... 7
 - 3.1.4 Setting Shooting Mode 7
 - 3.1.5 Using the Flash..... 8
 - 3.1.6 Using the Self-timer 9
 - 3.1.7 Using the Optical Zoom..... 9
 - 3.1.8 Using the Digital Zoom..... 10
 - 3.1.9 Changing the Focus..... 10
 - 3.1.10 Adjusting the EV..... 10
 - 3.1.11 Snapshot Mode Menu Settings 11
 - 3.1.11.1 Snapshot Mode Menu 11
 - 3.1.11.2 Using the Interval Shoot 12
 - 3.2 Movie Mode..... 13
 - 3.2.1 Movie Mode LCD Monitor Information 13



English



3.2.2	Movie Mode Menu Settings	14
3.2.2.1	Movie Mode Menu	14
3.2.3	Timer Recording.....	15
3.3	Playback Mode.....	15
3.3.1	Playback Mode LCD Monitor Information (Image) ..	16
3.3.2	Viewing Images	16
3.3.2.1	Magnifying Images	16
3.3.2.2	Thumbnail Display (Index Playback)	16
3.3.2.3	Voice Memo.....	17
3.3.3	Deleting Files	17
3.3.4	Playback Mode Menu Settings.....	17
3.3.4.1	Playback Mode Menu	17
3.3.5	Playback Mode LCD Monitor Information (Video) ..	19
3.3.6	Playing Back Video Clips.....	19
3.4	Setup Mode.....	19
3.4.1	Setup Mode Menu	20
4.	PC Dependent Features.....	23
4.1	Bundled Software	23
4.2	USB Mode.....	24
4.3	Printer Mode.....	24
5.	Troubleshooting	25
6.	Specifications	27

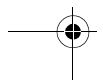
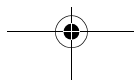
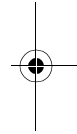
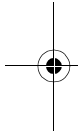

1 TOURING YOUR CAMERA

1.1 Checking the Package Contents

Carefully unpack your kit box and ensure that you have the following items.

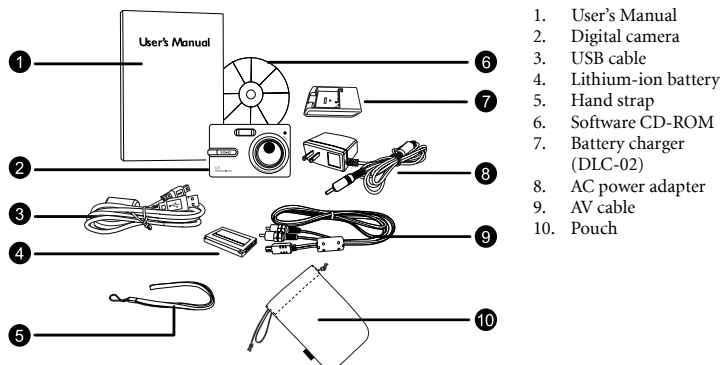

If any of the items are missing or appear to be damaged, contact your dealer. Save the packaging in case you need to ship your camera for service.

1.2 Camera Components

1.2.1 Front View

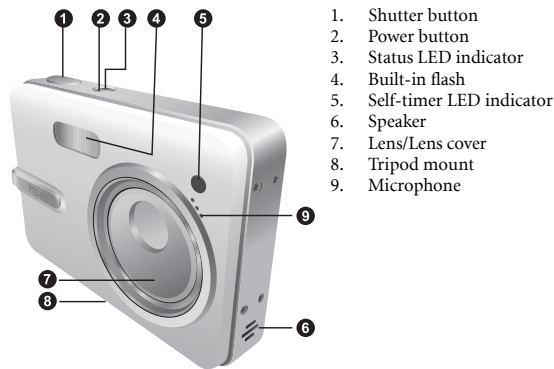

1.2.2 Rear View

1. LCD monitor
2. Inst. Play button
3. Inst. REC button
4. Strap eyelet
5. USB / AV port
6. Navigator -- four-way and **OK** buttons
7. Menu button
8. DISP button

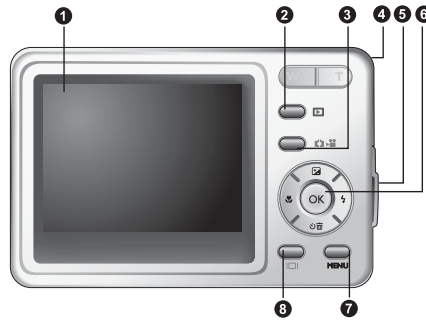

1.2.3 LED Indicators

Indicators	State	Description
Status LED indicator	Solid green	<ul style="list-style-type: none"> • The camera is powered up and ready to be used. • The USB connection is in progress. • The camera is in the power saving mode.
	Blinking green	<ul style="list-style-type: none"> • The camera is processing or accessing data.
	Blinking red	<ul style="list-style-type: none"> • There are error or warning messages.
Self-timer LED indicator	Solid red	<ul style="list-style-type: none"> • The sound recording or movie recording functions are activated.
	Blinking red	<ul style="list-style-type: none"> • The self-timer function is activated.

• The LCD on the digital camera is manufactured with sophisticated technology; however, the display may have some light spots or show unusual colors. This is normal and does not indicate display malfunction, nor will this affect the pictures you take with the camera.

2 PREPARING YOUR CAMERA FOR USE

2.1 Installing the Battery

We highly recommend that you use only the specified rechargeable lithium-ion battery for your camera. Make sure that the power of the camera is off before inserting or removing the battery.

To insert the battery:

1. Open the battery/SD memory card cover (A).
2. Insert the battery in the correct direction shown (B).
3. Push the battery all the way down, until the battery lock lever clicks into place (C).
4. Close the battery/SD memory card cover (D).

To remove the battery:

1. Open the battery/SD memory card cover.
2. Release the battery lock lever.
3. When the battery has come out a little, gently pull it out the rest of the way.

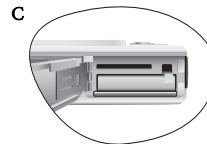
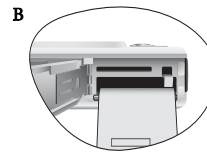

2.2 Charging the Battery

The battery charge status affects the performance of the camera. To maximize the performance and life of the battery, it is recommended that you fully charge the battery using the specified charger set (charger and AC power adapter), and then fully discharge it through the normal use at least one time.

1. Insert the battery into the charger as shown in the illustration.
2. Connect one end of the AC power adapter to the charger.
3. Connect the other end of the AC power adapter to a wall outlet.
4. When the battery is being charged, the charger LED indicator lights up in red. When the battery is fully charged, it turns into green.

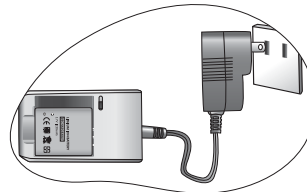

The length of the charging time depends on the ambient temperature and the status of the battery.

- The camera must be used with the specified charger set. Damage caused by the use of an incorrect charger set is not covered under the warranty. Always make sure that the camera is off before removing the battery.
- The battery may be warm after being charged or used. This is normal and not a malfunction.
- When using the camera in cold environments, keep the camera and its battery warm by holding it inside your jacket or other warm protective environment.

2.3 Inserting and Removing an SD Memory Card

The camera is equipped with 24MB internal memory, allowing you to record video clips, capture images, or make voice files in the camera. You can also expand the memory capacity by using an optional SD (Secure Digital) memory card to store more files.

1. Always make sure the camera is turned off before inserting or removing a memory card.
2. Insert an SD memory card in the correct direction, as shown in the illustration.
3. Close the battery/SD memory card cover.

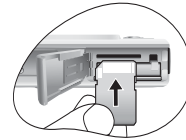

To remove the SD memory card, make sure the camera is turned off. Press lightly on the edge of the memory card and it will eject.

- Be sure to format the SD memory card with this camera before the initial use.
- To prevent valuable data from being accidentally erased from an SD memory card, you can slide the write-protect tab (on the side of the SD memory card) to "LOCK".
- To save, edit, or erase data on an SD memory card, you must unlock the card.
- While formatting the internal memory, do not insert a memory card into the camera. Otherwise, the memory card is formatted instead of the camera's internal memory.
- Formatting is an irreversible action and data cannot be recovered at a later time. Back up your data before formatting.
- An SD memory card having read or write problems may not be properly formatted.
- SD memory cards in the following sizes are supported: 8 MB, 16 MB, 32 MB, 64 MB, 128 MB, 256 MB, 512 MB, and 1 GB. The camera is compatible with SD memory cards manufactured by Panasonic, Toshiba, and Sandisk. Please contact your local dealer for purchasing information.

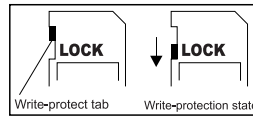

2.4 Setting the Date and Time

Before using your camera for the first time, please set the date and time. For more information, refer to the table in 3.4.1 "Setup Mode Menu" on page 20.

3 USING THE CAMERA

3.1 Snapshot Mode

3.1.1 Getting started with capturing images

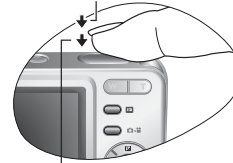

1. Press the [] button to turn on the camera.
2. Compose your image in the LCD monitor under Snapshot Mode.
3. Press the shutter button down halfway (1), and then press it down fully (2).

① Press down halfway



② Press down fully











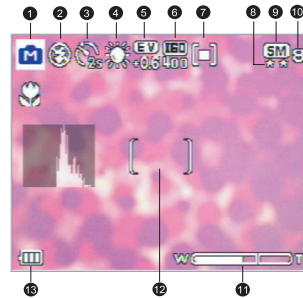





















- To review the last captured image, press the [] button. Press the [] button to return to Snapshot Mode.
- The LCD monitor darkens in strong sunlight or bright light. This is not a malfunction.
- To prevent your images from being blurred while pressing the shutter button, always hold the camera steady. This is especially important when you are shooting under low lighting conditions, under which your camera may reduce the shutter speed to ensure your images are properly exposed.
- Pressing the [] button changes the LCD display in the sequence of: OSD Normal → Detailed Info. → Info. Off.
- If QuickView is set to "On", the captured image will be displayed while the image is being written onto the memory.

English

3.1.2 Snapshot Mode LCD Monitor Information

1. Shooting Mode
 - [] Auto
 - [] Manual
 - [] Portrait
 - [] Landscape
 - [] Night Scene
 - [] Sport
 - [] Back Light
 - [] Night Scene Portrait



2. Flash mode
 - [] Flash Auto
 - [] Flash On
 - [] Flash Off
 - [] Red Eye
 - [] Slow Sync
3. Self-timer icon (if used)
 - [] Self-timer (2s)
 - [] Self-timer (10s)
 - [] Interval Shoot
4. White Balance (if chosen [Detailed Info] display)
 - [] Auto WB
 - [] Sunny
 - [] Cloudy
 - [] Tungsten
 - [] Fluorescent
5. EV (Exposure Value)
 - 0.3, -0.6, -1.0, -1.3, -1.6, -2.0, +0.3, +0.6, +1.0, +1.3, +1.6, +2.0
6. ISO
 - [] ISO Auto
 - [] ISO 100
7. Metering
 - [] Center Avg.
 - [] Spot
 - [] Average
8. Image Quality
 - [] Fine
 - [] Normal
9. Resolution (Image size)
 - [] 2816 x 2112
 - [] 2304 x 1728
 - [] 1600 x 1200
 - [] 1280 x 960
 - [] 640 x 480
10. Available number of shots
11. zoom status
12. AF Area
13. Battery power level indicator
 - [] Full battery power
 - [] Medium battery power
 - [] Low battery power
 - [] Virtually no battery power

3.1.3 Changing Camera Settings

Camera settings can be changed with the following four-way and **OK** buttons.

1. **Up/EV:**
 - Scrolls upwards in menus.
 - Enables you to adjust the EV settings.
2. **Left/Focus:**
 - Scrolls left in menus.
 - Enables you to choose the appropriate focus settings.
3. **Down/Self-Timer/Interval shoot/Delete**
 - Scrolls downwards in menus.
 - Toggles the self-timer settings.
 - Triggers Interval shoot.
 - Delete images, video clips or voice memos.
4. **Right/Flash:**
 - Scrolls right in menus.
 - Enables you to choose the appropriate flash settings.
5. **OK:** Confirms the chosen setting.

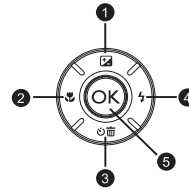

3.1.4 Setting Shooting Mode

You can set Shooting Mode for capturing images according to the following steps.

1. In Snapshot Mode, press the [MENU] button. Shooting Mode menu is displayed.
2. Use the [Up] / [Left] buttons to select the desired mode, and then press the **OK** button to confirm.



The table below will help you choose appropriate Shooting Mode:

Icon	Shooting Mode	Description
[A]	Auto	Select this mode when you want to leave the settings up to the camera to capture images with ease.
[M]	Manual	Select this mode when you want to adjust the settings of White Balance, Metering, and ISO. These menus are only available in Manual mode.
[P]	Portrait	Select this mode when you want to capture an image that makes the person stand out against a defocused (blurred) background. The flash is fixed at [Eye], which is effective in reducing the red-eye phenomenon.
[L]	Landscape	Select this mode to enhance the color saturation in mountains, forests and other landscape scenery or to take portraits that feature a landmark in the background. The flash is fixed at [Flash].
[N]	Night Scene	Select this mode when you want to take a photograph with an evening or night scene background. The flash is fixed at [Flash].

English

Icon	Shooting Mode	Description
	Sport	Select this mode when you want to capture fast-moving subjects. The flash is fixed at
	Back Light	Select this mode while capturing images with the light coming from behind the subject. The flash is fixed at
	Night Scene Portrait	Select this mode when you want to have a clear shot of the subject and the background. The flash is always on in this mode.

- The description of each Shooting Mode serves as a general guide for your convenience. Set the digital still camera to suit your preferences.
- Shooting Mode can be set only in Snapshot Mode.

3.1.5 Using the Flash

The flash is designed to function automatically when lighting conditions warrant the use of flash. You can capture an image using a flash mode suitable to your circumstances. If you change the flash mode, the camera will retain that setting even if the camera is turned off.

1. In Snapshot Mode, Flash Auto is activated by default.
2. Toggle the button to select other flash modes, if desired.
3. Compose your image and press the shutter button.

The table below will help you choose the appropriate flash mode.



Icon	Flash	Description
	Flash Auto	The flash fires automatically according to the photographic conditions.
	Flash On	The flash will always fire regardless of the surrounding brightness. Select this mode for capturing images with high contrast (backlighting) and deep shadows.
	Flash Off	The flash will not fire. Select this mode in a place where flash photography is prohibited, or when the distance to the subject is beyond the effective range of the flash.
	Red Eye	This mode can reduce the red-eye phenomenon when you want to capture natural-looking images of people and animals in low-light conditions. When capturing images, the red-eye phenomenon can be reduced by asking the subject (person) to look at the camera lens or get as close to the camera as possible.
	Slow Sync	This mode opens the shutter for a longer than normal period and fires the flash just before it closes. Select this mode for illuminating a foreground subject yet allowing a darker background to be rendered as well. It is appropriate for capturing the night scene with people in the foreground.

- The flash cannot be used in Movie Mode.
- If you select Slow Sync, to avoid blur, using a tripod and photographing static subjects are recommended.

3.1.6 Using the Self-timer

The self-timer can be set in Snapshot Mode. This feature is useful for situations when you may wish to be part of the picture.

1. Secure the camera to a tripod or place it on a stable surface.
2. In Snapshot Mode, toggle the [] button to select the desired self-timer mode.

Icon	Self-timer	Description
[]	Self-timer (2s)	The camera automatically takes a picture after two seconds delay.
[]	Self-timer (10s)	The camera automatically takes a picture after ten seconds delay.
[]	Interval Shoot	The camera automatically takes a picture every preset time till media full or battery empty.

3. Compose your image and press the shutter button.

- The self-timer function is activated and the countdown status is displayed on the LCD monitor.
- The self-timer LED indicator flashes and the image will be captured after the preset time has elapsed.
- To cancel the self-timer at any time, press the [] button.



- **The self-timer setting is automatically turned off after an image is captured.**

3.1.7 Using the Optical Zoom

Zoom photography allows you to capture images magnified up to 3 times or wide-angle photography depending on the distance up to the subject. You can further enlarge the center of the screen and capture images using the digital zoom.

1. Press the [] button to enter Snapshot Mode or Movie Mode.
2. Compose the image with the zoom key.
 - Adjusting the key to the right zooms in on the subject, and enlarges the subject on the LCD monitor.
 - Adjusting the key to the left provides a wide angle image.
 - The lens position moves according to the zoom setting only in optical zoom period.
3. Press the shutter button down halfway to set the focus and exposure, and then press it down fully to capture the image.







- **Zoom function cannot be used while a video clip is being recorded. Set the zoom before you start recording.**

3.1.8 Using the Digital Zoom

Using a combination of 3X optical zoom and 4X digital zoom permits zoom photography up to 12X to suit the subject and the distance. Digital zoom is a useful feature; however, the more an image is enlarged (zoomed), the more pixelated (grainy) the image will appear.

3.1.9 Changing the Focus



1. In Snapshot Mode, toggle the [] button to switch between the following modes.

Icon	Focus	Description
	Normal (AF)	Normal Auto Focus (50 cm to infinity).
[]	Macro	Macro Auto Focus (6 cm). The flash is fixed at [].
[]	Pan Focus (PF)	This option can decrease the time of focusing and enhance the efficiency of capturing images. It helps you capture fast-moving subjects or subjects in the dark easily. The depth of field in [PF] Mode: <ul style="list-style-type: none"> - The depth of field in Wide End of Zoom Lens: 1m ~ 5m - The depth of field in Middle End of Zoom Lens: 1m ~ 4m - The depth of field in Tele. End of Zoom Lens: 1m ~ 3m

2. Compose the image.
3. Press the shutter down halfway, and then press it down fully.

3.1.10 Adjusting the EV

The EV (exposure value) enables you to lighten or darken an image. Use this setting when the brightness between the subject and the background is not balanced, or when the subject occupies only a small part of the photograph.

1. In Snapshot Mode, make sure Shooting Mode is set to [Auto] or [Manual]. For more information on setting Shooting Mode, refer to 3.1.4 "Setting Shooting Mode" on page 7.
2. Press the [] button. The EV adjustment bar will be displayed on the bottom of the LCD monitor.
3. By default, the EV is 0. It can be adjusted between -2.0 to +2.0.
 - To increase the EV bias, press the [] button and then press the **OK** button.
 - To decrease the EV bias, press the [] button and then press the **OK** button.

3.1.11 Snapshot Mode Menu Settings





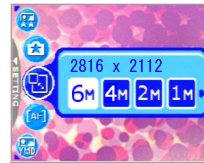









3.1.11.1 Snapshot Mode Menu

1. In Snapshot Mode, press the [MENU] button to access the menu, and then use the [] / [] buttons to select the menu settings you want to change.
2. Use the [] / [] buttons to select the desired item in the menu, and then press the OK button.
3. To exit from the menu, press the [MENU] button.



Icon	Item	Option	Functional Description
[]	Resolution	[6M] 2816 x 2112 [4M] 2304 x 1728 [2M] 1600 x 1200 [1M] 1280 x 960 [VGA] 640 x 480	Sets the size of the image that will be captured. 💡 Higher resolution images require more memory. If you wish to store more images in a limited amount of memory, use a lower image size.
[]	Image Quality	[★★] Fine [★] Normal	Sets the quality (compression rate) at which the image is captured.
[]	AF Area	[] Spot [] Multi	Determines how the focus area is selected.
[]	Interval Shoot		Captures images according to the settings specified. For details, see 3.1.11.2 "Using the Interval Shoot" on page 12.
[]	Date Stamp	[ON] [OFF]	Prints the current date on the bottom right corner of images captured. This function must be activated before the image is captured. For more information on setting the date and time or the date format, refer to the table of 3.4 "Setup Mode" on page 19.
[]	White Balance (Only available in Manual mode)	[] Auto WB [] Sunny [] Cloudy [] Tungsten [] Fluorescent	Sets the white balance when capturing images under specific lighting conditions. <ul style="list-style-type: none"> - Auto WB: Automatically adjust the white balance. - Sunny: Suitable for bright daylight conditions. - Cloudy: Suitable for cloudy, twilight, or shady conditions. - Tungsten: Suitable for subjects lit by tungsten (incandescent) lighting. - Fluorescent: Suitable for subjects lit by fluorescent lighting.

English

Icon	Item	Option	Functional Description
	Metering (Only available in Manual mode)	 Center Avg.  Spot  Average	Adjusts the region of the subject or frame on which the camera measures light. <ul style="list-style-type: none"> Center Avg.: The camera metering is set for the average brightness of objects in the center region of the frame. Spot: The camera metering is set for the brightness of the object at the center of the frame. Average: The camera metering is set for the average brightness of all objects in the frame.
	Effect	 Normal  B & W  Sepia  Vivid	Applies a tone or color to your pictures to create an artistic effect. <ul style="list-style-type: none"> Normal: Standard RGB color settings suitable for general photography. B & W: Black and white pictures with shades of grey. Sepia: Produces a warm, old-fashioned style of pictures, in which the colors are more brown and orange. Vivid: Produces sharper and more vibrant colors.
	ISO (Only available in Manual mode)	 ISO Auto  ISO 100  ISO 200  ISO 400	Configures the camera's sensitivity to light. <ul style="list-style-type: none"> ISO Auto: Automatically sets the ISO value. ISO 100: Equivalent to color ISO 100 film. Use for outdoor photography in bright sunlight. ISO 200: Equivalent to color ISO 200 film. Use for outdoor or brightly lit indoor photography. ISO 400: Equivalent to color ISO 400 film. Use for fast-moving subjects.



• **Setting the White Balance**

The human eye adapts to changes in light so that white objects still appear white even when the light changes. With a digital camera, however, the color of the subject is influenced by the color of the light surrounding it. This color adjustment is called "white balance adjustment". This setting allows you to set the white balance when capturing images under specific lighting conditions.

3.1.11.2 Using the Interval Shoot

The camera provides interval image capturing based on the setting. This mode is available in the self-timer photography. You may specify the interval and counts of images captured.

To adjust Interval Shoot settings:

- In Snapshot Mode, select Interval Shoot menu.
- Use the []/[] buttons to toggle between Interval and Count, and then press the **OK** button.
 - Interval:
 - [15 sec.]: The recording interval is 15 seconds.
 - [1 min.]: The recording interval is 1 minute.
 - [3 min.]: The recording interval is 3 minutes.
 - [10 min.]: The recording interval is 10 minutes.
 - [60 min.]: The recording interval is 60 minutes.
 - Count: 2 ~ 99 counts (specifying how many shots can be taken).



3. Use the []/[] buttons to adjust the settings, and then press the **OK** button.

To capture images with Interval Shoot function:

1. In Snapshot Mode, toggle the [] button to select Interval Shoot mode.
2. Press the shutter button to start. Images will be captured according to the preset Interval and Count.
3. If you wish to stop, press the shutter button.

3.2 Movie Mode

With the specially designed pause function of the camera, you can pause your recording session whenever you want to best suit your need. Experience this feature with the following easy steps.

1. Toggle the [] button to enter Movie Mode. The video clip recording screen is displayed.
 2. Frame the subject in the LCD screen with the zoom button, if desired.
 - Optical zoom should be set before recording.
 - Optical zoom cannot be used during recording.
 3. Press the shutter button to start recording.
 - To stop the recording session, press the shutter button again.
 - To pause the recording session, press the **OK** button. To resume, press the **OK** button again.
- **The flash cannot be used in Movie Mode.**
 - **EV compensation cannot be set or activated in Movie Mode.**
 - **While a video is being recorded to an SD memory card, neither open the battery/SD memory card cover, nor remove the battery/SD memory card. Doing so might damage the SD memory card or destroy the data.**
 - **The length of the recording depends on the remaining capacity of your memory card or the camera's built-in memory. The remaining time is displayed on the upper right corner of the LCD monitor.**

3.2.1 Movie Mode LCD Monitor Information

1. Movie Mode
2. Available recording time
3. Movie Quality
4. Zoom status
5. Battery power level indicator

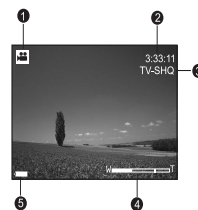

3.2.2 Movie Mode Menu Settings

3.2.2.1 Movie Mode Menu

1. In Movie Mode, press the [MENU] button to access the menu, and then use the [OK]/[EXIT] buttons to select the menu settings you want to change.
2. Use the [UP]/[DOWN] buttons to select the desired item in the menu, and then press the OK button.
3. To exit from the menu, press the [MENU] button.



Icon	Item	Option	Functional Description
[Movie Quality Icon]	Movie Quality	<ul style="list-style-type: none"> [TV-SHQ] TV-SHQ [TV-HQ] TV-HQ [TV-S] TV-S [Web-HQ] Web-HQ [Web-S] Web-S 	<p>Sets the quality and size of the video clip that will be recorded.</p> <ul style="list-style-type: none"> - TV-SHQ: 640 x 480 Fine - TV-HQ: 640 x 480 - TV-S: 320 x 240 Fine - Web-HQ: 320 x 240 - Web-S: 160 x 128 <p>☞ "SHQ" refers to "super high quality". "HQ" refers to "high quality". "S" refers to "standard".</p>
[White Balance Icon]	White Balance	<ul style="list-style-type: none"> [Auto WB] Auto WB [Sunny] Sunny [Cloudy] Cloudy [Tungsten] Tungsten [Fluorescent] Fluorescent 	<p>Sets the white balance when recording subjects under specific lighting conditions.</p> <ul style="list-style-type: none"> - Auto WB: Automatically adjust the white balance. - Sunny: Suitable for bright daylight conditions. - Cloudy: Suitable for cloudy, twilight, or shady conditions. - Tungsten: Suitable for subjects lit by tungsten (incandescent) lighting. - Fluorescent: Suitable for subjects lit by fluorescent lighting.
[Effect Icon]	Effect	<ul style="list-style-type: none"> [Normal] Normal [B & W] B & W [Sepia] Sepia [Vivid] Vivid 	<p>Sets the color of the video clip that will be recorded.</p> <ul style="list-style-type: none"> - Normal: Standard RGB color settings suitable for general recording. - B & W: Black and white video clips with shades of grey. - Sepia: Produces a warm, old-fashioned style of video clips, in which the colors are more brown and orange. - Vivid: Produces sharper and more vibrant colors.
[Timer REC Icon]	Timer REC	[SET] Set	<p>Allows you to set recording session in advance. For more information on setting Timer Recording, refer to 3.2.3 "Timer Recording" on page 15.</p>

	Stabilizer	[ON] On [OFF] Off	Prevents the shaking and enhances the quality and clarity of the video clips.
---	------------	--------------------------	---

English

3.2.3 Timer Recording

With the special “Timer Recording” feature, you can set recording session in advance, by following the steps below.

- In Movie Mode, press the [MENU] button to access the menu, and then scroll to [Timer REC].
- Press [SET].
The [Timer recording setting] screen is displayed.
- Press the []/[] buttons to set each item. Press the []/[] buttons to move to the next item.
- After you set the Start Time and Duration, press the **OK** button to confirm.
- The [Timer Recording Standby] screen is displayed. You can press the zoom key to adjust the distance.
 - To activate the setting, press the shutter.
 - To exit, press the [] button.
- The [Timer Recording] screen is displayed. The camera enters the Standby mode and shows the information of your session. If you wish to cancel the action, press the shutter.
- When the recording session begins, the camera enters the Recording mode. After the recording session is complete, the camera will power off automatically.



3.3 Playback Mode

In Playback Mode, you can view, magnify, resize, trim, delete images, play video clips, record a voice memo, or run a slide show. This mode also provides a thumbnail image display, allowing you to quickly search for the desired image.

- Press the [] button to enter Playback Mode.
- Use the []/[] buttons to select the desired images.
 - To view the previous image, press the [] button.
 - To view the next image, press the [] button.



3.3.1 Playback Mode LCD Monitor Information (Image)

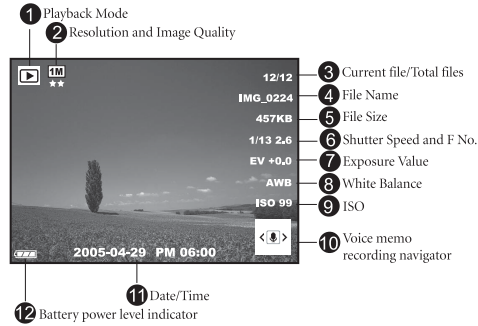

3.3.2 Viewing Images

3.3.2.1 Magnifying Images

While reviewing your images, you may enlarge a selected portion of an image. This magnification allows you to view the details of the image. The camera provides 4X magnification during playback.

1. Set the zoom ratio by adjusting the zoom key.
 - To zoom in, adjust the zoom key to the right.
 - To zoom out, adjust the zoom key to the left.
 - The magnification factor is displayed on the LCD monitor.

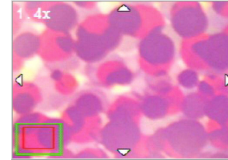

2. To view a different portion of the images, press the [ZOOM] / [RECALL] / [W/PHOTO] / [ZOOM] buttons to adjust the display area.





You will see a frame with a square box inside. The frame indicates the entire image, while the square box shows the location of the currently enlarged area.

3. To return to the regular display, adjust the zoom key to the left until the normal image (1X magnification) appears on the screen. Or, you can press the [MENU] button to exit directly.

- If there is no image stored in the internal memory or memory card, a [No File!] message will appear on the LCD monitor.
- Pressing the [MENU] button while playing back images changes the LCD display in the sequence of: OSD Normal → Detailed Info. → Info. Off.

3.3.2.2 Thumbnail Display (Index Playback)

This function allows you to view nine thumbnail images on the LCD monitor simultaneously, so that you can search for the image you need easily.



1. Adjust the zoom key to the left.
Nine thumbnail images are displayed simultaneously.
2. Use the []/[]/[]/[] buttons to select the image to be displayed at the regular size, and then press the **OK** button to display the selected image in the full screen mode.



English

3.3.2.3 Voice Memo

Adding a voice memo is a useful way of adding notes and reminders to images.

1. In Playback Mode, select an image. The [] icon is displayed on the bottom right corner of the LCD monitor.
2. Press the **OK** button to start recording. The time elapsed is displayed on the LCD monitor. You are allowed to add a voice memo up to 20 seconds for each image.
3. Press the **OK** button again to stop recording.
4. Press the **OK** button again to play the voice memo.
5. If you wish to remove the voice memo, press the [] button, choose [Delete Voice], and then press the **OK** button.

3.3.3 Deleting Files







When you are not satisfied with the images, video clips or voice memos, you can choose to delete them one by one or all at once. Please note that the deleted files cannot be recovered.

1. In Playback Mode, press the [] button to delete files.
 - To delete the current unwanted file, choose [Delete One] and press the **OK** button.
 - To delete all the files, choose [Delete All] and press the **OK** button.
 - To delete an image which contains a voice memo, choose [Delete Voice] and press the **OK** button.
 - To cancel the action, choose [Exit].





















 **Protected files cannot be deleted.**

3.3.4 Playback Mode Menu Settings

3.3.4.1 Playback Mode Menu

1. Press the [] button to enter Playback Mode.
2. Press the [] button to access the menu, and then use the []/[] buttons to select the menu settings you want to change.
3. Use the []/[] buttons to select the desired item in the menu, and then press the **OK** button.

4. To exit from the menu, press the [MENU] button.

Icon	Item	Option	Functional Description
[]	Protect	[SET]	<p>Sets the files to the read-only status to prevent them from being erased by mistake.</p> <p>To protect your files, follow the steps below.</p> <ol style="list-style-type: none"> 1. Press [SET] when the [Protect] menu is displayed. 2. You can choose to protect or unprotect the files as follows. <ul style="list-style-type: none"> - Choose [Protect One] and press the OK button to protect the current selected file. If you wish to cancel protecting the current file, choose [Unprotect One] and press the OK button. - Choose [Protect All] and press the OK button to protect all the files. If you wish to cancel protecting all the files, choose [Unprotect All] and press the OK button. - To quit the menu, press [Exit]. <p> An  icon will be displayed if the file is protected.</p>
[]	Trim	[SET]	<p>Allows you to trim a portion of a captured image.</p> <p>To trim a captured image, follow the steps below.</p> <ol style="list-style-type: none"> 1. In Playback Mode, choose Trim and then press [SET]. 2. Use the zoom key and []/[]/[]/[]/[] buttons to move to the portion you want. 3. Press the OK button. <p> A trimmed image will be saved as another file and has a smaller size.</p>
[]	Slideshow	[] 1 sec. [] 3 sec. [] 5 sec.	<p>This function enables you to set the time interval while playing back your images automatically in sequential order as a slide show. This is a very useful and entertaining feature for reviewing captured images and for presentations.</p> <p>Once you select an option, the slideshow will begin immediately. If you wish to stop, just press the OK button.</p>
[]	Resize	[] 2048 x 1536 [] 1600 x 1200 [] 1280 x 960 [] 640 x 480	<p>Allows you to change the size of a captured image.</p> <p>To resize a captured image, follow the steps below.</p> <ol style="list-style-type: none"> 1. In Playback Mode, choose Resize and then select the desired option. 2. Press the OK button. <p> A resized image will be saved as another file and has a smaller size.</p>

3.3.5 Playback Mode LCD Monitor Information (Video)





1. Playback Mode
2. Current file/Total files
3. File Name
4. File Size
5. Playback navigator
6. Date/Time
7. Battery power level indicator



English

3.3.6 Playing Back Video Clips

In Playback Mode, use the playback navigator  on the bottom right corner of the LCD monitor to control the playback of video clips.

- Press the **OK** button to start playing back a video clip.
 - To pause or resume the video playback, press the **OK** button.
 - To stop the video playback, press the [] button.
 - To play back the video clip with slow motion, press the [] button.
 - To start the fast forward video playback, press the [] button.
 - To start the fast reverse video playback, press the [] button.
-  • **The zoom function cannot be activated while playing back video clips.**

3.4 Setup Mode







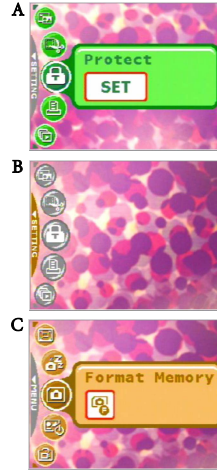







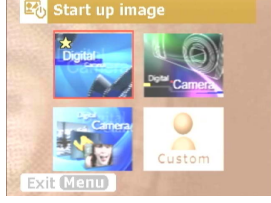

Whatever mode you are currently using, Setup Mode can always be accessed. Select your preferences for the camera with this mode.



























3.4.1 Setup Mode Menu

1. In whichever mode (Snapshot Mode, Movie Mode, or Playback Mode), press the [MENU] button (Step **A**).
2. Press the [OK] button **twice** to enter Setup Mode (Step **B** and Step **C**).
3. Use the [Left]/[Right] buttons to select the menu settings you want to change.
4. Use the [Up]/[Down] buttons to select the desired item in the menu, and then press the **OK** button.
5. To exit from the menu, press the [OK] button **twice**.



Icon	Item	Option	Functional Description
[Memory Icon]	Memory	[Format Memory Icon] Format Memory	- [Format Memory]: This option is displayed when there is no SD memory card loaded. It erases all data and reformats the internal memory. Protected files are also erased.
[Memory Icon]	Memory	[Copy to Card Icon] Copy to Card [Format Card Icon] Format Card	- [Copy to Card]: This option is displayed when there is an SD memory card loaded. You may copy files from the camera's internal memory to a loaded SD memory card. - [Format Card]: This option is displayed when there is an SD memory card loaded. It erases all the data on the SD memory card and reformats the card. Protected files are also erased. An SD memory card cannot be formatted if it is write-protected. ☞ This menu is only available when an SD memory card has been inserted.

Icon	Item	Option	Functional Description
	Startup Image	[SET]	<p>To set a startup image that is displayed every time you power on the camera, follow the steps below.</p> <ol style="list-style-type: none"> 1. Select [SET], and then you will be prompted to select a startup image. Use the []/[]/[]/[]/[] buttons to select the image you prefer.  <ol style="list-style-type: none"> 2. If you are not satisfied with the pre-installed images, you may move to the bottom right corner of the LCD monitor to customize your startup image by selecting the images you like. 3. After the selection is done, press the OK button to confirm, and then press the [MENU] to exit.
	Power Save	[OFF] [30s] [1min] [3min]	<p>If the camera is idle for a certain period of time while the camera is powered on, it will switch to power-saving state according to your settings. If the camera is in power-saving state, re-activate it by pressing any button.</p> <ul style="list-style-type: none"> - Off/30 sec./1 min./3 min. <p> If the camera is idle for 5 minutes, the camera will power off automatically.</p>
	QuickView	[ON] [OFF]	<p>Allows you to get a quick preview immediately after an image is captured. The preview shows briefly and then you may continue to capture the next image.</p> <ul style="list-style-type: none"> - On/Off
	Digital Zoom	[ON] [OFF]	<p>Allows you to activate or deactivate Digital Zoom according to your preferences.</p> <ul style="list-style-type: none"> - On/Off
	Volume		<p>Allows you to adjust the volume of the video clips or voice memos. You may set the volume level with the []/[] buttons.</p>
	System Sound	[ON] [OFF]	<p>Allows you to toggle system sound effects on or off, such as the beep when pressing or scrolling.</p>

Icon	Item	Option	Functional Description
	Power On	 	Allows you to activate or deactivate the function of powering up from Inst. REC and Inst. Play buttons. [On]: enables the function of powering up the camera from the Inst. REC and Inst. Play buttons. [Off]: disables the function of powering up the camera from Inst. REC and Inst. Play buttons.
	LCD Brightness	 Normal  Bright	Allows you to set the brightness of the LCD monitor to Normal or Bright.
	Date/Time		Allows you to adjust the camera's date and time. 1. Use the  /  buttons to select the item you want to change. 2. Press the OK button and then use the  /  buttons to adjust the setting. Setting the date and time is important as the information is stored with the images you take, and is used if you have turned on Date Stamp. Set the date and time before using the camera for the first time.
	Date Format	  	Allows you to select the date format used for the [Date Stamp] feature. -  Year - Month - Date -  Month - Date - Year -  Date - Month - Year
	Video Out	 	The camera's TV out port provides video output for viewing images or video clips on a standard TV screen. Set the video output mode to either NTSC or PAL. Refer to your local authorities for information on whether NTSC or PAL is used in your country/region.
	Language		Allows you to set the language that is displayed on the LCD monitor.
	Reset	 File No. Reset  Default	<ul style="list-style-type: none"> [File No. Reset]: The camera automatically assigns incrementing numbers to the file names of all images, video clips, and voice memos that you record. You can choose to reset the auto numbering to start from 1. [Default]: Selecting this function returns all camera settings back to factory preset values.
	Firmware Ver.		Displays the installed firmware version number.



4 PC DEPENDENT FEATURES

4.1 Bundled Software

The camera is supplied with the following software. To install the software, refer to the information supplied with respective CDs.

Ulead Photo Express

Ulead® Photo Express™ 5.0 SE is a complete photo project software for digital images. Acquire photos effortlessly from digital cameras or scanners. Edit and enhance images using easy-to-use editing tools and cool photographic filters and effects. Assemble creative photo projects and share results via e-mail and multiple print options.

Ulead Photo Explorer

Ulead® Photo Explorer™ 8.0 SE Basic provides an efficient way to transfer, browse, modify and distribute digital media. It is an all-in-one tool for owners of digital cameras, webcams, DV camcorders, scanners, or for anyone who strives to effectively handle digital media.

Ulead VideoStudio

Ulead® VideoStudio™ 8 SE VCD is home video editing software that makes editing movies as fun as shooting them. Users can make a movie in three easy steps using the new Movie Wizard mode. Share finished projects on VCD, tape, the web, and mobile devices.

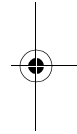
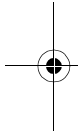

English



4.2 USB Mode

1. Connect the end of the smaller plug of the USB cable to the camera.
2. Connect the other end of the USB cable to an available USB port on your computer.
3. Turn on the camera.
The USB screen is displayed.
4. A "Removable Disk" icon appears in "My Computer."
Click this icon to access your images or video clips.

- **When connecting to a computer, it is necessary to install a battery.**



4.3 Printer Mode

If a printer that supports PictBridge is available, images can be printed without using a computer by connecting the camera directly to a PictBridge compliant printer.

Connecting the Camera to a PictBridge compliant Printer

1. Connect the camera to the printer with the included USB cable, and then turn on the camera.
2. Select [Printer].
- **If no selection is made within 10 seconds, [Mass Storage] (e.g. external hard disk) is activated instead.**
3. When the connection is established, you will be asked to select [Print One], [Print All], or [Print Index]. Select the desired option and then press the OK button.
4. [Setup], [Print], and [Exit] options will be displayed on the bottom of the LCD monitor.
 - If you select [Setup], [Pictbridge setup] screen will be displayed. You may set [Copies], [Size], and [Quality], if desired.
 - If you are satisfied with the settings, select [Print] to proceed.
 - If you want to cancel, select [Exit].
- **The functions described above may differ due to the design of the printer you connect to.**



5 TROUBLESHOOTING

Refer to the symptoms and solutions listed below before shipping your camera for service. If the problem persists, contact your local reseller or service center.

Symptom	Cause	Solution
The camera cannot be powered up.	There is no battery or the battery is not inserted correctly.	Insert the battery correctly.
	The battery has no power.	Recharge the battery.
The battery power is draining quickly.	The external temperature is extremely low.	—
	Many shots are being captured in dark places, requiring a flash.	—
	The battery was not fully charged. The battery has not been used for an extended period of time after being charged.	Fully charge the battery and discharge it for at least one complete cycle before use.
The battery or camera is warm.	The camera or flash was used continuously over a long period of time.	—
The flash does not fire. The flash does not recharge.	The camera flash is turned off.	Set the flash to Auto Flash.
	The light source is sufficient.	—
Even though the flash fired, the image is dark.	The distance to the subject is greater than the flash's effective range.	Get closer to the subject and shoot.
The image is too bright or too dark.	The exposure is excessive or inadequate.	Reset exposure compensation.
I cannot format a memory card.	The memory card is write-protected.	Remove the write protection.
	End of the memory card life.	Insert a new memory card.
I cannot download images.	The free space on the hard disk of your computer is insufficient.	Ensure that the hard disk has enough space for running Windows and that the drive for loading image files has free space equal to or greater than the memory card in the camera.
	There is no power being supplied to the camera.	Recharge the battery.

English

English

Symptom	Cause	Solution
The camera does not shoot even when pressing the shutter button.	The battery is running low.	Recharge the battery.
	The camera is not in Shooting Mode.	Switch to Shooting Mode.
	The shutter button was not pressed all the way down.	Press the shutter button all the way down.
	The internal memory or memory card does not have any free space.	Load a new card or delete unwanted files.
	The flash is recharging.	Wait until the flash mode icon, indicated on the screen, stops flashing.
	The camera does not recognize the memory card.	Format the memory card before the initial use or before using with another camera.
I cannot print images with PictBridge compliant printers.	The camera is connected to the printer when the camera is powered off.	Please turn on the camera, select PictBridge and then connect to the printer.

6 SPECIFICATIONS

Image Sensor	1/2.5-inch CCD
	Effective Pixels: 6.19 Mega pixels
LCD Display	2.4 inch color LTPS LCD (480 x 234 pixels)
Lens	Focal Length: f = 5.8 - 17.4 mm (35 mm - 105 mm; 35 mm Equivalent)
	F No.: F2.8/F4.8
Focusing	TTL Auto Focus
	Range: Macro: 6 cm, Normal: 60 cm ~ infinity
Shutter	Mechanical shutter: Up to 1/2000 sec.
Shooting Mode	Auto/Manual/Portrait/Landscape/Night/Sport/Backlight/Night Scene Portrait
Flash	Modes: Auto/Forced flash/Red-eye reduction/Flash off/Slow Sync
	Range: 0.5 ~ 2.0m
Self-timer	10 sec, 2 sec
Exposure	Compensation: ± 2 EV (1/3 EV/step)
ISO	Auto/100/200/400
White Balance	Auto/Sunny/Cloudy/Sunset/Tungsten/Fluorescent
File Format	Still Image: JPEG format (EXIF2.2), DCF Image Size: 2816 x 2112, 2304 x 1728, 1600 x 1200, 1280 x 960, 640 x 480 pixels
	Movie Clips: Motion-JPEG AVI format with Continuous recording. Movie Size: 640 x 480, 320 x 240, 160 x 128 pixels (30 fps)
Storage	Built-in memory: 24MB/SD memory card compatible.
Image Play	Single image/AVI play/Thumbnails/Slide show
Interface	Digital output: USB
	Audio/Video output (NTSC/PAL)
Power Source	Rechargeable Lithium-ion Battery
Dimensions (W x H x D)	92 x 60 x 24.5 mm
Weight	Approx. 135+/-10 g (w/o battery, SD memory card)

System Requirements (For Windows)

* Pentium 166 Mhz or higher CPU	* Windows XP/ME/2000
* 64 MB RAM	* 128 MB free hard disk space
* CD-ROM drive	* Available USB port

English



Entretien de votre appareil photo

- Ne pas utiliser votre appareil photo dans les environnements suivants : Températures inférieures à 0 °C ou supérieures à 40 °C.
- Ne pas utiliser ni stocker votre appareil photo dans les environnements décrits ci-dessous :
 - Exposition directe au soleil.
 - Endroits très humides et poussiéreux.
 - A proximité d'appareils de conditionnement d'air, de chauffages électriques ou d'autres sources de chaleur.
 - Dans une voiture fermée directement exposée au soleil.
 - Emplacements susceptibles à des vibrations
- Si votre appareil photo venait à être mouillé, essuyez-le dès que possible avec un chiffon sec.
- Le sel de l'eau de mer risque d'endommager sévèrement l'appareil photo.
- Ne pas utiliser de dissolvants organiques tels que de l'alcool, etc. pour nettoyer votre appareil photo.
- Si l'objectif du viseur est sale, veuillez utiliser une brosse à objectif ou un chiffon doux pour nettoyer l'objectif. Ne pas toucher l'objectif avec vos doigts.
- Afin d'éviter tout risque d'électrocution, ne tentez pas de démonter ni de réparer l'appareil vous-même.
- L'eau risque de causer un incendie ou une électrocution.
- Ne pas utiliser votre appareil à l'extérieur s'il pleut ou s'il neige
- Ne pas utiliser votre appareil près de ou dans l'eau.
- Si une substance étrangère ou de l'eau pénètre dans l'appareil, veuillez l'éteindre immédiatement et enlever les piles. Enlevez les substances étrangères ou l'eau et envoyez l'appareil à un centre d'entretien.
- Transférez les données sur votre ordinateur dès que possible afin d'éviter tout risque de perte de vos données graphiques.

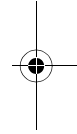
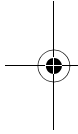
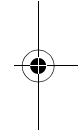
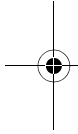

Table des matières

1. Présentation de votre Appareil Photo Numérique	1
1.1 Vérification du contenu du paquet.....	1
1.2 Composants de l'Appareil Photo Numérique	1
1.2.1 Vue avant	1
1.2.2 Vue arrière.....	2
1.2.3 Témoin DEL	2
2. Avant d'utiliser votre Appareil Photo Numérique	3
2.1 Installation de la batterie	3
2.2 Rechargement de la batterie	3
2.3 Insertion et Retrait d'une carte mémoire SD.....	4
2.4 Configuration de la Date et de l'Heure	4
3. Utiliser l'Appareil Photo Numérique	5
3.1 Mode Prise de Vue	5
3.1.1 Commencer à prendre des photos.....	5
3.1.2 Informations sur l'écran LCD en Mode Prise de Vue...	6
3.1.3 Réglage de l'appareil.....	7
3.1.4 Configurer le Mode Déclenchement.....	7
3.1.5 Utilisation du Flash	8
3.1.6 Utilisation du Retardateur	9
3.1.7 Utilisation du Zoom Optique.....	9
3.1.8 Utilisation du Zoom Numérique	10
3.1.9 Réglage de la Mise au Point.....	10
3.1.10 Réglage de l'EV	10
3.1.11 Menu des Réglages du Mode Prise de Vue	10
3.1.11.1 Menu du Mode Prise de Vue	10
3.1.11.2 Utilisation de la Prise de Vue à Intervalle.....	12
3.2 Mode Film	13
3.2.1 Informations sur l'Ecran LCD en Mode Film	13



Français



- 3.2.2 Menu des Réglages du Mode Film..... 14
 - 3.2.2.1 Menu Mode Film 14
- 3.2.3 Minuteur d'Enregistrement 15
- 3.3 Mode Visualisation..... 15
 - 3.3.1 Ecran LCD en Mode Visualisation
 - Informations (Photo) 16
 - 3.3.2 Visualisation des photos..... 16
 - 3.3.2.1 Agrandir des photos..... 16
 - 3.3.2.2 Affichage Miniatures(Visualisation par Index) .. 16
 - 3.3.2.3 Mémo Vocal..... 17
 - 3.3.3 Suppression des Fichiers..... 17
 - 3.3.4 Menu des Réglages du Mode Visualisation 17
 - 3.3.4.1 Menu du Mode Visualisation 17
 - 3.3.5 Informations sur l'Ecran LCD en Mode
 - Visualisation (Clips Vidéo) 19
 - 3.3.6 Lecture des clips vidéo 19
- 3.4 Mode Configuration..... 19
 - 3.4.1 Menu Mode Configuration..... 20
- 4. Fonctions Dependantes Du PC..... 23**
 - 4.1 Logiciel Fournis..... 23
 - 4.2 Mode USB..... 24
 - 4.3 Mode Impression 24
- 5. Dépannage..... 25**
- 6. Spécifications 27**

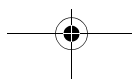

I PRÉSENTATION DE VOTRE APPAREIL PHOTO NUMÉRIQUE

1.1 Vérification du contenu du paquet

Ouvrez le paquet avec soin et vérifiez que les éléments suivants sont présents.

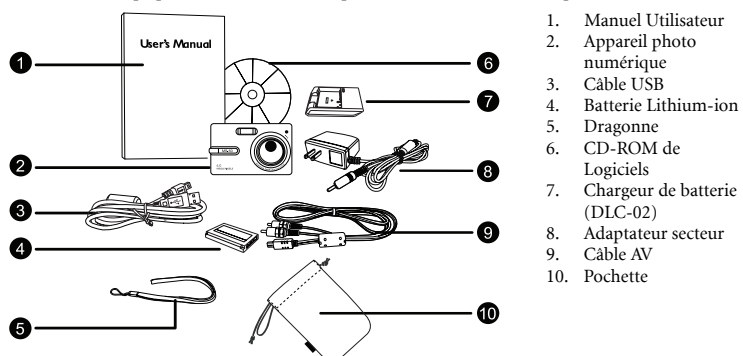

1. Manuel Utilisateur
2. Appareil photo numérique
3. Câble USB
4. Batterie Lithium-ion
5. Dragonne
6. CD-ROM de Logiciels
7. Chargeur de batterie (DLC-02)
8. Adaptateur secteur
9. Câble AV
10. Pochette

S'il manque un élément ou si un élément est endommagé, contactez votre revendeur. Conservez l'emballage pour les cas où vous devrez renvoyer votre appareil pour un dépannage.

1.2 Composants de l'Appareil Photo Numérique

1.2.1 Vue avant

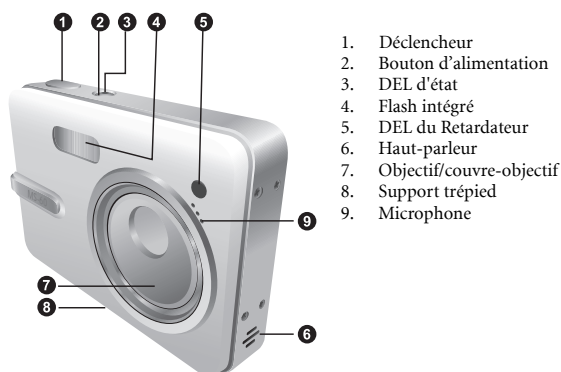

Français

1.2.2 Vue arrière

1. Ecran LCD
2. Bouton Lecture Inst.
3. Bouton ENR.
4. Oeillet pour dragonne
5. Port USB / AV
6. Bouton de Navigation à quatre directions et bouton **OK**
7. Bouton Menu
8. Bouton AFFICHAGE

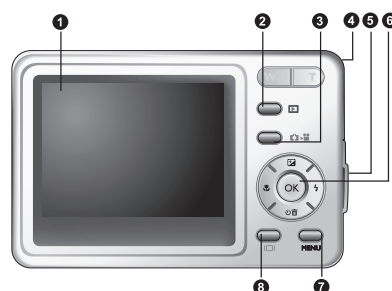

Français

1.2.3 Témoin DEL

Témoin	État	Description
DEL d'état	Allumé bleu	<ul style="list-style-type: none"> • L'appareil photo est allumé et prêt à être utilisé. • La connexion USB est en cours. • L'appareil photo est en mode d'économie d'énergie.
	Clignotant bleu	<ul style="list-style-type: none"> • L'appareil photo est en cours de traitement ou d'accès aux données.
	Clignotant orange	<ul style="list-style-type: none"> • Il y a des messages d'erreur ou d'avertissement.
DEL du Retardateur	Rouge fixe	<ul style="list-style-type: none"> • Les fonctions de l'enregistrement audio ou l'enregistrement film sont activées.
	Rouge clignotant	<ul style="list-style-type: none"> • Les fonctions du retardateur ou de la prise de vue par intervalle sont activées.

- L'écran LCD de l'appareil photo est fabriqué en utilisant une technologie sophistiquée; cependant il peut y avoir l'apparition des petits points ou de couleurs inhabituelles. Ceci est normal et n'indique pas un dysfonctionnement de l'écran, ce phénomène n'affecte non plus les photos que vous aurez prises avec l'appareil photo.

2 AVANT D'UTILISER VOTRE APPAREIL PHOTO NUMÉRIQUE

2.1 Installation de la batterie

Nous vous recommandons fortement d'utiliser uniquement la batterie rechargeable lithium-ion spécifiée avec votre appareil photo. Pour éviter de l'endommager, vérifiez que l'appareil est éteint avant d'insérer ou d'enlever la batterie.

Pour insérer la batterie :

1. Ouvrez le couvercle du compartiment batterie/carte mémoire SD (A).
2. Insérez la batterie dans la direction correcte indiquée (B).
3. Enfoncez la batterie au maximum jusqu'à ce que le levier de verrouillage de la batterie se mette en place (C).
4. Fermez le couvercle du compartiment batterie/carte mémoire SD (D).

Pour enlever la batterie :

1. Ouvrez le couvercle du compartiment batterie/carte mémoire SD.
2. Libérez le levier de verrouillage de la batterie.
3. Lorsque la batterie est légèrement sortie, retirez-la délicatement du compartiment.

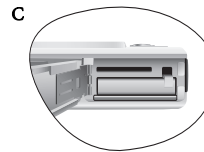
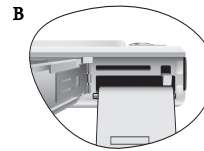

Français

2.2 Rechargement de la batterie

L'état de charge de la batterie affecte les performances de votre Appareil Photo Numérique. Pour optimiser les performances et la durée de vie de la batterie, nous vous recommandons, au moins une fois, de complètement la recharger à l'aide du chargeur spécifié (le chargeur et l'adaptateur secteur) puis de la décharger complètement avec une utilisation normale.

1. Insérez la batterie dans le chargeur comme indiqué sur l'illustration.
2. Connectez une extrémité de l'adaptateur secteur au chargeur.
3. Connectez l'autre extrémité de l'adaptateur secteur à une prise électrique.
La longueur du temps de chargement dépend de la température ambiante et de l'état de la batterie.
4. Lorsque la batterie est en cours de chargement, la DEL du chargeur s'allume en rouge.
Une fois que la batterie sera complètement rechargée, elle deviendra verte.
La longueur du temps de chargement dépend de la température ambiante et de l'état de la batterie.

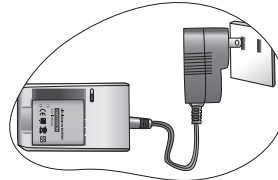

- ☞ **L'Appareil Photo Numérique doit être utilisé uniquement avec le chargeur spécifié. Les dommages causés par l'utilisation d'un adaptateur incorrect ne sont pas couverts par la garantie. Pour éviter de l'endommager, vérifiez que l'appareil est éteint avant d'enlever la batterie.**
- **La batterie peut être chaude après rechargement ou utilisation. Ceci est normal et ne constitue pas un dysfonctionnement.**
- **Lorsque vous utilisez l'appareil dans un environnement froid, conservez-le au chaud avec sa batterie en les maintenant sous votre manteau ou dans un autre endroit chaud.**

2.3 Insertion et Retrait d'une carte mémoire SD

Votre Appareil Photo Numérique est équipé d'une mémoire interne de 24MB, vous permettant d'enregistrer des clips vidéo, de prendre des photos ou d'enregistrer des fichiers vocaux dans l'appareil photo. Vous pouvez également augmenter la taille de la mémoire en ajoutant une carte mémoire SD (Secure Digital) optionnelle pour stocker plus de fichiers.

1. Pour éviter de l'endommager, vérifiez que l'appareil est éteint avant d'ajouter ou d'enlever une carte mémoire.
2. Insérez la carte mémoire SD dans la direction correcte indiquée sur l'illustration.
3. Refermez le couvercle du compartiment batterie/carte mémoire SD.
Pour enlever la carte mémoire SD, assurez-vous que l'appareil est bien hors tension. Appuyez légèrement sur le côté de la carte mémoire et elle sera éjectée.

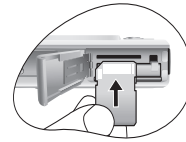

- ☞ **Assurez-vous de bien formater la carte mémoire SD sur cet appareil avant la première utilisation.**
- **Pour éviter tout effacement accidentel de données importantes stockées sur une carte mémoire SD, vous pouvez faire glisser la languette de protection en écriture (sur le côté de la carte mémoire SD) sur "VERROUILLER".**
- **Pour enregistrer, éditer ou effacer des données sur la carte mémoire SD, vous devez déverrouiller la carte.**
- **Pendant le formatage de la mémoire interne, veuillez ne pas insérer de carte mémoire dans l'appareil. Dans le cas contraire, la carte mémoire sera formatée à la place de la mémoire interne de l'appareil.**
- **Le formatage est irréversible et les données ne pourront plus être récupérées après un formatage. Faites une copie de sauvegarde de vos données avant tout formatage.**
- **Une carte mémoire SD possédant des problèmes de lecture ou d'écriture peut ne pas être correctement formatée.**
- **Les cartes mémoires SD suivantes sont supportées : 8 Mo, 16 Mo, 32 Mo, 64 Mo, 128 Mo, 256 Mo, 512 Mo et 1 Go. L'appareil photo est compatible avec les cartes mémoires SD de Panasonic, Toshiba et Sandisk. Veuillez contacter votre revendeur local si vous désirez acheter ces cartes.**

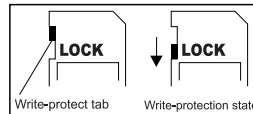

2.4 Configuration de la Date et de l'Heure

Avant d'utiliser votre appareil pour la première fois, veuillez régler la date et l'heure. Pour de plus amples informations, veuillez vous référer au tableau dans 3.4.1 "Menu Mode Configuration" en page 20.

UTILISER L'APPAREIL PHOTO NUMÉRIQUE

3.1 Mode Prise de Vue

3.1.1 Commencer à prendre des photos

1. Pressez le bouton [] pour allumer l'appareil photo.
2. Cadrez votre photo à l'aide de l'écran LCD dans le Mode Prise de Vue.
3. Pressez le déclencheur à mi-course (1), puis enfoncez-le complètement (2).

① Presser à mi-course



② Presser complètement



- Lorsque vous appuyez sur le déclencheur à mi-course, l'appareil effectue automatiquement la mise au point et choisit l'exposition.
 - Le cadre de la zone de mise au point devient vert lorsque ces réglages automatiques ont été faits.
 - Si la mise au point ou l'exposition n'est pas appropriée, le cadre de mise au point devient rouge.
- ☞ Pour afficher la dernière photo prise, pressez le bouton []. Pressez le bouton [] pour revenir au Mode Prise de Vue.
- L'image sur l'écran LCD s'obscurcit en cas de lumière forte ou trop lumineuse. Il ne s'agit pas d'un dysfonctionnement.
 - Pour éviter que les photos ne soient floues lorsque vous pressez sur le déclencheur, maintenez toujours l'appareil photo stable. Ceci est particulièrement important lorsque vous prenez des photos dans des endroits sombres ; dans de telles circonstances, l'appareil doit ralentir la vitesse du déclencheur de façon à obtenir une bonne exposition.
 - Presser le bouton [] permet de modifier les affichages sur l'écran dans l'ordre suivant : Normal OSD → Infos Détaillées. → Arrêt Infos
 - Si la fonction QuickView[Aperçu] est réglée sur « Marche », la dernière photo s'affichera sur l'écran pendant que l'appareil l'enregistre en mémoire.

Français

3.1.2 Informations sur l'écran LCD en Mode Prise de Vue

-
1. Mode Photo
 - [A] Auto
 - [M] Manuel
 - [P] Portrait
 - [L] Paysage
 - [N] Scène nuit
 - [S] Sport
 - [A] Rétrocl.
 - [P] Portrait de nuit
 2. Mode Flash
 - [Flash] Flash Auto
 - [Flash] Flash Marche
 - [Flash] Flash Arrêté
 - [Yeux] Yeux Rouge
 - [Sync] Sync. Lente
 3. Icône Retardateur (si activé)
 - [2s] Retardateur (2s)
 - [10s] Retardateur (10s)
 - [Interval] Intervalle de Prise de Vue
 4. Bal. blanc (si sélection de l'affichage [Infos Détaillées])
 - [Auto] Auto
 - [Ensoleillé] Ensoleillé
 - [Nuageux] Nuageux
 - [Tungstène] Tungstène
 - [Fluorescent] Fluorescent
 5. EV (Valeur d'Exposition)
 - 0.3, -0.6, -1.0, -1.3, -1.6, -2.0, +0.3, +0.6, +1.0, +1.3, +1.6, +2.0
 6. ISO
 - [Auto] ISO Auto
 - [100] ISO 100
 - [200] ISO 200
 - [400] ISO 400
 7. Métrage
 - [Moyenne] Moyenne Centrée
 - [Spot] Spot
 - [Moyenne] Moyenne
 8. Qualité
 - [Fin] Fin
 - [Normal] Normal
 9. Résolution (Taille Image)
 - [6M] 2816 x 2112
 - [4M] 2304 x 1728
 - [2M] 1600 x 1200
 - [1M] 1280 x 960
 - [VGA] 640 x 480
 10. Nombre de photos possibles
 11. Etat du zoom
 12. Zone AF
 13. Indicateur du niveau de la batterie
 - [Batterie pleine] Batterie pleine
 - [Batterie moyenne] Batterie moyenne
 - [Batterie faible] Batterie faible
 - [Batterie vide] Batterie vide

3.1.3 Réglage de l'appareil

Les paramétrages de l'Appareil Photo peuvent être modifiés avec les boutons à 4 directions et le bouton **OK**.

1. **Haut/EV:**
 - Déplace vers le haut dans les menus.
 - Vous permet de régler les paramètres EV.
2. **Gauche/Mise au Point:**
 - Déplace vers la gauche dans les menus.
 - Vous permet de choisir les paramètres de mise au point appropriés.
3. **Bas/Retardateur/Photo à intervalle/Supprimer**
 - Déplace vers le bas dans les menus.
 - Sélectionne les paramètres du retardateur.
 - Active les fonctions Photo à Intervalle.
 - Supprime des photos, des clips vidéo ou des mémos vocaux.
4. **Droite/ Flash:**
 - Déplace vers la droite dans les menus.
 - Vous permet de choisir les paramètres de flash appropriés.
5. **OK:** Pour valider un réglage.

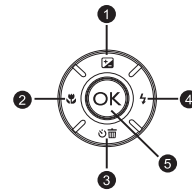

3.1.4 Configurer le Mode Déclenchement

Vous pouvez régler le Mode de Déclenchement pour faire des photos en respectant les étapes suivantes.

1. En mode de Déclenchement, pressez le bouton [**MENU**]. Le Menu Mode de Déclenchement est affiché.
 2. Utilisez les boutons [**↑**]/[**←**] pour choisir le mode désiré puis pressez le bouton **OK** pour confirmer.
- Le tableau ci-dessous vous aidera à choisir le Mode de Déclenchement approprié :



Icône	Mode de Déclenchement	Description
[A]	Auto	Sélectionnez ce mode lorsque vous désirez permettre à l'appareil de choisir automatiquement les réglages les plus appropriés.
[M]	Manuel	Sélectionnez ce mode lorsque vous voulez régler les paramètres de la Balance des Blancs, la Mesure et l'ISO. Ces menus sont disponibles uniquement en Mode Manuel.
[P]	Portrait	Sélectionnez ce mode lorsque vous voulez prendre une photo en faisant ressortir le sujet sur un fond flou. Le flash est réglé sur [☺], ce qui permet de réduire le phénomène des yeux rouges.
[L]	Paysage	Sélectionnez ce mode pour améliorer la saturation des couleurs pour les photos en montagne, en forêt ou dans d'autres paysages ou lorsque vous prenez des portraits avec des paysages en arrière-plan. Le flash est réglé sur [☺].
[N]	Scène nuit	Sélectionnez ce mode pour prendre des photos de personnes avec un arrière-plan de type coucher de soleil ou nuit. Le flash est réglé sur [☺].

Icône	Mode de Déclenchement	Description
	Sport	Sélectionnez ce mode pour prendre des photos de sujets se déplaçant rapidement. Le flash est réglé sur .
	Rétroécl.	Sélectionnez ce mode lorsque vous prenez des photos et que la lumière provient de derrière le sujet de la photo. Le flash est réglé sur .
	Portait de nuit	Choisissez ce mode pour mettre en évidence le sujet sur le fond de la photo. Le flash est automatiquement activé dans ce mode.

- La description de chaque Mode de Déclenchement peut être utilisée comme un guide général à votre disposition. Réglez votre appareil photo numérique comme vous le désirez.
- Le Mode de Déclenchement peut être réglé uniquement en Mode de Prise de Vue.

3.1.5 Utilisation du Flash

Le flash a été conçu pour fonctionner automatiquement lorsque les conditions d'éclairage justifient son utilisation. Vous pouvez prendre une photo en utilisant un mode de flash adapté à votre situation. Si vous modifiez le mode de flash, l'appareil conservera le paramétrage même si l'appareil est éteint.

1. En Mode Prise de Vue, le Flash Auto est activé par défaut.
2. Utilisez le bouton pour sélectionner d'autres modes de flash, si besoin.
3. Composez votre photo puis appuyez sur le déclencheur.

Le tableau ci-dessous vous aidera à choisir le mode de flash approprié.



Icône	Flash	Description
	Flash Auto	Le flash se déclenche automatiquement en fonction des conditions de lumière ambiante.
	Flash Marche	Le flash est déclenché quelle que soit la luminosité ambiante. Sélectionnez ce mode pour prendre des photos avec fort contraste (en Rétroécl) et des ombres profondes.
	Flash Arrêté	Le flash ne se déclenche pas. Sélectionnez ce mode dans un endroit où les photographies avec un flash sont interdites ou lorsque la distance vous séparant du sujet est trop importante pour l'efficacité du flash.
	Yeux Rouges	Ce mode peut réduire le phénomène des yeux-rouges lorsque vous voulez obtenir des photos naturelles d'animaux et de personnes dans des conditions d'éclairage faible. Lorsque vous prenez des photos, le phénomène des yeux rouges peut être réduit en demandant au sujet de regarder directement vers l'objectif de l'appareil photo ou en se rapprochant du sujet autant que possible.
	Sync. Lente	Ce mode ouvre le déclencheur pour une période plus longue que la normale et déclenche le flash juste avant de le refermer. Sélectionnez ce mode pour éclairer un sujet au premier plan tout en permettant de photographier un arrière plan plus sombre. Ce mode est adapté à la photographie nocturne avec des personnes en arrière-plan.

- Le flash ne peut pas être utilisé avec le Mode Film.
- Si vous sélectionnez Sync. Lente, pour éviter les photos floues, il est recommandé d'utiliser un trépied et de photographier des sujets immobiles.

3.1.6 Utilisation du Retardateur

Le retardateur peut être utilisé dans le Mode Prise de Vue. Cette caractéristique est très utile pour les situations où vous voulez faire partie de la photo.

1. Fixez l'appareil sur un trépied ou placez-le sur une surface stable.
2. En Mode Prise de Vue, utilisez le bouton [] pour choisir le mode de retardateur désiré.

Icône	Retardateur	Description
[]	Retardateur (2s)	L'appareil prend une photo automatiquement après un délai de deux secondes.
[]	Retardateur (10s)	L'appareil prend une photo automatiquement après un délai de dix secondes.
[]	Intervalle	L'appareil photo prend automatiquement une photo à intervalle régulier jusqu'à ce que le support soit plein ou que la batterie soit vide.

3. Cadrez votre photo puis appuyez sur le déclencheur.

- Le retardateur est enclenché et l'état du compte à rebours s'affiche sur l'écran LCD.
- La DEL du retardateur clignote et la photo sera prise automatiquement lorsque la durée prédéfinie est écoulée.
- Pour annuler le retardateur à tout moment, appuyez sur le bouton [].



- **La configuration du retardateur est automatiquement désactivée après chaque photo prise.**

3.1.7 Utilisation du Zoom Optique

Le zoom vous permet de prendre des photos agrandies par un facteur atteignant jusqu'à 3 fois la taille normale ou de prendre des photos à grand angle en fonction de la distance vous séparant du sujet. Vous pouvez agrandir le centre de l'écran et prendre des photos en utilisant le zoom numérique.

1. Pressez le bouton [] pour accéder au Mode Prise de Vue ou au Mode Film.
2. Cadrez la photo en utilisant le bouton zoom.
 - Régler la touche en appuyant sur la droite avance vers le sujet et l'agrandit sur l'écran LCD.
 - Régler la touche vers la gauche définit une image en grand angle.
 - La position de l'objectif se modifie en fonction du réglage du zoom uniquement pour le réglage du zoom optique.
3. Pressez le déclencheur à mi-course pour que la mise au point de l'appareil s'ajuste automatiquement puis appuyez complètement pour prendre la photo.







- **La fonction zoom ne peut pas être utilisée lorsque vous prenez des clips vidéo. Réglez le zoom avant de débiter l'enregistrement.**

3.1.8 Utilisation du Zoom Numérique

Vous pouvez utiliser une combinaison du zoom optique 3x et du zoom numérique 4x pour prendre des photos avec un zoom de 12x au maximum. Le zoom numérique est une fonction très utile ; toutefois, plus l'image est agrandie (zoomée), plus elle devient pixelisée (granuleuse).

3.1.9 Réglage de la Mise au Point



1. En Mode Prise de Vue, utilisez le bouton [] pour choisir l'un des modes suivants.

Icône	Mise au Point	Description
	Normal (AF)	Mise au Point Auto Normale (50 cm à l'infini).
[]	Macro	Mise au Point Auto Macro (6 cm). Le flash est réglé sur [].
[]	Mise au Point Panoramique (PF)	Cette option peut diminuer la durée de mise au point et améliorer l'efficacité de la prise de vue. Elle vous permet de capturer plus facilement les sujets se déplaçant rapidement ou les sujets dans la pénombre. La distance du champ de focus dans le mode [PF] : -La distance du champ de focus sur les cotés extrêmes de la lentille de zoom : 1m ~ 5m -La distance du champ de focus sur les cotés au centre de la lentille de zoom : 1m ~ 4m -La distance du champ de focus dans le viseur de la lentille de zoom : 1m ~ 3m

2. Cadrez votre photo.
3. Pressez le déclencheur à mi-course puis pressez-le complètement.

3.1.10 Réglage de l'EV

L'EV (Valeur d'exposition) vous permet d'éclaircir ou d'assombrir une photo. Utilisez ce réglage lorsque la luminosité n'est pas équilibrée entre le sujet et l'arrière-plan, ou lorsque le sujet occupe uniquement une petite partie de la photographie.

1. En Mode Prise de Vue, assurez-vous que le Mode de Déclenchement est réglé sur [Auto] ou [Manuel]. Pour plus d'informations sur le Mode de Déclenchement, veuillez vous référer à 3.1.4 "Configurer le Mode Déclenchement" en page 7.
2. Appuyez sur le bouton []. La barre de réglage de l'EV sera affichée en bas de l'écran LCD.
3. Par défaut, l'EV est réglée sur 0. Elle peut être réglée entre -2.0 et +2.0.
 - Pour augmenter la correction EV, pressez le bouton [] puis pressez le bouton **OK**.
 - Pour diminuer la correction EV, pressez le [] puis pressez le bouton **OK**.

3.1.11 Menu des Réglages du Mode Prise de Vue















3.1.11.1 Menu du Mode Prise de Vue

1. En Mode Prise de Vue, pressez le bouton [MENU] pour accéder au menu, puis utilisez les boutons [OK] / [ESC] pour sélectionner les paramètres du Menu que vous souhaitez modifier.
2. Utilisez les boutons [↑] / [↓] pour choisir l'item désiré puis pressez le bouton OK pour confirmer.
3. Pour quitter le menu, pressez le bouton [MENU].



Icône	Paramètre	Option	Description des fonctions
[6M]	Résolution	[6M] 2816 x 2112 [4M] 2304 x 1728 [2M] 1600 x 1200 [1M] 1280 x 960 [VGA] 640 x 480	Permet de choisir la taille des photos que vous désirez prendre. ⚡ Des résolutions de photo plus élevées nécessitent plus de mémoire. Si vous souhaitez enregistrer plus de photos dans un espace mémoire limité, utilisez une taille d'image plus faible.
[★★]	Qualité	[★★] Fine [★] Normale	Permet de définir la qualité (le taux de compression) à laquelle la photo est enregistrée.
[AF]	Zone AF	[] Point [] Multi	Détermine comment la zone de mise au point est sélectionnée.
[]	Intervalle		Prend des photos en fonction des paramètres spécifiés. Pour les détails, voir 3.1.11.2 "Utilisation de la Prise de Vue à Intervalle" en page 12.
[]	Horodateur	[ON] [OFF]	Imprime la date courante dans l'angle en bas à droite des photos capturées. Cette fonction doit être activée avant de prendre la photo. Pour plus d'informations sur le réglage de la date et de l'heure ou sur le réglage du format de la date, veuillez vous référer au tableau 3.4 "Mode Configuration" en page 19.
[]	Balance des Blancs (Uniquement disponible en Mode Manuel)	[] Auto [] Ensoleillé [] Nuageux [] Tungstène [] Fluorescent	Permet de régler la balance des blancs lorsque vous prenez des photos sous des conditions d'éclairage spécifiques <ul style="list-style-type: none"> - Auto: Règle automatiquement la balance des blancs - Ensoleillé: Adapté à la lumière d'une journée ensoleillée. - Nuageux: Adapté aux conditions nuageuses, de crépuscule ou d'ombre. - Tungstène: Adapté aux sujets éclairés par des lumières incandescentes. - Fluorescent: Adapté aux sujets éclairés par des lumières fluorescentes.

Français

Icône	Paramètre	Option	Description des fonctions
	Métrage (Uniquement disponible en Mode Manuel)	 Moy. centre  Spot  Moyenne	Définit la zone du sujet ou du cadre sur laquelle l'appareil métrage la lumière. <ul style="list-style-type: none"> Moy. centre: La mesure de l'appareil photo est définie pour une luminosité moyenne des objets dans la zone centrale du cadre. Spot: La mesure de l'appareil photo est définie pour la luminosité de l'objet au centre du cadre. Moyenne: La mesure de l'appareil photo est définie pour la luminosité moyenne de tous les objets dans le cadre.
	Effet photo	 Normal  N & B  Sépia  Vif	Applique un ton ou une couleur à vos photos pour créer un effet artistique. <ul style="list-style-type: none"> Normal: Réglages des couleurs RVB Standard, adaptés aux photos classiques. N & B: Photos Noir et Blanc avec des dégradés de gris. Sépia: Produit un style de photo ancien et chaleureux dans lequel les couleurs tendent vers le marron et l'orange. Vif: Produit des couleurs plus précises et plus éclatantes.
	ISO (Uniquement disponible en Mode Manuel)	 ISO Auto  ISO 100  ISO 200  ISO 400	Règle la sensibilité de l'appareil photo à la lumière. <ul style="list-style-type: none"> Auto ISO: Règle automatiquement la valeur ISO. ISO 100: Equivalent à une pellicule couleur ISO 100. Utilisation pour les photographies en extérieur sous une lumière ensoleillée. ISO 200: Equivalent à une pellicule couleur ISO 200. Utilisation pour les photographies en extérieur ou les éclairages lumineux en intérieur. ISO 400: Equivalent à une pellicule couleur ISO 400. Utilisation pour les sujets en déplacement rapide.



- Réglage de la Balance des Blancs**
 L'œil humain s'adapte automatiquement et rapidement à l'éclairage ambiant, et donc les objets blancs apparaissent en blanc même lorsque la lumière change. Par contre, avec un appareil photo numérique, les couleurs du sujet dépendent des couleurs de l'éclairage ambiant. Le processus de réglage des couleurs blanches est donc appelé « la balance des blancs ». Ce paramètre vous permet de régler la balance des blancs lorsque vous prenez des photos sous des conditions d'éclairage spécifiques.

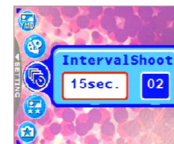

3.1.11.2 Utilisation de la Prise de Vue à Intervalle

L'appareil photo propose la capture de photos à intervalle régulier en se basant sur les réglages. Ce mode est disponible dans la photographie avec retardateur. Vous pouvez préciser l'intervalle et la quantité d'images capturées.



Pour régler les paramètres de l'intervalle des prises de vue:

- En Mode Prise de Vue, sélectionnez le menu Intervalle.
- Utilisez les boutons []/[] pour passer de Interval(Intervalle) à Count(Nombre) puis pressez le bouton **OK**.
 - Interval(Intervalle):
 - [15 sec.]: L'intervalle entre les prises de vue est de 15 secondes.
 - [1 min.]: L'intervalle entre les prises de vue est de 1 minute.
 - [3 min.]: L'intervalle entre les prises de vue est de 3 minutes.
 - [10 min.]: L'intervalle entre les prises de vue est de 10 minutes.
 - [60 min.]: L'intervalle entre les prises de vue est de 60 minutes.



- Count(Nombre): Nombre de 2 ~ 99 (définit combien de photos doivent être prises).
- Utilisez les boutons []/[] pour régler les paramètres puis pressez le bouton **OK**.

Pour prendre des photos avec la fonction Intervalle:

- En Mode Prise de Vue, utilisez le bouton [] pour sélectionner le mode Intervalle.
- Appuyez sur le déclencheur pour débuter. Les photos seront capturées en respectant l'Interval(Intervalle) et le Count(Nombre) prédéfinis.
- Si vous souhaitez arrêter, pressez le bouton déclencheur.

3.2 Mode Film

Avec la fonction pause de l'Appareil Photo Numérique conçue spécifiquement, vous pouvez mettre en pause votre session d'enregistrement chaque fois que vous le voulez en fonction de vos besoins. Expérimentez cette fonction avec les simples étapes suivantes.

- Utilisez le bouton [] pour passer en Mode Film. L'écran d'enregistrement d'un Clip vidéo est affiché.
 - Cadrez le sujet sur l'écran LCD avec le bouton zoom si besoin.
 - Le zoom optique doit être réglé avant l'enregistrement.
 - Le zoom optique ne peut pas être utilisé pendant l'enregistrement.
 - Appuyez sur le déclencheur pour commencer l'enregistrement.
 - Pour arrêter la session d'enregistrement, pressez de nouveau le bouton déclencheur.
 - Pour faire une pause pendant la session d'enregistrement, pressez le bouton **OK**. Pour reprendre, pressez de nouveau le bouton **OK**.
-  **Le flash ne peut pas être utilisé avec le Mode Film.**
-  **La compensation EV ne peut pas être réglée ou activée dans le Mode Film.**
- Pendant l'enregistrement d'une vidéo sur une carte mémoire SD, ne pas ouvrir le couvercle de la carte mémoire SD/de la batterie et ne pas retirer la batterie ou la carte mémoire SD. Ne pas respecter cette consigne peut endommager la mémoire SD ou détruire les données.**
- La durée de l'enregistrement dépend de la capacité mémoire disponible sur la carte mémoire ou dans la mémoire intégrée de l'appareil. La durée restante est affichée en haut à droite de l'écran LCD.**





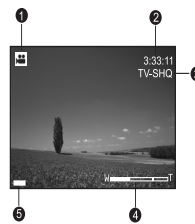

3.2.1 Informations sur l'Ecran LCD en Mode Film

- Mode Film
- Temps d'enregistrement disponible
- Qualité Film
- Etat du zoom
- Indicateur du niveau de la batterie

















3.2.2 Menu des Réglages du Mode Film

3.2.2.1 Menu Mode Film

1. En Mode Film, pressez le bouton [] pour accéder au menu, puis utilisez les boutons [] / [] pour sélectionner les paramètres du Menu que vous souhaitez modifier.
2. Utilisez les boutons [] / [] pour choisir l'item désiré puis pressez le bouton **OK** pour confirmer.
3. Appuyez sur le bouton [] pour quitter le menu.



Icône	Paramètre	Option	Description des fonctions
	Qualité Film	 TV-SHQ  TV-HQ  TV-S  Web-HQ  Web-S	Règle la qualité et la taille du clip vidéo qui sera enregistré. <ul style="list-style-type: none"> - TV-SHQ: 640 x 480 - TV-HQ: 640 x 480 - TV-S: 320 x 240 - Web-HQ: 320 x 240 - Web-S: 160 x 128 "SHQ" fait référence à "super haute qualité". "HQ" fait référence à "haute qualité". "S" fait référence à "standard".
	Bal. blanc	 BB Auto  Ensoleillé  Nuageux  Tungstène  Fluorescent	Permet de régler la balance des blancs lorsque vous enregistrez des sujets sous des conditions d'éclairage spécifiques. <ul style="list-style-type: none"> - BB Auto: Règle automatiquement la balance des blancs. - Ensoleillé: Adapté à la lumière d'une journée ensoleillée. - Nuageux: Adapté aux conditions nuageuses, de crépuscule ou d'ombre. - Tungstène: Adapté aux sujets éclairés par des lumières incandescentes. - Fluorescent: Adapté aux sujets éclairés par des lumières fluorescentes.
	Effet photo	<input checked="" type="checkbox"/> Normal <input type="checkbox"/> N & B <input type="checkbox"/> Sépia <input type="checkbox"/> Vif	Définit la couleur du clip vidéo qui va être enregistré. <ul style="list-style-type: none"> - Normal: Réglages des couleurs RVB Standard, adaptés aux enregistrements classiques. - N & B: Clips vidéo Noir et Blanc avec des dégradés de gris. - Sépia: Produit un style de clip vidéo ancien et chaleureux dans lequel les couleurs tendent vers le marron et l'orange. - Vif: Produit des couleurs plus précises et plus éclatantes.
	Temps ENR	 Régler	Vous permet de définir à l'avance la durée d'enregistrement de la session. Pour plus d'informations sur le minuteur d'enregistrement, veuillez vous référer à 3.2.3 "Minuteur d'Enregistrement" en page 15.

3.2.3 Minuteur d'Enregistrement

Grâce à la fonction spéciale de "Minuteur d'Enregistrement", vous pouvez définir à l'avance la durée d'enregistrement en suivant les étapes ci-dessous.

1. En Mode Film, pressez le bouton [MENU] pour accéder au Menu, puis déplacez-vous sur [Temps ENR].

2. Pressez [SET].

L'écran [Timer recording setting] (Paramètres du Minuteur d'Enregistrement) est affiché.

3. Pressez le bouton [OK] / [] pour régler chaque item.

Pressez [] / [] pour passer sur le prochain item.

4. Après avoir réglé l'Start Time (Heure de Début) et la Duratuo(n) (Durée), pressez le bouton OK pour confirmer.

5. L'écran [Timer Recording Standby] (Attente du Minuteur d'Enregistrement) est affiché. Vous pouvez presser la touche zoom pour régler la distance.

- Pour activer le réglage, pressez le déclencheur.
- pressez le bouton [] / [].

6. L'écran [Minuteur d'Enregistrement] est affiché. L'appareil entre dans le mode Attente et affiche les informations relatives à votre session. Si vous souhaitez annuler cette action, pressez le déclencheur.

7. Lorsque la session d'enregistrement débute, l'appareil photo passe en mode d'Enregistrement. Une fois la session d'enregistrement terminée, l'appareil photo s'arrêtera automatiquement.

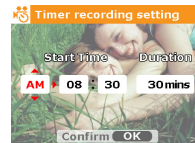

3.3 Mode Visualisation

En mode visualisation, vous pouvez afficher, agrandir, redimensionner, réduire ou supprimer des photos, enregistrer un mémo vocal ou lancer un diaporama. Ce mode vous permet également d'afficher des miniatures pour vous permettre de trouver rapidement une photo.

1. Pressez le bouton [] pour passer en Mode Visualisation.

2. Utilisez les boutons [] / [] pour sélectionner les photos désirées.

- Pour afficher la photo précédente, appuyez sur le bouton [] / [].
- Pour afficher la photo suivante, appuyez sur le bouton [] / [].



3.3.1 Ecran LCD en Mode Visualisation Informations (Photo)

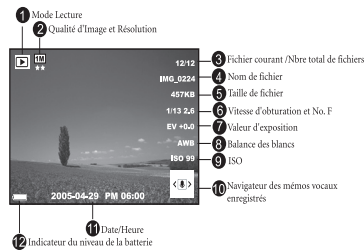

Français

3.3.2 Visualisation des photos

3.3.2.1 Agrandir des photos

Pendant que vous consultez vos photos, vous pouvez agrandir une portion sélectionnée d'une image. Cet agrandissement vous permet d'afficher les détails de l'image. L'Appareil Photo Numérique propose un agrandissement 4X pendant la visualisation.

- Réglez le niveau de zoom à l'aide du bouton zoom.
 - Pour zoomer vers l'avant, réglez la touche zoom vers la droite.
 - Pour zoomer vers l'arrière, réglez la touche zoom vers la gauche.
 - Le facteur d'agrandissement est affiché sur l'écran LCD.

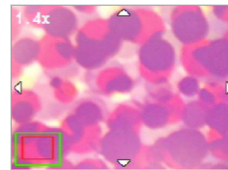

- Pour afficher une portion différente de la photo, pressez les boutons [ZOOM] / [ZOOM] / [ZOOM] / [ZOOM] pour régler la zone d'affichage.

Vous pourrez voir un cadre avec un carré à l'intérieur. Le cadre indique l'image entière, tandis que le carré indique l'emplacement de la zone actuellement agrandie.

- Pour revenir sur l'affichage standard, réglez la touche zoom vers la gauche jusqu'à ce que l'image standard (agrandissement 1X) apparaisse sur l'écran. Vous pouvez également presser sur le bouton [MENU] pour quitter directement.

- Si aucune photo n'est enregistrée dans la mémoire interne ou sur la carte mémoire, un message [No File(Pas de Fichier!)] apparaîtra sur l'écran LCD.
- Presser le bouton [MENU] pendant la lecture des photos modifie l'affichage LCD dans l'ordre suivant : Normal OSD → Infos Détaillées. → Arrêt Infos.

3.3.2.2 Affichage Miniatures(Visualisation par Index)

Cette fonction vous permet d'afficher simultanément neuf photos miniatures sur l'écran LCD, de cette façon vous pouvez facilement rechercher la photo dont vous avez besoin.

1. Réglez la touche zoom vers la gauche.
Neuf photos miniatures sont affichées simultanément.
2. Utilisez les boutons []/[]/[]/[]/[] pour choisir l'image que vous désirez afficher puis appuyez sur le bouton **OK** pour afficher la photo en mode plein écran.



3.3.2.3 Mémo Vocal

Ajouter un mémo vocal est une manière très utile pour ajouter des remarques et des mementos aux photos.

1. En Mode Visualisation, sélectionnez une photo. L'icône [] est affichée dans l'angle inférieur droit de l'écran LCD.
2. Pressez le bouton **OK** pour débiter l'enregistrement. Le temps écoulé est affiché sur l'écran LCD. Vous avez la possibilité d'ajouter un mémo vocal de 20s maximum pour chaque photo.
3. Pressez le bouton **OK** de nouveau pour arrêter l'enregistrement.
4. Pressez le bouton **OK** de nouveau pour lire le mémo vocal.
5. Si vous souhaitez supprimer le mémo vocal, pressez le bouton [], choisissez [Delete Voice](Supprimer Voix) puis pressez le bouton **OK**.

3.3.3 Suppression des Fichiers

Lorsque vos photos, vos clips vidéo ou vos mémos vocaux ne vous conviennent pas, vous pouvez choisir de les supprimer un par un ou tous à la fois. Veuillez remarquer que les fichiers supprimés ne peuvent pas être restaurés.























1. En mode Visualisation, pressez le bouton [] pour supprimer les fichiers.
 - Choisissez [Delete One](Supprimer Une) et pressez le bouton **OK** pour supprimer les fichiers que vous ne voulez pas conserver.
 - Choisissez [Delete All](Supprimer Toutes) et pressez le bouton **OK** pour supprimer tous les fichiers.
 - Choisissez [Delete Voice](Supprimer Voix) et pressez le bouton **OK** si vous souhaitez supprimer une photo qui contient un mémo vocal.
 - Choisissez [Exit](Quitter) pour annuler l'action.

☞ **Les fichiers protégés ne peuvent pas être effacés.**

3.3.4 Menu des Réglages du Mode Visualisation

3.3.4.1 Menu du Mode Visualisation

1. Pressez le bouton [] pour passer en Mode Visualisation.
2. Pressez le bouton [] pour accéder au menu ensuite utilisez les boutons []/[] pour choisir les paramètres du menu que vous souhaitez modifier.
3. Utilisez les boutons []/[] pour choisir l'item désiré puis pressez le bouton **OK** pour confirmer.
4. Appuyez sur le bouton [] pour quitter le menu.

Icône	Item	Option	Description des fonctions
	Protéger		<p>Positionne les fichiers dans l'état lecture-uniquement pour leur empêcher d'être effacés par erreur.</p> <p>Pour protéger vos fichiers, suivez les étapes ci-dessous.</p> <ol style="list-style-type: none"> 1. Pressez [] lorsque le menu [Protéger] est affiché. 2. Vous pouvez choisir de protéger ou de déprotéger les fichiers de la manière suivante. <ul style="list-style-type: none"> - Choisissez [Protect One](Protéger Une) et pressez le bouton OK pour protéger le fichier actuellement sélectionné. Si vous souhaitez annuler la protection du fichier actuel, choisissez [Unprotect One](Déprotéger Une) et pressez le bouton OK. - Choisissez [Protect All](Protéger Toutes) et pressez le bouton OK pour supprimer tous les fichiers. Si vous souhaitez annuler la protection de tous les fichiers, choisissez [Unprotect All](Déprotéger Toutes) et pressez le bouton OK. - Pour quitter le menu, pressez [Quitter]. <p> L'icône  sera affichée si le fichier est protégé.</p>
	Découper		<p>Permet de découper une portion de la photo prise.</p> <p>Pour découper une photo prise, suivez les étapes ci-dessous.</p> <ol style="list-style-type: none"> 1. En Mode Visualisation, choisissez Découper puis pressez []. 2. Utilisez la touche zoom et les boutons /[] / [] / [] pour vous placer sur la portion voulue. 3. Pressez le bouton OK. <p> Une photo découpée sera enregistrée sous un autre nom de fichier et aura une taille plus petite.</p>
	Diaporama	 1 sec.  3 sec.  5 sec.	<p>Cette fonction vous permet de régler l'intervalle pendant la lecture de vos photos en ordre séquentiel sous la forme d'un diaporama. Il s'agit d'une fonction très utile et pratique pour visualiser les photos enregistrées et pour les présentations.</p> <p>Une fois que vous avez sélectionné une option, le diaporama débutera automatiquement. Si vous souhaitez l'arrêter, pressez simplement le bouton OK.</p>
	Redimens.	 2048 x 1536  1600 x 1200  1280 x 960  640 x 480	<p>Permet de modifier la taille d'une photo prise.</p> <p>Pour redimensionner une photo prise, suivez les étapes ci-dessous.</p> <ol style="list-style-type: none"> 1. En Mode Visualisation, choisissez Redimensionner puis sélectionnez l'option désirée. 2. Pressez le bouton OK. <p> Une photo redimensionnée sera enregistrée sous un autre nom de fichier et aura une taille plus petite.</p>





3.3.5 Informations sur l'Écran LCD en Mode Visualisation (Clips Vidéo)

1. Mode Visualisation
2. Fichier courant/Nombre total des fichiers
3. Nom du fichier
4. Taille du fichier
5. Navigateur de Lecture
6. Date/Heure
7. Indicateur du niveau de la batterie



3.3.6 Lecture des clips vidéo

En Mode Visualisation, utilisez le navigateur de lecture  en bas à droite de l'écran LCD pour contrôler la lecture des clips vidéo.







- Appuyez sur le bouton **OK** pour débiter la lecture d'un clip vidéo.
 - Pour faire une pause ou reprendre la lecture d'un clip, appuyez de nouveau sur le bouton **OK**.
 - Pour arrêter la lecture, appuyez sur le bouton []
 - Pour lire le clip vidéo avec le ralenti, pressez les boutons [] .
 - Pour débiter la lecture vidéo en avance rapide, appuyez sur le bouton []
 - Pour débiter la lecture vidéo en retour rapide, appuyez sur le bouton []
-  • La fonction zoom ne peut pas être activée lors de la lecture des clips vidéo.

Français







3.4 Mode Configuration

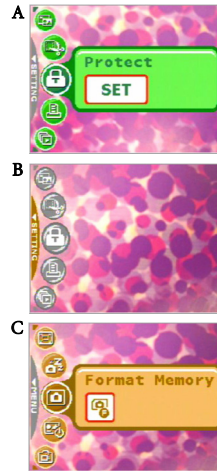













Quel que soit le mode en cours d'utilisation, le Mode Configuration est toujours accessible. Sélectionnez vos préférences pour l'appareil par le biais de ce mode.



























3.4.1 Menu Mode Configuration

1. Dans n'importe lequel des modes (Mode Prise de Vue, Mode Film ou Mode Visualisation), pressez le bouton [] (Étape **A**).
2. Pressez le bouton [] **deux fois** pour accéder au Mode Configuration (Étape **B** et étape **C**).
3. Utilisez les boutons []/[] pour sélectionner les paramètres du menu que vous souhaitez modifier.
4. Utilisez les boutons []/[] pour choisir l'item désiré puis pressez le bouton **OK** pour confirmer.
5. Pour quitter le menu, pressez deux fois le bouton [] .



Icône	Item	Option	Description des fonctions
	Mémoire	 Form. Mém.	<ul style="list-style-type: none"> - [Form. Mém.]: Cette option est affichée lorsqu'il n'y a plus de carte mémoire SD chargée. Elle efface toutes les données et reformate la mémoire interne. Les fichiers protégés sont également effacés.
	Mémoire	<ul style="list-style-type: none">  Copier sur SD  Formater SD 	<ul style="list-style-type: none"> - [Copier sur SD]: Cette option est affichée lorsqu'il y a une carte mémoire SD chargée. Vous pouvez copier les fichiers de la mémoire interne de l'appareil photo vers une carte mémoire SD chargée. - [Formater SD]: Cette option est affichée lorsqu'il y a une carte mémoire SD chargée. Elle efface toutes les données présentes sur la carte mémoire SD et reformate la carte. Les fichiers protégés sont également effacés. Une carte mémoire SD ne peut pas être formatée si elle est protégée en écriture. <p> Ce menu est disponible uniquement lorsqu'une carte mémoire SD est insérée.</p>

Icône	Item	Option	Description des fonctions
	Image Démar.	[SET]	<p>Pour définir une image de démarrage affichée à chaque fois que vous allumez l'appareil photo, suivez les étapes ci-dessous :</p> <ol style="list-style-type: none"> Sélectionnez [SET] puis il vous sera demandé de choisir une photo de démarrage. Utilisez les boutons [] / [] / [] / [] pour choisir la photo que vous préférez.  <ol style="list-style-type: none"> Si vous n'êtes pas satisfait avec la photo préinstallée, vous pouvez vous déplacer dans l'angle inférieur droit de l'écran LCD pour personnaliser votre photo de démarrage en choisissant les photos que vous aimez. Une fois la sélection effectuée, pressez le bouton OK pour confirmer, puis pressez [MENU] pour quitter.
	Eco. Ener	[OFF] [30s] [1min] [3min]	<p>Si vous n'appuyez sur aucun bouton pendant un certain temps alors que l'appareil photo est allumé, il passera en mode d'économie d'énergie en fonction de vos paramètres. Si l'appareil photo est en état d'économie d'énergie réactivez-le en pressant sur l'un des boutons.</p> <ul style="list-style-type: none"> – Arrêt/30 sec./1 min./3 min. <p> Si l'appareil photo n'est pas utilisé pendant 5 minutes, l'appareil photo s'arrêtera automatiquement.</p>
	Aperçu	[ON] [OFF]	<p>Permet d'obtenir rapidement un aperçu immédiatement après avoir pris une photo. Cet aperçu s'affiche brièvement puis vous pouvez poursuivre avec la prise des photos suivantes.</p> <ul style="list-style-type: none"> – Marche/Arrêt
	Zoom num.	[ON] [OFF]	<p>Permet d'activer ou de désactiver le Zoom num. en fonction de vos préférences.</p> <ul style="list-style-type: none"> – Marche/Arrêt
	Vol. lecture		<p>Permet de régler le volume des clips vidéo ou des mémos vocaux. Vous pouvez régler le volume avec les boutons [] / [].</p>
	Son Système	[ON] [OFF]	<p>Permet d'activer ou pas les effets sonores du système comme avec le bip lors des pressions ou des déplacements.</p>

Icône	Item	Option	Description des fonctions
	Allumer	 [ON]  [OFF]	Vous permet d'activer ou de désactiver la fonction d'allumage avec les boutons ENR et LECTURE. [On] : Vous permet d'activer la fonction d'allumage avec les boutons ENR et LECTURE. [Off] : Vous permet de désactiver la fonction d'allumage avec les boutons ENR et LECTURE.
	Lumin. LCD	 [Normal]  [Brillant]	Permet de régler la luminosité de l'écran LCD sur Normal ou Brillant.
	Date/Heure		Permet de régler la date et l'heure de l'appareil photo. 1. Utilisez les boutons []/[] pour sélectionner l'item que vous souhaitez modifier. 2. Pressez le bouton OK puis utilisez les boutons  /[] pour régler le paramètre.  Le réglage de la date et de l'heure est important car ces informations sont enregistrées en même temps que la photo prise et elles sont utilisées si vous avez activé la fonction [Horodateur]. Réglez la date et l'heure avant d'utiliser l'appareil photo pour la première fois.
	Format date	 [YMD]  [MDY]  [DMY]	Permet de sélectionner le format de date utilisé pour la fonction [Horodateur]. - [] Année - Mois - Jour - [] Mois - Jour - Année - [] Jour - Mois - Année
	Sortie Vidéo	 [NTSC]  [PAL]	Le port sortie TV de l'appareil photo offre une sortie vidéo permettant de visionner les photos et les clips vidéo sur une TV standard. Réglez le mode de sortie vidéo soit sur NTSC, soit sur PAL. Référez-vous aux autorités locales pour connaître le format utilisé dans votre Pays/Région, NTSC ou PAL.
	Langue		Permet de régler la langue affichée sur l'écran LCD.
	Réinitial.	 [Réin. no fic.]  [Réinitialiser]	- [Réin. no fic.] : L'appareil photo assigne automatique des numéros aux fichiers de photos, clips vidéo et mémos vocaux enregistrés. Vous pouvez choisir de réinitialiser la numérotation automatique à partir de 1. - [Réinitialiser] : Sélectionner cette fonction réinitialise l'appareil photo à toutes ses valeurs d'usine par défaut.
	VERSION		Affiche le numéro de version du microprogramme installé.



4 FONCTIONS DEPENDANTES DU PC

4.1 Logiciel Fournis

L'Appareil Photo Numérique est livré avec les logiciels suivants. Pour installer le logiciel, référez-vous aux informations fournies sur les CD respectifs.

Ulead Photo Express

Ulead® Photo Express™ 5.0 SE est un logiciel complet de gestion des photos numériques. Copiez facilement vos photos d'un appareil photo numérique ou d'un scanner. Editez et retouchez vos photos en utilisant des outils d'édition faciles à utiliser, des filtres photographiques amusants et des effets spéciaux. Créez des projets uniques et partagez-les par email ou avec les options d'impression multiples.

Ulead Photo Explorer

Ulead® Photo Explorer™ 8.0 SE Basic offre une interface simple mais puissante pour transférer, naviguer, modifier et redistribuer des fichiers numériques. C'est un outil complet parfait pour les propriétaires d'appareil photo numérique, de Webcam, de caméscope numérique, de scanner et pour n'importe qui désirant manipuler des fichiers numériques.

Ulead VideoStudio

Ulead® VideoStudio™ 8 SE VCD est un logiciel d'édition de vidéo pour toute la famille qui rend l'édition des films aussi amusante que la création. Les utilisateurs pourront créer un film en trois étapes simples en suivant l'assistant de création. Partagez vos projets sur un VCD, une cassette, le Web ou même des appareils portables.

Français

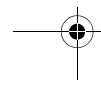
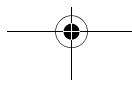
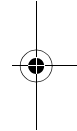
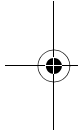

4.2 Mode USB

1. Connectez la petite extrémité du câble USB au Appareil Photo Numérique.
2. Connectez l'autre extrémité du câble USB sur un port USB de votre ordinateur.
3. Mise sous tension de l'appareil
Le message [USB] s'affiche sur l'écran.
4. Une icône "Disque amovible" apparaît dans le "Poste de travail". Cliquez sur cette icône pour accéder à vos photos ou vos clips vidéo.

 • Lorsque vous connectez l'appareil à un ordinateur, vous devrez obligatoirement utiliser une batterie.



Français

4.3 Mode Impression

Si une imprimante compatible avec le standard PictBridge est disponible, vous pouvez imprimer les photos en connectant directement l'appareil à l'imprimante sans avoir besoin d'utiliser un ordinateur.

Connexion de l'appareil à une imprimante compatible PictBridge

1. Connectez l'appareil photo à l'imprimante en utilisant le câble USB, qui est fourni, puis allumez l'appareil photo.
2. Choisissez [Imprimante].

-  • Si vous n'appuyez sur rien pendant 10 secondes, [Stockage amovible] (par exemple le disque dur externe) est automatiquement activé.
3. Une fois la connexion établie, il vous sera demandé de sélectionner [Print One] (Imprimer Une), [Print All] (Imprimer Toutes) ou [Print Index] (Index impression). Sélectionnez l'option désirée puis pressez le bouton **OK**.
 4. Les options [Setup] (Configuration), [Print] (Imprimer) et [Exit] (Quitter) seront affichées en bas de l'écran LCD.
 - Si vous choisissez [Setup] (Configuration), l'écran [Pictbridge Setup] (Réglage Pictbridge) sera affiché. Vous pouvez régler [Copies] (Nombre des copies), [Size] (Taille) et [Quality] (Qualité) si vous le désirez.
 - Si vous êtes satisfait avec les paramètres, sélectionnez [Print] (Imprimer) pour continuer.
 - Si vous voulez annuler, sélectionnez [Exit] (Quitter).

 • Les fonctions décrites ci-dessus peuvent différer en fonction des caractéristiques de l'imprimante à laquelle vous êtes connecté.



5 DÉPANNAGE

Veillez vous référer à la liste des problèmes et des solutions ci-dessous avant de renvoyer votre appareil photo pour obtenir un dépannage. Si le problème persiste, contactez votre revendeur local ou un centre de dépannage.

Problèmes	Causes	Solutions
Impossible d'allumer l'appareil photo.	Pas de batterie ou la batterie n'est pas correctement insérée.	Insérez la batterie correctement.
	La batterie est vide.	Rechargez la batterie
La batterie s'use rapidement.	La température externe est très basse.	—
	L'appareil est utilisé dans des endroits sombres, nécessitant le flash.	—
	La batterie n'est pas complètement rechargée. La batterie n'est pas utilisée pendant une longue période après avoir été rechargée.	Rechargez la batterie au maximum puis déchargez-la complètement au moins une fois avant l'utilisation.
La batterie ou l'appareil devient chaud.	L'appareil photo ou le flash a été utilisé continuellement pendant une période prolongée.	—
Le flash ne se déclenche pas. Le flash ne se recharge pas.	Le flash de l'appareil photo est arrêté.	Réglez le flash sur le mode Flash Auto.
	La source d'éclairage est suffisante.	—
Le flash est déclenché mais la photo est toujours foncée.	La distance entre le sujet et l'appareil est trop grande pour le rayon d'action du flash.	Rapprochez l'appareil du sujet et prenez la photo
La photo est trop brillante ou trop sombre.	L'exposition est excessive ou inappropriée.	Réinitialisez la compensation de l'exposition.
Impossible de formater la carte mémoire.	La carte mémoire est protégée en écriture.	Déverrouillez la carte mémoire.
	La carte mémoire a atteint sa durée de vie limite.	Insérez une nouvelle carte mémoire.

Problèmes	Causes	Solutions
Impossible de transférer des images.	L'espace libre sur le disque dur de votre ordinateur est insuffisant.	Assurez-vous que l'espace libre sur le disque dur est suffisant pour lancer Windows et que le pilote permettant de télécharger des fichiers image dispose d'un espace libre équivalent ou supérieur à la taille de la carte mémoire dans l'appareil photo.
	L'appareil photo n'est pas alimenté.	Rechargez la batterie.
L'appareil ne prend aucune photo lorsque j'appuis sur le déclencheur.	La batterie est faible.	Rechargez la batterie
	L'appareil n'est pas en mode de prise de vue.	Réglez l'appareil sur le Mode prise de vue.
	Le déclencheur n'est pas complètement enfoncé lorsqu'il est pressé.	Enfoncez le déclencheur au maximum.
	La mémoire intégrée ou la carte mémoire est pleine.	Utilisez une carte mémoire neuve ou supprimez des fichiers non voulus.
	Le flash est en train de se recharger.	Attendez jusqu'à ce que l'icône de flash s'arrête de clignoter sur l'écran.
L'appareil photo ne détecte pas la carte mémoire.	Formatez la carte mémoire avant la première utilisation ou avant de l'utiliser avec un autre appareil photo.	
Impossible d'imprimer des photos avec des imprimantes compatibles PictBridge.	L'appareil photo est connecté à l'imprimante lorsqu'il est éteint.	Veillez allumer l'appareil photo, sélectionner PictBridge puis le connecter à l'imprimante.

6 SPÉCIFICATIONS

Capteur d'image	Ecran CCD 1/2,5 pouces Pixels efficaces : 6,19 Mega pixels
Ecran LCD	Ecran LCD LTPS couleur 2,4 pouces (480 x 234 pixels)
Objectif	Distance focale: f = 5,8 - 17,4 mm (35 mm - 105 mm; Equivalent à un film de 35 mm) Nombre F : F2,8 / F4,8
Mise au point	Autofocus TTL Plage : Macro : 6 cm, Normal : 60 cm - l'infini
Déclencheur	Déclencheur mécanique : Jusqu'à 1/2000 sec.
Mode de Déclenchement	Auto/Manuel/Portrait/Paysage/Nocturne/Sport/Contre-jour/Portrait de nuit
Flash	Modes : Auto / Flash forcé / Réduction des yeux rouges / Flash arrêté / Sync.Lente Plage : 0,5 ~ 2,0m
Retardateur	10 sec, 2 sec,
Exposition	Compensation : ±2 EV (1/3 EV/étape)
ISO	Auto/100/200/400
Balance des blancs	Auto/Ensoleillé/ Nuageux/Couché du soleil /Tungstène/Fluorescent
Format de fichier	Image fixe : Format JPEG (EXIF2.2), DCF Taille d'image : 2816 x 2112, 2304 x 1728, 1600 x 1200, 1280 x 960, 640 x 480 pixels Clips vidéo : Format JPEG AVI avec enregistrement en continu. Taille d'image vidéo: 640 x 480, 320 x 240, 160 x 128 pixels (30 fps)
Stockage	Mémoire intégrée : Compatible avec carte mémoire SD 24MB
Affichage des images	Image unique / Lecture AVI / Miniatures / Diaporama
Interface	Sortie numérique : USB Sortie Audio/Vidéo (NTSC/PAL)
Source d'alimentation	Batterie Lithium-ion rechargeable
Dimensions (l x H x P)	92 x 60 x 24,5 mm
Poids	135+/-10g environ (sans batterie ni carte mémoire SD)
Prérequis du système (Pour Windows)	
* CPU Pentium 166 Mhz ou plus * 64 MB de RAM * Lecteur de CD-ROM	* Windows XP/ME/2000 * 128 MB d'espace disque dur libre * Port USB disponible



Cuidado de la cámara

- No utilice la cámara en los siguientes entornos: temperatura por debajo de 0°C o por encima de 40°C.
- No utilice ni guarde la cámara en los entornos enumerados a continuación:
 - Luz solar directa.
 - Lugares con mucha humedad o polvo
 - Junto a aparatos de aire acondicionado, radiadores eléctricos u otras fuentes de calor.
 - En un coche cerrado que se encuentra bajo la luz directa del sol
 - Superficies inestables
- Si la cámara se moja, frótela con un paño seco en cuanto sea posible.
- La sal o el agua del mar pueden provocar daños serios en la cámara.
- No utilice disolventes orgánicos, como el alcohol, etc, para limpiar la cámara.
- Si el objetivo o el visor óptico están sucios, utilice una brocha de objetivo o un trapo suave para limpiar el cristal. No toque el objetivo con los dedos.
- Para evitar descargas eléctricas, no intente desmontar ni reparar la cámara por sí mismo.
- El agua podría provocar un fuego o un cortocircuito, por lo tanto, almacene su cámara en un lugar seco.
- No utilice la cámara en exteriores cuando llueva o nieve.
- No utilice la cámara bajo o cerca del agua.
- Si entra en la cámara un sustancia extraña o agua, apáguela inmediatamente y desconecte las pilas. Elimine las sustancias extrañas o el agua y envíela a un servicio técnico.
- Transfiera los datos al equipo tan pronto como sea posible para evitar que se pierdan sus imágenes o videos.



Tabla de Contenidos

1. Introducción a la cámara.....	1
1.1 Comprobación del contenido de la caja.....	1
1.2 La cámara Componentes	1
1.2.1 Vista frontal	1
1.2.2 Vista posterior.....	2
1.2.3 LED de indicador.....	2
2. Preparación de la cámara para su utilización.....	3
2.1 Instalación de la batería	3
2.2 Carga de la batería	3
2.3 Inserción o extracción de una tarjeta de memoria SD	4
2.4 Ajuste de la fecha y hora.	4
3. Uso de la cámara.....	5
3.1 Modo Snapshot.....	5
3.1.1 Introducción a la captura de imágenes.....	5
3.1.2 Información del monitor LCD en el modo Snapshot...	6
3.1.3 Modificación de la configuración de la cámara.....	7
3.1.4 Ajuste del Modo Captura	7
3.1.5 Utilización del flash.....	8
3.1.6 Utilización del temporizador.....	9
3.1.7 Utilización del zoom óptico	9
3.1.8 Utilización del zoom digital	10
3.1.9 Cambio del enfoque	10
3.1.10 Ajuste del EV	10
3.1.11 Configuración del menú Modo Snapshot.....	10
3.1.11.1 Menú del modo Snapshot	10
3.1.11.2 Uso del disparo de intervalo	12
3.2 Modo Película	13
3.2.1 Información del monitor LCD en el modo Película...	13

Español

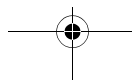
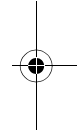
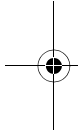

- 3.2.2 Configuración del menú del modo Película 14
 - 3.2.2.1 Menú modo película..... 14
- 3.2.3 Grabación con temporizador 15
- 3.3 Modo Reproducción 15
 - 3.3.1 Monitor LCD en el Modo de reproducción
 - Información (imagen) 16
 - 3.3.2 Visualización de imágenes 16
 - 3.3.2.1 Ampliación de imágenes..... 16
 - 3.3.2.2 Visualización de miniaturas (Reproducción de índice)..... 16
 - 3.3.2.3 Patrón de voz 17
 - 3.3.3 Borrado de archivos 17
 - 3.3.4 Configuración del menú Modo de reproducción..... 17
 - 3.3.4.1 Menú del Modo reproducción..... 17
 - 3.3.5 Información (Vídeo) de la pantalla LCD del modo Reproducción..... 19
 - 3.3.6 Reproducción de grabaciones de vídeo 19
- 3.4 Modo Configuración..... 19
 - 3.4.1 Modo Configuración..... 20
- 4. Funciones dependientes del PC 23**
 - 4.1 Software incluido 23
 - 4.2 Modo USB 24
 - 4.3 Modo Impresora 24
- 5. Solución de problemas 25**
- 6. Especificaciones 27**

Español

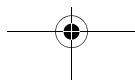
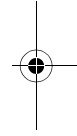
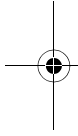

1 INTRODUCCIÓN A LA CÁMARA

1.1 Comprobación del contenido de la caja

Desembale con cuidado la caja del kit y asegúrese de que incluye los siguientes elementos.

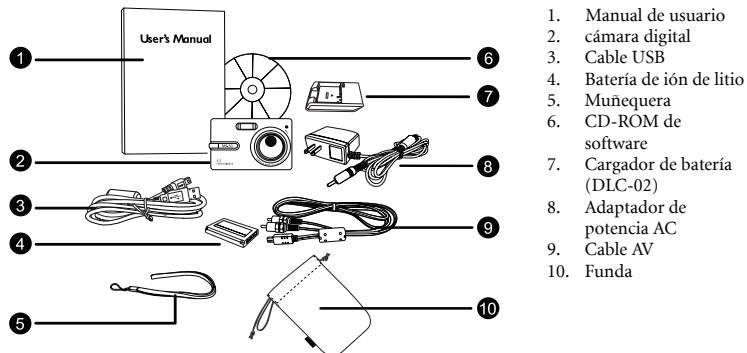

Si falta alguno de los artículos anteriores o parece estar dañado, póngase en contacto con su proveedor. Guarde el embalaje por si es necesario enviar la cámara para reparar.

1.2 La Cámara Componentes

1.2.1 Vista frontal

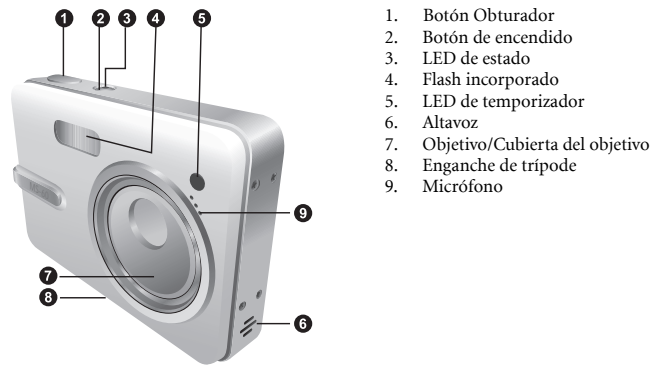

1.2.2 Vista posterior

1. Monitor LCD
2. Botón de reproducción automática
3. Botón de grabación automática
4. Enganche de la muñequera
5. Puerto USB/AV
6. Botones de navegador -- cuatro vías y **OK**
7. Botón Menú
8. Botón DISP

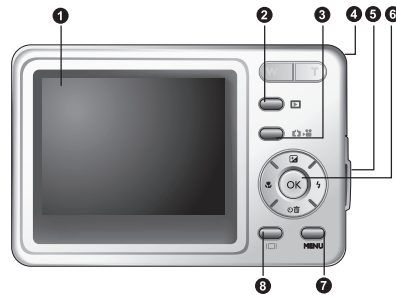

1.2.3 LED de indicador

Indicador	Estado	Descripción
LED de estado	Azul fijo	<ul style="list-style-type: none"> • La cámara está encendida y lista para usar. • La conexión USB está siendo utilizada. • La cámara está en el modo de ahorro de energía.
	Azul parpadeante	<ul style="list-style-type: none"> • La cámara está procesando o accediendo a datos.
	Naranja parpadeante	<ul style="list-style-type: none"> • Son mensajes de error o advertencia.
LED de temporizador	Rojo fijo	<ul style="list-style-type: none"> • Se activan las funciones de grabación de sonido o película.
	Rojo parpadeante	<ul style="list-style-type: none"> • Se activan las funciones de temporizador o fotografía de intervalo.

- La LCD de la cámara digital se ha fabricado mediante tecnología avanzada. A pesar de ello, la pantalla puede mostrar algunas ligeras manchas o colores poco comunes. Esto es normal y no es indicativo de un mal funcionamiento de la pantalla ni tampoco afectará la calidad de las fotografías que tome con la cámara.

2 PREPARACIÓN DE LA CÁMARA PARA SU UTILIZACIÓN

2.1 Instalación de la batería

Recomendamos que sólo use la batería de ión de litio recargable específica para su cámara. Asegúrese de que la cámara digital está apagada antes de insertar o extraer la batería.

Para introducir la batería

1. Abra la cubierta del compartimiento de pilas/tarjeta de memoria SD (A).
2. Inserte la pila con la orientación correcta que se muestra (B).
3. Empuje la batería hasta el fondo, hasta que la palanca de bloqueo de la batería se inserte en su sitio (C).
4. Cierre la cubierta de batería/tarjeta de memoria SD (D).

Para extraer la batería:

1. Abra la cubierta de la batería/tarjeta de memoria SD.
2. Suelte el seguro de la batería.
3. Cuando la batería haya salido un poco, tire lentamente hasta extraerla completamente.

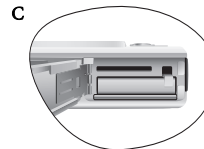
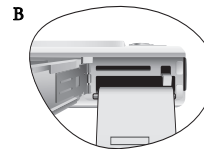

2.2 Carga de la batería

El estado de carga de la batería afecta el rendimiento de la cámara. Para maximizar el rendimiento de la batería y su duración, es recomendable que la cargue completamente utilizando el conjunto de carga especificado (cargador y adaptador de corriente de CA) y a continuación la descargue completamente con el uso normal por lo menos una vez.

1. Inserte la batería en el cargador, tal y como se indica en la ilustración.
2. Conecte un extremo del adaptador de alimentación CA al cargador.
3. Conecte el otro extremo del adaptador de alimentación CA a una toma de corriente.
4. Mientras la batería está cargándose, el indicador LED del cargador está encendido en rojo. Cuando la batería está totalmente cargada, se enciende en verde.

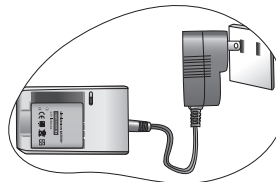

La duración del tiempo de carga depende de la temperatura ambiente y del estado de la batería.

- El la cámara debe utilizarse con el conjunto de carga especificado. Los daños causados por el uso de un adaptador incorrecto no están cubiertos por la garantía. Asegúrese siempre de que la cámara está apagada antes de extraer la batería.

- Es posible que la batería esté caliente después de cargarla o usarla. Esto es normal y no supone ninguna avería.
- Cuando utilice la cámara digital en entornos fríos, mantenga la cámara y su batería calientes colocándola dentro de su chaqueta o en otro entorno protector cálido.

2.3 Inserción o extracción de una tarjeta de memoria SD

La cámara está equipada con una memoria interna de 24MB, lo que le permite grabar vídeos, capturar imágenes o crear archivos de voz en la cámara. También puede ampliar la capacidad de memoria utilizando una tarjeta de memoria SD (Secure Digital) adicional para poder guardar más archivos.

1. Asegúrese siempre de que la cámara está apagada antes de insertar o extraer una tarjeta de memoria.
 2. Inserte una tarjeta de memoria SD con la orientación correcta como se muestra en la ilustración.
 3. Cierre la cubierta de la batería/tarjeta de memoria SD.
- Para retirar la tarjeta de memoria SD, asegúrese de que la cámara está apagada. Pulse ligeramente sobre el borde de la tarjeta de memoria y se expulsará.

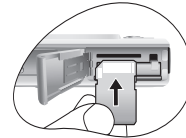

- **Asegúrese de formatear la tarjeta de memoria SD con esta cámara antes de empezar a usarla.**
- **Para evitar que se borren accidentalmente datos valiosos de la tarjeta de memoria SD, puede deslizar la ficha de protección contra escritura (en el lateral de la tarjeta de memoria SD) hasta la posición "LOCK" (Bloqueado).**

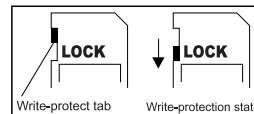

- Para guardar, editar o eliminar datos de una tarjeta de memoria SD, debe desbloquear la tarjeta.
- Mientras formatea la memoria interna, no inserte ninguna tarjeta de memoria en la cámara. En caso contrario, se formatea la tarjeta de memoria en lugar de la memoria interna de la cámara.
- El formato es una acción irreversible y los datos no se podrán recuperar posteriormente. Haga una copia de seguridad de sus datos antes de formatear.
- Es posible que las tarjetas con problemas de lectura o escritura no puedan ser formateadas correctamente.
- La cámara admite tarjetas de memoria SD de 8 MB, 16 MB, 32 MB, 64 MB, 128 MB, 256 MB, 512 MB y 1 GB. Es compatible con tarjetas de memoria SD fabricadas por Panasonic, Toshiba y Sandisk. Póngase en contacto con su distribuidor local si desea obtener más información de compra.

2.4 Ajuste de la fecha y hora.

Antes de usar la cámara por primera vez, ajuste la fecha y hora. Si desea obtener más información, consulte la tabla en el 3.4.1 "Modo Configuración" en la página 20.

4 Preparación de la cámara para su utilización



3 USO DE LA CÁMARA

3.1 Modo Snapshot

3.1.1 Introducción a la captura de imágenes

1. Pulse el botón [] para encender la cámara.
2. Componga la imagen en el monitor LCD en el modo Snapshot.
3. Pulse el botón del disparador a medio recorrido(1) y, a continuación, púselo por completo (2).

- Pulsar el botón del obturador a medio recorrido enfocará automáticamente la cámara y ajustará la exposición.
- El marco de área de enfoque cambiará a verde cuando la cámara se enfoque y se determine la exposición.
- Cuando el enfoque o la exposición no sean los adecuados, el marco del área de enfoque cambiará a rojo.

- Para revisar la última imagen capturada, pulse el botón []. Pulse el botón [] para volver al modo Snapshot.

- El monitor LCD se oscurecerá bajo la luz solar o luces brillantes. Esto no es una avería.
- Para evitar que las imágenes aparezcan borrosas mientras pulsa el botón del obturador, sostenga la cámara firmemente. Esto resulta especialmente importante cuando haga fotografías bajo condiciones de baja iluminación, donde la cámara puede reducir la velocidad del obturador para asegurar una correcta exposición de la imagen.
- Pulsar el botón [] cambia la pantalla LCD en la siguiente secuencia: OSD Normal → Información Detallada. → Información Desactivado.
- Si la opción Vista rápida está activada, la imagen capturada se mostrará mientras la imagen se escribe en la memoria.

① Pulse hasta la mitad del recorrido



































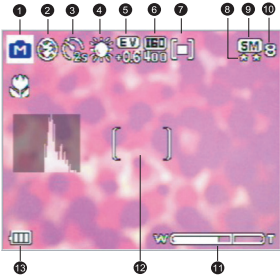





② Pulse hasta el fondo



Español

3.1.2 Información del monitor LCD en el modo Snapshot

- | | |
|--|--|
| <ol style="list-style-type: none"> 1. Modo disparo <ul style="list-style-type: none"> [] Auto [] Manual [] Retrato [] Paisaje [] Escena noche [] Deporte [] Contraluz [] Retrato en escena nocturna 2. Modo de flash <ul style="list-style-type: none"> [] Flash Auto [] Flash activado [] Flash desactivado [] Ojos rojos [] Sincronización lenta 3. Icono de temporizador (si se utiliza) <ul style="list-style-type: none"> [] Temporizador (2 seg) [] Temporizador (10 seg) [] Intervalo 4. Balance de blanco (si se elige pantalla [Información detallada]) <ul style="list-style-type: none"> [] Auto WB [] Soleado [] Nublado [] Tungsteno [] Fluorescente 5. EV (Valor de exposición)
-0.3, -0.6, -1.0, -1.3, -1.6, -2.0, +0.3, +0.6, +1.0, +1.3, +1.6, +2.0 6. ISO <ul style="list-style-type: none"> [] ISO Auto [] ISO 100 [] ISO 200 |  <ol style="list-style-type: none"> 7. Medida <ul style="list-style-type: none"> [] Media central [] Punto [] Media 8. Calidad de imagen <ul style="list-style-type: none"> [] Fina [] Normal 9. Resolución (Tam. imagen) <ul style="list-style-type: none"> [] 2816 x 2112 [] 2304 x 1728 [] 1600 x 1200 [] 1280 x 960 [] 640 x 480 10. Número de fotografías disponibles 11. Estado de zoom 12. Área AF 13. Indicador de nivel de carga de batería <ul style="list-style-type: none"> [] Carga completa [] Batería media [] Batería baja [] Batería casi agotada |
|--|--|

6 Uso de la cámara

3.1.3 Modificación de la configuración de la cámara

Se pueden cambiar los ajustes de la cámara mediante los siguientes botones de cuatro direcciones y el botón **OK**.

1. **Arriba / EV:**
 - Va hacia arriba en los menús.
 - Le permite ajustar los ajustes EV.
2. **Enfoque/ a la izquierda:**
 - Va hacia la izquierda en los menús.
 - Le permite elegir los ajustes de enfoque apropiados.
3. **Abajo/Temporizador/Captura por intervalos/Eliminar**
 - Va hacia abajo en los menús.
 - Recorre los ajustes del temporizador.
 - Alterna entre las funciones de toma de imágenes Captura.
 - Borra imágenes, vídeos o patrones de voz.
4. **Flash/derecho:**
 - Va hacia la derecha en los menús.
 - Le permite elegir los ajustes de flash apropiados.
5. **OK:** Confirma el valor seleccionado.

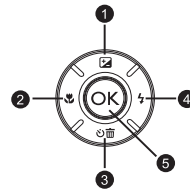

3.1.4 Ajuste del Modo Captura

Puede ajustar el modo de disparo para que ajuste imágenes siguiendo los pasos siguientes.

1. En el modo Snapshot, pulse el botón [**MENU**].
Se muestra el menú de modo de disparo.
2. Utilice los botones [**↶**]/[**↷**] para seleccionar el modo que desee y, a continuación, pulse el botón **OK** para confirmarlo.



La tabla siguiente le ayudará a elegir el modo de disparo apropiado:

Icono	Modo Captura	Descripción
[A]	Auto	Seleccione este modo cuando desee dejar que la configuración a la cámara para facilitar la captura de imagen.
[M]	Manual	Seleccione este modo cuando desee ajustar los ajustes de Balance Blanco, medición e ISO. Estos menús sólo están disponibles en el modo manual.
[S]	Retrato	Seleccione este modo cuando desee hacer una fotografía que resalte a la persona contra un fondo desenfocado (borroso). El flash se configurará como [☑] efectivo contra la reducción del fenómeno de ojos rojos.
[L]	Paisaje	Seleccione este modo para mejorar la saturación de color propia de las montañas, bosques y otros escenarios de paisajes o para hacer retratos que incluyan un elemento del fondo. El flash se fijará a [☑].

Icono	Modo Captura	Descripción
	Escena noche	Seleccione este modo cuando desee hacer una fotografía de gente en durante la noche o en una situación de escena noche. El flash se fijará a
	Deporte	Seleccione este modo cuando desee capturar sujetos a gran velocidad. El flash se fijará a
	Contraluz	Seleccione este modo cuando haya fotografías con la luz proveniente de detrás del sujeto. El flash se fijará a
	Retrato en escena nocturna	Seleccione este modo cuando desee realizar una captura clara del sujeto y el fondo. En este modo el flash está siempre activado.

- La descripción de cada modo de disparo sirve como referencia general para su propio beneficio. Configure la cámara digital para adecuarla a sus preferencias.
- El modo de disparo sólo puede ajustarse en el modo Snapshot.

3.1.5 Utilización del flash

El flash está diseñado para funcionar automáticamente cuando las condiciones de luz recomiendan el uso del flash. Puede capturar imágenes utilizando un modo de flash adecuado a las circunstancias. Si cambia el modo flash, la cámara conservará dicho ajuste aunque la apague.

1. En el modo Snapshot, se activa el flash automático
2. Recorra los botones para seleccionar otros modos de flash si lo desea.
3. Componga la imagen y pulse el botón de obturador.

La tabla siguiente le ayudará a elegir el modo de flash apropiado:



Icono	Flash	Descripción
	Flash Auto	El flash saltará automáticamente dependiendo de las condiciones de fotografía.
	Flash activado	El flash siempre se disparará sin tener en cuenta el brillo de alrededor. Seleccione este modo para capturar imágenes con alto contraste (contraluz) y sombras profundas.
	Flash desactivado	El flash no se activa nunca. Seleccione este modo en un lugar en donde las fotografías con flash estén prohibidas o cuando la distancia con respecto al objeto sea superior al rango efectivo del flash.
	Ojos rojos	Este modo reduce el fenómeno de los ojos rojos cuando desee capturar imágenes de aspecto natural de gente y animales en situaciones de iluminación baja. Al capturar las imágenes, el fenómeno de ojos rojos se puede reducir pidiendo al sujeto (persona) que mire a la cámara digital o que se acerque todo lo posible a la cámara.
	Sincronización lenta	Este modo abre el obturador durante un periodo de tiempo superior al habitual y dispara el flash antes de que se cierre. Seleccione este modo para iluminar un objeto de frente que le permita obtener a la vez un fondo más oscuro. Es apropiado para captura de imágenes nocturnas con personas en primer plano.

- El flash no se puede utilizar en el modo Película.
- Si selecciona sincronización lenta para evitar imágenes borrosas, se recomienda el uso de trípodes o elementos de fotografía estáticos.

3.1.6 Utilización del temporizador

El temporizador puede utilizarse en el modo Snapshot. Esta función es útil si desea salir en la fotografía.

1. Fije la cámara a un trípode o colóquela sobre una superficie estable.
2. En el modo Snapshot, cambie el botón [] para seleccionar el modo de temporizador que desee.

Icono	Temporizador	Descripción
[]	Temporizador (2 seg)	La cámara dispara automáticamente con un retraso de dos segundos.
[]	Temporizador (10 seg)	La cámara dispara automáticamente con un retraso de diez segundos.
[]	Intervalo	La cámara dispara automáticamente según un período de tiempo predeterminado hasta que se llena la tarjeta o se agota la batería.

3. Componga la imagen y pulse el botón de obturador.

- La función del temporizador se activará y el estado de la cuenta atrás se mostrará en el monitor LCD.
- El LED del temporizador parpadeará y la imagen se capturará transcurrido el tiempo predefinido.
- Para cancelar el temporizador en cualquier momento, pulse el [] botón.



- ☞ • La configuración del temporizador se cancelará automáticamente tras capturar la imagen.

3.1.7 Utilización del zoom óptico

La fotografía con zoom le permite capturar imágenes ampliadas hasta 3 veces el tamaño o fotografía angular dependiendo de la distancia al sujeto. Puede ampliar más aún el centro de la pantalla y hacer fotografías utilizando el zoom digital.

1. Pulse el botón [] para entrar en el modo Snapshot o en el modo Película.
2. Componga la imagen con los botones de zoom.
 - Al ajustar el botón hacia la derecha se amplía la imagen del sujeto y amplía el sujeto en la pantalla LCD.
 - Si ajusta la tecla hacia la izquierda verá una imagen con un ángulo abierto.
 - La posición de la lente se mueve según el ajuste del zoom solamente en periodo de zoom óptico.
3. Pulse el botón del obturador a medio recorrido para configurar el enfoque y la exposición y, a continuación, púselo completamente para capturar la imagen.





- ☞ • La función de zoom no se puede utilizar cuando se grabe vídeo. Ajuste el zoom antes de iniciar la grabación.

3.1.8 Utilización del zoom digital

Utilizando una combinación del zoom óptico de 3 aumentos y el zoom digital de 4 aumentos, se puede obtener una fotografía de hasta 12 aumentos para ajustar el sujeto y la distancia. El zoom digital es una función útil, sin embargo, cuando más se amplía una imagen, más pixelada (mayor grano) aparecerá.

3.1.9 Cambio del enfoque



1. En el modo Snapshot, recorra los [] botones para elegir entre los modos siguientes.

Icono	Enfoque	Descripción
	Normal (AF)	Enfoque automático normal (50 cm hasta el infinito).
[]	Macro	Enfoque automático gigante (6 cm). El flash se fijará a []
[]	Enfoque panorámico (PF)	Esta opción es capaz de reducir el tiempo de enfoque y mejorar la eficiencia de la captura de imágenes. Le ayuda a capturar objetos en movimiento rápido o en la oscuridad de forma fácil. La profundidad de campo en Modo [PF]: -La profundidad de campo en el Rango Amplio de la Lente de Zoom: 1m ~ 5m -La profundidad de campo en el Rango Medio de la Lente de Zoom: 1m ~ 4m -La profundidad de campo en el Rango Tele. de la Lente de Zoom: 1m ~ 3m

2. Composición de la imagen.
3. Pulse el botón del disparador a medio recorrido y, a continuación, púselo por completo.

3.1.10 Ajuste del EV

El EV (Valor de exposición) le permite iluminar u oscurecer una imagen. Utilice este ajuste cuando el brillo entre un objeto y el fondo no sea equilibrado, o cuando el objeto sólo ocupe una pequeña parte de la fotografía.

1. En el modo Snapshot, asegúrese de que el modo Snapshot esté ajustado a [Automático] o a [Manual]. Si desea obtener más información sobre los ajustes del Modo de disparo, consulte 3.1.4 "Ajuste del Modo Captura" en la página 7
2. Pulse el botón []. La barra de ajuste EV se mostrará en la parte inferior del monitor LCD.
3. Por defecto, el valor EV es 0. Puede ajustarse entre -2,0 y +2,0
 - Para aumentar el valor EV, pulse el botón [] y a continuación pulse el botón **OK**.
 - Para reducir el valor EV, pulse el botón [] y a continuación pulse el botón **OK**.

3.1.11 Configuración del menú Modo Snapshot





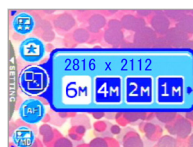









3.1.11.1 Menú del modo Snapshot

1. En el modo Snapshot, pulse el botón [MENU] para acceder al menú y a continuación use los botones [OK] / [F1] para seleccionar los ajustes de menú que desee cambiar.
2. Utilice los botones [F2] / [F3] para seleccionar el elemento del menú que desee y, a continuación, pulse el botón OK para confirmarlo.
3. Para salir del menú, pulse el botón [MENU].



Icono	Elemento	Opción	Descripción de la función
[Icono]	Tam. imagen	[6M] 2816 x 2112 [4M] 2304 x 1728 [2M] 1600 x 1200 [1M] 1280 x 960 [VGA] 640 x 480	Ajusta el tamaño de la imagen que se capturará. 💡 Las imágenes con mayor resolución necesitan más memoria. Si desea almacenar más imágenes en una cantidad de memoria limitada, utilice un tamaño de imagen menor.
[Icono]	Imagen Calidad	[★★] Fina [★] Normal	Configura la calidad (nivel de compresión) a la que se capturará la imagen.
[Icono]	Area AF	[Punto] [Multi]	Establece la forma de selección del área de enfoque.
[Icono]	Intervalo		Captura imágenes según los ajustes especificados. Para más detalles, consulte 3.1.11.2 "Uso del disparo de intervalo" en la página 12
[Icono]	Fecha	[ON] [OFF]	Imprime la fecha actual en la esquina inferior derecha de las imágenes capturadas. Esta función debe activarse antes de hacer la fotografía. Si desea obtener más información relativa a la fecha y la hora o sobre el formato de la fecha, consulte la tabla en 3.4 "Modo Configuración" en la página 19
[Icono]	Blanco Balance (Sólo disponible en el modo Manual)	[Auto WB] Auto WB [Soleado] Soleado [Nublado] Nublado [Tungsteno] Tungsteno [Fluorescente] Fluorescente	Configura el balance de blancos al capturar la imagen bajo condiciones de iluminación específicas. <ul style="list-style-type: none"> - Auto WB: Ajusta el balance de blanco de forma automática. - Soleado: Apropriado para situaciones con luz diurna brillante - Nublado: Apropriado para situaciones con tiempo oscuro, nublado o durante el crepúsculo. - Tungsteno: Apropriado para situaciones en las que se da una iluminación con tungsteno (incandescente). - Fluorescente: Apropriado para situaciones en las que se da una iluminación fluorescente.

Español

Icono	Elemento	Opción	Descripción de la función
	Medida (Sólo disponible en el modo Manual)	 Media central  Punto  Media	Ajusta la región del objeto o el encuadre en el que la cámara mide la luz. <ul style="list-style-type: none"> – Media central: La medición de la cámara se ajusta para el brillo medio del objeto en la región central del encuadre. – Punto: La medición de la cámara se ajusta para el brillo del objeto en el centro del encuadre. – Media: La medición de la cámara se ajusta para el brillo medio de todos los objetos en el encuadre.
	Efecto	 Normal  B/N  Sepia  Brillos	Aplica un tono o color a sus fotografías para crear un efecto artístico. <ul style="list-style-type: none"> – Normal: Ajustes de color RGB estándar aplicables para la fotografía general. – B/N: Fotografías en blanco y negro con sombras grises. – Sepia: Proporciona un estilo cálido y anticuado de imágenes en el que los colores son más tirando a marrones y naranjas. – Brillos: Proporciona colores más resultones y vibrantes.
	ISO (Sólo disponible en el modo Manual)	 ISO Auto  ISO 100  ISO 200  ISO 400	Configura la sensibilidad de la cámara a la luz. <ul style="list-style-type: none"> – ISO Auto: Ajusta automáticamente el valor ISO. – ISO 100: Equivale a una película en color ISO 100. Se usa para fotografía en exteriores con luz solar fuerte. – ISO 200: Equivale a una película en color ISO 200. Se usa para fotografía en exteriores o para interiores muy iluminados. – ISO 400: Equivale a una película en color ISO 400. Se usa para objetos en movimiento rápido.



- **Configuración del balance de blancos**
 El ojo humano se adapta a los cambios de la luz para que los objetos blancos sigan pareciendo blancos incluso cuando la luz cambia. Con una cámara digital, sin embargo, el color del sujeto está influido por el color de la luz que lo rodea. Este ajuste de color se denomina "Ajuste de balance de blancos". Esta configuración le permite configurar el balance de blancos al capturar imágenes bajo condiciones de iluminación específicas.

3.1.11.2 Uso del disparo de intervalo

La cámara proporciona una captura de imagen de intervalo según el ajuste. Este modo está disponible en la fotografía con temporizador. Puede especificar el intervalo y numerosas imágenes capturadas.



Para ajustar el disparo de intervalo:

1. En el modo Snapshot, seleccione menú de disparo de intervalo.
2. Utilice los botones / para ir de Interval (Intervalo) y Count (Contador), y pulse el botón **OK**.
 - Interval (Intervalo):
 - [15 seg.]: El intervalo de grabación es de 15 segundos.
 - [1 min.]: El intervalo de grabación es de 1 minuto.
 - [3 min.]: El intervalo de grabación es de 3 minutos.
 - [10 min.]: El intervalo de grabación es de 10 minutos.
 - [60 min.]: El intervalo de grabación es de 60 minutos.
 - Count (Contador): 2 ~ 99 cuentas (especificando cuántos disparos se pueden hacer).

- Utilice los botones []/[] para ajustar y a continuación pulse el botón **OK**.

Para capturar imágenes con la función Disparo de intervalo:

- En el modo Snapshot, recorra los [] botones para elegir entre los modos siguientes.
- Presione el botón de obturador para comenzar. Se capturarán imágenes según un Interval (Intervalo) predeterminado y el Count (Contador).
- Si desea detenerlo, pulse el botón del obturador.

3.2 Modo Película

Gracias a la función diseñada específicamente en su cámara, puede hacer una pausa en su grabación cuando más lo requieran las circunstancias. Utilícela siguiendo los pasos siguientes.

- Pulse el botón [] para entrar en el modo película. Se muestra la pantalla de grabación del video clip.
 - Encuadre el objeto en la pantalla LCD mediante el botón zoom si lo desea.
 - Se debe ajustar el zoom óptico antes de grabar.
 - El zoom óptico no se puede utilizar durante la grabación.
 - Presione el botón de obturador para comenzar a grabar.
 - Para detener la grabación, pulse el botón del obturador de nuevo.
 - Para detener la sesión de grabación, pulse el botón **OK**. Para continuar con la reproducción, pulse el botón **OK** de nuevo.
-  **El flash no se puede utilizar en el modo Película.**
 - La compensación EV no puede ajustarse o activarse en el modo Película.**
 - No abra la cubierta de la pila o de la tarjeta de memoria SD ni extraiga ninguna de las dos mientras graba un video en la tarjeta de memoria SD. Si lo hace podría dañar la tarjeta de memoria SD o destruir los datos.**
 - La duración de la grabación depende de la capacidad restante de la tarjeta de memoria o de la memoria incluida en la cámara. El tiempo restante se muestra en la esquina superior derecha del monitor LCD.**

3.2.1 Información del monitor LCD en el modo Película

- Modo Película
- Tiempo de grabación disponible
- Calidad de la película
- Estado de zoom
- Indicador de nivel de carga de batería

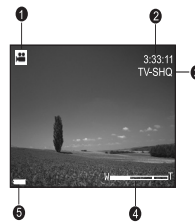

Español

3.2.2 Configuración del menú del modo Película



3.2.2.1 Menú modo película

1. En el modo Película, pulse el botón [MENU] para acceder al menú y a continuación use los botones [←] / [→] para seleccionar los ajustes de menú que desee cambiar.
2. Utilice los botones [↑] / [↓] para seleccionar el elemento del menú que desee y, a continuación, pulse el botón **OK** para confirmarlo.
3. Para salir del menú, pulse el botón [MENU]





Icono	Elemento	Opción	Descripción de la función
	Cal. película	TV-SHQ TV-HQ TV-S Web-HQ Web-S	Ajusta la calidad y el tamaño del video que desea grabar. <ul style="list-style-type: none"> - TV-SHQ: 640 x 480 - TV-HQ: 640 x 480 - TV-S: 320 x 240 - Web-HQ: 320 x 240 - Web-S: 160 x 128 <p>"SHQ" se refiere a "calidad súper alta". "HQ" se refiere a "alta calidad". "S" se refiere a "estándar".</p>
	Bal. blanco	Auto WB Soleado Nublado Tungsteno Fluorescente	Configura el balance de blancos al capturar el objeto bajo condiciones de iluminación específicas. <ul style="list-style-type: none"> - Auto WB: Ajusta el balance de blanco de forma automática. - Soleado: Apropriado para situaciones con luz diurna brillante - Nublado: Apropriado para situaciones con tiempo oscuro, nublado o durante el crepúsculo. - Tungsteno: Apropriado para situaciones en las que se da una iluminación con tungsteno (incandescente). - Fluorescente: Apropriado para situaciones en las que se da una iluminación fluorescente.
	Efecto	<input checked="" type="checkbox"/> Normal B & W Sepia Brillos	Ajusta el color del video clip que se va a grabar. <ul style="list-style-type: none"> - Normal: Ajustes de color RGB estándar aplicables para cualquier grabación en general. - B/N: Video clips en blanco y negro con sombras grises. - Sepia: Proporciona un estilo cálido y anticuado de video clips en el que los colores son más tirando a marrones y naranjas. - Brillos: Proporciona colores más resultones y vibrantes.



Español



	REC temp.	 Ajustar	Le permite ajustar sesiones de grabación por adelantado. Si desea obtener más información sobre los ajustes del Modo temporizador, consulte 3.2.3 "Grabación con temporizador" en la página 15
---	-----------	---	--

3.2.3 Grabación con temporizador

Gracias a la función especial Grabación con temporizador, podrá programar sesiones de grabación por adelantado siguiendo los pasos a continuación.

1. En el modo película, pulse el botón  para acceder al menú y a continuación vaya a [REC temp.].
2. Pulse .



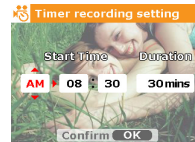

Se mostrará el ajuste de [Timer recording setting] (grabación con temporizador).
3. Pulse el botón  /  para ajustar cada elemento.

Pulse  /  para ir al elemento siguiente.
4. Después de ajustar la "Start Time" (Hora de inicio) y la "Duration" (Duración), pulse el botón **OK** para confirmar.
5. Se mostrará la pantalla de [Timer Recording Standby] (Grabación con Temporizador en Standby) de grabación con temporizador. Puede pulsar la tecla del zoom para ajustar la distancia.
 - Para activar esta función, pulse el obturador.
 - Para salir, pulse el botón .
6. Se mostrará la pantalla de [REC temp.]. La cámara entrará en el modo Standby y mostrará la información de la sesión. Si desea cancelar dicha acción, pulse el obturador.
7. Cuando se inicie la sesión de grabación, la cámara entrará en el modo de grabación. Una vez que la sesión de grabación se haya completado, la cámara se apagará automáticamente.



3.3 Modo Reproducción

En el modo Reproducción, puede ver, ampliar, cambiar el tamaño, clasificar y eliminar imágenes, reproducir video, grabar archivos de voz o ejecutar una presentación de diapositivas. Este modo también proporciona una presentación de imágenes en miniatura, que le permite buscar rápidamente la imagen que desee.

1. Pulse el botón  para entrar en el modo de reproducción.
2. Utilice los botones  /  para seleccionar las imágenes que desee.
 - Para ver la imagen anterior, pulse el botón .
 - Para ver la imagen siguiente, pulse el botón .



3.3.1 Monitor LCD en el Modo de reproducción Información (imagen)

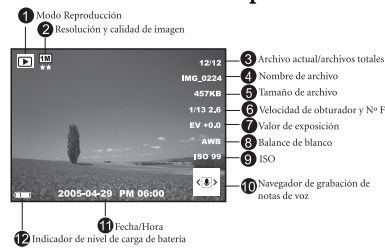

3.3.2 Visualización de imágenes

3.3.2.1 Ampliación de imágenes

Cuando visualice las imágenes, puede ampliar una porción seleccionada de la imagen. Esta ampliación le permite ver los detalles más pequeños de la imagen. La cámara le proporciona ampliaciones a 4X durante la reproducción.

1. Ajuste la proporción de zoom utilizando el botón de zoom.
 - Para ampliar, ajuste la tecla zoom hacia la derecha.
 - Para disminuir, ajuste la tecla zoom hacia la izquierda.
 - El factor de ampliación se mostrará en la pantalla LCD.
2. Para seleccionar una parte diferente de la imagen, pulse los botones [ZOOM] / [OK] / [MENU] / [ZOOM] / [OK] para ajustar el área que se va a mostrar.

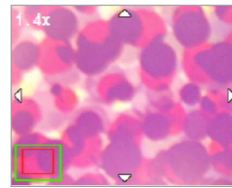





- Verá un marco con un cuadro en su interior. El marco indica la imagen completa, mientras que el cuadro muestra la ubicación del área ampliada en el momento.
3. Para volver a la imagen normal, ajuste la tecla zoom hacia la izquierda hasta que la imagen normal (Ampliación 1X) aparezca en la pantalla. También puede pulsar la tecla [ZOOM] para salir directamente.

- Si no hay ninguna imagen guardada en la memoria interna o la tarjeta de memoria, aparecerá en la pantalla LCD el mensaje [No File!] (Sin archivo).
- Pulsar el botón [ZOOM] durante la reproducción de imágenes, cambiará la pantalla LCD en la siguiente secuencia: OSD Normal → Información detallada. → Información desactivado.

3.3.2.2 Visualización de miniaturas (Reproducción de índice)



Esta función le permite ver nueve imágenes en miniatura simultáneamente en el monitor LCD para que pueda buscar la imagen que desee con facilidad.

1. Ajuste la tecla zoom hacia la izquierda.
Se muestran nueve imágenes en miniatura simultáneamente.
2. Utilice los botones []/[]/[]/[] para seleccionar la imagen a mostrar en tamaño normal y a continuación pulse el botón **OK** para mostrar la imagen seleccionada en modo pantalla completa.



3.3.2.3 Patrón de voz

La adición de un patrón de voz es una manera útil de añadir notas y recordatorios a imágenes.

1. Seleccione una imagen en el modo Reproducción. El icono [] se muestra en la esquina inferior derecha del monitor LCD.
2. Presione el botón **OK** para comenzar a grabar. El tiempo transcurrido se mostrará en la pantalla LCD. Podrá añadir un patrón de voz de hasta 20 segundos para cada imagen.
3. Pulse de nuevo el botón **OK** para detener la reproducción.
4. Pulse de nuevo el botón **OK** para reproducir el patrón de voz.
5. Si desea borrar un patrón de voz, pulse la tecla [], escoja [Delete Voice] (borrar voz), pulse la tecla **OK**.

3.3.3 Borrado de archivos







Si no está satisfecho con las imágenes, vídeos o patrones de voz, puede borrarlos una a una o todos de una vez. Tenga en cuenta que no podrá recuperar los archivos borrados.

1. En el modo Reproducción, pulse el botón [] para borrar archivos.
 - Escoja [Delete One] (Borrar Uno) y pulse el botón **OK** para borrar el archivo actual que no desee.
 - Escoja [Delete All] (Borrar todos) y pulse el botón **OK** para borrar todos los archivos que no desee.
 - Elija [Delete Voice] (borrar voz) y pulse el botón **OK** si desea borrar una imagen que contenga patrón de voz.
 - Elija [Exit] (Salir) para cancelar la acción.























 • Los archivos protegidos no se pueden eliminar

3.3.4 Configuración del menú Modo de reproducción

3.3.4.1 Menú del Modo reproducción

1. Pulse el botón [] para entrar en el modo de reproducción.
2. Pulse el botón [] para acceder al menú y a continuación use los botones []/[] para seleccionar los ajustes de menú que desee cambiar.
3. Utilice los botones []/[] para seleccionar el elemento del menú que desee y, a continuación, pulse el botón **OK** para confirmarlo.

4. Para salir del menú, pulse el botón [MENU]

Icono	Elemento	Opción	Descripción de la función
[]	Proteger	[]	<p>Configura los archivos como de sólo lectura para evitar que se borren por error.</p> <p>Siga los pasos siguientes para proteger sus archivos.</p> <ol style="list-style-type: none"> 1. Pulse [] cuando se muestre el menú [Protect]. 2. Puede elegir entre proteger o desproteger los archivos de la manera siguiente. <ul style="list-style-type: none"> - Escoja [Protect One] (Proteger Uno) y pulse el botón OK para proteger el archivo actual seleccionado. Si desea cancelar la protección de dicho archivo, elija [Unprotect One] (Desproteger uno) y pulse el botón OK. - Escoja [Protect All] (Proteger todos) y pulse el botón OK para proteger todos los archivos. Si desea cancelar la protección de todos los archivos, elija [Unprotect All] (Desproteger todos) y pulse el botón OK. - Para salir del menú, pulse [Exit] (Salir). <p> Se mostrará [] un icono si el archivo está protegido.</p>
[]	Recortar	[]	<p>Le permite elegir una porción de una imagen capturada.</p> <p>Para hacerlo, siga los pasos siguientes.</p> <ol style="list-style-type: none"> 1. En el modo reproducción, elija Trim y a continuación pulse []. 2. Utilice la tecla de zoom y los botones []/[]/[]/[] para mover la porción que desee. 3. Pulse el botón OK <p> Se guardará la imagen seleccionada como otro archivo con tamaño más pequeño.</p>
[]	Presentación	[] 1 sec. [] 3 sec. [] 5 sec.	<p>Esta función le permite establecer un intervalo temporal al reproducir las imágenes automáticamente en una secuencia como una presentación de diapositivas. Esta es una función muy útil y entretenida para ver imágenes capturadas y crear presentaciones.</p> <p>Una vez que seleccione una opción, la reproducción de diapositivas comenzará inmediatamente. Si desea detenerlo, pulse el botón OK.</p>
[]	Camb. Tamaño	[] 2048 x 1536 [] 1600 x 1200 [] 1280 x 960 [] 640 x 480	<p>Le permite cambiar el tamaño de una imagen capturada.</p> <p>Para hacerlo, siga los pasos siguientes.</p> <ol style="list-style-type: none"> 1. En el modo Reproducción, escoja Cambiar tamaño y a continuación seleccione la opción deseada. 2. Pulse el botón OK <p> Se guardará la imagen cuyo tamaño ha cambiado como otro archivo con tamaño más pequeño.</p>





3.3.5 Información (Vídeo) de la pantalla LCD del modo Reproducción

1. Modo Reproducción
2. Archivo actual/Total archivos
3. Nombre de archivo
4. Tamaño de archivo
5. Navegador de reproducción
6. Fecha/Hora
7. Indicador de nivel de carga de batería



3.3.6 Reproducción de grabaciones de vídeo

En el modo Reproducción, use el navegador de reproducción en  la esquina inferior derecha de la pantalla LCD para controlar la reproducción de vídeos.

- Pulse el botón **OK** para iniciar la reproducción de un archivo de vídeo.
- Para pausar o reanudar la reproducción de vídeo, pulse el botón **OK**
- Para detener la reproducción, pulse el botón [].
- Para reproducir el vídeo a cámara lenta, pulse el botón []
- Para detener la reproducción, pulse el botón []
- Para detener el rebobinado, pulse el botón []

 • La función de zoom no se puede activar mientras se reproducen los archivos de vídeo.

Español

3.4 Modo Configuración

En cualquiera de los modos que utilice, siempre puede acceder el modo configuración. Seleccione sus preferencias para la cámara con este modo.

3.4.1 Modo Configuración



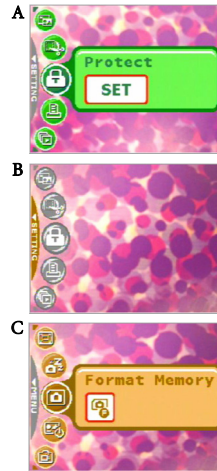























1. En cualquier modo (Snapshot, Película o reproducción), pulse el botón [MENU]. (Paso **A**).
2. Pulse el botón [OK] **dos veces** para entrar en el modo configuración (Paso **B** y Paso **C**).
3. Use los botones [←] / [→] para seleccionar los ajustes de menú que desee cambiar.
4. Utilice los botones [↑] / [↓] para seleccionar el elemento del menú que desee y, a continuación, pulse el botón **OK** para confirmarlo.
5. Para salir del menú, pulse el botón [OK] dos veces



Español

Icono	Elemento	Opción	Descripción de la función
[Icono]	Memoria	[Icono] F. mem. int.	<ul style="list-style-type: none"> - [F. mem. int.]: Esta opción se muestra cuando no hay cargada ninguna tarjeta de memoria SD. Borra todos los datos y reformatea la memoria interna. Los archivos protegidos también se eliminarán.
[Icono]	Memoria	[Icono] Archivo a SD [Icono] Formatear SD	<ul style="list-style-type: none"> - [Archivo a SD]: Esta opción se muestra cuando hay cargada una tarjeta de memoria SD. Puede copiar los archivos desde la memoria interna de la cámara a una tarjeta de memoria SD cargada. - [Formatear SD]: Esta opción se muestra cuando hay cargada una tarjeta de memoria SD. Borra todos los datos de la memoria SD y reformatea la tarjeta. Los archivos protegidos también se borran. Una tarjeta SD no podrá formatearse si está protegida contra escritura. <p>Este menú está solamente disponible cuando se ha insertado una tarjeta de memoria SD.</p>

Icono	Elemento	Opción	Descripción de la función
	Imag. inicial	[SET]	<p>Para configurar una imagen que se mostrará cada vez que encienda la cámara, siga los pasos siguientes.</p> <ol style="list-style-type: none"> 1. Seleccione [SET], y se le indicará que seleccione una imagen de inicio. Use los botones []/[]/[]/[]/[] para seleccionar la imagen que desee. <ol style="list-style-type: none"> 2. Si no está satisfecho con las imágenes preinstaladas, puede ir al esquina inferior derecha de la pantalla LCD para personalizar la imagen de inicio seleccionando las imágenes que quiera. 3. Una vez que haya realizado la selección, pulse el botón OK para confirmar y pulse [MENU] para salir.
	Ah. energía	[OFF] [30s] [1min] [3min]	<p>Si la cámara permanece sin utilizarse durante un cierto periodo de tiempo mientras está encendida, cambiará automáticamente al modo de ahorro de energía según sus ajustes. Si la cámara está en el modo de ahorro de energía, reactivela pulsando cualquier botón.</p> <ul style="list-style-type: none"> - Desactivado/30 seg./1 min./3 min. <p> Si no se usa la cámara durante 5 minutos, la cámara se apagará automáticamente.</p>
	Vista rápida	[ON] [OFF]	<p>Le permite obtener una imagen previa inmediatamente después de capturar dicha imagen. La vista previa se muestra brevemente y después podrá continuar tomando fotografías.</p> <ul style="list-style-type: none"> - ENCENDER/APAGAR
	Zoom digital	[ON] [OFF]	<p>Le permite activar o desactivar el Zoom digital según sus preferencias.</p> <ul style="list-style-type: none"> - ENCENDER/APAGAR
	Volumen repr.		<p>Le permite ajustar el volumen de los vídeos o patrones de voz. Puede ajustar el volumen mediante los botones []/[].</p>
	Sonido sist.	[ON] [OFF]	<p>Le permite activar o desactivar los efectos sonoros, como por ejemplo el pitido al pulsar o desplazarse.</p>

Icono	Elemento	Opción	Descripción de la función
	Encendido	 	Le permite activar o desactivar la función de encendido desde los botones Inst. GRAB e Inst. Repr. [On]: activa la función de encendido de la cámara desde los botones Inst. GRAB e Inst. Repr. [Off]: desactiva la función de encendido de la cámara desde los botones Inst. GRAB e Inst. Repr.
	Brillo LCD	 Normal  Brillante	Le permite ajustar el brillo del monitor LCD a normal o brillante
	Fecha/Hora		Le permite ajustar la fecha y hora de la cámara. 1. Use los botones  /  para seleccionar el elemento que desea cambiar. 2. Pulse el botón OK y use a continuación los botones  /  para ajustar. El ajuste de la fecha y hora es importante ya que se almacena dicha información con cada imagen que tome y se use si ha activado el sellado de fecha. Ajuste la fecha y hora antes de usar la cámara por primera vez.
	Formato hora	  	Le permite seleccionar el formato de la fecha usado para la función [Sellado de fecha]. –  Año - Mes - Fecha –  Mes - Fecha - Año –  Fecha - Mes - Año
	Salida Video	 	El puerto de salida de TV de la cámara le proporciona una salida de vídeo para ver imágenes o vídeos en pantallas de TV estándar. Configure la salida de vídeo a NTSC o PAL. Consulte con las autoridades locales si debe usar NTSC o PAL en su país o región.
	Idioma		Le permite configurar el idioma que se mostrará en el monitor LCD.
	Restablecer	 Rest. predet.  Num Reset	– [Rest. predet.]: Si selecciona esta función, recuperará todos los ajustes de fábrica determinados de la cámara. – [Num Reset]: La cámara asigna automáticamente números ascendentes a los nombres de archivo de todas las imágenes, vídeos y patrones de voz que grabe. Puede elegir reiniciar la numeración automática desde 1.
	Versión soft.		Muestra el número de versión de software instalado.

4 FUNCIONES DEPENDIENTES DEL PC

4.1 Software incluido

La cámara incluye el software siguiente. Para instalar el software, consulte la información suministrada con los CD.

Ulead Photo Express

Ulead® Photo Express™ 5.0 SE es un software de proyectos fotográficos para imágenes digitales. Adquiera fotografías sin esfuerzo desde cámaras digitales o escáneres. Edite y mejore las imágenes utilizando herramientas de edición fáciles de utilizar y divertidos filtros y efectos fotográficos. Cree proyectos fotográficos creativos y comparta los resultados a través del correo electrónico y con múltiples opciones de impresión.

Ulead Photo Explorer.

Ulead® Photo Explorer™ 8.0 SE Básico proporciona una forma eficiente de transferir, examinar, modificar y distribuir soporte digital. Es la herramienta integral para propietarios de cámaras digitales, WebCams, videocámaras DV, escáneres o para cualquiera que pretenda manejar eficientemente el soporte digital.

Ulead VideoStudio

Ulead® VideoStudio™ 8 SE VCD es el software de edición de video doméstico que convierte la tarea de edición de películas en algo tan divertido como hacerlas. Los usuarios pueden hacer una película siguiendo tres pasos fáciles, utilizando el nuevo modo Asistente para película. Comparta los proyectos terminados en VCD, cinta, la Web y en dispositivos móviles.

Español

4.2 Modo USB

1. Conecte el extremo pequeño del cable USB a la cámara.
2. Conecte el extremo pequeño del cable USB al adaptador.
3. Conecte el otro extremo del cable USB a un puerto USB disponible del equipo.
4. Encienda la cámara.
Se mostrará la pantalla USB.
5. Aparecerá un icono de Disco extraíble en Mi PC. Pulse este icono para acceder a sus imágenes o videos.

☞ **Al conectarla a un equipo, es necesario instalar una batería.**



4.3 Modo Impresora

Si tiene disponible una impresora que admita PictBridge, las imágenes se pueden imprimir conectando la cámara digital directamente a la impresora compatible con PictBridge sin utilizar un PC.

Conexión de la cámara a una impresora compatible con PictBridge.

1. Conecte la cámara a la impresora mediante el cable USB incluido y, a continuación, encienda la cámara.
2. Seleccione [Impresora].
 - Si no se realiza ninguna selección en 10 segundos, se activa en su lugar [Almacenamiento masivo] (p. ej., disco duro externo).
3. Una vez se haya establecido la conexión, se le pedirá que seleccione [Print One] (Imprimir uno), [Print All] (Imprimir todo), o [Print Index] (Imprimir índice). Seleccione la opción que desee y pulse el botón **OK**.
4. Se mostrarán las opciones [Setup] (Configuración), [Print] (Imprimir) y [Exit] (Salir) en la parte inferior de la pantalla LCD.
 - Si selecciona [Setup] (Configuración), se mostrará la pantalla [Pictbridge setup]. Podrá ajustar [Copies] (Copias), [Size] (Tamaño), and [Quality] (Calidad) si lo desea.
 - Si está contento con los ajustes, seleccione [Print] (Imprimir) para continuar.
 - Si desea cancelar, seleccione [Exit] (Salir).

☞ **Las funciones descritas anteriormente pueden variar dependiendo del diseño de la impresora a la que esté conectado.**



5 SOLUCIÓN DE PROBLEMAS

Consulte los síntomas y las soluciones de la siguiente lista antes de enviar la cámara a reparar. Si el problema continua, póngase en contacto con su distribuidor o centro de reparaciones.

Síntoma	Causa	Solución
No se puede encender la cámara.	No hay batería o no está instalada correctamente.	Instale la batería correctamente.
	La batería no tiene carga.	Recargue la batería.
	El adaptador de corriente CA no está conectado correctamente.	Conecte el adaptador de corriente CA correctamente.
Hay pérdida de capacidad de la batería.	La temperatura externa es extremadamente baja.	—
	Se han hecho muchas fotografías en lugares oscuros que han necesitado flash.	—
	La batería no está cargada completamente. La batería no se ha utilizado durante mucho tiempo tras recargarla.	Cargue la batería completamente y descárguela al menos una vez antes de usarla.
La batería de la cámara está caliente.	La cámara o el flash se han usado continuamente durante un período largo de tiempo.	—
El flash no se activa nunca. El flash no se recarga.	El flash de la cámara está apagado.	Ajuste el flash a flash automático.
	La fuente de luz es suficiente.	—
Incluso si se activa el flash, la imagen está oscura.	La distancia al sujeto es mayor que el rango efectivo del flash.	Acérquese al sujeto y haga la fotografía.
La imagen es demasiado brillante o demasiado oscura.	La exposición es excesiva o inadecuada.	Reajuste la compensación por exposición.
No puedo formatear la tarjeta de memoria.	La tarjeta de memoria está protegida contra escritura.	Desactive la protección contra escritura.
	La tarjeta de memoria no puede utilizarse más.	Introduzca una nueva tarjeta de memoria.



Síntoma	Causa	Solución
No puedo descargar las imágenes.	El espacio disponible en el disco duro del equipo no es suficiente.	Compruebe si el disco duro tiene suficiente espacio para ejecutar Windows y si la unidad para cargar los archivos de imagen dispone, al menos, de igual o más espacio que en la tarjeta de memoria de la cámara.
	No le llega energía a la cámara.	Recargue la batería.
La cámara no dispara cuando se pulsa el botón de hacer fotos.	Se está agotando la batería .	Recargue la batería.
	La cámara no se encuentra en el modo Captura.	Vaya al modo Hacer fotos.
	No se ha pulsado el botón del obturador todo el recorrido.	Pulse el botón del obturador hasta el fondo.
	La memoria interna o la tarjeta de memoria no tienen espacio libre.	Cargue una tarjeta nueva o elimine archivos que no desee guardar.
	El flash se está recargando.	Espere hasta que el icono del modo de flash, que se indica en la pantalla, deje de parpadear.
La cámara no reconoce la tarjeta de memoria.	Formatee la tarjeta de memoria antes de usarla por primera vez o antes de usarla con otra cámara.	
No puedo imprimir imágenes con impresoras compatibles con PictBridge.	La cámara está conectada a la impresora cuando la cámara está apagada.	Encienda la cámara, seleccione PictBridge y conéctela a la impresora.

6 ESPECIFICACIONES



Sensor de imagen	CCD 1/2,5 pulgadas
	Píxeles efectivos: 6,19 Megapíxeles
Pantalla LCD	LTIPS LCD en color de 2,4 pulgadas (480 x 234 píxeles)
Objetivo	Distancia focal: f = 5,8 – 17,4 mm (35 mm - 105 mm; 35 mm Equivalente)
	Nº F: F2,8/F4,8
Enfoque	Enfoque automático TTL
	Rango: Macro: 6 cm, Normal: 60 cm ~ infinito
Obturador	Obturador mecánico: Hasta 1/2000 seg.
Modo Captura	Auto/Manual/Retrato/Apaisado/Nocturno/Deportivo/Luz de fondo/Retrato en escena nocturna
Flash	Modos: Auto / Forzado / Reducción de ojos rojos / Desactivado/Sincronización lenta
	Rango: 0,5 ~ 2,0m
Temporizador	10 seg, 2 seg
Exposición	Compensación: ±2 EV (1/3 EV / paso)
ISO	Auto/100/200/400
Balance de blancos	Auto/ Soleado / Nublado / Puesta de sol / Tungsteno / Fluorescente
Formato de archivo	Fotografía: Formato JPEG (EXIF2.2), DCF
	Tamaño de imagen: 2816 x 2112, 2304 x 1728, 1600 x 1200, 1280 x 960, 640 x 480 píxeles
	Clips de película: Formato Motion-JPEG AVI con grabación continua. Tamaño de película: 640 x 480, 320 x 240, 160 x 128 píxeles (30 fps)
Almacenamiento	Memoria integrada: Compatible con tarjeta de memoria SD de 24 MB.
Reproducción de imagen	Imagen sencilla / reproducción AVI / Miniaturas / Presentación
Interfaz (con adaptador)	Salida digital: USB
	Salida Audio/Video (PAL / NTSC)
Fuente de alimentación	Batería de ión de litio recargable
Dimensiones (Anchura x altura x profundidad)	92 x 60 x 24,5 mm
Peso	Aproximadamente 135+/-10g (sin batería, tarjeta de memoria SD)

Requisitos del sistema (para Windows)

* Pentium 166 Mhz o CPU superior	* Windows XP/ME/2000
* 64 MB RAM	* 128 MB de espacio libre en el disco duro
* Unidad de CD ROM	* Puerto USB disponible



Cura della fotocamera

- Non utilizzare la fotocamera nelle seguenti condizioni ambientali: temperatura inferiore a 0 °C o superiore a 40 °C.
 - Non utilizzare o conservare la fotocamera nelle seguenti condizioni ambientali:
 - Luce diretta del sole
 - Luoghi elevati e polverosi
 - Vicino a climatizzatori, riscaldatori elettrici o altre fonti di calore
 - In un'automobile chiusa alla luce diretta del sole
 - Collocazioni instabili
 - Se la fotocamera si bagna, pulirla al più presto possibile con un panno asciutto.
 - Il sale o l'acqua marina possono causare danni seri alla fotocamera.
 - Non usare solventi organici, come alcool, ecc., per pulire la fotocamera.
 - Se l'obiettivo o il mirino si sporcano, usare una spazzola per obiettivi o un panno soffice per pulirli. Non toccare l'obiettivo con le dita.
 - Per evitare scosse elettriche, non cercare di smontare o riparare la fotocamera da soli.
 - L'acqua può causare incendi o scosse elettriche; conservare pertanto la fotocamera in un luogo asciutto.
 - Non utilizzare la telecamera all'aperto in caso di pioggia o neve.
 - Non utilizzare la fotocamera in acqua, o vicino all'acqua.
 - Se nella fotocamera penetrasse acqua o una sostanza sconosciuta, spegnerla immediatamente e scollegare le batterie. Eliminare la sostanza sconosciuta o l'acqua e inviare la fotocamera al centro assistenza.
 - Per evitare di perdere le immagini acquisite, trasferire i dati sul proprio computer non appena possibile.
- 
- 



Sommario

1. Panoramica della fotocamera	1
1.1 Controllo dei contenuti della confezione.....	1
1.2 Componenti della fotocamera.....	1
1.2.1 Veduta frontale.....	1
1.2.2 Veduta posteriore	2
1.2.3 Indicatori LED	2
2. Preparazione all'uso della fotocamera	3
2.1 Installazione della batteria	3
2.2 Caricamento della batteria.....	3
2.3 Inserimento e rimozione di una scheda memoria SD.....	4
2.4 Impostazione di data e ora.....	4
3. Uso della fotocamera	5
3.1 Modalità Istantanea.....	5
3.1.1 Iniziare ad acquisire immagini	5
3.1.2 Informazioni del monitor LCD in modalità Istantanea	6
3.1.3 Cambiare le impostazioni della fotocamera	7
3.1.4 Impostazione della modalità Scatto	7
3.1.5 Uso del flash	8
3.1.6 Uso dell'autoscatto.....	9
3.1.7 Uso dello zoom ottico.....	9
3.1.8 Uso dello zoom digitale.....	10
3.1.9 Cambiare l'impostazione del fuoco	10
3.1.10 Regolazione del valore d'esposizione EV	10
3.1.11 Menu Impostazioni della modalità Istantanea	10
3.1.11.1 Menu della modalità Istantanea	10
3.1.11.2 Uso della funzione Intervallo scatti.....	12
3.2 Modalità Film	13
3.2.1 Informazioni del monitor LCD in modalità Film.....	13



3.2.2	Menu Impostazioni della modalità Film.....	14
3.2.2.1	Menu della modalità Film	14
3.2.3	Timer registrazione	15
3.3	Modalità Riproduzione	15
3.3.1	Informazioni del monitor LCD in modalità Riproduzione (Immagine).....	16
3.3.2	Prendere visione delle immagini	16
3.3.2.1	Ingrandimento delle immagini	16
3.3.2.2	Visualizzazione miniature (Riproduzione indice).....	16
3.3.2.3	Promemoria vocale.....	17
3.3.3	Eliminazione dei file	17
3.3.4	Menu Impostazioni della modalità Riproduzione	17
3.3.4.1	Menu della modalità Riproduzione	17
3.3.5	Informazioni del monitor LCD in modalità Riproduzione (Video).....	19
3.3.6	Riproduzione di sequenze video	19
3.4	Modalità Impostazione.....	19
3.4.1	Menu modalità Impostazione	20
4.	Funzioni Che Dipendono Dal PC.....	23
4.1	Pacchetto software.....	23
4.2	Modalità USB.....	24
4.3	Modalità Stampante	24
5.	Risoluzione dei problemi	25
6.	Specifiche.....	27



Italiano



1 PANORAMICA DELLA FOTOCAMERA

1.1 Controllo dei contenuti della confezione

Disimballare con cura la confezione ed assicurarsi di possedere gli elementi sotto elencati.

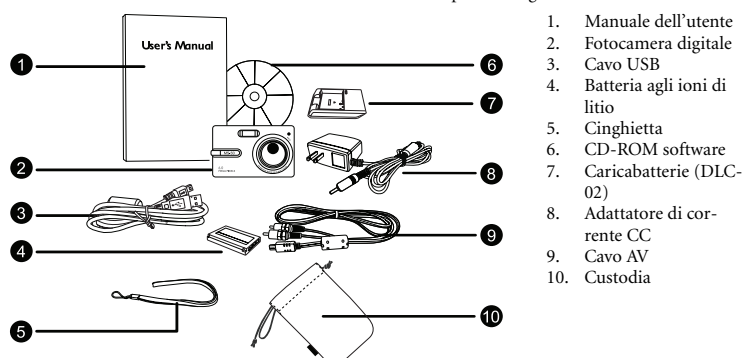

Se uno qualsiasi degli elementi manca o è danneggiato, mettersi in contatto con il rivenditore. Conservare i materiali d'imballaggio nel caso si deva inviare la fotocamera per riparazioni.

1.2 Componenti della fotocamera

1.2.1 Veduta frontale

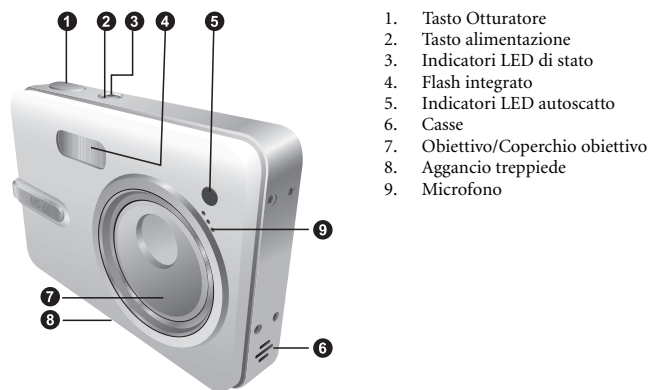

Italiano

1.2.2 Veduta posteriore

1. Monitor LCD
2. Tasto esecuzione istantanea
3. Tasto registrazione istantanea
4. Passante cinghietta
5. Porta AV / USB
6. Tasto Navigazione – quattro funzioni ed OK
7. Tasto Menu
8. Tasto Visualizzazione

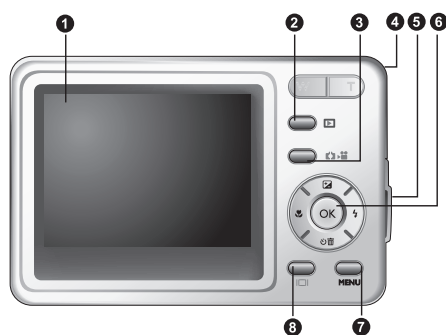

1.2.3 Indicatori LED

Indicatori	Stato	Descrizione
Indicatori LED di stato	Blu fisso	<ul style="list-style-type: none"> • La fotocamera è alimentata e pronta all'uso. • È in corso la connessione USB. • La fotocamera si trova in modalità risparmio energetico.
	Blu lampeggiante	<ul style="list-style-type: none"> • La fotocamera sta elaborando dati o vi sta accedendo.
	Arancione lampeggiante	<ul style="list-style-type: none"> • Ci sono messaggi d'errore o d'avviso.
Indicatori LED autoscatto	Rossa fisso	<ul style="list-style-type: none"> • È stata attivata la funzione di registrazione sonora o registrazione filmato.
	Rosso lampeggiante	<ul style="list-style-type: none"> • È stata attivata la funzione autoscatto o la funzione intervallo scatti.

- Il display LCD della fotocamera digitale è stato prodotto impiegando tecnologie sofisticate; tuttavia il display può avere dei punti illuminati oppure mostrare colori insoliti. Questo fenomeno è normale, non indica un guasto del display e non influenza la qualità delle fotografie acquisite con la fotocamera.

2 PREPARAZIONE ALL'USO DELLA FOTOCAMERA

2.1 Installazione della batteria

Si raccomanda vivamente di usare solamente la batteria ricaricabile agli ioni di litio specificata per la fotocamera. Assicurarsi che l'alimentazione della fotocamera sia disattiva prima di inserire o rimuovere la batteria.

Per inserire la batteria:

1. Aprire il coperchio scomparto batteria / alloggiamento scheda SD (A).
2. Inserire la batteria con l'orientamento corretto, come mostrato (B).
3. Spingere la batteria fino in fondo, fino a quando non si blocca in posizione (C).
4. Chiudere il coperchio scomparto batteria / alloggiamento scheda SD (D).

Per rimuovere la batteria:

1. Aprire il coperchio scomparto batteria / alloggiamento scheda SD.
2. Rilasciare la leva di blocco della batteria.
3. Come la batteria fuoriesce leggermente, con delicatezza estrarla completamente dallo scomparto.

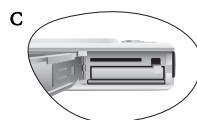
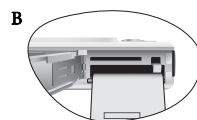

2.2 Caricamento della batteria

Lo stato di carica della batteria influenza le prestazioni della fotocamera. Per ottimizzare le prestazioni e la durata della batteria, si raccomanda di caricarla completamente utilizzando il caricabatterie specificato (caricabatterie e alimentatore CA), e quindi di scaricarla completamente durante l'uso, almeno una volta.

1. Posizionare la batteria nel caricabatterie, come mostrato nell'illustrazione.
2. Collegare uno dei capi del cavo dell'alimentatore CA al caricabatterie.
3. Collegare l'altra estremità dell'adattatore di corrente CC ad una presa a muro.

La durata dei tempi di carica dipende dalla temperatura d'ambiente e dallo stato della batteria.

4. Durante la ricarica della batteria, il LED del caricabatterie è di colore rosso. Una volta completata la ricarica, il led diventa di colore verde.

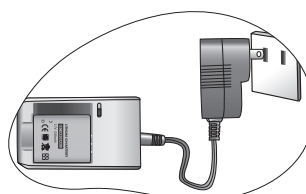

- Con la fotocamera si deve utilizzare il set caricabatterie consigliato. I danni provocati dall'uso di un adattatore di corrente inadeguato non sono coperti dalla garanzia. Assicurarsi sempre che la fotocamera sia spenta prima di rimuovere la batteria.



- La batteria può essere calda dopo essere stata caricata o usata. Questo è un fenomeno normale e non indica un guasto.
- Quando ci si trova in ambienti freddi, tenere calda la fotocamera e la sua batteria riponendola nella tasca interna della giacca oppure in altro luogo caldo e protetto.

2.3 Inserimento e rimozione di una scheda memoria SD

La fotocamera è dotata di una memoria interna da 24 MB, che consente registrare nella fotocamera sequenze video, immagini acquisite o di creare file vocali. Si può anche espandere la capacità della memoria usando una scheda memoria optional SD (Secure Digital) per archiviare più file.

1. Assicurarsi sempre che la fotocamera sia spenta prima di inserire o rimuovere una scheda memoria.
2. Inserire la scheda memoria SD nella direzione corretta, come mostrato nell'illustrazione.
3. Chiudere il coperchio dello scomparto batterie / alloggiamento scheda SD.

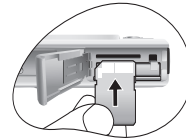

Assicurarsi che la fotocamera sia spenta prima di rimuovere la scheda memoria SD. Premere leggermente sul lato della scheda memoria che uscirà.



- Assicurarsi di formattare la scheda memoria SD usando la fotocamera prima di usarla.
- Per prevenire l'eliminazione accidentale di dati preziosi dalla scheda SD, si può far scorrere la linguetta di protezione scrittura (sul lato della scheda memoria SD) sulla posizione di "BLOCCO".

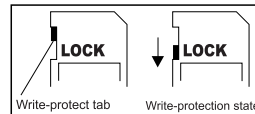

- Per salvare, modificare o cancellare i dati di una scheda memoria SD, è necessario sbloccare la scheda.
- Non inserire una scheda memoria nella fotocamera quando si vuole formattare la memoria interna. Diversamente, si formatterà la scheda memoria invece della memoria interna della fotocamera.
- La formattazione è un'azione irreversibile ed i dati non possono essere recuperati in un secondo tempo. Eseguire un backup dei dati prima della formattazione.
- Una scheda memoria SD che presenta qualsiasi tipo di problema di lettura o scrittura non può essere formattata in modo appropriato.
- Sono supportate le schede memoria SD delle seguenti dimensioni: 8 MB, 16 MB, 32 MB, 64 MB, 128 MB, 256 MB, 512 MB e 1 GB. La fotocamera è compatibile con schede memoria SD prodotte da Panasonic, Toshiba e Sandisk. Mettersi in contatto con il rivenditore locale per informazioni sull'acquisto.

2.4 Impostazione di data e ora

Impostare data e ora prima di utilizzare la macchina fotografica per la prima volta. Per altre informazioni, fare riferimento alla tabella della sezione 3.4.1 "Menu modalità Impostazione" a pagina 20.



2 USO DELLA FOTOCAMERA

3.1 Modalità Istantanea

3.1.1 Iniziare ad acquisire immagini



1. Premere il tasto [] per accendere la fotocamera.
 2. Comporre la fotografia nel monitor LCD in modalità Istantanea.
 3. Eseguire una mezza pressione del tasto otturatore (1) e poi premerlo completamente (2).
- La mezza pressione del tasto otturatore avvia la regolazione automatica di messa a fuoco ed esposizione.
 - La cornice dell'area di fuoco diventa di colore verde quando la fotocamera ha eseguito la messa a fuoco ed ha determinato l'esposizione.
 - Quando la messa fuoco o l'esposizione non è adatta, la cornice dell'area di fuoco diventa di colore rosso.

① Eseguire una mezza pressione

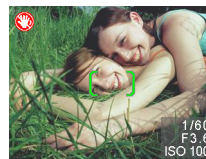

② Premere completamente



- Premere il tasto [] per vedere l'ultima immagine acquisita. Premere il tasto [] per tornare alla modalità Istantanea.
- Il monitor LCD si scurisce in condizioni di luce diretta del sole o di forte illuminazione. Questo fenomeno non indica un guasto.
- Tenere sempre saldamente la fotocamera quando si preme il tasto otturatore per prevenire l'acquisizione di foto sfuocate. Questo punto è importante in modo particolare quando si riprende in condizioni di scarsa illuminazione, nelle quali la fotocamera rallenta la velocità del diaframma per permettere alle immagini di avere la corretta esposizione alla luce.
- La pressione del tasto [] fa cambiare il display LCD nella seguente sequenza: OSD normale → Informazioni dettagliate → Informazioni disattivate.
- Se Vista rapida è impostata su "Attiva", l'immagine acquisita sarà visualizzata mentre è registrata nella memoria.

Italiano

3.1.2 Informazioni del monitor LCD in modalità Istantanea

- | | | |
|--|--|---|
| <ol style="list-style-type: none"> 1. Mod. scatto <ul style="list-style-type: none"> [Icona] Automatico [Icona] Manuale [Icona] Ritratto [Icona] Paesaggio [Icona] Scena nott. [Icona] Sport [Icona] Controluce [Icona] Ritratto notturno 2. Modalità Flash <ul style="list-style-type: none"> [Icona] Flash automatico [Icona] Flash attivo [Icona] Flash disattivo [Icona] Riduzione effetto occhi rossi [Icona] Sincronia rallentata 3. Icona autoscatto (se in uso) <ul style="list-style-type: none"> [Icona] Autoscatto (2 secondi) [Icona] Autoscatto (10 secondi) [Icona] Intervallo scatti 4. Bil. Bianco (se è scelta la visualizzazione [Informazioni dettagliate]) <ul style="list-style-type: none"> [Icona] Automatico WB [Icona] Soleggiato [Icona] Nuvoloso [Icona] Tungsteno [Icona] Fluorescente 5. EV (Valore d'esposizione) <ul style="list-style-type: none"> -0.3, -0.6, -1.0, -1.3, -1.6, -2.0, +0.3, +0.6, +1.0, +1.3, +1.6, +2.0 6. ISO <ul style="list-style-type: none"> [Icona] ISO automatico [Icona] ISO 100 [Icona] ISO 200 [Icona] ISO 400 | | <ol style="list-style-type: none"> 7. Misurazione <ul style="list-style-type: none"> [Icona] Media centr. [Icona] Punto [Icona] Media 8. Qualità imm. <ul style="list-style-type: none"> [Icona] Fine [Icona] Normale 9. Dimens. imm. (dimensioni immagine) <ul style="list-style-type: none"> [Icona] 6M 2816 x 2112 [Icona] 4M 2304 x 1728 [Icona] 2M 1600 x 1200 [Icona] 1M 1280 x 960 [Icona] VGA 640 x 480 10. Numero di scatti disponibili 11. Stato dello zoom 12. Area di fuoco automatico (AF) 13. Indicatore di carica della batteria <ul style="list-style-type: none"> [Icona] Batteria completamente carica [Icona] Batteria mezza carica [Icona] Batteria scarica [Icona] Batteria virtualmente esaurita |
|--|--|---|

Italiano

3.1.3 Cambiare le impostazioni della fotocamera

Le impostazioni della fotocamera possono essere cambiate usando il tasto a quattro funzioni ed **OK**.

1. **Su/EV:**
 - Fa scorrere verso l'alto nei menu.
 - Abilita a regolare le impostazioni EV.
2. **Sinistra/Fuoco:**
 - Fa scorrere verso sinistra nei menu.
 - Abilita a scegliere l'impostazione di fuoco appropriata.
3. **Giù/Autoscatto/Intervallo di scatto/Elimina**
 - Fa scorrere verso il basso nei menu.
 - Attiva/disattiva la funzione autoscatto.
 - Attiva le funzioni Intervallo di scatto.
 - Elimina immagini, sequenze video o promemoria vocali.
4. **Destra/Flash:**
 - Fa scorrere verso destra nei menu.
 - Abilita a scegliere l'impostazione appropriata del flash.
5. **OK:** Conferma l'impostazione scelta.

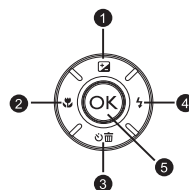

3.1.4 Impostazione della modalità Scatto

Impostare la modalità Scatto ed acquisire le immagini attenendosi alle fasi che seguono.

1. In modalità Istantanea, premere il tasto [**MENU**]. È visualizzato il menu della modalità Scatto.
2. Usare i tasti [**☺**]/[**☻**] per selezionare la modalità desiderata, e poi premere il tasto **OK** per confermare.

La tabella che segue aiuta a scegliere la modalità Scatto appropriata:

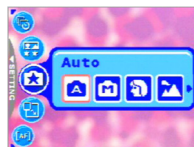

Icona	Mod. scatto	Descrizione
[A]	Automatico	Selezionare questa modalità quando si vuole che sia la fotocamera ad eseguire le impostazioni per fotografare con comodità.
[M]	Manuale	Selezionare questa modalità quando si vogliono regolare le impostazioni di Bilanciamento del bianco, Misurazione ed ISO. Questi menu sono disponibili solo in modalità Manuale.
[☺]	Ritratto	Selezionare questa modalità quando si vuole acquisire un'immagine che faccia risaltare la persona su uno sfondo sfuocato. Il flash è impostato su [☺], che è efficace per ridurre il fenomeno degli occhi rossi.
[☻]	Paesaggio	Selezionare questa modalità per migliorare la saturazione del colore di montagne, foreste o altri scenari oppure per acquisire ritratti caratterizzati da un paesaggio sullo sfondo. Il flash è impostato su [☻].

Italiano

Icona	Mod. scatto	Descrizione
	Scena nott.	Selezionare questa modalità quando si vogliono fotografare persone con una scena d'imbrunire o notturna sullo sfondo. Il flash è impostato su .
	Sport	Selezionare questa modalità quando si vogliono acquisire soggetti in rapido movimento. Il flash è impostato su .
	Controluce	Selezionare questa modalità quando si acquisiscono immagini dove la luce arriva dalle spalle del soggetto. Il flash è impostato su .
	Ritratto notturno	Selezionare questa modalità quando si vuole ottenere uno scatto chiaro del soggetto e dello sfondo. Con questa modalità il flash è sempre attivo.

- Le descrizioni di ciascuna modalità Scatto servono come guida generale e sono date per comodità. Impostare la fotocamera digitale in base alle proprie preferenze.
- La modalità Scatto può essere impostata solamente in modalità Istantanea.

3.1.5 Uso del flash

Il flash è progettato per attivarsi automaticamente quando le condizioni di luce richiedono l'uso del flash. Le immagini possono essere acquisite usando la modalità Flash che più si adatta alle proprie necessità. Se si cambia la modalità Flash, la fotocamera conserverà l'impostazione anche dopo essere stata spenta.

- In modalità Istantanea, il flash automatico è attivato per impostazione predefinita.
- Premere il tasto per selezionare altre modalità Flash, se desiderato.
- Comporre la fotografia e premere il tasto otturatore.

La tabella che segue aiuta a scegliere la modalità Flash appropriata.



Icona	Flash	Descrizione
	Flash automatico	Il flash si attiva automaticamente in base alle condizioni fotografiche.
	Flash attivo	Il flash si attiva sempre, indipendentemente dalle condizioni d'ambiente. Selezionare questa modalità per acquisire immagini con alto contrasto (controluce) ed ombre scure.
	Flash disattivo	Il flash non si attiverà. Scegliere questa modalità quando si fotografa in luoghi dove è proibito l'uso del flash, oppure quando la distanza dal soggetto è superiore alla portata effettiva del flash.
	Riduzione effetto occhi rossi	Questa modalità può ridurre il fenomeno occhi rossi quando si acquisiscono immagini naturali di persone ed animali in condizioni di scarsa illuminazione. Quando si acquisiscono le immagini, il fenomeno degli occhi rossi può essere ridotto chiedendo al soggetto (persona) di guardare direttamente nell'obiettivo oppure di avvicinarsi il più possibile alla fotocamera.
	Sincronia rallentata	Questa modalità apre il diaframma per un periodo più lungo del normale e fa scattare il flash immediatamente prima della sua chiusura. Selezionare questa modalità per illuminare il soggetto in primo piano permettendo anche la resa dello sfondo più scuro alle sue spalle. È appropriata per l'acquisizione di scene notturne con persone in primo piano.

- Il flash non può essere usato in modalità Film.
- Se si seleziona Sincronia rallentata, si raccomanda di usare un treppiede e di fotografare soggetti statici per evitare fotografie sfuocate.

3.1.6 Uso dell'autoscatto

L'autoscatto può essere impostato in modalità Istantanea. Questa funzione è utile per situazioni nelle quali si vuole apparire nella foto che si sta acquisendo.

1. Montare la fotocamera su di un treppiede, oppure collocarla su di una superficie stabile.
2. In modalità Istantanea premere il tasto [] per selezionare la modalità autoscatto desiderata.

Icona	Autoscatto	Descrizione
	Autoscatto (2 secondi)	La fotocamera scatta la fotografia automaticamente dopo due secondi di ritardo.
	Autoscatto (10 secondi)	La fotocamera scatta la fotografia automaticamente dopo due dieci di ritardo.
	Intervallo scatti	La fotocamera scatta automaticamente una fotografia ogni intervallo impostato fino all'esaurimento del supporto d'archiviazione o della batteria.

3. Comporre la fotografia e premere il tasto otturatore.

- La funzione autoscatto è attivata e sul monitor LCD è visualizzato il conto alla rovescia.
- Il indicatori LED autoscatto lampeggia e l'immagine è acquisita dopo che è scaduto l'intervallo impostato.
- Per annullare in qualsiasi momento l'autoscatto, premere il tasto [] .

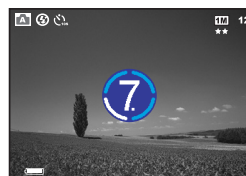

- **L'impostazione dell'autoscatto è annullata automaticamente dopo l'acquisizione dell'immagine.**

3.1.7 Uso dello zoom ottico

Lo zoom permette di acquisire immagini ingrandite di 3 volte oppure panoramiche in base alla distanza dal soggetto. Usando lo zoom digitale si può ulteriormente ingrandire il centro dello schermo ed acquisire le immagini.

1. Premere il tasto [] per accedere alla modalità Istantanea o Film.
2. Comporre la fotografia usando il tasto zoom.
 - Premendo il tasto verso destra si ingrandisce il soggetto e si allarga il soggetto sul monitor LCD.
 - Premendo il tasto verso sinistra si ottiene una veduta grandangolare.
 - La posizione dell'obiettivo cambia in base all'impostazione dello zoom solo con lo zoom ottico.
3. Eseguire una mezza pressione del tasto otturatore per impostare fuoco ed esposizione, poi premerlo completamente per acquisire l'immagine.







- **La funzione zoom non può essere usata durante la registrazione di sequenze video. Impostare lo zoom prima di avviare la registrazione.**

3.1.8 Uso dello zoom digitale

Grazie alla combinazione zoom con ingrandimenti ottico 3X ed ingrandimento digitale 4X, si possono acquisire immagini ingrandite fino a 12X volte per meglio adattarle al soggetto ed alla distanza. Lo zoom digitale è una funzione utile; tuttavia più un'immagine è ingrandita, più apparirà grossolana (pixel visibili).

3.1.9 Cambiare l'impostazione del fuoco



1. In modalità Istantanea premere il tasto [] per passare tra le seguenti modalità.

Icona	Fuoco	Descrizione
	Normale (AF)	Messa a fuoco automatica normale (50 cm - infinito).
[]	Macro	Messa a fuoco automatica Macro (6 cm). Il flash è impostato su [].
[]	Messa a fuoco panoramica (PF)	Questa opzione può diminuire i tempi di messa a fuoco e migliorare l'efficienza d'acquisizione delle immagini. Aiuta ad acquisire con facilità oggetti in rapido movimento o soggetti in ambienti bui. Profondità di campo in modalità [PF]: -Profondità di campo in Grandangolo. Con zoom obiettivo: 1m - 5m -Profondità di campo in Medio. Con zoom obiettivo: 1m - 4m -Profondità di campo in Teleobiettivo. Con zoom obiettivo: 1m - 3m

2. Comporre la fotografia.
3. Eseguire una mezza pressione del tasto otturatore e poi premerlo completamente.

3.1.10 Regolazione del valore d'esposizione EV

Il valore d'esposizione (EV) abilita a schiarire o scurire l'immagine. Usare questa impostazione quando la luminosità tra il soggetto e lo sfondo non è bilanciata, oppure quando il soggetto occupa solamente una piccola parte della fotografia.

1. In modalità Istantanea, assicurarsi che la modalità Scatto sia impostata su [Automatico] o [Manuale]. Per altre informazioni sull'impostazione della modalità Scatto, fare riferimento alla sezione 3.1.4 "Impostazione della modalità Scatto" a pagina 7.
2. Premere il tasto []. La barra di regolazione EV sarà visualizzata sulla parte inferiore del monitor LCD.
3. Per impostazione predefinita il valore EV è 0. Può essere regolato tra -2.0 e +2.0.
 - Per aumentare il valore EV, premere il tasto [] e poi premere il tasto **OK**.
 - Per diminuire il valore EV, premere il tasto [] e poi premere il tasto **OK**.

3.1.11 Menu Impostazioni della modalità Istantanea

3.1.11.1 Menu della modalità Istantanea

1. In modalità Istantanea, premere il tasto [MENU] per accedere al menu, e poi usare i tasti [ZOOM] / [OK] per selezionare le impostazioni del menu che si vogliono cambiare.
2. Usare i tasti [UP] / [DOWN] per selezionare l'elemento desiderato del menu, e poi premere il tasto OK.
3. Premere il tasto [MENU] per uscire dal menu.



Icona	Elemento	Opzione	Descrizione funzione
[Icona]	Dimens. imm.	[6M] 2816 x 2112 [4M] 2304 x 1728 [2M] 1600 x 1200 [1M] 1280 x 960 [VGA] 640 x 480	Imposta le dimensioni dell'immagine che sarà acquisita. Risoluzioni d'immagine più alte richiedono più quantità di memoria. Se si vogliono archiviare più immagini in una quantità limitata di memoria, usare una risoluzione d'immagine più bassa.
[Icona]	Qualità imm.	[★★★] Fine [★] Normale	Imposta la qualità (indice di compressione) con la quale è acquisita l'immagine.
[Icona]	Area AF	[C] Punto [Icona] Multipla	Determina come è selezionata l'area di fuoco.
[Icona]	Inter. scatti		Acquisisce le immagini in base alle impostazioni specificate. Per i dettagli fare riferimento alla sezione 3.1.11.2 "Uso della funzione Intervallo scatti" a pagina 12.
[Icona]	Stampa data	[ON] [OFF]	Stampa la data corrente nell'angolo in basso a destra delle immagini acquisite. Questa funzione deve essere attivata prima di acquisire l'immagine. Per altre informazioni sull'impostazione di data e ora, oppure sul formato della data, fare riferimento alla tabella nella sezione 3.4 "Modalità Impostazione" a pagina 19.
[Icona]	Bil. Bianco (Disponibile solamente in modalità Manuale)	[Icona] Automatico WB [Icona] Soleggiato [Icona] Nuvoloso [Icona] Tungsteno [Icona] Fluorescente	Imposta il bilanciamento del bianco quando si acquisiscono immagini in condizioni di luce specifiche <ul style="list-style-type: none"> - Automatico WB: regola automaticamente il bilanciamento del bianco - Soleggiato: impostazione adatta per condizioni di luce diurna. - Nuvoloso: impostazione adatta per condizioni di tempo nuvoloso, al crepuscolo o per condizioni d'ombra. - Tungsteno: impostazione adatta per condizioni per soggetti illuminati da illuminazione al tungsteno (incandescente). - Fluorescente: impostazione adatta per condizioni di illuminazione fluorescente.

Italiano

Icona	Elemento	Opzione	Descrizione funzione
	Misurazione (Disponibile solamente in modalità Manuale)	Media centr. Punto Media	Regola l'area del soggetto o dell'inquadratura nella quale la fotocamera misura la luce. <ul style="list-style-type: none"> Media centrale: la misurazione della fotocamera è impostata sulla luminosità media degli oggetti che si trovano nella zona centrale dell'inquadratura. Punto: la misurazione della fotocamera è impostata sulla luminosità degli oggetti che si trovano al centro dell'inquadratura. Media: la misurazione della fotocamera è impostata sulla luminosità media di tutti gli oggetti dell'inquadratura.
	Effetto	Normale B/N Seppia Vivido	Applica una tonalità o colore alle immagini per creare un effetto artistico. <ul style="list-style-type: none"> Normale: impostazione colore RGB standard adatta per fotografie generiche. B/N: fotografie in bianco e nero con gradazioni di grigio. Seppia: produce una foto dallo stile caldo ed antico nella quale i colori tendono più al marrone ed all'arancio. Vivido: produce colori più nitidi e vibranti.
	Imp. ISO (Disponibile solamente in modalità Manuale)	ISO Automatico ISO 100 ISO 200 ISO 400	Configura la sensibilità alla luce della fotocamera. <ul style="list-style-type: none"> ISO Automatico: imposta automaticamente il valore ISO. ISO 100: equivalente ad ISO 100 delle pellicole a colori. Usare questa impostazione per fotografie in esterni con luce del sole intensa. ISO 200: equivalente ad ISO 200 delle pellicole a colori. Usare questa impostazione per fotografie in esterni oppure in interni illuminati intensamente. ISO 400: equivalente ad ISO 400 delle pellicole a colori. Usare questa impostazione per soggetti in rapido movimento.

• **Impostazione del Bilanciamento del bianco**
 L'occhio umano si adatta ai cambiamenti di luminosità così che gli oggetti appaiono bianchi anche quando le condizioni di luce cambiano. Nelle fotocamere digitali il colore dei soggetti è influenzato dalle condizioni di luce che li circondano. Questa regolazione del colore è chiamata "regolazione del bilanciamento del bianco". L'impostazione permette di configurare il bilanciamento del bianco quando si acquisiscono immagini in condizioni di luce specifiche.

3.1.11.2 Uso della funzione Intervallo scatti

La fotocamera è in grado di eseguire l'acquisizione intervallata d'immagini in base all'impostazione. Questa modalità è disponibile con la funzione autoscatto. Si può specificare l'Intervallo(Intervallo) ed il numero d'immagini da acquisire.

Regolazione dell'Intervallo scatti:

- In modalità Istantanea, selezionare il menu Intervallo scatti.
- Usare i tasti / per passare tra Interval(Intervallo) e Count(Conteggio), e poi premere il tasto **OK**.
 - Interval(Intervallo):
 - [15 sec.]: l'intervallo di registrazione è di 15 secondi.
 - [1 min.]: l'intervallo di registrazione è di 1 minuto.
 - [3 min.]: l'intervallo di registrazione è di 3 minuti.
 - [10 min.]: l'intervallo di registrazione è di 10 minuti.
 - [60 min.]: l'intervallo di registrazione è di 60 minuti.





- Count(Conteggio): da 2 a 99 (specifica il numero di scatti che possono essere acquisiti).
- Usare i tasti []/[] per regolare le impostazioni, e poi premere il tasto **OK**.

Acquisizione delle immagini con la funzione Intervallo scatti:

- In modalità Istantanea, premere il tasto [] per selezionare la modalità Intervallo scatti.
- Premere il tasto Otturatore per avviare. Le immagini saranno acquisite in base all'Interval(Intervallo) e Count(Conteggio) impostati.
- Premere il tasto Otturatore per terminare.

3.2 Modalità Film

Grazie alla funzione della fotocamera, sviluppata specificatamente per sospendere la registrazione, la sessione di registrazione può essere messa in pausa ogni volta desiderato per meglio soddisfare le proprie necessità. Familiarizzare con questa funzione attenendosi alle semplici fasi che seguono.

- Premere il tasto [] per accedere alla modalità Film. È visualizzata la schermata di registrazione sequenza video.
- Inquadrare il soggetto nel display LCD usando il tasto zoom, se desiderato.
 - Lo zoom ottico deve essere impostato prima di avviare la registrazione.
 - Lo zoom ottico non può essere usato durante la registrazione.
- Premere il tasto Otturatore per avviare la registrazione.
 - Premere di nuovo il tasto otturatore per fermare la sessione di registrazione.
 - Premere il tasto **OK** per mettere in pausa la sessione di registrazione. Premere di nuovo il tasto **OK** per riprendere la registrazione.



- **Il flash non può essere usato in modalità Film.**
- **La compensazione EV non può essere impostata o attivata in modalità Film.**
- **Durante la registrazione di un video su scheda SD, non aprire il coperchio dello scomparto batterie / scheda SD e non rimuovere la batteria o la scheda SD. Diversamente si danneggia la scheda memoria SD o si distruggono i dati.**
- **La lunghezza della registrazione dipende dalla quantità di memoria disponibile nella scheda memoria oppure nella memoria integrata della fotocamera. Il tempo residuo è visualizzato nell'angolo in alto a destra del monitor LCD.**



Italiano

3.2.1 Informazioni del monitor LCD in modalità Film

- Modalità Film
- Tempo di registrazione disponibile
- Qualità film
- Stato dello zoom
- Indicatore di carica della batteria

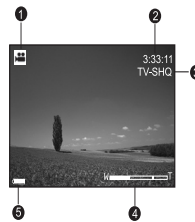

3.2.2 Menu Impostazioni della modalità Film

3.2.2.1 Menu della modalità Film







1. In modalità Film, premere il tasto [MENU] per accedere al menu, e poi usare i tasti [←] / [→] / [OK] per selezionare le impostazioni del menu che si vogliono cambiare.
2. Usare i tasti [↑] / [↓] per selezionare l'elemento desiderato del menu, e poi premere il tasto **OK**.
3. Premere il tasto [MENU] per uscire dal menu.



Icona	Elemento	Opzione	Descrizione funzione
[Icona]	Qualità film	<ul style="list-style-type: none"> TV-SHQ TV-HQ TV-S Web-HQ Web-S 	<p>Imposta la qualità e le dimensioni della sequenza video che sarà registrata.</p> <ul style="list-style-type: none"> - TV-SHQ: 640 x 480 - TV-HQ: 640 x 480 - TV-S: 320 x 240 - Web-HQ: 320 x 240 - Web-S: 160 x 128 <p> "SHQ" si riferisce a "Super High Quality" (qualità eccellente). "HQ" si riferisce a "High Quality" (alta qualità). "S" si riferisce a "standard".</p>
[Icona]	Bil. Bianco	<ul style="list-style-type: none"> Automatico WB Soleggiato Nuvoloso Tungsteno Fluorescente 	<p>Imposta il bilanciamento del bianco quando si registrano soggetti in condizioni di luce specifiche.</p> <ul style="list-style-type: none"> - Automatico WB: regola automaticamente il bilanciamento del bianco. - Soleggiato: impostazione adatta per condizioni di luce diurna. - Nuvoloso: impostazione adatta per condizioni di tempo nuvoloso, al crepuscolo o per condizioni d'ombra. - Tungsteno: impostazione adatta per condizioni per soggetti illuminati da illuminazione al tungsteno (incandescente). - Fluorescente: impostazione adatta per condizioni adatta per soggetti illuminati da illuminazione fluorescente.
[Icona]	Effetto	<ul style="list-style-type: none"> <input checked="" type="checkbox"/> Normale B/N Seppia Vivido 	<p>Imposta il colore della sequenza video che sarà registrata.</p> <ul style="list-style-type: none"> - Normale: impostazione colore RGB standard adatta per registrazioni generiche. - B/N: sequenze video in bianco e nero con gradazioni di grigio. - Seppia: Produce sequenze video dallo stile caldo ed antico nella quale i colori tendono più al marrone ed all'arancio. - Vivido: Produce colori più nitidi e vibranti.
[Icona]	Timer REC	Imposta	<p>Consente di impostare anticipatamente le sessioni di registrazione. Per altre informazioni sull'impostazione del Timer registrazione, fare riferimento alla sezione 3.2.3 "Timer registrazione" a pagina 15.</p>

3.2.3 Timer registrazione



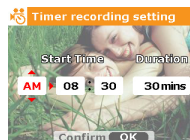

Grazie alla funzione speciale "Timer registrazione", si possono impostare in anticipo le sessioni di registrazione; attenersi alle fasi che seguono.

1. In modalità Film, premere il tasto [] per accedere al menu, e poi scorrere a [Timer REC].
2. Premere [].
È visualizzata la schermata [Timer recording setting] (Impostazione timer registrazione).
3. Premere i tasti []/[] per impostare ciascun elemento.
Premere []/[] per passare all'elemento successivo.
4. Dopo avere impostato Start Time(Ora inizio) e Duration(Durata), premere il tasto **OK** per confermare.
5. È visualizzata la schermata [Timer recording Standby] (Standby timer registrazione). Premere il tasto zoom per regolare la distanza.
 - Premere il tasto otturatore per attivare l'impostazione.
 - Premere il tasto [] per uscire.
6. È visualizzata la schermata [Timer Recording] (Timer registrazione). La fotocamera accede alla modalità di Standby e mostra le informazioni della sessione. Premere il tasto otturatore per annullare l'operazione.
7. La fotocamera accede alla modalità di registrazione quando la sessione di registrazione è avviata. Al completamento della sessione di registrazione la fotocamera si spegnerà automaticamente.



3.3 Modalità Riproduzione

In modalità Riproduzione si può prendere visione, ingrandire, ridimensionare, ritagliare ed eliminare le immagini, si possono eseguire sequenze video, registrare promemoria vocali o effettuare presentazioni. Questa modalità fornisce anche la visualizzazione delle immagini in miniatura, che consente di trovare rapidamente l'immagine desiderata.

1. Premere il tasto [] per accedere alla modalità Riproduzione.
2. Usare i tasti []/[] per selezionare le immagini desiderate.
 - Premere il tasto [] per vedere l'immagine precedente.
 - Premere il tasto [] per vedere l'immagine successiva.

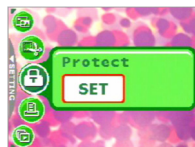

3.3.1 Informazioni del monitor LCD in modalità Riproduzione (Immagine)

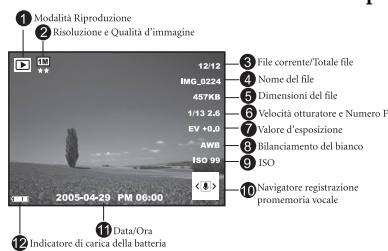

3.3.2 Prendere visione delle immagini

3.3.2.1 Ingrandimento delle immagini

Mentre si prende visione delle immagini, si può ingrandire una porzione selezionata dell'immagine. Questo ingrandimento permette di visualizzare i dettagli dell'immagine. La fotocamera fornisce funzioni di zoom digitale 4X durante la riproduzione.

1. Impostare la percentuale dello zoom usando il tasto zoom.
 - Per ingrandire, regolare il tasto zoom sulla destra.
 - Per ridurre, regolare il tasto zoom sulla sinistra.
 - La percentuale dello zoom è visualizzata sullo monitor LCD.

2. Per vedere varie porzioni delle immagini, premere i tasti [ZOOM] / [ZOOM] / [ZOOM] / [ZOOM] per regolare l'area di visualizzazione.

Si vedrà una cornice con un riquadro al suo interno. La cornice rappresenta l'intera immagine, mentre il riquadro mostra la posizione dell'area correntemente ingrandita.

3. Per tornare alla visualizzazione regolare, premere il tasto zoom finché sullo schermo appare l'immagine a dimensioni normali (ingrandimento 1X). Oppure, premere il tasto [MENU] per uscire direttamente.



Italiano

- Se nella memoria interna o nella scheda memoria non è archiviata alcuna immagine, sul monitor LCD apparirà il messaggio [No File!(Nessun file)].
- La pressione del tasto [MENU] durante la riproduzione fa cambiare il display LCD nella seguente sequenza: OSD normale → Informazioni dettagliate → Informazioni disattivate.

3.3.2.2 Visualizzazione miniature (Riproduzione indice)

Questa funzione consente di visualizzare sul monitor LCD simultaneamente nove immagini in miniatura, così da poter trovare facilmente l'immagine voluta.

1. Regolare il tasto zoom sulla sinistra.
Sono visualizzate simultaneamente nove immagini in miniatura.
2. Usare i tasti []/[]/[]/[]/[] per selezionare l'immagine da visualizzare a dimensioni regolari, e poi premere il tasto **OK** per visualizzare l'immagine selezionata a schermo intero.



3.3.2.3 Promemoria vocale

L'aggiunta di un promemoria vocale è un modo utile per aggiungere note e promemoria alle immagini.

1. Selezionare un'immagine in modalità Riproduzione. Nell'angolo in basso a destra del monitor LCD è visualizzata l'icona []].
2. Premere il tasto **OK** per avviare la registrazione. Sul monitor LCD è visualizzato il tempo trascorso. Ora si può aggiungere a ciascuna immagine un promemoria vocale della durata massima di 20 secondi.
3. Premere di nuovo il tasto **OK** per terminare la registrazione.
4. Premere di nuovo il tasto **OK** per eseguire il promemoria vocale.
5. Se si vuole eliminare il promemoria vocale, premere il tasto []], scegliere [Delete Voice(Elimina voce)], e poi premere il tasto **OK**.

3.3.3 Eliminazione dei file

Quando non si è soddisfatti delle immagini, sequenze video o promemoria vocali, si può scegliere di eliminarne uno per volta o tutti insieme. Si prega di notare che i file eliminati non possono essere recuperati.

1. In modalità Riproduzione, premere il tasto []] per eliminare i file.
 - Scegliere [Delete One(Elimina uno)] e premere il tasto **OK** per eliminare il file corrente.
 - Scegliere [Delete All(Elimina tutto)] e premere il tasto **OK** per eliminare tutti i file.
 - Scegliere [Delete Voice(Elimina voce)] e premere il tasto **OK** se si vuole eliminare un'immagine che contiene un promemoria vocale.
 - Scegliere [Exit(Esci)] per annullare l'operazione.

☞ • I file protetti non possono essere eliminati.

3.3.4 Menu Impostazioni della modalità Riproduzione

3.3.4.1 Menu della modalità Riproduzione

1. Premere il tasto []] per accedere alla modalità Riproduzione.
2. Premere il tasto []] per accedere al menu, e poi usare i tasti []/[]/[] per selezionare le impostazioni del menu che si vogliono cambiare.
3. Usare i tasti []/[] per selezionare l'elemento desiderato del menu, e poi premere il tasto **OK**.

4. Premere il tasto [MENU] per uscire dal menu.

Icona	Elemento	Opzione	Descrizione funzione
	Protezione	[SET]	<p>Configura i dati sull'impostazione di sola lettura per prevenirne la cancellazione accidentale.</p> <p>Attenersi alle fasi che seguono per proteggere i file.</p> <ol style="list-style-type: none"> 1. Premere [SET] quando è visualizzato il menu [Protezione]. 2. Si può anche scegliere di proteggere o togliere la protezione ai file facendo come segue. <ul style="list-style-type: none"> - Scegliere [Protect One(Proteggi uno)] e premere il tasto OK per proteggere il file correntemente selezionato. Se si vuole annullare la protezione del file corrente, scegliere [Unprotect One(Togli prot. a uno)] e premere il tasto OK. - Scegliere [Protect All(Proteggi tutto)] e premere il tasto OK per proteggere tutti i file. Se si vuole annullare la protezione a tutti i file, scegliere [Unprotect All(Togli pr. a tutto)] e premere il tasto OK. - Per uscire dal menu premere il tasto [Esci]. <p> Se il file è protetto sarà visualizzata l'icona </p>
	Regola	[SET]	<p>Consente di ritagliare una porzione di una immagine acquisita.</p> <p>Attenersi alle fasi che seguono per ritagliare una immagine acquisita.</p> <ol style="list-style-type: none"> 1. In modalità Riproduzione, scegliere Ritaglia e poi premere [SET]. 2. Usare il tasto zoom e i tasti per spostarsi nell'area voluta. 3. Premere il tasto OK. <p> Un'immagine ritagliata sarà salvata come un altro file ed avrà dimensioni più piccole.</p>
	Presentazione	[1] 1 sec. [3] 3 sec. [5] 5 sec.	<p>Questa funzione abilita ad impostare l'intervallo durante la riproduzione automatica in sequenza delle immagini come una presentazione. Questa funzione è molto utile e divertente per rivedere le immagini acquisite e per eseguire presentazioni.</p> <p>Una volta selezionata una opzione, la presentazione si avvia immediatamente. Per fermarla basta premere il tasto OK.</p>
	Ridimensiona	[2048] 2048 x 1536 [1600] 1600 x 1200 [1280] 1280 x 960 [640] 640 x 480	<p>Consente di cambiare le dimensioni di una immagine acquisita.</p> <p>Attenersi alle fasi che seguono per ridimensionare una immagine acquisita.</p> <ol style="list-style-type: none"> 1. In modalità Riproduzione, scegliere Ridimensiona e poi premere selezionare l'opzione desiderata. 2. Premere il tasto OK. <p> Un'immagine ridimensionata sarà salvata come un altro file ed avrà dimensioni più piccole.</p>





3.3.5 Informazioni del monitor LCD in modalità Riproduzione (Video)

1. Modalità Riproduzione
2. File attuale/Totale file
3. Nome del file
4. Dimensioni del file
5. Navigatore di riproduzione
6. Data/Ora
7. Indicatore di carica della batteria



3.3.6 Riproduzione di sequenze video

In modalità Riproduzione, usare il di riproduzione  , nell'angolo in basso a destra del monitor LCD, per controllare la riproduzione delle sequenze video.

- Premere il tasto **OK** per avviare la riproduzione di una sequenza video.
 - Premere il tasto **OK** per mettere in pausa o riprendere la riproduzione video.
 - Premere il tasto  per terminare la riproduzione video.
 - Premere il tasto  per riprodurre la sequenza video al rallentatore.
 - Premere il tasto  per far avanzare rapidamente la riproduzione video.
 - Premere il tasto  per far retrocedere rapidamente la riproduzione video.
-  • **La funzione zoom non può essere attivata durante l'esecuzione di sequenze video.**

3.4 Modalità Impostazione







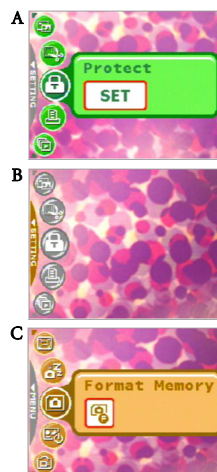





















Si può accedere alla modalità Impostazione indifferentemente dalla modalità correntemente in uso. Con questa modalità si possono selezionare le proprie preferenze per la fotocamera.

3.4.1 Menu modalità Impostazione

1. In qualsiasi modalità (Istantanea, Film o Riproduzione), premere il tasto [MENU] (Fase **A**).
2. Premere due volte il tasto [OK] per **accedere** alla modalità Impostazione (Fase **B** e Fase **C**).
3. Usare i tasti [ZOOM] / [OK] per selezionare le impostazioni del menu che si vogliono cambiare.
4. Usare i tasti [OK] / [ZOOM] per selezionare l'elemento desiderato del menu, e poi premere il tasto **OK**.
5. Premere due volte il tasto [OK] per uscire dal **menu**.



Icona	Elemento	Opzione	Descrizione funzione
[Icona Memoria]	Memoria	[Icona Formatta mem.] Formatta mem.	<ul style="list-style-type: none"> - [Formatta mem.]: questa opzione è visualizzata quando la scheda memoria SD non è installata. Cancella tutti dati e formatta la memoria interna. Sono cancellati anche i file protetti.
[Icona Memoria]	Memoria	[Icona Copia su sch.] Copia su sch. [Icona Formatta SD] Formatta SD	<ul style="list-style-type: none"> - [Copia su sch.]: questa opzione è visualizzata quando la scheda memoria SD è installata. Si possono copiare i file dalla memoria interna della fotocamera ad una scheda SD installata - [Formatta SD]: questa opzione è visualizzata quando la scheda memoria SD è installata. Cancella tutti dati della scheda memoria SD e formatta la scheda. Sono cancellati anche i file protetti. Una scheda SD non può essere formattata se è protetta da scrittura. <p>Questo menu è disponibile solo quando si inserisce una scheda di memoria SD.</p>

Icona	Elemento	Opzione	Descrizione funzione
	Imm. d'avvio		<p>Attendersi alle fasi che seguono per impostare l'immagine d'avvio che è visualizzata quando si accende la fotocamera.</p> <ol style="list-style-type: none"> 1. Selezionare , quindi sarà richiesto di selezionare l'immagine d'avvio. Usare i tasti  /  /  /  per selezionare l'immagine preferita.  <ol style="list-style-type: none"> 2. Se non si è soddisfatti delle immagini predefinite, ci si può portare all'angolo in basso a destra del monitor LCD per personalizzare l'immagine d'avvio selezionando le immagini di proprio piacimento. 3. Dopo avere seguito la selezione, premere il tasto OK per confermare e poi premere  per uscire.
	Risp. energ.	   	<p>Se, durante l'accensione, la fotocamera resta inutilizzata per un determinato periodo di tempo, passerà alla modalità di risparmio energia in base alle impostazioni configurate. Se la fotocamera è in stato di risparmio energia, premere qualsiasi tasto per riattivarla.</p> <ul style="list-style-type: none"> - Disattiva/30 sec./1 min./3 min. <p> Se la fotocamera è rimasta inattiva per più di 5 minuti, si spegne automaticamente.</p>
	Vista rapida	 	<p>Consente di ottenere un'anteprima rapida dell'immagine subito dopo averla acquisita. L'anteprima dura brevemente e dopo si può continuare ad acquisire altre immagini.</p> <ul style="list-style-type: none"> - Attiva/Disattiva
	Zoom digitale	 	<p>Consente di attivare o disattivare lo zoom digitale in base alle proprie preferenze.</p> <ul style="list-style-type: none"> - Attiva/Disattiva
	Vol. riprod.		<p>Consente di regolare il volume delle sequenze video o dei promemoria vocali. Il livello del volume si imposta con i tasti  / .</p>
	Sonoro sist.	 	<p>Consente di attivare e disattivare gli effetti sonori del sistema, come l'avviso emesso quando preme un tasto o si scorre.</p>

Icona	Elemento	Opzione	Descrizione funzione
	Accensione	ON OFF	<p>Consente di attivare o disattivare la funzione d'accensione con i tasti Registrazione immediata ed Esecuzione immediata.</p> <p>[On] (Attiva): abilita la funzione d'accensione della fotocamera con i tasti Registrazione immediata ed Esecuzione immediata.</p> <p>[Off] (Disattiva): disabilita la funzione d'accensione della fotocamera con i tasti Registrazione immediata ed Esecuzione immediata.</p>
	Lumin. LCD	Normale Luminoso	<p>Consente di impostare la luminosità del monitor LCD su Normale o Luminoso.</p>
	Data/Ora		<p>Consente di regolare la date e l'ora.</p> <ol style="list-style-type: none"> Usare i tasti / per selezionare l'elemento che si vuole cambiare. Premere il tasto OK ed usare i tasti / / / per regolare l'impostazione. <p>L'impostazione di data e ora è importante perché queste informazioni sono archiviate insieme alle immagini acquisite, e sono utilizzate quando è attivata la funzione Stampa data. Impostare data e ora prima di utilizzare la fotocamera per la prima volta.</p>
	Formato data	YMD MDY DMY	<p>Consente di selezionare il formato della data per la funzione [Stampa data].</p> <ul style="list-style-type: none"> Anno - Mese - Data Mese - Data - Anno Data - Mese - Anno
	Uscita video	NTSC PAL	<p>La porta uscita TV della fotocamera fornisce l'output video per visualizzare le immagini o le sequenze video su uno schermo TV standard. Impostare la modalità d'uscita video su NTSC o PAL. Fare riferimento alle autorità locali per informazioni su quale sistema, NTSC o PAL, è in uso nella propria zona.</p>
	Lingua		<p>Consente di impostare la lingua che è visualizzata sul monitor LCD.</p>
	Reset	Ripr. n. file Ripr. predef.	<ul style="list-style-type: none"> [Ripr. n. file]: La fotocamera assegna automaticamente dei numeri crescenti ai nomi dei file di tutte le immagini, sequenze video e promemoria vocali che sono stati registrati. Si può scegliere di ripristinare la numerazione automatica partendo da 1. [Ripr. predef.]: selezionando questa funzione, tutte le impostazioni della fotocamera sono ripristinate sui valori predefiniti.
	Ver. software		<p>Visualizza il numero di versione del firmware installato.</p>

4 FUNZIONI CHE DIPENDONO DAL PC

4.1 Pacchetto software

La fotocamera è fornita con il seguente software: Fare riferimento alle informazioni allegate ai relativi CD per installare il software.

Ulead Photo Express

Ulead® Photo Express™ 5.0 SE è un software completo per le immagini digitali. Acquisizione senza difficoltà da fotocamere digitali o scanner. Modifica e miglioramento delle immagini grazie agli strumenti di facile utilizzo ed ai filtri ed effetti fotografici. Creazione di progetti fotografici creativi e condivisione dei risultati via posta elettronica ed opzioni multiple di stampa.

Ulead Photo Explorer

Ulead® Photo Explorer™ 8.0 SE Basic fornisce un mezzo efficiente per trasferire, consultare, modificare e distribuire i supporti digitali. È lo strumento completo per i titolari di fotocamere digitali, Webcam, videocamere DV, scanner o per chiunque fatichi a gestire con efficienza i supporti digitali.

Ulead VideoStudio

Ulead® VideoStudio™ 8 SE VCD è un software d'elaborazione video che rende la modifica dei filmati divertente come la loro ripresa. L'utente può creare un filmato in tre semplici passaggi usando la nuova procedura guidata Movie Wizard. I progetti completati possono essere condivisi su VCD, nastro, sul Web e su dispositivi mobili.

4.2 Modalità USB

1. Collegare lo spinotto più piccolo del cavo USB alla fotocamera.
2. Collegare l'altra estremità del cavo USB in una porta USB disponibile del computer.
3. Accendere la fotocamera. È visualizzata la schermata USB
4. Nelle "Risorse del computer" appare un "Disco rimovibile". Fare clic su questa icona per accedere alle proprie immagini o sequenze video.



- Se collegata a un computer, è necessario inserire una batteria.



4.3 Modalità Stampante

Se è disponibile una stampante che supporta la funzione PictBridge, le immagini possono essere stampate senza usare un computer collegando la fotocamera direttamente alla stampante compatibile PictBridge.

Collegamento della fotocamera ad una stampante compatibile PictBridge

1. Collegare la fotocamera alla stampante usando il cavo USB fornito in dotazione, e poi accendere la fotocamera.
2. Seleziona [Printer] (Stampante).



- Se non è eseguita alcuna selezione entro 10 secondi, sarà attivata la funzione [Mass Storage] (Archiviazione di massa) (e.g. disco rigido esterno).
3. Quando la connessione è stata stabilita, sarà richiesto di selezionare [Print One] (Stampa uno), [Print All] (Stampa tutto) o [Print Index] (Stampa indice). Selezionare l'opzione desiderata e premere il tasto **OK**.
 4. Sulla parte inferiore del monitor LCD saranno visualizzate le opzioni [Setup] (Impostazione), [Print] (Stampa) ed [Exit] (Esci).
 - Se si seleziona [Setup] (Impostazione), sarà visualizzata la schermata [PictBridge setup] (Impostazione PictBridge). Se desiderato si possono impostare le opzioni [Copies] (Copie), [Size] (Dimensioni) e [Quality] (Qualità).
 - Se si è soddisfatti delle impostazioni, selezionare [Print] (Stampa) per procedere.
 - Selezionare [Exit] (Esci) per annullare.



- Le funzioni descritte sopra potrebbero differire in base al modello della stampante con cui si effettua la connessione.



5 RISOLUZIONE DEI PROBLEMI

Fare riferimento ai problemi ed alle loro soluzioni, elencate di seguito, prima di inviare la fotocamera per riparazioni. Se il problema persiste, mettersi in contatto con il rivenditore oppure con il Centro assistenza locale.

Problema	Causa	Soluzione
Impossibile accendere la fotocamera.	Manca la batteria oppure la batteria non è inserita correttamente.	Inserire correttamente la batteria.
	La batteria è scarica.	Ricaricare la batteria.
La batteria si scarica rapidamente.	La temperatura esterna è troppo bassa.	—
	Molti scatti sono stati eseguiti in ambienti bui che hanno richiesto l'uso del flash.	—
	La batteria non è stata caricata completamente. La batteria non è stata utilizzata per un lungo periodo dopo essere stata caricata.	Caricare e scaricare completamente la batteria almeno una volta prima dell'uso.
La batteria della fotocamera è calda.	Il flash della fotocamera è stato usato in modo continuato per un periodo prolungato.	—
Il flash non si attiva. Il flash non si ricarica.	Il flash della fotocamera è disattivato.	Impostare il flash su Automatico.
	La sorgente luminosa è sufficiente.	—
L'immagine è scura sebbene il flash si sia attivato.	La distanza dal soggetto è superiore alla portata effettiva del flash.	Avvicinarsi al soggetto e poi scattare.
L'immagine è troppo chiara o troppo scura.	L'esposizione è eccessiva o inadeguata.	Ripristinare la compensazione d'esposizione.
Impossibile formattare la scheda memoria.	La scheda memoria è protetta da scrittura.	Rimuovere la protezione scrittura.
	La durata utile della scheda memoria è terminata.	Inserire una nuova scheda memoria.

Problema	Causa	Soluzione
Impossibile scaricare le immagini.	Lo spazio libero sul disco rigido del computer non è sufficiente.	Assicurarsi che il disco rigido abbia spazio sufficiente per eseguire Windows e che l'unità per il caricamento dei file immagine possieda uno spazio uguale o superiore a quello della scheda memoria nella fotocamera.
	Non è fornita alimentazione alla fotocamera.	Ricaricare la batteria.
La fotocamera non scatta anche se si preme il tasto otturatore.	La batteria si sta scaricando.	Ricaricare la batteria.
	La fotocamera non è in modalità Scatto.	Passare alla modalità Scatto.
	Il tasto otturatore non è stato premuto fino in fondo.	Premere fino in fondo il tasto otturatore.
	La memoria interna o la scheda memoria non ha più spazio libero.	Installare una nuova scheda oppure eliminare i file indesiderati.
	Il flash si sta caricando.	Attendere finché l'icona della modalità flash, che appare sullo schermo, smette di lampeggiare.
Impossibile stampare immagini con stampanti compatibili PictBridge.	La fotocamera non riconosce la scheda memoria.	Formattare la scheda memoria prima dell'uso iniziale oppure prima di usarla con un'altra fotocamera.
	Al momento del collegamento alla stampante la fotocamera era spenta.	Accendere la fotocamera, selezionare PictBridge e poi collegarla alla stampante.

6 SPECIFICHE

Sensore immagine	CCD 1/2,5 pollici
	Pixel effettivi: 6,19 Mega Pixel
Display LCD	LCD LPTS a colori, 2,4 pollici (480 x 234 Mega Pixel)
Obiettivo	Lunghezza di fuoco: $f = 5,8 - 17,4$ mm (equivalente a 35 mm - 105 mm; 35 mm)
	Fuoco: F2,8/F4,8
Messa a fuoco	Fuoco automatico TTL
	Portata: Macro: 6 cm, Normale: 60 cm ~ infinito
Otturatore	Otturatore meccanico: fino a 1/2000 di secondo
Modalità di scatto	Automatico/Manuale/Ritratto/Paesaggio/Notte/Sport/Controluce/Ritratto notturno
Flash	Modalità: Automatico/Flash forzato/Riduzione effetto occhi rossi/Flash disattivo/Sincronia rallentata
	Portata: 0,5 ~ 2,0m
Autoscatto	10 secondi, 2 secondi
Esposizione	Compensazione: ± 2 EV (incrementi 1/3 EV)
ISO	Automatico/100/200/400
Bilanciamento del bianco	Automatico/Soleggiato/Nuvoloso/Tramonto/Tungsteno/Fluorescente
Formato file	Fotografia: formato JPEG (EXIF2.2), DCF Dimensioni immagine: 2816 x 2112, 2304 x 1728, 1600 x 1200, 1280 x 960, 640 x 480 pixel
	Sequenze filmate: Formato AVI Motion-JPEG con registrazione continua. Dimensioni filmato: 640 x 480, 320 x 240, 160 x 128 pixel (30 fps)
Archivio	Memoria integrata: 24 MB / compatibile scheda memoria SD.
Riproduzione immagini	Immagine singola / esecuzione AVI / Miniature / Presentazione
Interfaccia	Rendimento digitale: USB Output Audio/Video (NTSC/PAL)
Alimentazione	Batteria ricaricabile agli ioni di litio
Dimensioni (larghezza x altezza x profondità)	92 x 60 x 24,5 mm
Peso	Approssimativamente 135+/-10 g (senza batteria, scheda memoria SD)

Requisiti del sistema (per Windows)

* CPU Pentium 166 Mhz o superiore * 64 MB di RAM * Unità CD-ROM	* Windows XP/ME/2000 * 128 MB di spazio libero su disco * Porta USB disponibile
---	---