

MICROPHONE MIXER

MX-510

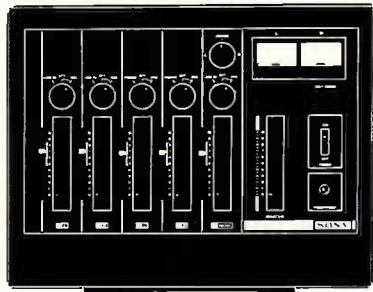

Owner's instruction manual

Read this manual thoroughly and retain for future reference.

Mode d'emploi

Lisez ce mode d'emploi avec soin et conservez-le pour toute référence ultérieure.

Bedienungsanleitung

Lesen Sie diese Anleitung sorgfältig durch und bewahren Sie sie auf, um später jederzeit darin nachschlagen zu können.

BLOCK DIAGRAM / SCHEMA DE PRINCIPE / BLOCKSCHALTPLAN

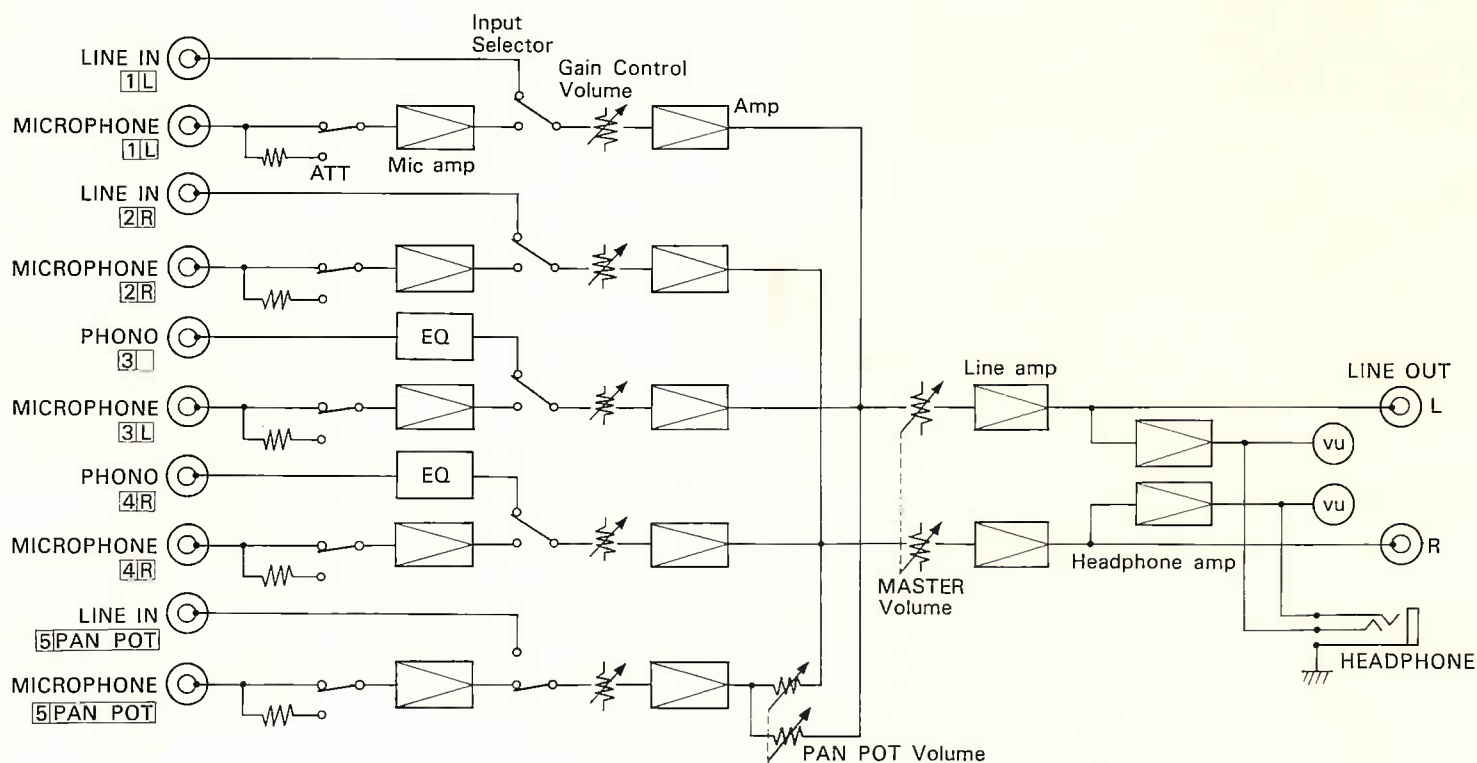

Slim, portable, easy-to-operate...the Sony MX-510 is an ideal electronic microphone mixer which incorporates convenient switch circuitry in a functional layout.

The MX-510 can mix up to five channels of input and provide two channels of output for creative mixing results.

FEATURES

2-way powering system: The MX-510 operates on either internal batteries or AC house current (with the Power Adaptor AC-12).

Pan-pot control: For panning the sound image to the desired portion between L and R channels.

Mic attenuators: For reducing excessive mic input level which could cause mic amplifier distortion.

WARNING

- To avoid electrical shock, do not open the cabinet. Refer servicing to qualified personnel only.
- To prevent fire or shock hazard, do not expose the set to rain or moisture.

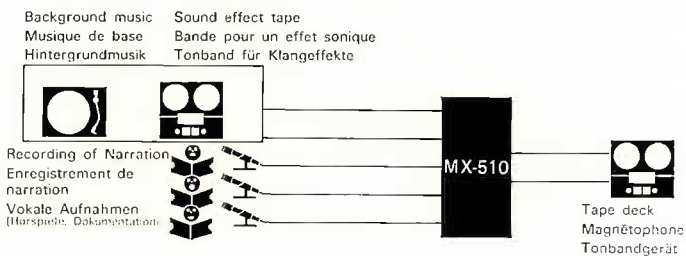
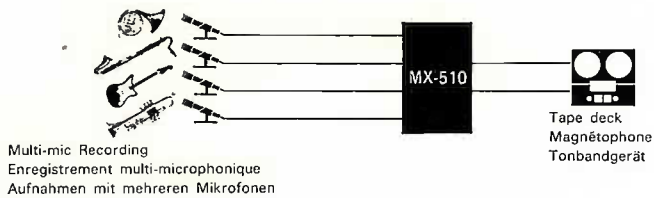
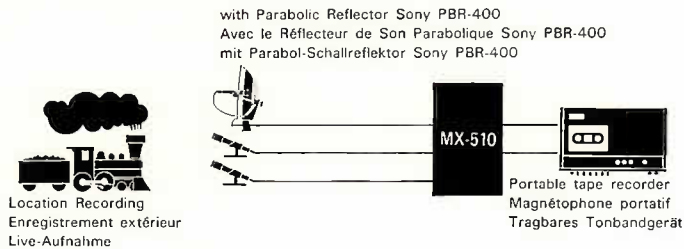

TABLE OF CONTENTS

BLOCK DIAGRAM.....	front cover
FEATURES.....	2
WARNING	2
POWER SOURCES.....	4
FUNCTION AND LOCATION OF PARTS AND CONTROLS	6
CONNECTION DIAGRAM	10
OPERATING PROCEDURE	10
SPECIFICATIONS.....	back cover

POWER SOURCES

BATTERIES

1. Remove the battery lid as illustrated and insert the batteries (eight, size "C" cells) into the battery compartment.

● Refer to the battery polarity indication in the compartment.

2. Replace the battery lid.

Battery Life

When the battery life is reduced to a certain degree, the tone quality of the mixing sounds will be degraded.

Before starting a valuable mixing recording, check the battery condition as follows:

1. Turn on the POWER switch.
2. Depress the BATT CHECK button. The right Level Meter will indicate the battery condition.

If the meter does not remain within the black BATT line, replace all 8 batteries.

Sony super size "C" batteries (eight) will supply approx. 60 hours of continuous operation with the MX-510.

● Turn off the POWER switch to avoid unnecessary battery consumption when the MX-510 is not to be used.

● When the mixer is not to be used for a long period of time or is operated on house current, remove the batteries to avoid battery leakage.

● Use fresh batteries. If possible, test the battery condition before purchasing.

● Keep the batteries in a cool place.

AC HOUSE CURRENT

Use the Sony AC Power Adaptor AC-12 (optional).

When the power adaptor is connected, battery power is automatically disconnected. For detailed operation of the adaptor, refer to its instruction manual.

● Remove the batteries to avoid battery leakage when the adaptor is to be used for a long time.

● Disconnect the adaptor when the MX-510 is not in use.

Note

The POWER switch will be automatically turned off when the lid is closed, even with the POWER switch on.

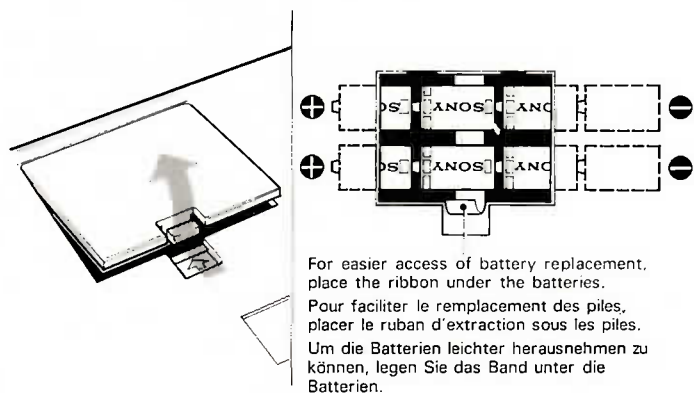

For easier access of battery replacement, place the ribbon under the batteries.
Pour faciliter le remplacement des piles, placer le ruban d'extraction sous les piles.
Um die Batterien leichter herausnehmen zu können, legen Sie das Band unter die Batterien.

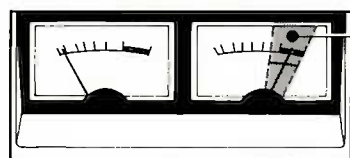

Good condition
Bon état des piles
Guter Zustand

BATT CHECK

Ⓞ Depress/ Appuyer/ Drücken

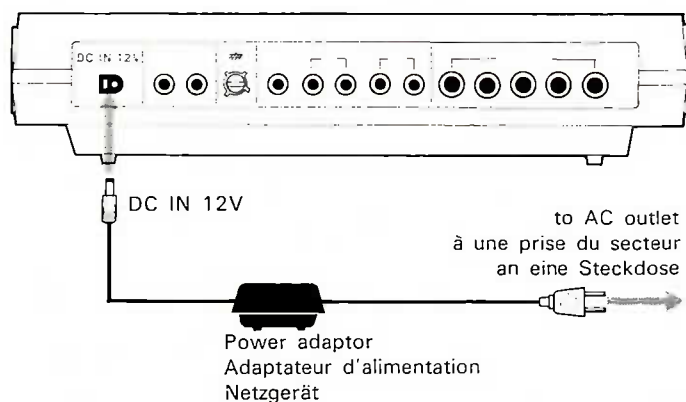

FUNCTION AND LOCATION OF PARTS AND CONTROLS

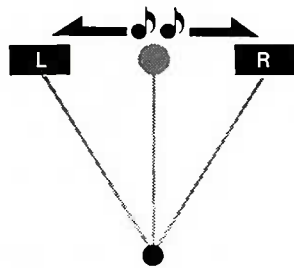
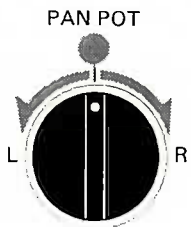
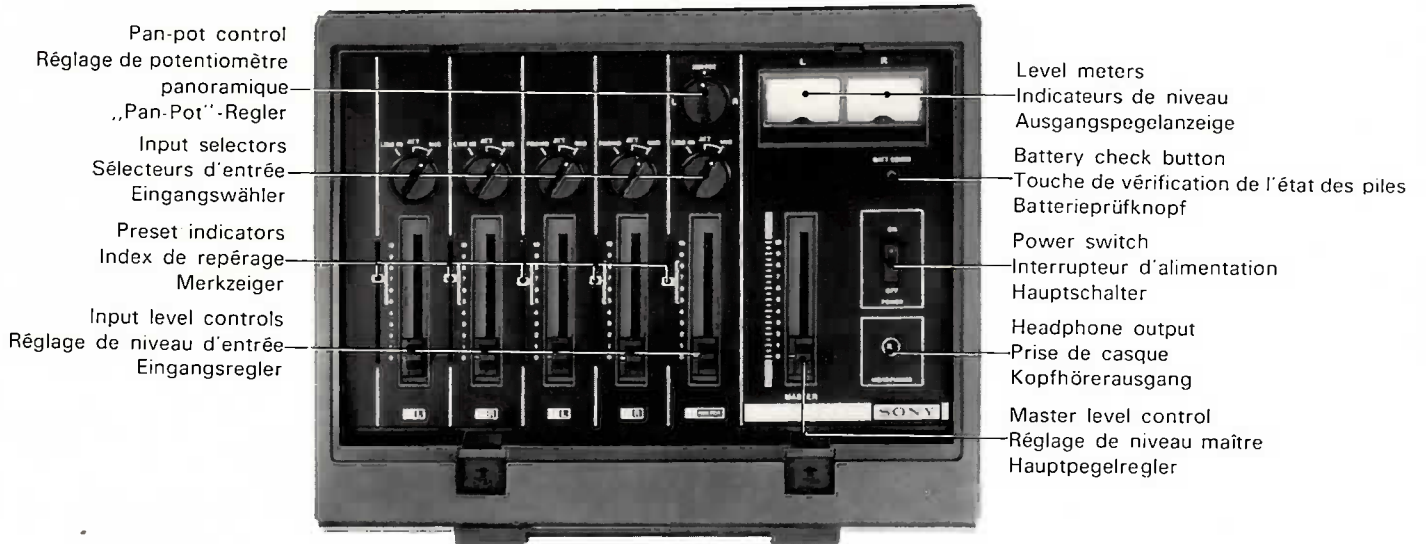

Pan-pot control (Panoramic Potentiometer) [PAN POT]

Allows the acoustical positioning of channel 5 input signal between the Left and Right channel output. The center click position directs the signal to the center position of L and R outputs, at the same level. This facilitates "center-mixing" of a mono source such as announcements or solo playing between channels.

Input selectors [INPUT SELECT]

Select the inputs connected to the same input channel.

LINE IN.....Inputs (such as tuner, tape recorder, etc.) connected to the LINE IN jacks (channels 1, 2 and 5).

PHONO.....Record player connected to the PHONO jacks (channels 3 and 4).

MIC.....Mics connected to the MICROPHONE jacks (channels 1 to 5).

ATT.....This position is useful to avoid overload distortion of mic amplifier when recording a large input signal on location (rock music, etc.) or recording with mic too close to the source. (At this position the mic level is reduced by 20 dB). Use this position when the meter repeatedly reads over "0" with the Input Level Control set around the "3" position or below.

Preset indicators

Use as a reference point when temporary level changes are necessary.

FONCTION ET EMPLACEMENT DES COMMANDES

FUNKTION UND LAGE DER TEILE UND BEDIENUNGSELEMENTE

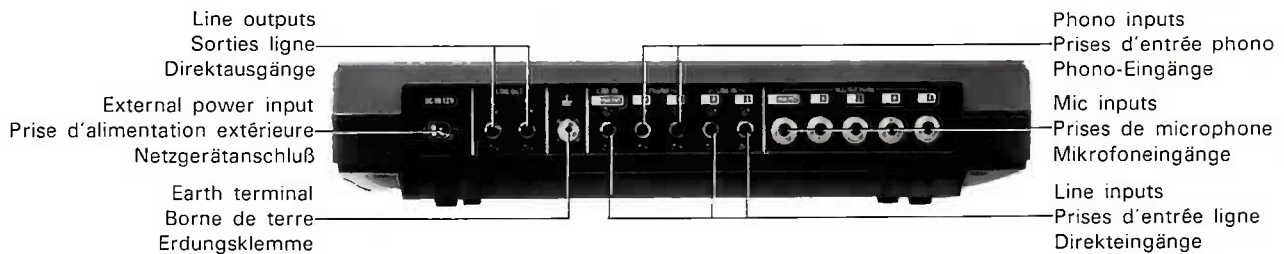

Réglage de potentiomètre panoramique [PAN POT]

Ce réglage permet de localiser la position acoustique des signaux d'entrée du canal 5 entre les deux canaux de sortie. La position centrale où un dé clic est ressenti, alimente les signaux à la position centrale des deux canaux aux niveaux équivalents. Cette position facilite le "mixage au centre" de la source sonore monophonique comme une narration ou un solo, fait entre les deux canaux.

Sélecteurs d'entrée [INPUT SELECT]

Choisir la position pour les signaux d'entrée branchés sur la prise correspondante.

LINE IN.....Pour les signaux d'entrée (tels que les signaux de tuner, de magnétophone, etc.) branchés sur les prises d'entrée ligne [LINE IN] (les canaux 1, 2 et 5).

PHONO.....Pour un tourne-disque connecté aux prises d'entrée phono [PHONO] (les canaux 3 et 4).

MIC.....Pour les microphones branchés sur les prises de microphone [MICROPHONE] (les canaux de 1 à 5).

ATT.....Cet avertissement est utile pour éviter la distorsion causée par une surcharge du préamplificateur de microphone lors de l'enregistrement des gros signaux d'entrée (musique de rock, musique moderne, etc.) ou avec un microphone placé trop près de la source sonore. (Avec cette position, le niveau de microphone est diminué de 20 dB.) Utiliser cette position lorsque les mètres dépassent le "0" plusieurs fois, avec le réglage de niveau d'entrée placé sur 3 ou inférieurs.

Index de repérage

Utiliser cet index comme un repérage de niveau normal, lorsque le niveau doit être changé temporairement.

„Pan Pot“-Regler (Panoramic Potentiometer) [PAN POT]

Diese Regler sind eine Art stufenlose Ausgangswähler und ermöglichen die akustische Platzierung des Kanal 5 Eingangssignals an jede beliebige Stelle zwischen den beiden Ausgängen. Bei eingeregelter Mittelstellung wird das Signal gleichermaßen dem linken und rechten Ausgangskanal zugeteilt. Dadurch wird das zentrale Mischen von Monoprogrammquellen wie Ansagen oder Instrumentensoli auf beide Kanäle erleichtert.

Eingangswähler [INPUT SELECT]

Damit werden die an den gleichen Eingangskanal angeschlossenen Eingänge geschaltet.

LINE IN.....Anschlüsse (z.B. Tuner, Tonbandgerät, usw.) an die Direkteingangsbuchsen [LINE IN] (Kanäle 1, 2 und 5).

PHONO.....An die Phonobuchsen [PHONO] angeschlossener Plattenspieler. (Kanäle 3 und 4).

MIC.....An die Mikrofonaufnahmen [MICROPHONE] angeschlossene Mikrofone. (Kanäle 1 bis 5).

ATT.....Durch diese Schaltung werden Verzerrungen durch Übersteuerung des Mikrofonverstärkers bei Eingangssignalen mit starken Pegelspitzen (z.B. Rock-Musik), oder wenn sich das Mikrofon zu nahe an der Schallquelle befindet, vermieden. (In dieser Schalterstellung wird der Mikrofoneingangspegel um 20 dB reduziert.) Benutzen Sie diese Schalterstellung, wenn die Pegelanzeige wiederholt über die „0“-Marke ausschlägt, obwohl sich der Eingangsregler unterhalb der „3“-Marke befindet.

Merkzeiger

Benutzen Sie diese Zeiger als Markpunkte, falls eine vorübergehende Verschiebung der eingestellten Pegel notwendig werden sollte.

Input level control

Adjusts either the mic or line, phono input level. Each control number corresponds to those of input (mic, or line/phono) channel. For example, to adjust channel 1 MIC input, set the INPUT SELECT switch to MIC, and adjust the control 1. Watch the meters as a guide. Slide all Input Level Controls not in use to "0" position in order to achieve the best S/N ratio possible.

Generally setting between 5 and 8 is recommended for better S/N, and low distortion results.

Level meters

Indicate the line output level. The "0" reading indicates the rated line output. The right meter also works as a Battery Check Meter with the BATT CHECK button depressed.

Battery check button [BATT CHECK]

To check battery condition, depress this button.

Power switch [POWER]

Turns the operating power on or off.

Headphone output [HEADPHONE]

Use a low impedance stereo headphone for monitoring.

Master level control [MASTER]

Once the various sources are properly mixed with each Input Level Control, adjust the overall output level with this control. The L and R output levels are adjusted simultaneously. This facilitates fade-in and fade-out effects.

Line outputs [LINE OUT]

Feed MX-510 line outputs to tape recorder or amplifier inputs.

External power inputs [DC IN 12 V]

Connect the Sony Power Adaptor AC-12 to this input.

Earth terminal []

When a record player or other connected audio equipment requires earth connection to reduce hum or other offensive noise, use this terminal.

Phono inputs (channels 3 and 4) [PHONO]

Accept outputs of record player. Magnetic phono cartridges are recommended. Crystal types are not recommended because of their high output level. Each PHONO input incorporates an equalizer circuitry.

MIC inputs (channels 1 to 5) [MICROPHONE]

Accept low impedance mics. Channel 5 has "pan-pot" effect.

Line inputs (channels 1, 2 and 5) [LINE IN]

Accept outputs of a tape recorder, tuner, amplifier. Channel 5 has "pan-pot" effect.

CONNECTION DIAGRAM

● When connecting a stereo source, it is recommended you make it a rule to connect its L-channel source to the odd-number input channel of the MX-510 and its R-channel source to the even-number input channel. This will simplify connection problems and make operation easier.

● Always keep in mind which input source corresponds to which input channel.

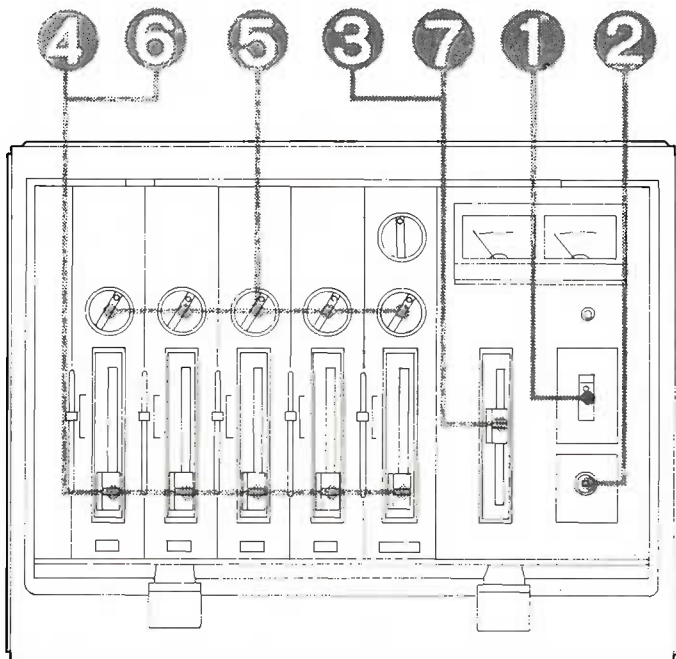
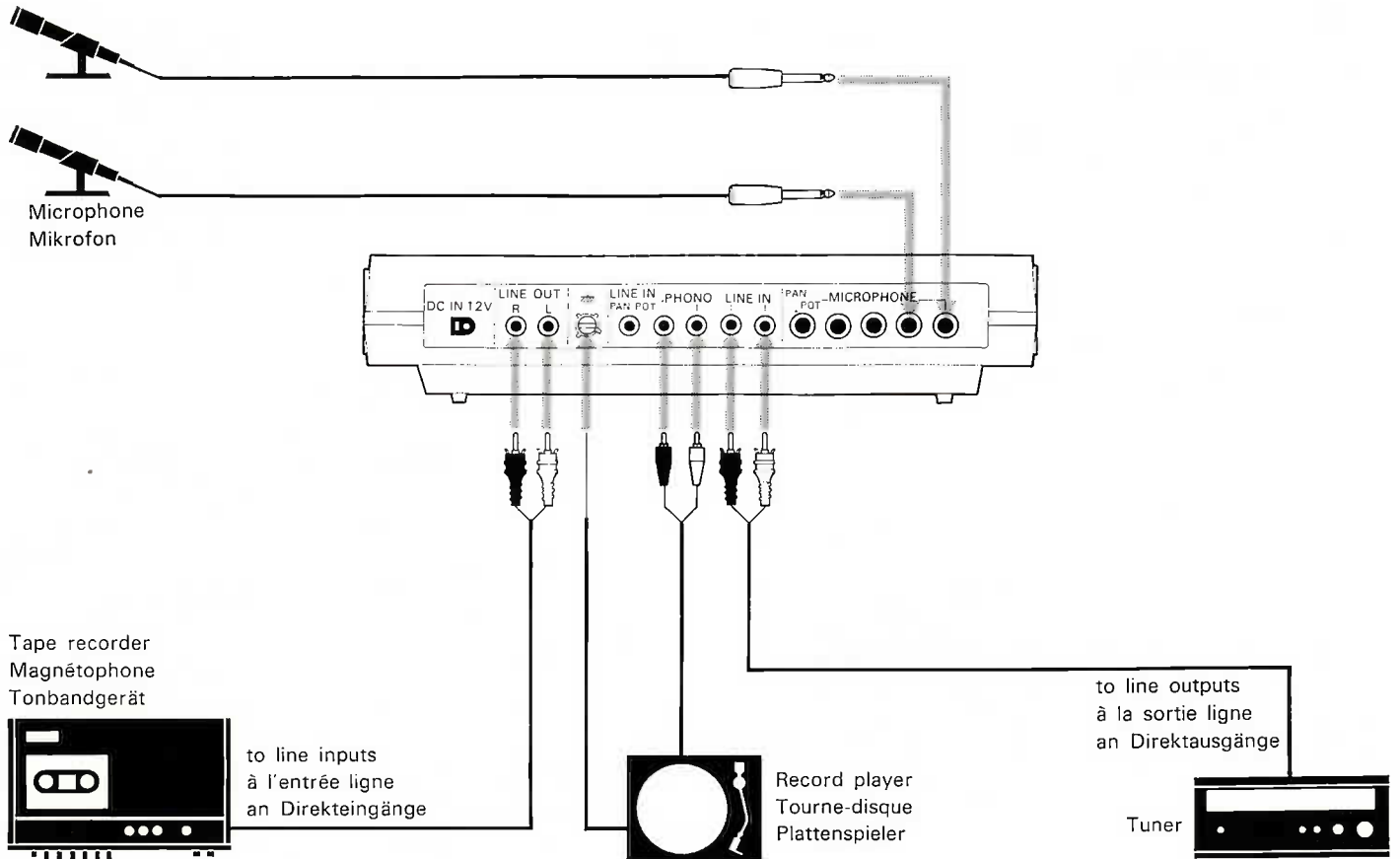

OPERATING PROCEDURE

1. Turn on the mixer and the tape recorder. Depress the BATT CHECK button for checking the battery condition.
2. Connect a headphone to the MX-510 HEADPHONE jack.
3. Set the MASTER control to slightly higher position.
4. Slide down each channel Input Level Control to "0" position.
5. Set each channel INPUT SELECT switch to the position to which the mixing source is connected.
6. While monitoring, adjust each channel level for the desired mixing balance. When using channel 5 input, adjust the PAN POT control. Be sure to keep the Level Controls not in use all the way down.
7. Adjust the MASTER control for overall level setting and fade-in/fade-out effects.

SPECIFICATIONS

Power Requirement	DC 12 V—size "C" battery (1.5 V) × 8 AC operation with the use of Sony Power Adaptor AC-12 (optional)	HEADPHONE (binaural type).....1 rated output level 49 mV (−24 dB) load impedance 8Ω
Power Consumption	0.4 W	Frequency Response 30 - 25,000 Hz
Battery Life	Approx. 60 hours of continuous operation (with Sony super size "C" batteries)	Distortion 0.5%
Inputs	MICROPHONE (phone type).....5 sensitivity 0.2 mV (−72 dB) low impedance LINE IN (phono type).....3 sensitivity 60 mV (−22 dB) input impedance 100 kΩ PHONO (phono type).....2 sensitivity 2.2 mV (−51 dB) input impedance 50 kΩ Including RIAA equalization network	Signal-to-Noise Ratio 60 dB
Outputs	LINE OUT (phono type).....2 rated output level 0.435 V (−5 dB) load impedance more than 10 kΩ	Dimensions Including projecting parts and controls. Approx. 348 (w) × 75 (h) × 240 (d) mm (13 3/4 × 3 × 9 1/2 inches)
		Weight approx. 3 kg (6 lb 10 oz) (with batteries included)
		Supplied Accessory Connecting Cord RK-74H (1)

● While the information given is true at the time of printing, small production changes in the course of our company's policy of improvement through research and design might not necessarily be indicated in the specifications. We would ask you to check with your appointed Sony dealer in clarification on any point is required.

SPECIFICATIONS

Alimentation	12 V CC avec huit piles format "C" (1,5 V) Alimentation sur le courant du secteur avec l'Adaptateur d'Alimentation Sony AC-12 (sur option)	Sorties	Sorties ligne [LINE OUT] (type coaxial)2 niveau de sortie évalué 0,435 V (−5 dB) impédance de charge plus de 10 kohms
Consommation	0,4 W	Prise de casque [HEADPHONE] (type à deux voies).....1 niveau de sortie évalué 49 mV (−24 dB) impédance de charge 8 ohms	
Durée des piles	Env. 60 heures d'utilisation continue (avec les Piles Super Sony format "C")	Réponse en fréquence 30 - 25 000 Hz	
Entrées	Prises de microphone [MICROPHONE] (type téléphonique).....5 sensibilité 0,2 mV (−72 dB) basse impédance Prises d'entrée ligne [LINE IN] (type coaxial)3 sensibilité 60 mV (−22 dB) impédance d'entrée 100 kohms Prises d'entrée phono [PHONO] (type coaxial)2 sensibilité 2,2 mV (−51 dB) impédance d'entrée 50 kohms y compris le circuit de correction RIAA	Distorsion 0,5%	
		Rapport signal sur bruit 60 dB	
		Dimensions hors tout Env. 348 (l) × 75 (h) × 240 (p) mm (13 3/4 × 3 × 9 1/2 pouces)	
		Poids Env. 3 kg (6 liv. 10 onces) (y compris les piles)	
		Accessoire fourni Cordon de Raccord RK-74H (1)	

● La conception et les caractéristiques peuvent être modifiées sans préavis.

TECHNISCHE DATEN

Spannungsversorgung	12 V Gleichspannung; 8 Babyzellen (1,5 V) Betrieb am Netz mit Sony Netzgerät AC-12 (auf Wunsch lieferbar)	Ausgänge	LINE OUT (Cinch-Buchsen)2 Nennausgangspegel 0,435 V (−5 dB) Belastungsimpedanz über 10 kOhm
Leistungsaufnahme	0,4 W	HEADPHONE (Stereo-Klinkenbuchse).....1 Nennausgangspegel 49 mV (−24 dB) Belastungsimpedanz 8 Ohm	
Batterielebensdauer	ca. 60 Stunden Dauerbetrieb (mit Sony Super Batterien, (Babyzellen))	Frequenzgang 30—25.000 Hz	
Eingänge	MICROPHONE (Klinkenbuchsen).....5 Eingangsempfindlichkeit 0,2 mV (−72 dB) Niederohmig LINE IN (Cinch-Buchsen).....3 Eingangsempfindlichkeit 60 mV (−22 dB) Eingangsimpedanz 100 kOhm PHONO (Cinch-Buchsen).....2 Eingangsempfindlichkeit 2,2 mV (−51 dB) Eingangsimpedanz 50 kOhm Einschließlich RIAA Entzerrerschaltung	Klirrgrad 0,5%	
		Signal-Rauschabstand 60 dB	
		Abmessungen einschließlich vorspringender Teile und Bedienungselemente 348 (B) × 75 (H) × 240 (T) mm	
		Gewicht ca. 3 kg (einschließlich Batterien)	
		Mitgeliefertes Zubehör Verbindungskabel RK-74H (1)	

● Änderungen, die dem technischen Fortschritt dienen, bleiben vorbehalten.