

Panasonic®

Operating Instructions

Digital Cordless Phone

Model No. **KX-TG6611FX**

KX-TG6612FX

Digital Cordless Answering System

Model No. **KX-TG6621FX**

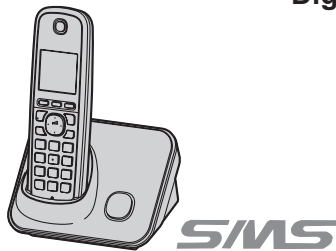

Model shown is KX-TG6611.

***Before initial use, see “Getting Started”
on page 10.***

Thank you for purchasing a Panasonic product.

Please read these operating instructions before using the unit and save them for future reference.

This unit is compatible with Caller ID and SMS. You must subscribe to the appropriate service offered by your service provider/telephone company.

To use this unit in your country, first change the unit's region setting to match your country (page 29). Change the unit's display language as needed (page 15).

(For Czech and Slovakia)

This cordless telephone is possible to use according to General licence No.: VO-R/8/08.2005-23 (for Czech), VPR-7/2001 (for Slovakia).

Table of Contents

Introduction	
Model composition	3
Accessory information	4
General information	5
Important Information	
For your safety	6
Important safety instructions	7
For best performance	7
Other information	8
Specifications	9
Getting Started	
Setting up	10
Note when setting up	11
Controls	12
Display	13
Turning the power on/off	15
Initial settings	15
One touch eco mode	16
Wall mounting	16
Making/Answering Calls	
Making calls	17
Answering calls	17
Useful features during a call	18
Key lock	19
Power back-up operation	19
Phonebook	
Handset phonebook	21
Copying phonebook entries	22
Programming	
Programmable settings	23
Special programming	27
Registering a unit	30
Caller ID Service	
Using Caller ID service	32
Caller list	32
SMS (Short Message Service)	
Using SMS	34
Turning SMS on/off	34
Storing SMS message centre numbers	34
Sending a message	34
Receiving a message	35
Other settings	36
Answering System	
Answering system	37
Turning the answering system on/off	37
Greeting message	
Listening to messages using the base unit	
Listening to messages using the handset	
Remote operation	
Answering system settings	
Voice Mail Service	
Voice mail service	
Intercom/Locator	
Intercom	
Handset locator	
Transferring calls, conference calls	
Useful Information	
Character entry	
Error messages	
Troubleshooting	
Index	
Index	

Introduction

Model composition

Series	Model No.	Base unit	Handset	
		Part No.	Part No.	Quantity
KX-TG6611 series	KX-TG6611	KX-TG6611	KX-TGA661	1
	KX-TG6612	KX-TG6611	KX-TGA661	2
KX-TG6621 series	KX-TG6621	KX-TG6621	KX-TGA661	1

- The suffix (FX) in the following model numbers will be omitted in these instructions:
KX-TG6611FX/KX-TG6612FX/KX-TG6621FX

Feature differences

Series	Answering system	Intercom
		Between handsets
KX-TG6611 series	–	●*1
KX-TG6621 series	●	●*1

*1 Single handset models: Intercom calls can be made between handsets by purchasing and registering one or more optional handsets (page 5).

Introduction

Accessory information

Supplied accessories

No.	Accessory item/Part number	Quantity	
		KX-TG6611 KX-TG6621	KX-TG6612
①	AC adaptor/PNLV226CE	1	2
②	Telephone line cord	1	1
③	Rechargeable batteries* ¹	2	4
④	Handset cover* ²	1	2
⑤	Charger	—	1

*1 See page 4 for replacement battery information.

*2 The handset cover comes attached to the handset.

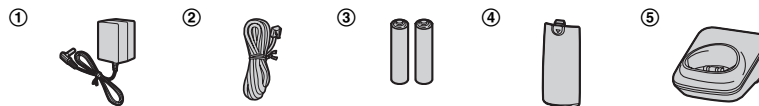

Additional/replacement accessories

Please contact your nearest Panasonic dealer for sales information.

Accessory item	Model number
Rechargeable batteries	HHR-4MRT or HHR-4NGE (P03P) or HHR-4MRE (P03I)* ¹
	Battery type: – Nickel metal hydride (Ni-MH) – 2 x AAA (R03) size for each handset
DECT repeater	KX-A405

*1 Replacement batteries may have a different capacity from that of the supplied batteries.

Introduction

Expanding your phone system

You can expand your phone system by registering optional handsets (6 max.) to a single base unit.

- Optional handsets may be a different colour from that of the supplied handsets.

Handset (optional): KX-TGA661FX



General information

- This equipment is designed for use on the Czech and Slovakia analogue telephone network.
- In the event of problems, you should contact your equipment supplier in the first instance.
- For use in other countries, please contact your equipment supplier.

Declaration of Conformity:

- Panasonic System Networks Co., Ltd. declares that this equipment is in compliance with the essential requirements and other relevant provisions of Radio & Telecommunications Terminal Equipment (R&TTE) Directive 1999/5/EC.

Declarations of Conformity for the relevant Panasonic products described in this manual are available for download by visiting:

<http://www.doc.panasonic.de>

Contact to Authorised Representative:

Panasonic Testing Centre
Panasonic Marketing Europe GmbH
Winsbergring 15, 22525 Hamburg, Germany

For your future reference

We recommend keeping a record of the following information to assist with any repair under warranty.

Serial No.

Date of purchase

(found on the bottom of the base unit)

Name and address of dealer

Attach your purchase receipt here.

Important Information

For your safety

To prevent severe injury and loss of life/property, read this section carefully before using the product to ensure proper and safe operation of your product.

WARNING

Power connection

- Use only the power source marked on the product.
- Do not overload power outlets and extension cords. This can result in the risk of fire or electric shock.
- Completely insert the AC adaptor/power plug into the power outlet. Failure to do so may cause electric shock and/or excessive heat resulting in a fire.
- Regularly remove any dust, etc. from the AC adaptor/power plug by pulling it from the power outlet, then wiping with a dry cloth. Accumulated dust may cause an insulation defect from moisture, etc. resulting in a fire.
- Unplug the product from power outlets if it emits smoke, an abnormal smell, or makes an unusual noise. These conditions can cause fire or electric shock. Confirm that smoke has stopped emitting and contact an authorised service centre.
- Unplug from power outlets and never touch the inside of the product if its casing has been broken open.
- Never touch the plug with wet hands. Danger of electric shock exists.

Installation

- To prevent the risk of fire or electrical shock, do not expose the product to rain or any type of moisture.
- Do not place or use this product near automatically controlled devices such as automatic doors and fire alarms. Radio waves emitted from this product may cause such devices to malfunction resulting in an accident.

- Do not allow the AC adaptor or telephone line cord to be excessively pulled, bent or placed under heavy objects.

Operating safeguards

- Unplug the product from power outlets before cleaning. Do not use liquid or aerosol cleaners.
- Do not disassemble the product.
- Do not spill liquids (detergents, cleansers, etc.) onto the telephone line cord plug, or allow it to become wet at all. This may cause a fire. If the telephone line cord plug becomes wet, immediately pull it from the telephone wall jack, and do not use.

Medical

- Consult the manufacturer of any personal medical devices, such as pacemakers or hearing aids, to determine if they are adequately shielded from external RF (radio frequency) energy. (The product operates in the frequency range of 1.88 GHz to 1.90 GHz, and the RF transmission power is 250 mW (max.)
- Do not use the product in health care facilities if any regulations posted in the area instruct you not to do so. Hospitals or health care facilities may be using equipment that could be sensitive to external RF energy.

CAUTION

Installation and location

- Never install telephone wiring during an electrical storm.
- Never install telephone line jacks in wet locations unless the jack is specifically designed for wet locations.
- Never touch uninsulated telephone wires or terminals unless the telephone line has been disconnected at the network interface.
- Use caution when installing or modifying telephone lines.
- The AC adaptor is used as the main disconnect device. Ensure that the AC outlet is installed near the product and is easily accessible.

Important Information

- This product is unable to make calls when:
 - the handset batteries need recharging or have failed.
 - there is a power failure.
 - the key lock feature is turned on.
- 3. Do not use the telephone to report a gas leak in the vicinity of the leak.
- 4. Use only the power cord and batteries indicated in this manual. Do not dispose of batteries in a fire. They may explode. Check with local codes for possible special disposal instructions.

SAVE THESE INSTRUCTIONS

For best performance

Base unit location/avoiding noise

The base unit and other compatible Panasonic units use radio waves to communicate with each other.

- For maximum coverage and noise-free communications, place your base unit:
 - at a convenient, high, and central location with no obstructions between the handset and base unit in an indoor environment.
 - away from electronic appliances such as TVs, radios, personal computers, wireless devices, or other phones.
 - facing away from radio frequency transmitters, such as external antennas of mobile phone cell stations. (Avoid putting the base unit on a bay window or near a window.)
- Coverage and voice quality depends on the local environmental conditions.
- If the reception for a base unit location is not satisfactory, move the base unit to another location for better reception.

Environment

- Keep the product away from electrical noise generating devices, such as fluorescent lamps and motors.
- The product should be kept free from excessive smoke, dust, high temperature, and vibration.
- The product should not be exposed to direct sunlight.
- Do not place heavy objects on top of the product.

Battery

- We recommend using the batteries noted on page 4. **USE ONLY rechargeable Ni-MH batteries AAA (R03) size.**
- Do not mix old and new batteries.
- Do not open or mutilate the batteries. Released electrolyte from the batteries is corrosive and may cause burns or injury to the eyes or skin. The electrolyte is toxic and may be harmful if swallowed.
- Exercise care when handling the batteries. Do not allow conductive materials such as rings, bracelets, or keys to touch the batteries, otherwise a short circuit may cause the batteries and/or the conductive material to overheat and cause burns.
- Charge the batteries provided with or identified for use with this product only, in accordance with the instructions and limitations specified in this manual.
- Only use a compatible base unit (or charger) to charge the batteries. Do not tamper with the base unit (or charger). Failure to follow these instructions may cause the batteries to swell or explode.

Important safety instructions

When using your product, basic safety precautions should always be followed to reduce the risk of fire, electric shock, and injury to persons, including the following:

1. Do not use this product near water for example, near a bathtub, washbowl, kitchen sink, or laundry tub, in a wet basement or near a swimming pool.
2. Avoid using a telephone (other than a cordless type) during an electrical storm. There may be a remote risk of electric shock from lightning.

Important Information

- When you leave the product unused for a long period of time, unplug the product from the power outlet.
- The product should be kept away from heat sources such as radiators, cookers, etc. It should not be placed in rooms where the temperature is less than 0 °C or greater than 40 °C. Damp basements should also be avoided.
- The maximum calling distance may be shortened when the product is used in the following places: Near obstacles such as hills, tunnels, underground, near metal objects such as wire fences, etc.
- Operating the product near electrical appliances may cause interference. Move away from the electrical appliances.

Routine care

- **Wipe the outer surface of the product with a soft moist cloth.**
- Do not use benzine, thinner, or any abrasive powder.

Other information

Notice for product disposal, transfer, or return

- This product can store your private/confidential information. To protect your privacy/confidentiality, we recommend that you erase information such as phonebook or caller list entries from the memory before you dispose of, transfer, or return the product.

Information for Users on Collection and Disposal of Old Equipment and used Batteries

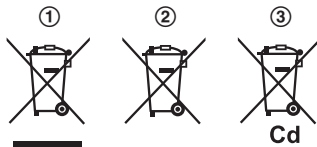

These symbols (①, ②, ③) on the products, packaging, and/or accompanying documents mean that used electrical and electronic products and batteries should not be mixed with general household waste.

For proper treatment, recovery and recycling of old products and used batteries, please take them to applicable collection points, in accordance with your national legislation and the Directives 2002/96/EC and 2006/66/EC. By disposing of these products and batteries correctly, you will help to save valuable resources and prevent any potential negative effects on human health and the environment which could otherwise arise from inappropriate waste handling.

For more information about collection and recycling of old products and batteries, please contact your local municipality, your waste disposal service or the point of sale where you purchased the items.

Penalties may be applicable for incorrect disposal of this waste, in accordance with national legislation.

For business users in the European Union

If you wish to discard electrical and electronic equipment, please contact your dealer or supplier for further information.

Information on Disposal in other Countries outside the European Union

These symbols (①, ②, ③) are only valid in the European Union. If you wish to discard these items, please contact your local authorities or dealer and ask for the correct method of disposal.

Note for the battery symbol

This symbol (②) might be used in combination with a chemical symbol (③). In this case it complies with the requirement set by the Directive for the chemical involved.

Important Information

Specifications

- **Standard:**
DECT (Digital Enhanced Cordless Telecommunications),
GAP (Generic Access Profile)
 - **Frequency range:**
1.88 GHz to 1.90 GHz
 - **RF transmission power:**
Approx. 10 mW (average power per channel)
 - **Power source:**
220–240 V AC, 50/60 Hz
 - **Power consumption:**
Base unit^{*1}:
Standby: Approx. 0.4 W
Maximum: Approx. 2.3 W
Base unit^{*2}:
Standby: Approx. 0.5 W
Maximum: Approx. 2.4 W
Charger:
Standby: Approx. 0.1 W
Maximum: Approx. 1.8 W
 - **Operating conditions:**
0 °C – 40 °C, 20 % – 80 % relative air humidity (dry)
- *1 KX-TG6611/KX-TG6612
*2 KX-TG6621
- Note:**
- Design and specifications are subject to change without notice.
 - The illustrations in these instructions may vary slightly from the actual product.

Getting Started

Setting up

Connections

- Use only the supplied Panasonic AC adaptor PNLV226CE.
- When mounting the unit on a wall, see page 16.

■ Base unit (KX-TG6611/KX-TG6612)

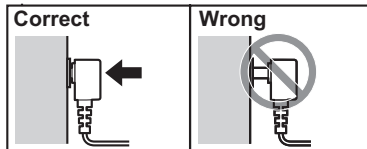
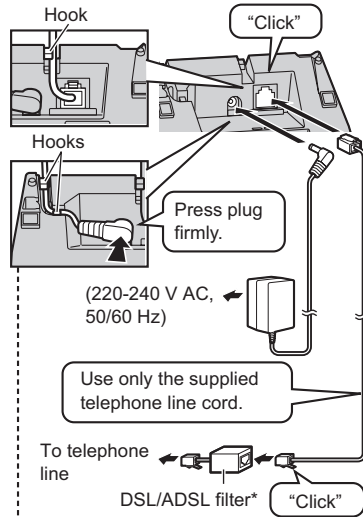

*DSL/ADSL filter (not supplied) is required if you have DSL/ADSL service.

■ Base unit (KX-TG6621)

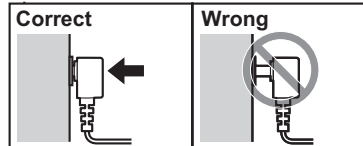
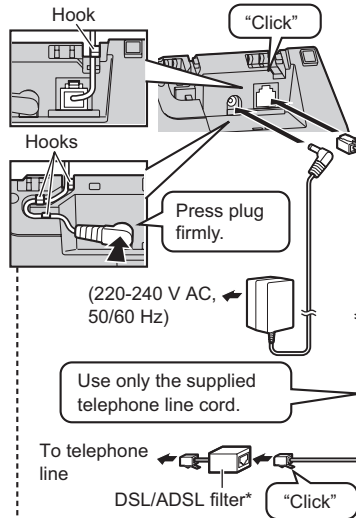

*DSL/ADSL filter (not supplied) is required if you have DSL/ADSL service.

■ Charger

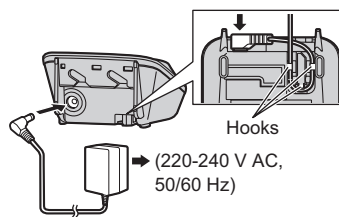

Getting Started

Battery installation

- USE ONLY Ni-MH batteries AAA (R03) size.
- Do NOT use Alkaline/Manganese/Ni-Cd batteries.
- Confirm correct polarities (+, -).

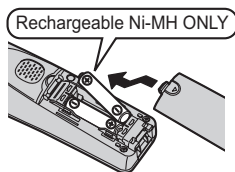
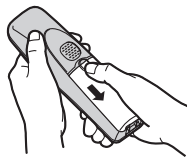

- When the language selection is displayed, see page 15.

Battery charging

Charge for about 7 hours.

- When the batteries are fully charged, the charge indicator goes off and "Fully charged" is displayed.

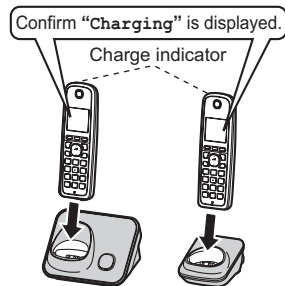

Note when setting up

Note for connections

- The AC adaptor must remain connected at all times. (It is normal for the adaptor to feel warm during use.)
- The AC adaptor should be connected to a vertically oriented or floor-mounted AC outlet. Do not connect the AC adaptor to a ceiling-mounted AC outlet, as the weight of the adaptor may cause it to become disconnected.

Note for battery installation

- Use the supplied rechargeable batteries. For replacement, we recommend using the Panasonic rechargeable batteries noted on page 4, 7.
- Wipe the battery ends (+, -) with a dry cloth.
- Avoid touching the battery ends (+, -) or the unit contacts.

Note for battery charging

- It is normal for the handset to feel warm during charging.
- Clean the charge contacts of the handset, base unit, and charger with a soft and dry cloth once a month. Before cleaning the unit, disconnect from power outlets and any telephone line cords. Clean more often if the unit is exposed to grease, dust, or high humidity.

Battery level

Icon	Battery level
	High
	Medium
	Low
	Needs charging.

Getting Started

Panasonic Ni-MH battery performance (supplied batteries)

Operation	Operating time
In continuous use	15 hours max.
Not in use (standby)	170 hours max.

Note:

- It is normal for batteries not to reach full capacity at the initial charge. Maximum battery performance is reached after a few complete cycles of charge/discharge (use).
- Actual battery performance depends on usage and ambient environment.
- Even after the batteries are fully charged, the handset can be left on the base unit or charger without any ill effect on the batteries.
- The battery level may not be displayed correctly after you replace the batteries. In this case, place the handset on the base unit or charger and let it charge for at least 7 hours.

Controls

Base unit

■ KX-TG6611/KX-TG6612

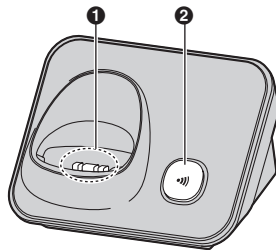

- 1 Charge contacts
- 2 [•••] (Locator)

■ KX-TG6621

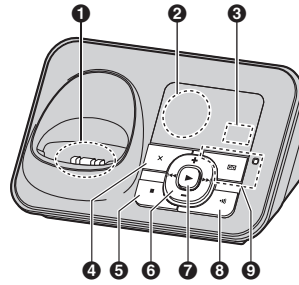

- 1 Charge contacts
- 2 Speaker
- 3 Message counter
- 4 [X] (Erase)
- 5 [■] (Stop)
- 6 [+]/[-] (Volume up/down)
- [◀]/[▶] (Repeat/Skip)
- 7 [▶] (Play)
- Message indicator
- 8 [•••] (Locator)
- 9 [☎] (Answer on)
- Answer on indicator

Getting Started

Handset

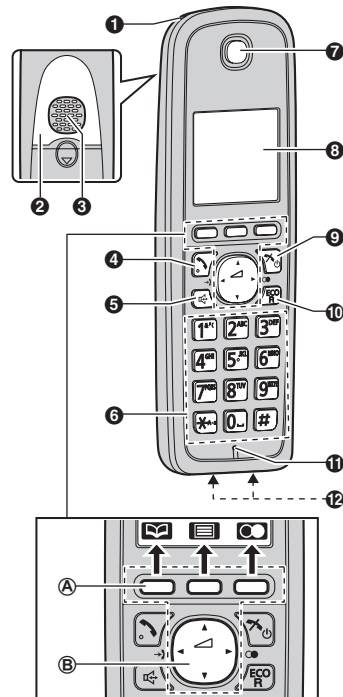

- 1 Charge indicator
Ringer indicator**
- 2 Secure grip**
 - Secure grip offers support when you cradle the handset between your shoulder and ear.
- 3 Speaker**
- 4 [↶] (Talk)**
- 5 [☎] (Speakerphone)**
- 6 Dial keypad**
- 7 Receiver**
- 8 Display**
- 9 [⏻] (Off/Power)**

- 10 [ECO/R]**
ECO: Eco mode shortcut key
R: Recall/Flash
- 11 Microphone**
- 12 Charge contacts**
- **Control type**
 - Ⓐ **Soft keys**
The handset features 3 soft keys. By pressing a soft key, you can select the feature shown directly above it on the display.
 - Ⓑ **Navigator key**
 - [▲], [▼], [←], or [→]: Scroll through various lists and items.
 - [⏮] (Volume: [▲] or [▼]): Adjust the receiver or speaker volume while talking.
 - [←] (☎): Caller list: View the caller list.
 - [→] (☎): Redial: View the redial list.

Display

Handset display items

Item	Meaning
	Range status: The more bars visible, the closer the handset is to the base unit.
	Out of base unit range
	Paging, intercom mode.
	Speakerphone is on. (page 17)
	The line is in use. <ul style="list-style-type: none"> • When flashing slowly: The call is put on hold. • When flashing rapidly: An incoming call is now being received.
	Missed call ¹ (page 32)
	The base unit transmission power is set to "Low". (page 16)
	The LCD and key backlight is off. (page 25)

Getting Started

Item	Meaning
	<ul style="list-style-type: none"> When displayed next to the battery icon: Answering system is on.^{*2} (page 37) When displayed with a number: New messages have been recorded.^{*2} (page 39)
	Answering system answers calls with a greeting message and caller messages are not recorded. ^{*2} ("Selecting Greeting Only ", page 41)
	Battery level
	Alarm is on. (page 27)
	Equalizer is set. (page 18)
	Privacy mode is on. (page 26)
	Ringer volume is off. (page 25)
	Night mode is on. (page 28)
	Blocked call ^{*1} (page 28, 32)
	New SMS message received. ^{*3} (page 35)
	New voice mail message received. ^{*4} (page 42)
Line in use	Someone is using the line.
IN USE	Answering system is being used by another handset or the base unit. ^{*2}

*1 Caller ID subscribers only
 *2 KX-TG6621
 *3 SMS users only
 *4 Voice mail subscribers only

Base unit display items

■ KX-TG6621

Item	Meaning
--	Answering system answers calls with a greeting message and caller messages are not recorded. ("Selecting Greeting Only ", page 41)

Handset soft key icons

Icon	Action
	Returns to the previous screen or outside call.
	Displays the menu.
	Accepts the current selection.
	Displays a previously dialed phone number.
	Makes a call. (page 17)
	Temporarily turns off the ringer for incoming calls. (page 17)
	Sets 24-hour or 12-hour clock format. (page 15)
	Places a call on hold.
	Opens the phonebook.
	Allows you to edit phone numbers. (page 28, 32)
	Adds new entry. (page 21, 28)
	Displays the character entry mode for phonebook search. (page 21)
	Turns the key lock feature off. (page 19)
	Selects a character entry mode.
	Selects handsets. (page 29)
	Stops recording or playback. ^{*1}
	Stores phone numbers. (page 28, 33)
	Inserts a dialling pause.

Getting Started

Icon	Action
	Erases the selected item or returns to the outside call.
	Allows you to make an intercom call. (page 43)
	Erases a number/character.
	Puts the call on mute.

*1 KX-TG6621

Turning the power on/off

Power on

Press **[Mute]** for about 1 second.

Power off

Press **[Mute]** for about 2 seconds.

Initial settings

■ Direct command code:

Programmable settings can be accessed by pressing **[Menu]**, **[#]** and then the corresponding code on the dial keypad (page 23).

Example: Press **[Menu] [#] 1 0 1**.

■ Symbol meaning:

Example: **[Up/Down]**: "Off"

Press **[V]** or **[A]** to select the words in quotations.

Important:

- When you install the batteries for the first time, the handset may prompt you to set display language and region setting.
 - Perform step 2 in "Display language", page 15, and then press **OK**.
 - Continue from step 2 in "Changing the unit's region setting/Resetting the base unit", page 29.

Display language

16 display languages are available.

You can select "Deutsch", "English", "Magyar", "Polski", "Slovenčina", "Čeština", "Hrvatski", "Slovenščina", "Besti", "Lietuviškai", "Latviešu", "Română", "Български", "Srpski", "Македонски", or "Shqip".

- [Menu] [#] 1 1 0**
- [Up/Down]**: Select your desired language. → **OK**
- [Mute]**

Date and time

- [Menu] [#] 1 0 1**
- Enter the current date, month, and year. → **OK**
Example: 15 July, 2011
1 5 0 7 1 1
- Enter the current hour and minute.
Example: 9:30
0 9 3 0
 - You can select 24-hour or 12-hour clock format ("AM" or "PM") by pressing **12/24**.
- OK** → **[Mute]**

Note:

- The date and time may be incorrect after a power failure. In this case, set the date and time again.

Dialling mode

If you cannot make calls, change this setting according to your telephone line service. The default setting is "Tone".

"Tone": For tone dial service.

"Pulse": For rotary/pulse dial service.

- [Menu] [#] 1 2 0**
- [Up/Down]**: Select the desired setting.
- OK** → **[Mute]**

Getting Started

One touch eco mode

When the handset is on the base unit, the base unit transmission power is reduced up to 99.9% if only one handset is registered. Even when the handset is not on the base unit or several handsets are registered, the base unit transmission power in standby mode can be reduced up to 90% by activating one touch eco mode.

You can turn on/off one touch eco mode by just pressing **[ECO/R]**. The default setting is "Normal".

- When the one touch eco mode is on: "Low" is temporarily displayed and **ECO** is shown on the handset display instead of **Y**.
- When the one touch eco mode is off: "Normal" is temporarily displayed and **ECO** goes off from the handset display.

Note:

- When there is another cordless phone nearby and it is in use, the base unit transmission power may not be reduced.
- Activating one touch eco mode reduces the range of the base unit in standby mode.
- If you set the repeater mode to "On" (page 31):
 - One touch eco mode is cancelled.
 - "Eco Setup" is not shown in the display menu (page 25).

Wall mounting

Note:

- Make sure that the wall and the fixing method are strong enough to support the weight of the unit.

■ Base unit (KX-TG6611/KX-TG6612)

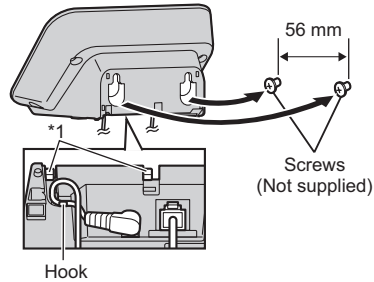

■ Base unit (KX-TG6621)

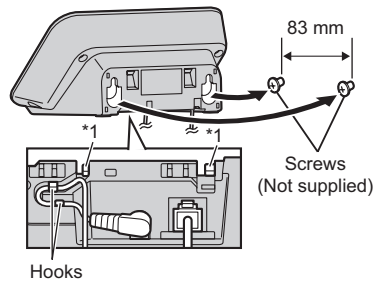

*1 When mounting the base unit on a wall, do not pass the cords through these hooks.

■ Charger

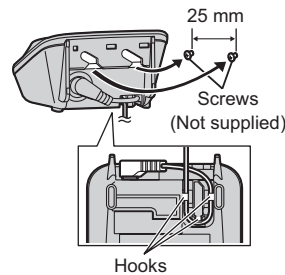

Making/Answering Calls

Making calls

- 1 Lift the handset and dial the phone number.
 - To correct a digit, press **C**.
- 2 Press **[↶]** or **[↷]**.
- 3 When you finish talking, press **[⏏]** or place the handset on the base unit or charger.

Using the speakerphone

- 1 Dial the phone number and press **[☎]**.
 - Speak alternately with the other party.
- 2 When you finish talking, press **[⏏]**.

Note:

- For best performance, use the speakerphone in a quiet environment.
- To switch back to the receiver, press **[☎]/[↶]**.

Adjusting the receiver or speaker volume

Press **[▲]** or **[▼]** repeatedly while talking.

Making a call using the redial list

The last 10 phone numbers dialed are stored in the redial list (each 24 digits max.).

- 1 **[☎]** or **[▶]** (**[☎]**)
- 2 **[↕]**: Select the desired phone number.
- 3 **[↶]**

Erasing a number in the redial list

- 1 **[☎]** or **[▶]** (**[☎]**)
- 2 **[↕]**: Select the desired phone number.
→ **[X]**
- 3 **[↕]**: "Yes" → **[OK]** → **[⏏]**

Pause (for PBX/long distance service users)

A pause is sometimes required when making calls using a PBX or long distance service. When storing a calling card access number and/or PIN in the phonebook, a pause is also needed (page 21).

Example: If you need to dial the line access number "0" when making outside calls with a PBX:

- 1 **[0]** → **[P]**
- 2 Dial the phone number. → **[↶]**

Note:

- A 3 second pause is inserted each time **[P]** is pressed. Repeat as needed to create longer pauses.

Answering calls

When a call is being received, the ringer indicator flashes rapidly.

- 1 Lift the handset and press **[↶]** or **[☎]** when the unit rings.
 - You can also answer the call by pressing any dial key from **[0]** to **[9]**, **[*]**, or **[#]**. (**Any key answer feature**)
- 2 When you finish talking, press **[⏏]** or place the handset on the base unit or charger.

Auto talk

You can answer calls simply by lifting the handset off the base unit or charger. You do not need to press **[↶]**. To turn this feature on, see page 25.

Adjusting the handset ringer volume

- **While the handset is ringing for an incoming call:**
Press **[▲]** or **[▼]** repeatedly to select the desired volume.
- **Programming the volume beforehand:**
 - 1 **[☎]** **[#]** **[1]** **[6]** **[0]**
 - 2 **[↕]**: Select the desired volume.
 - 3 **[OK]** → **[⏏]**

Temporary handset ringer off



While the handset is ringing for a call, you can turn the ringer off temporarily by pressing **[Z]**.

Making/Answering Calls

Useful features during a call

Hold

This feature allows you to put an outside call on hold.



- 1 Press  during an outside call.
- 2 [\uparrow]: "Hold" → **OK**
- 3 To release hold, press .
 - Another handset user can take the call by pressing .

Note:

- If a call is kept on hold for more than 9 minutes, an alarm tone starts to sound and the ringer indicator flashes rapidly. After 1 additional minute on hold, the call is disconnected.
- If another phone is connected to the same line, you can also take the call by lifting its handset.

Mute

While mute is turned on, you can hear the other party, but the other party cannot hear you.

- 1 Press  during conversation.
 -  flashes.
- 2 To return to the conversation, press  again.

Recall/flash

[ECO/R] allows you to use the special features of your host PBX such as transferring an extension call, or accessing optional telephone services.

Note:

- To change the recall/flash time, see page 26.

For call waiting or Call Waiting Caller ID service users

To use call waiting or Call Waiting Caller ID, you must first subscribe with your service provider/telephone company.

This feature allows you to receive calls while you are already talking on the phone. If you receive a call while on the phone, you will hear a call waiting tone.

If you subscribe to both Caller ID and Call Waiting with Caller ID services, the 2nd caller's information is displayed after you hear the call waiting tone on the handset.

- 1 Press **[ECO/R]** to answer the 2nd call.
- 2 To switch between calls, press **[ECO/R]**.

Note:

- Please contact your service provider/telephone company for details and availability of this service in your area.

Temporary tone dialling (for rotary/pulse service users)

You can temporarily switch the dialling mode to tone when you need to access touch-tone services (for example, answering services, telephone banking services, etc.). Press  before entering access numbers which require tone dialling.

Handset equalizer

This feature clarifies the voice of the person you are talking to, producing a more natural-sounding voice that is easier to hear and understand.

- 1 Press  while talking.
- 2 [\uparrow]: "Equalizer" → **OK**
- 3 [\uparrow]: Select the desired setting.
- 4 Press **OK** to exit.

Note:

- When this feature is turned on, E^{H} is displayed while talking.
- Depending on the condition and quality of your telephone line, this feature may emphasise existing line noise. If it becomes difficult to hear, turn this feature off.
- This feature is not available while using the speakerphone.

Making/Answering Calls

Call share

You can join an existing outside call. To join the conversation, press **[📞]** when the other handset is on an outside call.

Note:

- To prevent other users from joining your conversations with outside callers, turn the privacy mode on (page 26).

Key lock

The handset can be locked so that no calls or settings can be made. Incoming calls can be answered, but all other functions are disabled while key lock is on.

To turn key lock on, press **[🔒]** for about 3 seconds.

- **[🔒]** is displayed.
- To turn key lock off, press **[🔒]** for about 3 seconds.

Note:

- Calls to emergency numbers cannot be made until key lock is turned off.

Power back-up operation

When a power failure occurs, the charged handset temporarily supplies power to the base unit (power back-up mode). This allows you to make and receive calls using a handset during a power failure. The base unit will not perform any other functions. You can program "Power Failure" and the default setting is "Auto" (page 26).

Important:

- If a handset is not placed on the base unit when a power failure occurs, "Base no power Press **[📞]**" is displayed. After pressing **[📞]** on the handset, place it on the base unit to start power back-up mode.
- Power back-up mode will not work if the battery level of the power supplying handset is **[🔋]** or **[🔋]**.
- Do not lift the power supplying handset from the base unit during power back-up mode.

- Do not touch the handset's charge contacts during power back-up mode.
- If the battery level is low, the unit will not work sufficiently during power back-up mode. In addition, in case handset battery power runs out, we recommend connecting a corded-type telephone (without AC adaptor) to the same telephone line or to the same telephone line jack, if you have such a telephone jack in your house.
- Calls cannot be made during a power failure until key lock is turned off (page 19).

Panasonic Ni-MH battery performance (supplied batteries) during power back-up mode

When the batteries are fully charged, operating time of the handset in power back-up mode varies depending on usage.

- Continuous use of the handset in power back-up mode: 2 hours max.
- Continuous use of the handset other than a handset in power back-up mode: 3 hours max.
- Not in use in power back-up mode: 3 hours max.

Note:

- Actual battery performance depends on usage and ambient environment.

Making calls during a power failure

■ When only 1 handset is registered:

- 1 Lift the handset and dial the phone number.
- 2 Within 1 minute, place the handset on the base unit.
 - Wait until speakerphone is turned on automatically and the call is made.
- 3 When the other party answers the call, keep the handset on the base unit and talk using the speakerphone.
- 4 When you finish talking, press **[📞]**.

Note:

- In step 2, if you do not place the handset on the base unit within 1 minute, the power

Making/Answering Calls

back-up mode turns off. In this case, press **[*☎]** on the handset and dial the phone number. Then try again from step 2.

- **When 2 or more handsets are registered:** You should leave one handset on the base unit for supplying the power, and use another handset for making calls. For the operation, please see "Making calls", page 17.

Note:

- During a call with the handset placed on the base unit (power back-up mode), the call may be disconnected if you touch the handset. In such case, try to call back.
- The range of the base unit is limited during a power failure. Please use the handset close to the base unit.

Making a call using the redial list

- **When only 1 handset is registered:**
 - 1 Lift the handset.
 - 2 **[☎]** or **[▶] (☎)**
 - 3 **[*]:** Select the desired phone number.
 - 4 Within 1 minute, place the handset on the base unit.
 - Wait until speakerphone is turned on automatically and the call is made.
- **When 2 or more handsets are registered:** You should leave one handset on the base unit for supplying the power, and use another handset for making calls. For the operation, please see "Making a call using the redial list", page 17.

Making a call using the handset phonebook

- **When only 1 handset is registered:**
 - 1 Lift the handset.
 - 2 **[☎]**
 - 3 **[*]:** Select the desired entry.
 - 4 Within 1 minute, place the handset on the base unit.
 - Wait until speakerphone is turned on automatically and the call is made.

- **When 2 or more handsets are registered:** You should leave one handset on the base unit for supplying the power, and use another handset for making calls. For the operation, please see "Finding and calling from a phonebook entry", page 21.

Answering calls during a power failure

- **When only 1 handset is registered:**
 - 1 When the unit rings, keep the handset on the base unit and press **[☎]** or **[☎]**.
 - Speakerphone is turned on.
 - 2 When you finish talking, press **[*☎]**.
- **When 2 or more handsets are registered:** When the unit rings, use a handset which is not supplying power to the base unit. For the operation, please see "Answering calls", page 17.
 - Do not use or lift the handset which is placed on the base unit during power back-up mode.

Note:

- During a call with the handset placed on the base unit (power back-up mode), the call may be disconnected if you touch the handset. In such case, try to call back.
- The range of the base unit is limited during a power failure. Please use the handset close to the base unit.

Phonebook

Handset phonebook

The phonebook allows you to make calls without having to dial manually. You can add 100 names and phone numbers.

Adding entries

- 1 →
- 2 Enter the party's name (16 characters max.). → **OK**
 - You can change the character entry mode by pressing **11A/?** (page 44).
- 3 Enter the party's phone number (24 digits max.). → **OK** 2 times
 - To add other entries, repeat from step 2.
- 4

Finding and calling from a phonebook entry

Scrolling through all entries

- 1
- 2 : Select the desired entry.
 - You can scroll through the phonebook entry by pressing and holding **[v]** or **[^]**.
- 3

Searching by first character

- 1
 - Change the character entry mode if necessary:
 - : Select the character entry mode. → **OK**
- 2 Press the dial key (**[0]** to **[9]**, or **[#]**) which contains the character you are searching for (page 44).
 - Press the same dial key repeatedly to display the first entry corresponding to each character located on that dial key.

- If there is no entry corresponding to the character you selected, the next entry is displayed.

- 3 : Scroll through the phonebook if necessary.
- 4

Editing entries

- 1 Find the desired entry (page 21). →
- 2 : "Edit" → **OK**
- 3 Edit the name if necessary (16 characters max.; page 44). → **OK**
- 4 Edit the phone number if necessary (24 digits max.). → **OK** 2 times →

Erasing entries

Erasing an entry

- 1 Find the desired entry (page 21).
- 2 **X** → : "Yes" → **OK** →

Erasing all entries

- 1 →
- 2 : "Erase All" → **OK**
- 3 : "Yes" → **OK**
- 4 : "Yes" → **OK** →

Chain dial

This feature allows you to dial phone numbers in the phonebook while you are on a call. This feature can be used, for example, to dial a calling card access number or bank account PIN that you have stored in the phonebook, without having to dial manually.



- 1 During an outside call, press .
- 2 : "Phonebook" → **OK**
- 3 : Select the desired entry.
- 4 Press to dial the number.

Note:

- When storing a calling card access number and your PIN in the phonebook as one phonebook entry, press **P** to add pauses

Phonebook

after the number and PIN as necessary (page 17).







- If you have rotary/pulse service, you need to press  before pressing  in step 1 to change the dialling mode temporarily to tone. When adding entries to the phonebook, we recommend adding  to the beginning of phone numbers you wish to chain dial (page 21).

Copying phonebook entries





You can copy phonebook entries between 2 handsets.*1

*1 Panasonic compatible handset

Copying an entry

- 1 Find the desired entry (page 21). → 
- 2 []: "Copy" → **OK**
- 3 []: Select the handset you want to send the phonebook entry to. → **OK**
 - When an entry has been copied, "Completed" is displayed.
 - To continue copying another entry:
[]: "Yes" → **OK** → []: Select the desired entry. → **OK**
- 4 [

Copying all entries

- 1  → 
- 2 []: "Copy All" → **OK**
- 3 []: Select the handset you want to send the phonebook entry to. → **OK**
 - When all entries have been copied, "Completed" is displayed.
- 4 [

Programming



Programmable settings

You can customise the unit by programming the following features using the handset. To access the features, there are 2 methods.

■ Scrolling through the display menus

- 1 
- 2 Press [▼] or [▲] to select the desired main menu. → **OK**
- 3 Press [▼] or [▲] to select the desired item from the next sub-menus. → **OK**
- 4 Press [▼] or [▲] to select the desired setting. → **OK**
 - This step may vary depending on the feature being programmed.
 - To exit the operation, press [**⏏**].

■ Using the direct command code

- 1  → Enter the desired code.
Example: Press  **#1101**.
- 2 Select the desired setting. → **OK**
 - This step may vary depending on the feature being programmed.
 - To exit the operation, press [**⏏**].

Note:

- In the following table, < > indicates the default settings.
- In the following table,  indicates the reference page number.
- Display menu order and sub-menu may vary depending on your model.

Display the menu tree and direct command code table

Main menu:  "Caller List"

Operation	Code	
Viewing the caller list.	#213	32

Main menu:  "Answer System"^{*1}

Sub-menu 1	Sub-menu 2	Settings	Code	
Play New Msg.	–	–	#323	39
Play All Msg.	–	–	#324	39
Erase All Msg. ^{*2}	–	–	#325	39
Greeting	Start REC ^{*2} (Record greeting)	–	#302	38
	Play Greeting	–	#303	38
	Default ^{*2} (Reset to pre-recorded greeting)	–	#304	38

Programming

Sub-menu 1	Sub-menu 2	Settings	Code	
Settings	Number of Rings ^{*2}	2-6: 2-6 Rings 4: <4 Rings> 0: Auto	#211	40
	Recording Time ^{*2}	1: 1 Minute 3: <3 Minutes> 0: Greeting Only ^{*3}	#305	41
	Remote Code ^{*2}	-	#306	39
	Call Screening	1: <On> 0: Off	#310	37
Answer On ^{*2}	-	-	#327	37
Answer Off ^{*2}	-	-	#328	37

Main menu:  "SMS"

Sub-menu 1	Sub-menu 2	Settings	Code	
Receive List	-	-	#350	35
Send List	-	-		35
Create	-	-		34
Settings	Message Centre1 ^{*2, *4}	-	#351	34
	Message Centre2 ^{*2, *4}	-	#352	34
	PBX Access # ^{*2}	<Off>	#356	36
	SMS On/Off ^{*2, *5}	<Off>	#357	34

Main menu:  "Intercom"

Operation	Code	
Paging the desired unit.	#274	43

Main menu:  "Time Settings"

Sub-menu 1	Sub-menu 2	Settings	Code	
Set Date/Time ^{*2}	-	-	#101	15
Alarm	-	1: Once 2: Daily 0: <Off>	#720	27
Time Adjustment ^{*2, *6}	-	1: Caller ID 0: <Manual>	#226	-

Main menu:  "Ringer Setup"^{*7}

Sub-menu 1	Sub-menu 2	Settings	Code	
Ringer Volume ^{*8} (Handset)	-	0-6: Off-6 <6>	#160	17
Ringtone ^{*9, *10} (Handset)	-	<Ringtone 1>	#161	-

Programming

Sub-menu 1	Sub-menu 2	Settings	Code	
Night Mode	On/Off	1: On 0: <Off>	#238	27
	Start/End	<23:00/06:00>	#237	28
	Ring Delay	1: 30 sec. 2: <60 sec.> 3: 90 sec. 4: 120 sec. 0: No Ringing	#239	28

Main menu:  "Initial Setup"

Sub-menu 1	Sub-menu 2	Settings	Code	
Ringer Setup	Ringer Volume – Handset ^{*8}	0–6: Off–6 <6>	#160	17
	Ringer Volume – Base Unit ^{*1, *2}	0–6: Off–6 <3>	#*160	–
	Ringtone ^{*9, *10} (Handset)	<Ringtone 1>	#161	–
	Night Mode – On/Off	1: On 0: <Off>	#238	27
	Night Mode – Start/End	<23:00/06:00>	#237	28
	Night Mode – Ring Delay	1: 30 sec. 2: <60 sec.> 3: 90 sec. 4: 120 sec. 0: No Ringing	#239	28
Time Settings	Set Date/Time ^{*2}	–	#101	15
	Alarm	1: Once 2: Daily 0: <Off>	#720	27
	Time Adjustment ^{*2, *6}	1: Caller ID 0: <Manual>	#226	–
Handset Name	–	–	#104	28
Caller Barred ^{*2}	–	–	#217	28
Eco Setup	Transmission Power ^{*2}	1: <Normal> 2: Low	#725	16
Display Setup	LCD & Key Backlight	1: <On> 0: Off	#276	–
	Contrast (Display contrast)	1–6: Level 1–6 <3>	#145	–
Keytones ^{*11}	–	1: <On> 0: Off	#165	–
Call Restrict ^{*2}	–	–	#256	29
Auto Talk ^{*12}	–	1: On 0: <Off>	#200	17

Programming

Sub-menu 1	Sub-menu 2	Settings	Code	↵
Line Setup	Dial Mode ^{*2}	1: Pulse 2: <Tone>	#120	15
	Recall/Flash ^{*2, *13, *14}	0: 900 msec. 1: 700 msec. 2: <600 msec.> 3: 400 msec. 4: 300 msec. 5: 250 msec. *: 200 msec. #: 160 msec. 6: 110 msec. 7: 100 msec. 8: 90 msec. 9: 80 msec.	#121	18
Privacy Mode ^{*2, *15}	–	1: On 0: <Off>	#194	–
Base Unit PIN ^{*2}	–	<0000>	#132	29
Repeater Mode ^{*2}	–	1: On 0: <Off>	#138	30
Register	Register H.set	–	#130	30
	Cancel Register ^{*3}	–	#131	30
Country ^{*2}	–	1: <Other> 2: Česká rep. 3: Slovensko	#136	29
Power Failure	–	1: <Auto> 0: Off	#152	19
Language	Display	<English>	#110	15

*1 KX-TG6621

*2 If you program these settings using one of the handsets, you do not need to program the same item using another handset.

*3 This menu is not displayed when scrolling through the display menus. It is only available in direct command code.

*4 If you select the unit's region setting (page 29) to "Česká rep." or "Slovensko", the default setting will be changed for the selected country.

*5 If you select the unit's region setting (page 29) to "Česká rep." or "Slovensko", the default setting is "on".

*6 This feature allows the unit to automatically adjust the date and time each time caller information including date and time is received.
To turn this feature on, select "Caller ID". To turn this feature off, select "Manual". (Caller ID subscribers only)
To use this feature, set the date and time first (page 15).

*7 KX-TG6611/KX-TG6612

*8 Ringer volume cannot be turned off for alarm, intercom calls, and paging.

*9 If you select one of the melody ringer tones, the ringer tone continues to play for several seconds even if the caller has already hung up. You may either hear a dial tone or no one on the line when you answer the call.

*10The preset melodies in this product are used with permission of © 2011 Copyrights Vision Inc.

*11Turn this feature off if you prefer not to hear key tones while you are dialling or pressing any keys, including confirmation tones and error tones.

Programming

- *12 If you subscribe to a Caller ID service and want to view the caller's information after lifting up the handset to answer a call, turn off this feature.
- *13 The recall/flash time depends on your telephone exchange or host PBX. Contact your PBX supplier if necessary.
- *14 The default setting will be as follows if you select the following regional codes when changing the unit's region setting (page 29):
 - "Česká rep." = "100 msec."
 - "Slovensko" = "100 msec."
- *15 To prevent other users from joining your conversations with outside callers, turn this feature on.

Special programming

Alarm

An alarm sounds at the set time for 3 minutes once or daily. Alarm can be set for each handset.

Important:

- Set the date and time beforehand (page 15).

- 1 # 7 2 0
- 2 : Select the desired alarm option. → **OK**

"Off"	Turns alarm off. Go to step 6.
"Once"	An alarm sounds once at the set time.
"Daily"	An alarm sounds daily at the set time. Go to step 4.

- 3 Enter the desired date and month. → **OK**
- 4 Set the desired time. → **OK**
- 5 : Select the desired alarm tone. → **OK**
 - We recommend selecting a different ringer tone from the one used for outside calls.
- 6 **OK** →
 - When the alarm is set, is displayed.

Note:

- To stop the alarm, press or place the handset on the base unit or charger.
- When the handset is in use, the alarm will not sound until the handset is in standby mode.

Night mode

Night mode allows you to select a period of time during which the handset will not ring for outside calls. This feature is useful for time periods when you do not want to be disturbed, for example, while sleeping. Night mode can be set for each handset.

Important:

- Set the date and time beforehand (page 15).
- We recommend turning the base unit ringer off (page 25) in addition to turning the night mode on. (KX-TG6621)
- If you have set the alarm, the alarm sounds even if the night mode is turned on.

Turning night mode on/off

- 1 # 2 3 8
- 2 : Select the desired setting. → **OK**
 - If you select "off", press to exit.
- 3 Enter the desired hour and minute you wish to start this feature. → **OK**
 - You can select 24-hour or 12-hour clock format ("AM" or "PM") by pressing **12/24**.
- 4 Enter the desired hour and minute you wish to end this feature. → **OK**

Programming

5 [🔓]

- When the night mode is set, 🌙 is displayed.

Changing the start and end time

- 1 [📄] [#] [2] [3] [7]
- 2 Continue from step 3, "Turning night mode on/off", page 27.

Setting the ring delay

This setting allows the handset to ring during night mode if the caller waits long enough. After the selected amount of time passes, the handset rings. If you select "No Ringing", the handset never rings during night mode.

- 1 [📄] [#] [2] [3] [9]
- 2 [↕]: Select the desired setting. → **OK**
→ [🔓]

Note:

- When the answering system answers the call, this feature does not work. (KX-TG6621)

Changing the handset name

Each handset can be given a customised name ("Bob", "Kitchen", etc.). This is useful when you make intercom calls between handsets. You can also select whether or not the handset name is displayed in standby mode. The default setting is "No". If you select "Yes" without entering any handset name, "Handset 1" to "Handset 6" is displayed.

- 1 [📄] [#] [1] [0] [4]
- 2 Enter the desired name (max. 10 characters; page 44).
 - If not required, go to step 3.
- 3 **OK**
- 4 [↕]: Select the desired setting. → **OK** 2 times
- 5 [🔓]

Incoming call barring (Caller ID subscribers only)

This feature allows the unit to reject calls from specified phone numbers that you do not want to answer such as junk calls.

When a call is received, the unit does not ring while the caller is being identified. If the phone number matches an entry in the call barred list, the unit sends out a busy tone to the caller, and then disconnects the call.

Important:

- When the unit receives a call from a number that is stored in the call barred list, the call is logged in the caller list (page 32) with 📞 after the call is disconnected.

Storing unwanted callers

You can store up to 30 phone numbers in the call barred list.

Important:

- You must store the phone number with an area code in the call barred list.

■ From the caller list:

- 1 [←] (→)
- 2 [↕]: Select the entry to be barred. → **OK**
- 3 [↕]: "Caller Barred" → **OK**
- 4 [↕]: "Yes" → **OK** → [🔓]

■ By entering phone numbers:

- 1 [📄] [#] [2] [1] [7] → **OK**
- 2 Enter the phone number (24 digits max.). → **OK**
 - To erase a digit, press **C**.
- 3 [🔓]

Viewing/editing/erasing bar call numbers

- 1 [📄] [#] [2] [1] [7]
- 2 [↕]: Select the desired entry.
 - To exit, press [🔓].
- 3 **To edit a number:**
[📄] → Edit the phone number. → **OK**
→ [🔓]
To erase a number:
[X] → [↕]: "Yes" → **OK** → [🔓]

Note:

- When editing, press the desired dial key to add, **C** to erase.

Programming

Setting call restriction

You can restrict selected handsets from dialling certain numbers. You can assign up to 6 phone numbers to be restricted, and select which handsets are to be restricted. Storing area codes here prevents the restricted handsets from dialling any phone number in that area code.

- 1 # 2 5 6
- 2 Enter the base unit PIN (default: "0000").
 - If you forget your PIN, contact an authorised service centre.
- 3 [\updownarrow]: Select the handsets to be restricted. →
 - All handsets registered to the base unit are displayed.
 - "✓" is displayed next to the selected handset numbers.
 - To cancel a selected handset, press again. "✓" disappears.
- 4
- 5 [\updownarrow]: Select a memory location. →
- 6 Enter the phone number or area code to be restricted (8 digits max.). → → [X O]
 - To erase a restricted number, press .

Note:

- You can also select a memory location in step 5 as follows:
Press **1** to **6**. →

Changing the base unit PIN (Personal Identification Number)

Important:

- If you change the PIN, please make note of your new PIN. The unit will not reveal the PIN to you. If you forget your PIN, contact an authorised service centre.

- 1 # 1 3 2
- 2 Enter the current 4-digit base unit PIN (default: "0000").
- 3 Enter the new 4-digit base unit PIN. → → [X O]

Changing the unit's region setting/Resetting the base unit

- 1 # 1 3 6
- 2 [\updownarrow]: Select the desired country. →

"Other" = countries except Czech and Slovakia
 "Česká rep." = Czech
 "Slovensko" = Slovakia
- 3 [\updownarrow]: "yes" → → [X O]

Note:

- The following items will be deleted or reset to their default settings:
 - SMS settings (page 24)
 - Answering system settings (KX-TG6621, page 23)
 - Time Adjustment
 - Base unit ringer volume (KX-TG6621)
 - Base unit transmission power
 - Privacy mode
 - Base unit PIN
 - Dial mode
 - All SMS messages
 - Caller list
 - Voice mail messages
 - Call restrict
- The following items will be retained:
 - Display language
 - Date and time
 - Handset name
 - Repeater mode
 - Recordings, including your greeting message and caller messages (KX-TG6621)
 - Call screening (KX-TG6621)
 - Call barred list
- If you select the desired country in step 2, the following default settings will be changed for the selected country's default settings:
 - Recall/flash time (page 26)
 - Message centre 1 and 2 (page 24)
 - SMS on/off (page 24)

Programming

- According to your country selection in step 2, the answering system announcement language changes as follows (KX-TG6621):
 - “other” = English
 - “česká rep.” = Czech
 - “slovensko” = Slovak
- After changing the unit's region setting/ resetting the base unit, Ψ is displayed on the handset momentarily. This is normal and the handset can be used once Ψ is displayed.

Registering a unit

Operating additional units

Additional handsets

Up to 6 handsets can be registered to the base unit.

Important:

- The additional handset model recommended for use with this unit is noted on page 5. If another handset model is used, certain operations (handset settings, base unit settings, etc.) may not be available.

Registering a handset to the base unit

The supplied handset and base unit are pre-registered. If for some reason the handset is not registered to the base unit (for example, Ψ is displayed even when the handset is near the base unit), re-register the handset.

- Handset:**
 # 1 3 1 0
- Base unit:**
 Proceed with the operation for your model.
 - **KX-TG6611/KX-TG6612**
 Press and hold **[*]** for about 5 seconds. (No registration tone)

■ KX-TG6621

Press and hold **[*]** for about 5 seconds, until the registration tone sounds.

- If all registered handsets start ringing, press **[*]** again to stop, then repeat this step.
- The next step must be completed within 90 seconds.

3 Handset:

- **OK** → Wait until “Base PIN” is displayed. → Enter the base unit PIN (default: “0000”). → **OK**
- If you forget your PIN, contact an authorised service centre.
- When the handset has been registered successfully, Ψ is displayed.

Note:

- While registering, “Base in registering” is displayed on all registered handsets.
- When you purchase an additional handset, refer to the additional handset's installation manual for registration.

Deregistering a handset

A handset can cancel its own registration to the base unit, or other handsets registered to the same base unit. This allows the handset to end its wireless connection with the system.

-  # 1 3 1**
 - All handsets registered to the base unit are displayed.
- [↓]**: Select the handset you want to cancel. → **OK**
- [↓]**: “yes” → **OK**
 - A confirmation tone sounds.
 - The handset does not beep when cancelling its own registration.
- [*]**

Increasing the range of the base unit

You can increase the signal range of the base unit by using a DECT repeater. Please use only the Panasonic DECT repeater noted on page 4. Contact your Panasonic dealer for details.

Programming

Important:

- Before registering the repeater to this base unit, you must turn the repeater mode on.
- Do not use more than one repeater at a time.

Setting the repeater mode

- 1 # 1 3 8
- 2 : Select the desired setting. → **OK**
→

Note:

- After turning the repeater mode on or off, is displayed on the handset momentarily. This is normal and the handset can be used once is displayed.

Registering the DECT repeater (KX-A405) to the base unit

Note:

- Please use a repeater that has not yet been registered to another unit. If the repeater is registered to another unit, deregister it first, referring to the Installation Guide for the DECT repeater.

- 1 **Base unit:**
Proceed with the operation for your model.
 - **KX-TG6611/KX-TG6612**
Press and hold for about 5 seconds. (No registration tone)
 - **KX-TG6621**
Press and hold for about 5 seconds, until the registration tone sounds.
 - The next step must be completed within 90 seconds.
- 2 **DECT repeater:**
Connect the AC adaptor, then wait until the indicator and indicator light green.
- 3 **Base unit:**
To exit the registration mode, press .
 - The registration tone stops. (KX-TG6621)

Caller ID Service

Using Caller ID service

Important:

- This unit is Caller ID compatible. To use Caller ID features, you must subscribe to a Caller ID service. Contact your service provider/telephone company for details.

Caller ID features

When an outside call is being received, the caller's phone number is displayed. Caller information for the last 50 callers is logged in the caller list from the most recent call to the oldest.

- If the unit cannot receive caller information, the following is displayed:
 - “**Out of Area**”: The caller dials from an area which does not provide a Caller ID service.
 - “**Private Caller**”: The caller requests not to send caller information.
- If the unit is connected to a PBX system, caller information may not be properly received. Contact your PBX supplier.

Missed calls

If a call is not answered, the unit treats it as a missed call and **↻** is displayed. This lets you know if you should view the caller list to see who called while you were away.

Even if only one missed call in the caller list is viewed (page 32), **↻** disappears from the display. When you receive another new call, **↻** is displayed again.

Note:

- Even when there are unviewed missed calls, **↻** disappears from the standby display if the following operation is performed by one of the registered handsets:
 - Being replaced on the base unit or charger.
 - Pressing **[↻⏻]**.

Phonebook name display

When caller information is received and it matches a phone number stored in the phonebook, the stored name in the phonebook is displayed and logged in the caller list.

Caller list

Important:

- Only 1 person can access the caller list at a time.
- Make sure the unit's date and time setting is correct (page 15).

Viewing the caller list and calling back

- 1 **[←] (↻)**
- 2 Press **[↻]** to search from the most recent call, or press **[▲]** to search from the oldest call.
 - If **▶** is displayed, not all of the information is shown. To see the remaining information, press **[▶]**. To return to the previous screen, press **[←]**.
- 3 To call back, press **[↻]**. To exit, press **[↻⏻]**.

Note:

- If the entry has already been viewed or answered, “**✓**” is displayed, even if it was viewed or answered using another handset.
- If the call matches an entry in the call barred list, the number is logged with **✖** (page 28).

Editing a caller's phone number before calling back

- 1 **[←] (↻)**
- 2 **[↕]**: Select the desired entry.
- 3 **[↻]** → Edit the number.
 - Press dial key (**[0]** to **[9]**) to add, **[C]** to delete.
- 4 **[↻]**

Caller ID Service

Erasing selected caller information

- 1 [←] (→)
- 2 [↓]: Select the desired entry.
- 3 **X** → [↓]: "Yes" → **OK** → [↵]

Erasing all caller information

- 1 [←] (→)
- 2 **X** → [↓]: "Yes" → **OK** → [↵]

Storing caller information to the phonebook

- 1 [←] (→)
- 2 [↓]: Select the desired entry. → **PS**
- 3 [↓]: "Phonebook" → **OK**
- 4 To store the name, continue from step 2, "Adding entries", page 21.

SMS (Short Message Service)

Using SMS

SMS allows you to send and receive text messages between other fixed-line and mobile phones that support compatible SMS networks and features.

Important:

- To use SMS features, you must:
 - subscribe to a Caller ID and/or an appropriate service such as SMS.
 - confirm that SMS is turned on.
 - confirm that the correct message centre numbers are stored.

Contact your service provider/telephone company for details and availability.

Note:

- A total of 47 messages (at 160 characters/message) can be saved. Total number may be more than 47 if length of messages is less than 160 characters/message.
- If the unit is connected to a PBX system, you may not be able to use SMS features.

Turning SMS on/off

- 1  #357
- 2 [↕]: Select the desired setting. → **OK**
→ [↵]

Storing SMS message centre numbers

SMS message centre numbers must be stored in order to send and receive SMS messages.

For Czech:

The message centre numbers (used for SMS services provided by Telefonica O2) are preprogrammed in this unit. You can change them if necessary.

For Slovakia:

The message centre numbers (used for SMS service provided by Slovak Telecom - T-Com) are preprogrammed in this unit. You can change them if necessary.

- Contact your service provider/telephone company for more information.
- If you change the unit's region setting/reset the base unit, the stored message centre numbers will be deleted or changed (page 24). In this case, store the numbers again if necessary.

1 To store "Message Centre1":

 #351

To store "Message Centre2":

 #352

- 2 Edit the number as necessary. → **OK**
→ [↵]

Note:

- For PBX users:
 - You need to add the PBX line access number and a dialling pause to the beginning of the Message Centre 1 number.
 - If you only use the Message Centre 1 number for SMS, store the Message Centre 1 number as is (without adding a line access number or dialling pause) to Message Centre 2.

Sending a message

Writing and sending a new message

- 1  #350
- 2 [↕]: "Create" → **OK**
- 3 Enter a message. → **OK**
 - You can change the character entry mode by pressing **1/A/R** (page 44).
- 4 Enter the destination phone number (20 digits max.). → **OK**

To use the redial list:
[>] (●) → [↕]: Select the phone number. → **OK** 2 times

To use the caller list:
[<] (→) → [↕]: Select the party. → **OK** 2 times

 - If ▶ is displayed, not all of the information is shown. To see the remaining information, press [▶]. To

return to the previous screen, press [←].

To use the phonebook:

[📧] → [↕]: Select the phonebook entry. → **OK** 2 times

- 5 To save the message, select "Yes". → **OK**
- 6 To send the message, press **OK**.
 - To cancel sending, press [⏏].

Note:

- This unit supports SMS messages of up to 160 characters, however, the maximum number of characters you can send or receive may be limited by your SMS service provider/telephone company. Contact your SMS service provider/telephone company for details.
- If your message contains over 160 characters, the message is a long message and "***Long Text**" is displayed. Your service provider/telephone company may treat long messages differently from other messages. Contact your service provider/telephone company for details.
- If your phone is connected to a PBX, store the PBX line access number (page 36).

Editing/sending a saved message

- 1 [📧] #350
- 2 [↕]: "Send List" → **OK**
- 3 To read a saved message, press [▼] or [▲] to select the message. → **OK**
- 4 **To edit the message:**
 [📧] → [↕]: "Edit Message" → **OK**
 → Continue from step 3, "Writing and sending a new message", page 34.
To send the message:
 [📧] → [↕]: "Send" → **OK** → Press and hold **C** to erase all numbers. → Continue from step 4, "Writing and sending a new message", page 34.

Erasing saved messages

- 1 [📧] #350
- 2 [↕]: "Send List" → **OK**

SMS (Short Message Service)

- 3 [↕]: Select a message. → **OK**
- 4 [📧] → [↕]: "Erase" → **OK**
 - To erase all messages, select "Erase All". → **OK**
- 5 [↕]: "Yes" → **OK** → [⏏]

Receiving a message

- When an SMS message is received:
- "Receiving SMS Message" is displayed.
 - a tone is heard (if the handset ringer is turned on).
 - [📧] is displayed with the total number of new (unread) SMS messages.

Reading a received message

- 1 [📧] #350
- 2 [↕]: "Receive List" → **OK**
- 3 [↕]: Select a message.
 - Messages which have already been read are indicated by a "✓", even if they were read using another handset.
 - To erase a message, press **X**. → [↕]: "Yes" → **OK**
- 4 Press **OK** to read the message content.

Note:

- To call the message sender, press [☎].

Replying to a message

- 1 While reading a received message, press [📧].
- 2 [↕]: "Reply" → **OK**
- 3 Enter a message (page 44). → **OK**
- 4 Edit the destination phone number if necessary. → **OK**
- 5 Continue from step 5, "Writing and sending a new message", page 34.

Editing/forwarding a message

- 1 While reading a received message, press [📧].
- 2 [↕]: "Edit Message" → **OK**

SMS (Short Message Service)

- 3 Continue from step 3, "Writing and sending a new message", page 34.

Erasing received messages

- 1 While reading a received message, press .
- 2 [↕]: "Erase" → **OK**
 - To erase all messages, select "Erase All". → **OK**
- 3 [↕]: "Yes" → **OK** → [**⌂**]

Storing the sender's number in the phonebook

- 1 While reading a received message, press .
- 2 [↕]: "Add Phonebook" → **OK**
- 3 To store the name, continue from step 2, "Adding entries", page 21.

Editing the sender's number before calling back

- 1 While reading a received message, press .
- 2 [↕]: "Edit & Call" → **OK**
- 3 Edit the number. → [**↶**]

Other settings

Storing the PBX line access number (for PBX users only)

Store your PBX line access number (4 digits max.) so that SMS messages are sent properly. When sending SMS messages to entries in the phonebook or redial list, the PBX line access number is deleted. The default setting is "0xx".

- 1  #356
- 2 [↕]: "On" → **OK**
- 3 Enter your PBX line access code and a dialling pause, if necessary. → **OK** → [**⌂**]

Answering System

announced to callers even though their messages are not recorded.

Answering system

Available for:
KX-TG6621

The answering system can answer and record calls for you when you are unavailable to answer the phone.

You can also set the unit to play a greeting message but not to record caller messages by selecting "Greeting Only" as the recording time setting (page 41).

Important:

- Only 1 person can access the answering system (listen to messages, record a greeting message, etc.) at a time.
- When callers leave messages, the unit records the day and time of each message. Make sure the date and time have been set correctly (page 15).

Memory capacity (including your greeting message)

The total recording capacity is about 15 minutes. A maximum of 64 messages can be recorded.

Note:

- When message memory becomes full:
 - "Messages Full" is shown on the handset display.
 - The answer on indicator on the base unit flashes rapidly if the answering system is turned on.
 - The message counter on the base unit flashes if the answering system is turned on.
 -  and the total number of new messages are not displayed on the handset even if the answering system is turned on.
 - If you use the pre-recorded greeting message, the unit automatically switches to another pre-recorded greeting message asking callers to call again later.
 - If you recorded your own greeting message, the same message is still

Turning the answering system on/off

The answering system is preset to on.

Base unit



Press  to turn on/off the answering system.

- When the answering system is turned on:
 - The answer on indicator lights up.
 - The message counter displays the total number of messages (old and new).

Handset

1 To turn on:
 # 3 2 7



To turn off:
 # 3 2 8

2  



Note:

- When the answering system is turned on,  is displayed next to the battery icon.

Call screening

While a caller is leaving a message, you can listen to the call through the handset's speaker. To adjust the speaker volume, press  or  repeatedly. You can answer the call by pressing  on the handset. Call screening can be set for each handset. The default setting is "On".

1  # 3 1 0

2 : Select the desired setting. → **OK**
→ 

Answering System

Greeting message

When the unit answers a call, a greeting message is played to callers. You can use either:

- your own greeting message
- a pre-recorded greeting message

Recording your greeting message

- 1 #302
- 2 [\uparrow]: "Yes" → **OK**
- 3 After a beep sounds, hold the handset about 20 cm away and speak clearly into the microphone (50 seconds max.).
- 4 Press to stop recording.
- 5 [\cancel]

Using a pre-recorded greeting message

The unit provides 2 pre-recorded greeting messages:

- If you erase or do not record your own greeting message, the unit plays a pre-recorded greeting asking callers to leave a message.
- If the message recording time (page 41) is set to "Greeting Only", callers' messages are not recorded and the unit plays a different pre-recorded greeting message asking callers to call again.

Resetting to a pre-recorded greeting message

If you want to use a pre-recorded greeting message once you record your own greeting message, you need to erase your own greeting message.

- 1 #304
- 2 **OK** → [\cancel]

Playing back the greeting message

- 1 #303
- 2 [\cancel]

Listening to messages using the base unit

When new messages have been recorded, **[▶]** on the base unit flashes.

Press **[▶]**.

- If new messages have been recorded, the base unit plays back new messages.
- If there are no new messages, the base unit plays back all messages.

Operating the answering system during playback

Key	Operation
[+] or [-]	Adjust the speaker volume
[◀◀]	Repeat message ^{*1}
[▶▶]	Skip message
[■]	Stop playback
[X]	Erase currently playing message

*1 If pressed within the first 5 seconds of a message, the previous message is played.

Erasing all messages

Press **[X]** 2 times while the unit is not in use.

Answering System

Listening to messages using the handset

When new messages have been recorded,  is displayed on the handset with the total number of new messages.

1 To listen to new messages:

 # 3 2 3

To listen to all messages:

 # 3 2 4







2 When finished, press [].

Note:

- To switch to the receiver, press [].

Operating the answering system

 → []: "Answer System" → **OK**



Key	Operation
[] or []	Adjust the receiver or speaker volume (during playback)
[1] or []	Repeat message (during playback) ^{*1}
[2] or []	Skip message (during playback)
[3]	Enter the "Settings" menu
[4]	Play new messages
[5]	Play all messages
[6]	Play greeting message
[7] [6]	Record greeting message
[8]	Turn answering system on
	Pause message ^{*2}
[9] or []	Stop recording Stop playback
[0]	Turn answering system off
[*] [4] ^{*3}	Erase currently playing message
[*] [5]	Erase all messages
[*] [6]	Reset to a pre-recorded greeting message

*1 If pressed within the first 5 seconds of a message, the previous message is played.

*2 To resume playback:

[]: "Play" → **OK**

*3 You can also erase as follows:

[] → []: "Yes" → **OK**

Calling back (Caller ID subscribers only)

If caller information is received for the call, you can call the caller back while listening to a message.

1 Press  during playback.

2 []: "Call Back" → **OK**

Editing the number before calling back



1 Press  during playback.

2 []: "Edit & Call" → **OK**

3 Edit the number. → []

Erasing all messages

1  # 3 2 5

2 []: "Yes" → **OK** → []

Remote operation

Using a touch-tone phone, you can call your phone number from outside and access the unit to listen to messages or change answering system settings.

Remote access code

A 3-digit remote access code must be entered when operating the answering system remotely. This code prevents unauthorised parties from listening to your messages remotely.

Important:

- In order to operate the answering system remotely, you must first set a remote access code.

1  # 3 0 6

Answering System

- 2 To turn on remote operation, enter the desired 3-digit remote access code.
- 3 **OK** → **[*][*][*]**

Deactivating remote operation

Press **[*]** in step 2 on "Remote access code", page 39.

- The entered remote access code is deleted.

Using the answering system remotely

- 1 Dial your phone number from a touch-tone phone.
- 2 After the greeting message starts, enter your remote access code.
- 3 Enter remote commands.
- 4 When finished, hang up.

Remote commands

Key	Operation
[1]	Repeat message (during playback) ^{*1}
[2]	Skip message (during playback)
[4]	Play new messages
[5]	Play all messages
[6]	Play greeting message
[7]	Record greeting message
[9]	Stop recording Stop playback
[0]	Turn answering system off
[*][4]	Erase currently playing message
[*][5]	Erase all messages
[*][6]	Reset to a pre-recorded greeting message (during greeting message playback)
[*][#]	End remote operation (or hang up)

*1 If pressed within the first 5 seconds of a message, the previous message is played.

Turning on the answering system remotely

If the answering system is off, you can turn it on remotely.

- 1 Dial your phone number from a touch-tone phone.
- 2 Let the phone ring 9 times.
 - A long beep is heard.
- 3 Enter your remote access code within 10 seconds after the long beep.
 - The greeting message is played back.
 - You can either hang up, or enter your remote access code again and begin remote operation (page 39).

Answering system settings

Number of rings before the unit answers a call

You can change the number of times the phone rings "Number of Rings" before the unit answers a call. You can select 2 to 6 rings, or "Auto".

The default setting is "4 Rings".

"Auto": The unit's answering system answers at the end of the 2nd ring when new messages have been recorded, or at the end of the 5th ring when there are no new messages. If you call your phone from outside to listen to new messages (page 40), you know that there are no new messages when the phone rings for the 3rd time. You can then hang up without being charged for the call.

- 1 **[*][#][2][1][1]**
- 2 **[*][*]**: Select the desired setting. → **OK** → **[*][*]**

For voice mail service subscribers

To receive voice mail and use answering system properly, please note the following:

- To use the voice mail service (page 42) provided by your service provider/ telephone company rather than the unit's

Answering System

answering system, turn off the answering system (page 37).

- To use this unit's answering system rather than the voice mail service provided by your service provider/telephone company, please contact your service provider/telephone company to deactivate your voice mail service.

If your service provider/telephone company cannot do this:

- Set this unit's "**Number of Rings**" setting so that this unit's answering system answers calls before the voice mail service of your service provider/telephone company does. It is necessary to check the number of rings required to activate the voice mail service provided by your service provider/telephone company before changing this setting.
- Change the number of rings of the voice mail service so that the answering system can answer the call first. To do so, contact your service provider/telephone company.

Caller's recording time

You can change the maximum message recording time allowed for each caller. The default setting is "**3 Minutes**".

1  **#305**

2 **[↑]**: Select the desired setting. → **OK**
→ **[↶]**

Selecting "Greeting Only"

You can select "**Greeting Only**" which sets the unit to announce a greeting message to callers but not record messages.

Select "**Greeting Only**" in step 2 on "Caller's recording time", page 41.

Note:



- When you select "**Greeting Only**":
 - If you do not record your own message, the unit will play the pre-recorded greeting-only message asking callers to call again later.
 - If you use your own message, record the greeting-only message asking callers to call again later (page 38).

Voice Mail Service

Voice mail service

Voice mail is an automatic answering service offered by your service provider/telephone company. After you subscribe to this service, your service provider/telephone company's voice mail system answers calls for you when you are unavailable to answer the phone or when your line is busy. Messages are recorded by your service provider/telephone company, not your telephone. When you have new messages,  is displayed on the handset if message indication service is available. Please contact your service provider/telephone company for details of this service.

Important:

- If  still remains on the display even after you have listened to new messages, turn it off by pressing and holding  for 2 seconds.
- To use the voice mail service provided by your service provider/telephone company rather than the unit's answering system, turn off the answering system (page 37). For details, see page 40. (KX-TG6621)

Intercom/Locator

Intercom

Intercom calls can be made between handsets.

Note:

- If you receive an outside call while talking on the intercom, you hear 2 tones. To answer the call, press [**⏏**], then press [**↶**].
- When paging the handset, the paged handset beeps for 1 minute.

Making an intercom call

- 1 [**☰**] → [**⏏**]
- 2 [**↕**]: Select the desired unit. → **OK**
 - To stop paging, press [**⏏**].
- 3 When you finish talking, press [**⏏**].

Answering an intercom call

- 1 Press [**↶**] to answer the page.
- 2 When you finish talking, press [**⏏**].

Handset locator

You can locate a misplaced handset by paging it.

- 1 **Base unit:** Press [**⏏**].
 - All registered handsets beep for 1 minute.
- 2 To stop paging:
 - Base unit:** Press [**⏏**].
 - Handset:** Press [**⏏**].

Transferring calls, conference calls

Outside calls can be transferred or a conference call with an outside party can be made between 2 handsets.

- 1 During an outside call, press [**⏏**] to put the call on hold.

- 2 [**↕**]: Select the desired unit. → **OK**
- 3 Wait for the paged party to answer.
 - If the paged party does not answer, press [**☰**] to return to the outside call.
- 4 **To complete the transfer:**
Press [**⏏**].
 - The outside call is being routed to the destination unit.

To establish a conference call:
☰ → [**↕**]: "Conference" → **OK**

 - To leave the conference, press [**⏏**]. The other 2 parties can continue the conversation.
 - To put the outside call on hold: **☰** → [**↕**]: "Hold" → **OK**
To resume the conference: **☰** → [**↕**]: "Conference" → **OK**

Note:

- If you want to return to the outside call after the paged party answers, press [**⏏**].

Answering a transferred call

Press [**↶**] to answer the page.

Useful Information

Character entry

The dial keys are used to enter characters and numbers. Each dial key has multiple characters assigned to it. The characters that can be entered depend on the character entry mode (page 44).

- Press [←] or [→] to move the cursor left or right.
- Press dial keys to enter characters and numbers.
- Press **[C]** to erase the character or number highlighted by the cursor. Press and hold **[C]** to erase all characters or numbers.
- Press **[A→a]** to switch between uppercase and lowercase.
- To enter another character located on the same dial key, press [→] to move the cursor to the next space, then press the appropriate dial key.
- If you do not press any dial key within 5 seconds after entering a character, the character is fixed and the cursor moves to the next space.

Character entry modes

The available character entry modes are Alphabet (ABC), Numeric (0-9), Greek (ΑΒΓ), Extended 1 (ΑΆΑ), Extended 2 (ΣΣΣ), and Cyrillic (АБВ). For SMS messages, Alphabet (ABC), Numeric (0-9), Greek (ΑΒΓ), and Extended 1 (ΑΆΑ) modes are available. When in these entry modes except Numeric, you can select which character is entered by pressing a dial key repeatedly.

When the unit displays the character entry screen:

1/A/2 → [↕]: Select a character entry mode. → **OK**

Note:

- _ in the following tables represents a single space.
- The dial keys with *1, *2, and *3 in the following tables have different character assignment for SMS. See the footnotes with *1, *2, and *3.

Alphabet character table (ABC)

0 _	1 &*1	2 ABC	3 DEF	4 GHI	5 JKL	6 MNO	7 PQRS	8 TUV	9 WXYZ	#
_ 0	& ' () * , - . / 1	A B C 2	D E F 3	G H I 4	J K L 5	M N O 6	P Q R S 7	T U V 8	W X Y Z 9	#
		a b c 2	d e f 3	g h i 4	j k l 5	m n o 6	p q r s 7	t u v 8	w x y z 9	

Numeric entry table (0-9)

0 _	1 &*1	2 ABC	3 DEF	4 GHI	5 JKL	6 MNO	7 PQRS	8 TUV	9 WXYZ	#
0	1	2	3	4	5	6	7	8	9	#

Greek character table (ΑΒΓ)

0 _	1 &*1	2 ABC	3 DEF	4 GHI	5 JKL	6 MNO	7 PQRS	8 TUV	9 WXYZ	#
_ 0	& ' () * , - . / 1	A B Γ 2	Δ E Z 3	H Θ I 4	K Λ M 5	N Ξ O 6	Π P Σ 7	T Υ Φ 8	X Ψ Ω 9	#

Useful Information

Error messages

Display message	Cause/solution
Base no power or No link. Reconnect AC adaptor. or No link.	<ul style="list-style-type: none"> • The handset has lost communication with the base unit. Move closer to the base unit and try again. • Unplug the base unit's AC adaptor to reset the unit. Reconnect the adaptor and try again. • The handset's registration may have been cancelled. Re-register the handset (page 30). • When "No link." is displayed during a power failure, place a handset on the base unit to supply power to the base unit.
Check Phone Line	<ul style="list-style-type: none"> • The supplied telephone line cord has not been connected yet or not connected properly. Check the connections (page 10).
Error ^{*1}	<ul style="list-style-type: none"> • Recording was too short. Try again.
Failed	<ul style="list-style-type: none"> • Phonebook copy failed (page 22). Confirm the other handset (the receiver) is in standby mode and try again.
Incomplete	<ul style="list-style-type: none"> • The receiver's phonebook memory is full. Erase the unwanted phonebook entries from the other handset (the receiver) and try again.
Invalid Number	<ul style="list-style-type: none"> • You tried to send an SMS message to a phone number saved in the phonebook, caller list, or redial list that is over 20 digits long.
Memory Full	<ul style="list-style-type: none"> • The phonebook memory is full. Erase unwanted entries (page 21). • Message memory is full. Erase unwanted messages (page 38, 39).^{*1} • The call barred list memory is full. Erase unwanted entries (page 28).
Use rechargeable battery.	<ul style="list-style-type: none"> • A wrong type of battery such as Alkaline or Manganese was inserted. Use only the rechargeable Ni-MH batteries noted on page 4, 7.
You must first subscribe to Caller ID.	<ul style="list-style-type: none"> • You must subscribe to a Caller ID service. Once you receive caller information after subscribing to a Caller ID service, this message will not be displayed.

*1 KX-TG6621

Troubleshooting

If you still have difficulties after following the instructions in this section, disconnect the base unit's AC adaptor and turn off the handset, then reconnect the base unit's AC adaptor and turn on the handset.

Useful Information**General use**



Problem	Cause/solution
The handset does not turn on even after installing charged batteries.	<ul style="list-style-type: none"> Place the handset on the base unit or charger to turn on the handset.
The unit does not work.	<ul style="list-style-type: none"> Make sure the batteries are installed correctly (page 11). Fully charge the batteries (page 11). Check the connections (page 10). Unplug the base unit's AC adaptor to reset the unit and turn off the handset. Reconnect the adaptor, turn on the handset and try again. The handset has not been registered to the base unit. Register the handset (page 30).
The handset display is blank.	<ul style="list-style-type: none"> The handset is not turned on. Turn the power on (page 15).
I cannot hear a dial tone.	<ul style="list-style-type: none"> Make sure that you are using the supplied telephone line cord. Your old telephone line cord may have a different wiring configuration. The base unit's AC adaptor or telephone line cord is not connected. Check the connections. Disconnect the base unit from the telephone line and connect the line to a known working telephone. If the working telephone operates properly, contact our service personnel to have the unit repaired. If the working telephone does not operate properly, contact your service provider/telephone company.

Programmable settings

Problem	Cause/solution
The display is in a language I cannot read.	<ul style="list-style-type: none"> Change the display language (page 15).
While programming, the display returns to standby mode.	<ul style="list-style-type: none"> A call matching an entry in the call barred list is being received. Wait and try again later.
I cannot activate the eco mode.	<ul style="list-style-type: none"> You cannot set eco mode when you set the repeater mode "On". If required, set the repeater mode to "Off" (page 31).
I cannot register a handset to a base unit.	<ul style="list-style-type: none"> The maximum number of handsets (6) is already registered to the base unit. Cancel unused handset registrations from the base unit (page 30). You entered the wrong PIN. If you forget your PIN, contact an authorised service centre.

Useful Information

Battery recharge

Problem	Cause/solution
The handset beeps and/or  flashes.	<ul style="list-style-type: none"> • Battery charge is low. Fully charge the batteries (page 11).
I fully charged the batteries, but <ul style="list-style-type: none"> –  still flashes or – the operating time seems to be shorter. 	<ul style="list-style-type: none"> • Clean the battery ends (\oplus, \ominus) and the charge contacts with a dry cloth and charge again. • It is time to replace the batteries (page 11).

Making/answering calls, intercom

Problem	Cause/solution
 is displayed.	<ul style="list-style-type: none"> • The handset is too far from the base unit. Move closer. • The base unit's AC adaptor is not properly connected. Reconnect AC adaptor to the base unit. • The handset is not registered to the base unit. Register it (page 30). • Activating one touch eco mode reduces the range of the base unit in standby mode. If required, turn eco mode off (page 16).
Noise is heard, sound cuts in and out.	<ul style="list-style-type: none"> • You are using the handset or base unit in an area with high electrical interference. Re-position the base unit and use the handset away from sources of interference. • Move closer to the base unit. • If you use a DSL/ADSL service, we recommend connecting a DSL/ADSL filter between the base unit and the telephone line jack. Contact your DSL/ADSL provider for details. • Unplug the base unit's AC adaptor to reset the unit and turn off the handset. Reconnect the adaptor, turn on the handset and try again.
Sound quality seems to be getting worse.	<ul style="list-style-type: none"> • You have registered a handset that is not recommended (page 5). The clearest sound quality is only possible by registering the recommended handset.
The handset does not ring.	<ul style="list-style-type: none"> • The ringer volume is turned off. Adjust ringer volume (page 17). • Night mode is turned on. Turn it off (page 27).
The base unit does not ring.*1	<ul style="list-style-type: none"> • The ringer volume is turned off. Adjust ringer volume (page 25).
I cannot make a call.	<ul style="list-style-type: none"> • The dialling mode may be set incorrectly. Change the setting (page 15). • The handset is too far from the base unit. Move closer and try again. • Another unit is in use. Wait and try again later. • Answering system is being used.*1 Wait and try again later. • You dialled a call restricted number (page 29). • The key lock feature is turned on. Turn it off (page 19).

*1 KX-TG6621

Useful Information

Caller ID

Problem	Cause/solution
Caller information is not displayed.	<ul style="list-style-type: none"> You must subscribe to a Caller ID service. Contact your service provider/telephone company for details. If your unit is connected to any additional telephone equipment, remove and plug the unit directly into the wall jack. If you use a DSL/ADSL service, we recommend connecting a DSL/ADSL filter between the base unit and the telephone line jack. Contact your DSL/ADSL provider for details. Other telephone equipment may be interfering with this unit. Disconnect the other equipment and try again.
Caller information is slow to display.	<ul style="list-style-type: none"> Depending on your service provider/telephone company, the unit may display the caller's information at the 2nd ring or later. Move closer to the base unit.
Time on the unit has shifted.	<ul style="list-style-type: none"> Incorrect time information from incoming Caller ID changes the time. Set the time adjustment to "Manual" (off) (page 24).
The name stored in the phonebook is not fully displayed while an outside call is being received.	<ul style="list-style-type: none"> Edit the phonebook entry name to fit in 1 line of text (page 21).

SMS (Short Message Service)

Problem	Cause/solution
The SMS message centre number is logged in the caller list and the message is not received.	<ul style="list-style-type: none"> Someone tried to send you a message while SMS is turned off. Turn it on (page 34).
I cannot send or receive SMS messages.	<ul style="list-style-type: none"> You have not subscribed to the appropriate service. Contact your service provider/telephone company. The SMS message centre number(s) are not stored or are incorrect. Store the correct numbers (page 34). Message transmission was interrupted. Wait until the message has been sent before using other telephone functions. If you use a DSL/ADSL service, we recommend connecting a DSL/ADSL filter between the base unit and the telephone line jack. Contact your DSL/ADSL provider for details.
"FD" is displayed.	<ul style="list-style-type: none"> The unit could not connect to the SMS message centre. Confirm that the correct SMS message centre numbers are stored. Confirm that SMS is turned on (page 34).
"FE" is displayed.	<ul style="list-style-type: none"> An error occurred while sending the message. Try again.
"E0" is displayed.	<ul style="list-style-type: none"> Your phone number is permanently withheld or you have not subscribed to the appropriate service. Contact your service provider/telephone company.

Useful Information

Answering system (KX-TG6621)

Problem	Cause/solution
The unit does not record new messages.	<ul style="list-style-type: none"> • The answering system is turned off. Turn it on (page 37). • The message memory is full. Erase unwanted messages (page 38). • The recording time is set to "Greeting Only". Change the setting (page 41). • If your own greeting message is not recorded properly, callers are unable to leave a message. Record your own greeting message again (page 38). • If you subscribe to a voice mail service, messages are recorded by your service provider/telephone company, not your telephone. Change the unit's number of rings setting or contact your service provider/telephone company (page 40).
My own greeting message cannot be properly heard.	<ul style="list-style-type: none"> • Record your own greeting message again (page 38).
I cannot operate the answering system.	<ul style="list-style-type: none"> • Someone is using the unit. Wait for the other user to finish. • A caller is leaving a message. Wait for the caller to finish. • The handset is too far from the base unit. Move closer.
I cannot operate the answering system remotely.	<ul style="list-style-type: none"> • The remote access code is not set. Set the remote access code (page 39). • You are entering the wrong remote access code. If you have forgotten your remote access code, enter the remote access code setting to check your current code (page 39). • Press each key firmly. • The answering system is turned off. Turn it on (page 40).

Liquid damage

Problem	Cause/solution
Liquid or other form of moisture has entered the handset/base unit.	<ul style="list-style-type: none"> • Disconnect the AC adaptor and telephone line cord from the base unit. Remove the batteries from the handset and leave to dry for at least 3 days. After the handset/base unit are completely dry, reconnect the AC adaptor and telephone line cord. Insert the batteries and charge fully before use. If the unit does not work properly, contact an authorised service centre.

Caution:

- To avoid permanent damage, do not use a microwave oven to speed up the drying process.

Index

- A**
 - Additional handsets: 30
 - Alarm: 27
 - Answering calls: 17
 - Answering system: 37
 - Call screening: 37
 - Erasing messages: 38, 39, 40
 - Greeting message: 38
 - Greeting only: 41
 - Listening to messages: 38, 39, 40
 - Number of rings: 40
 - Recording time: 41
 - Remote access code: 39
 - Remote operation: 39
 - Turning on/off: 37, 39, 40
 - Auto talk: 17
- B**
 - Base unit
 - Resetting: 29
 - Battery: 11
- C**
 - Caller ID service: 32
 - Caller list: 32
 - Caller list edit: 32
 - Call restriction: 29
 - Call share: 19
 - Call waiting: 18
 - Call Waiting Caller ID: 18
 - Chain dial: 21
 - Character entry: 44
 - Conference calls: 43
 - Control type: 13
- D**
 - Date and time: 15
 - Dialling mode: 15
 - Direct command code: 23
 - Display
 - Contrast: 25
 - Language: 15
- E**
 - Eco mode: 16
 - Equalizer: 18
 - Error messages: 46
- H**
 - Handset
 - Deregistration: 30
 - Locator: 43
 - Name: 28
 - Registration: 30
 - Hold: 18
- I**
 - Incoming call barring: 28
 - Intercom: 43
- K**
 - Key lock: 19
 - Keytones: 25
- M**
 - Making calls: 17
 - Missed calls: 32
 - Mute: 18
- N**
 - Night mode: 27
- P**
 - Pause: 17
 - Phonebook: 21
 - PIN: 29
 - Power failure (power back-up operation): 19
 - Power on/off: 15
 - Privacy mode: 26
- R**
 - Recall/flash: 18
 - Redialling: 17
 - Region setting: 29
 - Repeater: 30
 - Ringer tone: 25
- S**
 - SMS feature: 34
 - Speakerphone: 17
- T**
 - Temporary tone dialling: 18
 - Time adjustment: 24
 - Transferring calls: 43
 - Troubleshooting: 46
- V**
 - Voice mail: 42
 - Volume
 - Receiver: 17
 - Ringer (Base unit): 25
 - Ringer (Handset): 17, 25
 - Speaker: 17
- W**
 - Wall mounting: 16

CE0470

Sales Department:

■ Czech

Panasonic Marketing Europe
GmbH, organizační složka
Česká republika

Thámova 289/13 (Palác Karlín)
186 00 Praha 8

telefon: +420-236 032 511
centrální fax: +420-236 032 411
zákaznická linka: +420-236 032 911
e-mail: panasonic.praha@eu.panasonic.com
e-mail: servis.praha@eu.panasonic.com
aktuální info na www.panasonic.cz

■ Slovakia

Panasonic Marketing Europe
GmbH, organizačná zložka
Slovenská republika

Štúrova 11, 811 02 Bratislava,
Slovenská republika

Telefón: +421-2-2062-2211
Fax: +421-2-2062-2313
zákaznická linka: +421-2-2062-2911
e-mail: servis.bratislava@eu.panasonic.com
aktuálne info na www.panasonic.sk

■ Romania

Panasonic Marketing Europe
GmbH, Wiesbaden, Germania,
Sucursala București, Romania

B-dul Preciziei, Nr. 24, West Gate Park,
Clădirea H3, Etaj 2, Sector 6,
București, 062204, Romania

Telefon: +40.21.316.31.61
Fax: +40.21.316.04.46
e-mail: suport.clienti@eu.panasonic.com
web: www.panasonic.ro

Panasonic System Networks Co., Ltd.

1-62, 4-chome, Minoshima, Hakata-ku, Fukuoka 812-8531, Japan

© Panasonic System Networks Co., Ltd. 2011



TG6611 FX

PNQX3257ZA TC0311YK0 (A)

FX-2/3