

Welcome aboard your vehicle

This Owner's Manual contains the information necessary:

- for you to familiarise yourself with your vehicle, to use it to its best advantage and to benefit fully from all the functions and the technical developments it incorporates.
- to ensure that it always gives the best performance by following the simple, but comprehensive advice concerning regular maintenance.
- to enable you to deal quickly with minor faults not requiring specialist attention.

It is well worth taking a few minutes to read this manual to familiarise yourself with the information and guidelines it contains about the vehicle and its functions and new features. If certain points are still unclear, our Network technicians will be only too pleased to provide you with any additional information.

The following symbol will help you when reading this manual:



To indicate a hazard, danger or safety recommendation.

The descriptions of the models given in this manual are based on the technical specifications at the time of writing. **This manual covers all items of equipment** (both standard and optional) **available for these models, but whether or not these are fitted to the vehicle depends on the version, options selected and the country where the vehicle is sold.**

This manual may also contain information about items of equipment to be introduced later in the model year.

Throughout the manual, the “approved dealer” is your RENAULT dealer.

Enjoy driving your new vehicle.

Translated from English. Copying or translation, in part or in full, is forbidden unless prior written permission has been obtained from the vehicle manufacturer.

C O N T E N T S

Sections

Getting to know your vehicle

1

Driving

2

Your comfort

3

Maintenance

4

Practical advice

5

Technical specifications

6

Alphabetical index

7

Radio

8

Section 1: Getting to know your vehicle

Keys, radio frequency remote control: general information	1.2
Locking and unlocking the doors	1.4
Opening and closing the doors	1.5
Engine Immobiliser	1.8
Front seats	1.9
Seat belts	1.8
Safety systems in addition to the seat belts	1.12
Child safety	1.14
Driving Position - Right Hand Drive	1.21
Warning lights	1.23
On-board computer	1.26
Exterior lighting and signals	1.28
Headlight height adjustment	1.29
Audible and visual signals	1.30
Mirrors	1.31
Screen washer/wiper	1.32
Fuel tank (filling with fuel)	1.33

KEYS, RADIO FREQUENCY REMOTE CONTROL: general information(1/2)

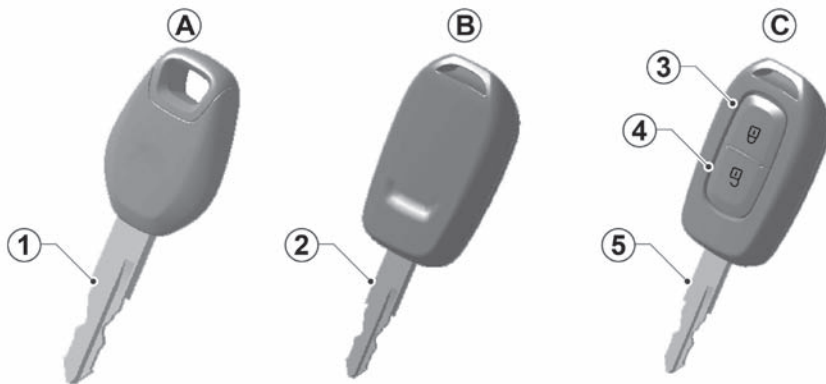

39531

Key A

1 Mechanical Key

Key B

2 Coded key for ignition switch.

Radio frequency remote control C

- 3 Locks all doors
- 4 Unlocks all doors
- 5 Coded key for ignition switch



Driver's responsibility:
Never leave your vehicle with the keys inside when leaving a child (or animal) in the car, even for a short period. The reason for this is that the child may endanger himself or others by starting the engine, activating equipment such as the window winders for example, or locking the doors.

The key must not be used for any function other than those described in the handbook (removing the cap from a bottle, etc.).

Advice : Avoid leaving the remote control in hot, cold or humid areas.

KEYS, RADIO FREQUENCY REMOTE CONTROL: general information(2/2)

The remote control unit operating range

This varies according to the environment. It is therefore important when handling the remote control to ensure that you do not lock or unlock the vehicle by inadvertently pressing the buttons.

Interference

The presence of certain objects (metal objects, mobile telephones, or an area with strong electromagnetic radiation, etc.) close to the key may create interference and affect the operation of the system.

Replacement and additional keys or remote controls

If you lose your remote control key or require another, you can obtain one from an approved dealer.

If a remote control or key is replaced, it will be necessary to take the vehicle **and all of its remote control keys** to an authorised dealer to reset them.

You may use up to four remote control keys per vehicle.

LOCKING AND UNLOCKING THE DOORS

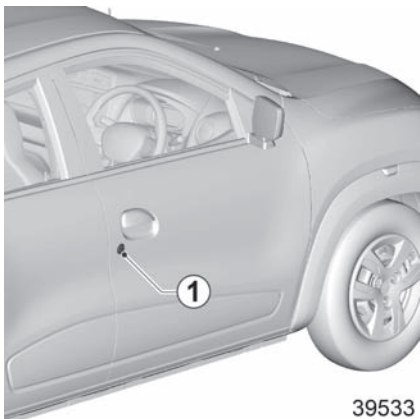

39533

Manual control

From the outside

Unlock the driver door using the key in door lock **1**.



Driver's responsibility

Never leave an animal, child or adult who is not self-sufficient alone on your vehicle, even for a short time. They may pose a risk to themselves or to others by starting the engine, activating equipment.

RISK OF DEATH OR SERIOUS INJURY.



39534

From the inside

Push in button **2** to lock and lift button **2** to unlock. It is impossible to open the door if **2** is pushed in.

Electric central locking

If equipped, It simultaneously locks or unlocks the doors.

Lock or unlock the doors by pressing switch **3**.

While locking the doors with remote, indicator lights will blink twice to confirm the locking. They will blink only once while unlocking the doors.



39534

Locking the doors without the radio frequency remote control

For example, in the event of a discharged battery or the radio frequency remote control temporarily not working.

With engine switched off and any door open, press and hold the switch **3 for more than five seconds.** When the door is closed, all the doors will be locked.

The vehicle can only be locked from the outside using the radio frequency remote control.

OPENING AND CLOSING THE DOORS(1/2)

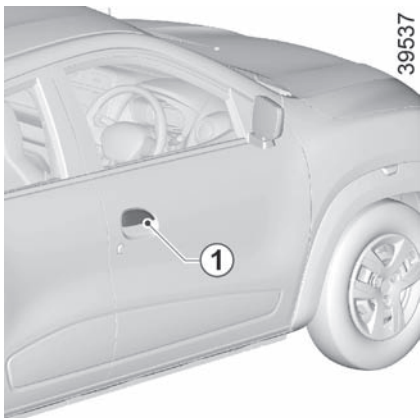

Opening the doors from the outside

With the doors unlocked (refer to the information on “Locking/unlocking the doors” in Section 1), place your hand on the handle **1** and pull towards you.

Special note

Depending on the vehicle, accessories (e.g. radio) stop working either when the engine is switched off or when the doors are locked.

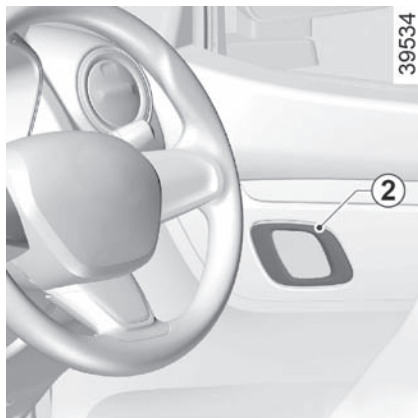

Opening from the inside

Pull handle **2**.



As a safety precaution, the doors should only be opened or closed when the vehicle is stationary.

OPENING AND CLOSING THE DOORS(2/2)

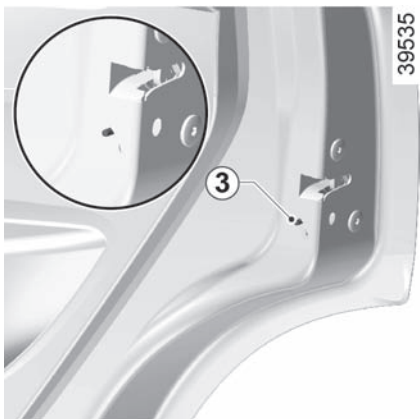

Child safety

If equipped, this feature is to make it impossible for the rear doors to be opened from the inside, move lever 3 on each rear door and check from the inside that the doors are securely locked.



Driver's responsibility when parking or stopping the vehicle

Never leave an animal, child or adult who is not self-sufficient alone on your vehicle, even for a short time.

They may pose a risk to themselves or to others by starting the engine, activating equipment such as the electric windows or by locking the doors.

Also, in hot and/or sunny weather, please remember that the temperature inside the passenger compartment increases very quickly.

RISK OF DEATH OR SERIOUS INJURY.

ENGINE IMMOBILISER

(Depends on vehicle)

Engine Immobiliser prevents the vehicle being driven by anyone not in possession of the vehicle's coded ignition key.

Operating principle

The vehicle is automatically protected a few seconds after the ignition is switched off.

If the vehicle does not recognise the coded ignition key or wrong key is used, the engine cannot be started.

System operation

When the ignition is switched on, the vehicle has recognised the code. You can then start the engine.

Vehicle protection

The vehicle will only be protected after the ignition has been switched off.

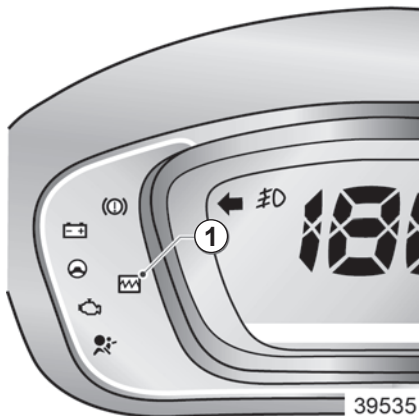

Operating faults

After the ignition has been switched on, if warning light **1** continues to flash or remains continuously lit, there is a system operating fault.

In all cases, it is essential to contact an approved dealer as only they are qualified to repair the engine immobiliser.

If the coded ignition key is faulty, use the second key (supplied with the vehicle).



Any unauthorised work carried out on the engine immobiliser (computers, wiring, etc.) could be dangerous. Work must be carried out by qualified personnel.



Driver's responsibility when parking or stopping the vehicle

Never leave an animal, child or adult who is not self-sufficient alone on your vehicle, even for a short time.

They may pose a risk to themselves or to others by starting the engine, activating equipment such as the electric windows or by locking the doors.

Also, in hot and/or sunny weather, please remember that the temperature inside the passenger compartment increases very quickly.

RISK OF DEATH OR SERIOUS INJURY.

FRONT SEATS

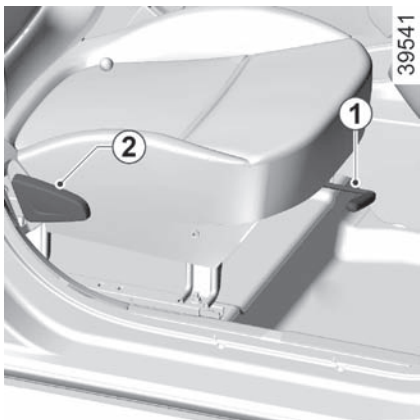

Move forward or backward

Lift the lever **1** to release and move the seat forward or backward. Release the lever **1** in desired position of seat and ensure that the seat is fully locked into place.

To tilt the seatback

Lift knob **2** upward to unlock recliner mechanism. Tilt the seat back to desired position and release knob. Ensure seat back is locked properly after release.



For safety reasons, carry out any adjustments when the vehicle is not being driven.

We would advise you not to recline the seatbacks too far to ensure that the effectiveness of the seat belts is not reduced. Nothing should be placed on the floor (area in front of driver) as such objects may slide under the pedal during braking manoeuvres, thus obstructing its use.

SEAT BELTS (1/3)



Adjusting the seat belts

Sit with your back firmly against the seatback.

The shoulder strap **1** should be as close as possible to the base of the neck but not on it.

Lap belt **2** must be worn flat over the thighs and against the pelvis. The seat belt must be worn as close to the body as possible. i.e.: avoid wearing heavy clothing or keeping bulky objects under the belts, etc.

Before starting, first adjust your driving position, then ask all occupants to adjust their seat belts to ensure optimum protection.

Adjusting your driving position (depending on the vehicle)

- **Sit well back in your seat** (having removed your coat or jacket etc.). This is essential to ensure your back is positioned correctly;
- **adjust the distance between the seat and the pedals.** Your seat should be as far back as possible while still allowing you to depress the clutch pedal fully. The seatback should be adjusted so that your arms are slightly bent when you hold the steering wheel.



- Ensure that no objects are placed in the area around the seat belt latch as they could prevent it from being properly secured.
- Make sure the seat belt latch is properly positioned (it should not be hidden away, crushed or flattened by people or objects).

Always wear your seat belt when travelling in your vehicle. You must also comply with the legislation of the particular country you are in.

Make sure that the rear bench seat is locked in correct position so that the rear seat belts will operate efficiently. Refer to the information on the Seats in Section 1.



Incorrectly adjusted or twisted seat belts may cause injuries in the event of an accident.

Use one seat belt per person, whether child or adult. Even pregnant women should wear a seat belt. In this case, ensure that the lap belt is not exerting too much pressure on the abdomen, but do not allow any slack.

SEAT BELTS (2/3)



To fasten

Unwind the belt **slowly and smoothly** and ensure that buckle **3** locks into latch **5** (check that it is locked by pulling on buckle **3**).

If the belt jams, allow it to return slightly before attempting to unwind it again.

If your seat belt is completely jammed, pull slowly, but firmly, so that just over 3 cm unwinds. Allow it to return slightly before attempting to unwind it again.

If there is still a problem, contact an approved dealer.



Unlocking

Press the button **4** on latch **5** and the seat belt will be rewound by the inertia reel. Hold by the buckle to make this easier.



– No modification may be made to the component parts of the originally fitted restraint system: seat belts, seats and their mountings. For special operations (e.g. fitting child seats), contact an authorised dealer.

- Do not use devices which allow any slack in the belts (e.g. clothes pegs, clips, etc.): a seat belt which is worn too loosely may cause injury in the event of an accident.
- Never wear the shoulder strap under your arm or behind your back.
- Never use the same belt for more than one person and never hold a baby or child on your lap with your seat belt around them.
- The belt should never be twisted.
- Following an accident, have the seat belts checked and replaced if necessary. Always replace your seat belts as soon as they show any signs of wear.
- Make sure that the buckle is inserted into the appropriate latch.

SEAT BELTS (3/3)



Adjusting the rear seat belts

Follow the same instructions of front seat belts to adjust/fasten/unlocking the rear seat belts.

Adjust the seat belt strap as indicated in the image for height adjustment.

SAFETY SYSTEMS IN ADDITION TO THE SEAT BELTS (1/2)



Depending on the vehicle, they are composed of :

- seat belt locking ;
- front airbag for driver **1**.

These systems are designed to act independently or together when the vehicle is subjected to a frontal impact.

Depending on the severity of the impact, the system can trigger :

- seat belt locking;
- airbag



- Have the entire restraint system checked following an accident.
- No operation whatsoever is permitted on any part of the system (air bags, electronic control units, wiring) and the system components must not be reused on any other vehicle, even if identical.
- To avoid premature triggering of the system which may cause injury, only qualified Network personnel are authorised to work on the methods of restraint in addition to the front seat belt.
- The electric trigger system may only be tested by a specially trained technician using special equipment.
- When the vehicle is scrapped, contact an approved dealer for disposal of the pretensioner and airbag gas generators.



Warnings concerning the driver's air bag

- Do not modify the steering wheel or the steering wheel boss.
- Do not cover the steering wheel boss under any circumstances.
- Do not attach any objects (badge, logo, clock, telephone holder, etc.) to the steering wheel boss.
- You must not remove the steering wheel (such work must only be performed by trained personnel from our Network).
- When driving, do not sit too close to the steering wheel. Sit with your arms slightly bent (see the information on “Adjusting your driving position” in Section 1). This will allow sufficient space for the air bag to inflate properly and be fully effective.
- Always use seat belts for a better and effective use of the Airbag.

SAFETY SYSTEMS IN ADDITION TO THE SEAT BELTS (2/2)



Driver's air bag 1

It is fitted on the driver's side on the steering wheel.

The airbag is of best use when it is used along with the seat belt.

Air bag system consists of :

- an airbag and gas generator fitted on the steering wheel for the driver ;
- an electronic unit for system monitoring which controls the gas generator electrical trigger system ;
- a single warning light  ;
- sensors.

Operation

This system is only operational when the ignition is switched on.

If a severe frontal impact occurs, the air bag inflates rapidly, cushioning the impact of the driver's head and chest against the steering wheel. The air bag then deflates immediately so that the driver is not impeded in any way when they get out of the vehicle.



The air bag system uses pyrotechnic principles. This explains why, when the air bag inflates, it will generate heat, produce smoke (this does not mean that a fire is about to start) and make a noise upon detonation. An air bag may inflate immediately, causing some minor, superficial grazing to the skin or other discomfort.

CHILD SAFETY: general information (1/2)

Carrying children

Children, and adults, must be correctly seated and strapped in for all journeys. The children being carried in your vehicle are your responsibility.

A child is not a miniature adult. Children are at risk of specific injuries as their muscles and bones have not yet finished growing. The seat belt alone would not provide suitable protection. Use an approved child seat and ensure you use it correctly.

CHILD RESTRAINT SEAT provision is given in Rear Left seat belt.



To prevent the doors being opened, use the childproof locks (refer to the information on “Locking/unlocking the doors” in Section 1).



A collision at 50 km/h is the same as falling a distance of 10 metres. Transporting a child without a restraint is the equivalent of allowing him or her to play on a fourthfloor balcony without railings.

Never travel with a child held in your arms. In the event of an accident, you will not be able to keep hold of the child, even if you yourself are wearing a seat belt.

If your vehicle has been involved in a road accident, replace the child seat and have the seat belts and fittings checked.

It is recommended that children and infants are seated in child restraint. You choose a child restraint that fits your vehicle. Always follow the manufacturer's instruction for installation and use. In addition there are many types of child restraint available for larger children that should be used for maximum protection.

CHILD SAFETY: general information (2/2)

Using a child seat

The level of protection offered by the child seat depends on ability to restrain child and on its installation. Incorrect installation risks the protection of the child in the event of harsh braking or an impact.

Before purchasing a child seat, check that it complies with the regulations and that it can be fitted in your vehicle. Consult an approved dealer to find out which seats are recommended for your vehicle. Before fitting a child seat, read the manual and respect its instructions. If you experience any difficulties during installation, contact the manufacturer of the equipment. Keep the instructions with the seat.

Set a good example by always fastening your seat belt and teaching your child:

- to strap themselves in correctly;
- to always get in and out of the car at the kerb, away from busy traffic.

Do not use a second-hand child seat or one without an instruction manual.

Check that there are no objects in the vicinity of the child seat which could impede its operation.



Never leave a child unattended in the vehicle. Check that your child is always strapped in and that the belt or safety harness used is correctly set and adjusted. Avoid wearing bulky clothing which could cause the belts to slacken.

Never let your child put their head or arms out of the window.

Check that the child is in the correct position for the entire journey, especially if asleep.

CHILD SAFETY: fitting a child seat (1/5)

Some seats are not suitable for fitting child seats. The diagram on the following page shows you how to attach a child seat.

The types of child seats indicated may not be available. Before using a different child seat, check with the manufacturer that it can be fitted.



Fit the child seat in rear seat Left Side.

Check that when installing the child seat in the vehicle it is not at risk of coming loose from its base.

If you have to remove the headrest, check that it is correctly stored so that it does not come loose under harsh braking or impact.

Always attach the child seat to the vehicle even if it is not in use so that it does not come loose under harsh braking or impact.

In the front seat

The laws concerning children travelling in the front passenger seat differ in every country. Consult the legislation in force and follow the indications on the diagram on the following page.

Before fitting a child seat in this seat (if authorised):

- deactivate the front passenger air bag;
- lower the seat belt as far as possible;
- move the seat as far back as possible;
- gently tilt the seatback away from vertical (approximately 25°);
- on equipped vehicles, raise the seat base as far as possible.

Do not change these settings after the child seat is installed.



RISK OF DEATH OR SERIOUS INJURY:

before fitting a rear-facing child seat in this seat, check that the air bag has been deactivated (refer to the information on “Deactivating the front passenger air bags” in Section 1).

CHILD SAFETY: fitting a child seat (2/5)

In the rear side seat

A carrycot can be installed across the vehicle and will take up at least two seats. Position the child with his or her feet nearest the door.

Before fitting a child seat to the ISOFIX anchorages on the rear side seat, ensure that the seat belt buckles are not positioned between the two ISOFIX anchorages on this seat. If necessary, move the buckle from the seat in question towards the centre of the vehicle.

Move the front seat as far forward as possible to install a rear-facing child seat, then move back the seat in front as far as it will go, although without allowing it to come into contact with the child seat.

For the safety of the child in the forward-facing seat, do not move the seat in front back past the middle of the runner, do not tilt the seatback too far (maximum of 25°) and raise the seat as much as possible.



Ensure that the child seat or the child's feet do not prevent the front seat from locking correctly.

Refer to the information on the "Front seats" in Section 1.

CHILD SAFETY: fitting a child seat (3/5)

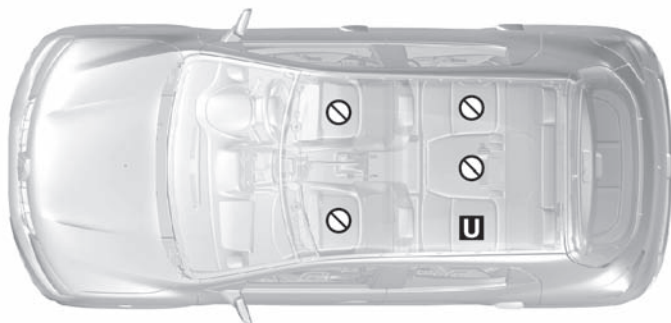

39660

Child seat attached using the belt

U Seat which allows a child seat with “Universal” approval to be attached by a seat belt.

⊘ Seat not suitable for fitting child seats.



RISK OF DEATH OR SERIOUS INJURY:

before fitting a rear-facing child seat on the front passenger seat, check that the airbag has been deactivated (please refer to the information on “Child safety: front passenger airbag deactivation, activation” in Section 1)



Using a child safety system which is not approved for this vehicle will not correctly protect the baby or child.

They risk serious or even fatal injury.

CHILD SAFETY: fitting a child seat (4/5)

The table below summarises the information already shown in the diagram on the following pages, to ensure the applicable regulations are respected.

Seating Position							
Mass Group	Weight of the child	Front passenger seat	Rear Outboard		Rear Centre	Intermediate Board	Intermediate Centre
			LEFT	RIGHT			
Group 0	Upto 10 kg	X	U	X	X	X	X
Group 0+	Upto 13 kg	X	U	X	X	X	X
Group I	9 to 18 kg	X	U	X	X	X	X
Group II	15 kg to 25 kg	X	U	X	X	X	X
Group III	22 kg to 36 kg	X	U	X	X	X	X



(1) RISK OF DEATH OR SERIOUS INJURY: never fit a child seat on the front seat if the vehicle has a passenger airbag which cannot be deactivated.

(2) RISK OF DEATH OR SERIOUS INJURY: before fitting a rear-facing child seat on the front passenger seat, check that the airbag has been deactivated (please refer to the information on “Child safety: front passenger airbag deactivation, activation” in Section 1).

CHILD SAFETY: fitting a child seat (5/5)

Refer to the “Child safety equipment” booklet available from the network to choose the seat suited to your child and recommended for your vehicle.

X = Seat not suitable for fitting child seats.

U = Seat which allows a child seat with “Universal” approval to be installed using a seat belt; check that it can be fitted.

DRIVING POSITION, RIGHT-HAND DRIVE (1/2)

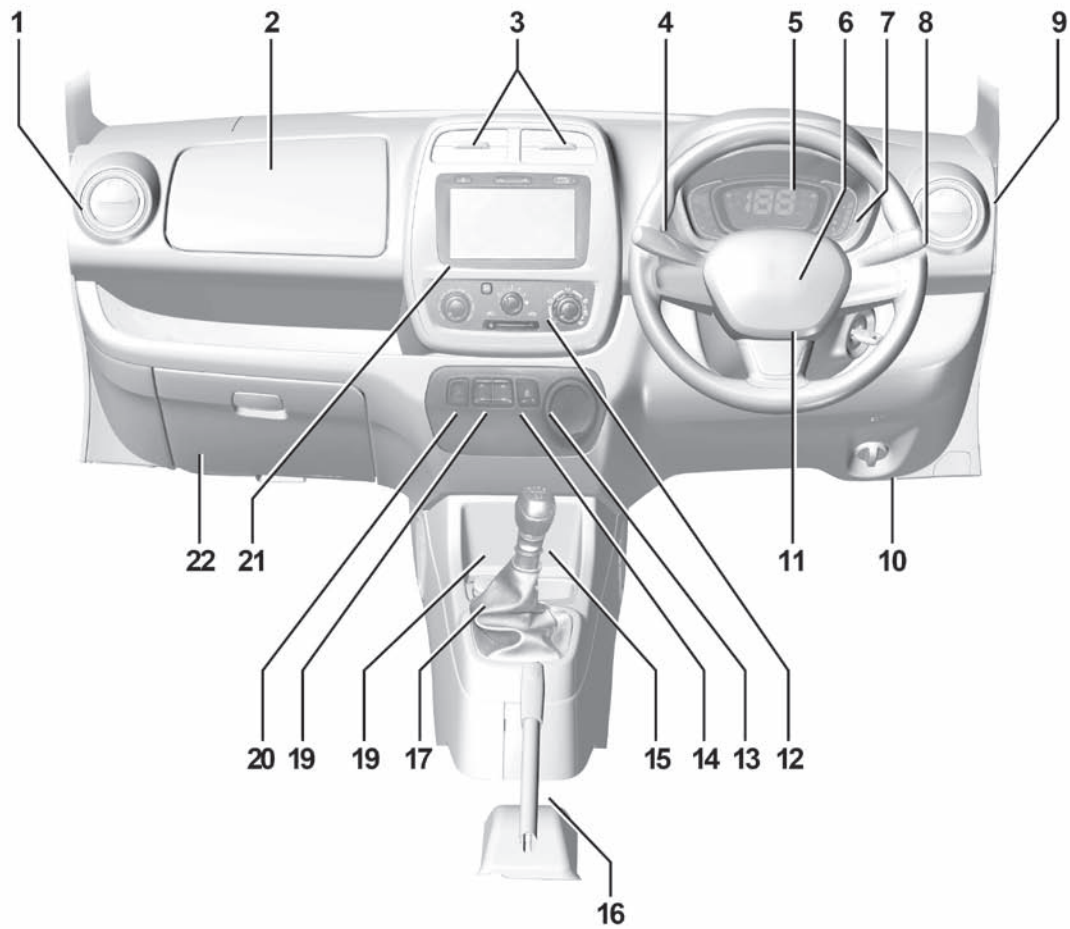

DRIVING POSITION, RIGHT-HAND DRIVE (2/2)

The presence of the equipment **DEPENDS ON THE VEHICLE VERSION AND COUNTRY.**

- | | | |
|---|---|---|
| <ul style="list-style-type: none">1 Side air vent.2 Upper Glove Box3 Centre air vents.4 Steering column stalk for windscreen wash/wiper.5 Instrument panel.6 Location for driver's airbag.7 Trip switch8 Stalk<ul style="list-style-type: none">– direction indicator lights,– exterior lights,– front fog lights, | <ul style="list-style-type: none">9 Side air vent.10 Beam height adjustment control.11 Horn12 Heating and ventilation controls.13 Electric central locking switch.14 Electric power window control(driver side).15 Gear lever. | <ul style="list-style-type: none">16 Handbrake.17 Cigarette lighter or accessories socket.18 Location for ashtray or cup holder.19 Electric power window control (passenger side).20 Hazard warning lights switch.21 Location for radio/ Navigation System22 Lower Glove Box |
|---|---|---|

WARNING LIGHTS (1/3)

The presence and operation of the warning lights **DEPEND ON THE EQUIPMENT AND COUNTRY.**



Instrument panel A



If no lights or sounds are apparent, this indicates a fault in the instrument panel. This indicates that it is essential to stop immediately (as soon as traffic conditions allow). Ensure that the vehicle is correctly immobilised and contact an approved Dealer.



Main beam headlight tell-tale light



Dipped beam headlight tell-tale



Front fog light tell-tale light*



Left-hand direction indicator tell-tale



Right-hand direction indicator tell-tale



Gear Shift Indicator

This symbol advises you to change to a higher gear (up arrow) or to a lower gear (down arrow) in order to help you to reduce the fuel consumption.

Orange warning light  comes on while you are driving, **drive carefully** to an authorised dealer as soon as possible. Failure to follow this recommendation risks damaging your vehicle.



The red warning light



requires you to stop immediately, for your own safety, as soon as traffic conditions allow. Switch off the engine and do not restart it. Contact an Authorised Dealer.

WARNING LIGHTS (2/3)

The presence and operation of the warning lights **DEPEND ON THE EQUIPMENT AND COUNTRY.**



Handbrake “on” warning light and brake circuit incident warning light

This comes on when the ignition is switched on and goes out when parking brake is dis-engaged. If it comes on during braking and is accompanied by a beep, it indicates that fluid level in circuit is low. It may be dangerous to continue driving. Contact approved dealer.



Battery charge warning light

If it comes on when you are driving, it indicates that the circuit has discharged. Consult an approved Dealer as soon as possible.



Warning light malfunction (red or orange)

Warning light (orange)

This lights up when the ignition is switched on and goes out as soon as the engine is started. It may come on in conjunction with other warning lights on the instrument panel. It means you should **drive very carefully** to an authorised dealer as soon as possible. If you fail to follow this recommendation, you risk damaging your vehicle.

Urgent stop warning light (red)

This lights up when the ignition is switched on and goes out as soon as the engine is started. It lights up at the same time as other warning lights, and is accompanied by a beep. It requires you to stop immediately, for your own safety, as soon as traffic conditions allow. Switch off the engine and do not restart it. Contact an approved Dealer.

WARNING LIGHTS (3/3)

The presence and operation of the warning lights **DEPEND ON THE EQUIPMENT AND COUNTRY.**



Coolant temperature and Oil Pressure Warning Light

It comes on when the ignition is switched on and then goes out. If this remains lit/comes ON while driving, accompanied by a continuous beep, this means the engine is overheating/engine oil is low. It is essential to stop the vehicle. Allow the engine to cool at idle speed for a minute or two. The temperature should drop. If not, stop the engine. Let it cool down before checking the coolant level. Check the oil level (refer to “Engine oil level: general information” in Section 4). If the level is normal, the light has come on for another reason: Consult an approved dealer straight away.



Warning light for monitoring exhaust gas

It comes on when the ignition is switched on and then goes out.

- If it lights up continuously, consult an approved dealer as soon as possible;
- If it flashes, reduce the engine speed until the light stops flashing. Contact your approved Dealer as soon as possible.

Refer to the information on “Advice: antipollution, fuel economy, driving” in Section 2.

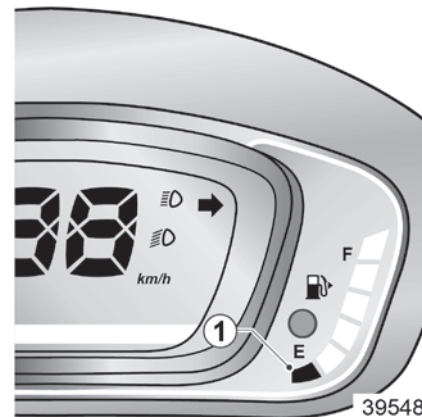

Fuel gauge warning light

The number of bars lit shows the fuel level. When all the bars disappear and only red bar **1** is lit, we advise you to visit the nearest fuel outlet. Once the fuel gauge light starts blinking accompanied by a beep sound, fill with fuel immediately, as the vehicle can stop anytime.

ON-BOARD COMPUTER (1/2)



Display selection key **1**

On-board computer **2**

The display depends on the vehicle and the country.

Scroll through the following information by pressing the button **1**

- a) Total mileage recorder ;
- b) Trip mileage recorder ;
- c) Fuel Used in Litre (from last reset) ;

- d) Average Fuel Consumption (from last reset) ;
- e) Current Fuel Consumption ;
- f) Estimated Fuel range (DTE - distance to empty) ;
- g) Distance travelled from Last reset ;
- h) Average speed from the Last Reset ;

Resetting the trip mileage

To reset the trip mileage recorder, the display must show the Tripmeter function.

Press and hold button **1**.

Interpreting some of the values displayed after resetting

The values showing average fuel consumption, range and average speed will become more stable and reliable the further you travel after pressing the reset button.

For the first few kilometres after pressing the reset key you will notice that the range increases as you travel. This range takes into account the average fuel consumption since the last time the reset button was pressed.

Refer to the table on the following pages showing display examples.





The current fuel consumption may decrease when:

- the vehicle stops accelerating;
- the engine reaches its operating temperature (if the engine was cold when the reset key was pressed);
- when driving from an urban area onto the open road.

Resetting is automatic when the maximum capacity of any of the memories is exceeded.

ON-BOARD COMPUTER (2/2)

The display of information shown below **DEPENDS ON THE VEHICLE EQUIPMENT AND COUNTRY.**

DISPLAY	Interpreting the display selected
999 km	Total mileage recorder
999 km	Trip mileage recorder
999.9 km	Fuel used (since the last time the reset button was pressed)
29.9 km/L 	Average fuel consumption (since the last time the reset button was pressed) This value is displayed after driving 400 metres. This takes into account the distance travelled and the fuel used since the last time the reset button was pressed.
29.9 km/L 	Current fuel consumption
999.9 km 	Estimated range with remaining fuel
99.9 km 	Distance travelled (since the last time the reset button was pressed)
099.9 km/h 	Average speed (since the last time the reset button was pressed)

EXTERIOR LIGHTING AND SIGNALS

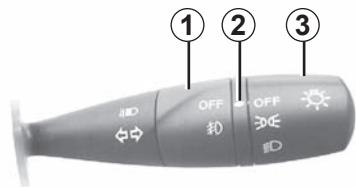

39559

Side lights

Turn the end of stalk **3** until the symbol is opposite mark **2**.

Dipped beam headlight

Depending on the vehicle, turn the end of stalk **3** down until the symbol is opposite mark **2**.

Main beam headlights

With the dipped beam headlights lit, push stalk **3**. The indicator on instrument panel comes on. To return to dipped headlight, pull the stalk **3** upward.

Switching off the lights

Turn the end of stalk **3** until the symbol is opposite mark **2**.

Front fog light- ON/OFF

Turn centre ring **1** on stalk until the symbol faces mark **2**. The fog lights only light up if exterior lights have been switched on. An indicator light on instrument panel then lights up. The corresponding indicator light goes out on instrument panel when the fog lights are switched off or the exterior lights are switched off.

Headlight flasher : Pull stalk **3** towards you to flash the headlights.

HEADLIGHT HEIGHT ADJUSTMENT

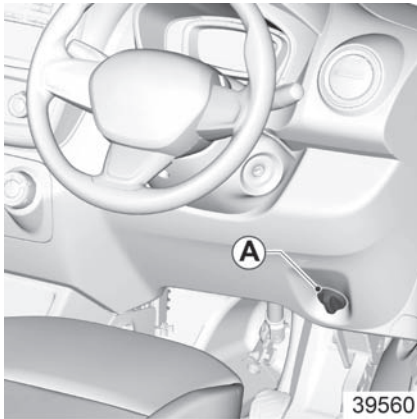

Headlight height Adjustment:

Knob **A** is used to adjust height of the headlight beam according to load. Turn control **A** anticlockwise to lower the beams and clockwise to raise them.

	Position
Only Driver	Zero
Driver + front passenger	Zero
Driver + Trunk	o
Driver + All passengers	oo
Driver + All passengers+Trunk	ooo

AUDIBLE AND VISUAL SIGNALS



Horn

Press on the centre or sides of the highlighted (horn pad) to use the horn.

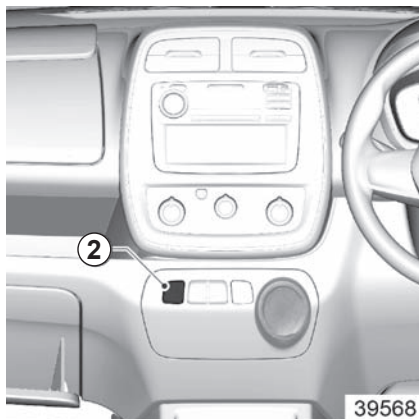

Hazard warning lights

Press switch **2**.

This switch activates all four direction indicators and the side indicator lights simultaneously.

It must only be used in an emergency to warn drivers of other vehicles that you have had to stop in an area where stopping is prohibited or unexpected, or that you are obliged to drive under special conditions.



Direction indicators

Move stalk **3** parallel to the steering wheel and in the direction you are going to turn it.

When driving on motorway, the steering is not usually turned sufficiently to enable the stalk to return automatically to home position. There is intermediate position where the stalk will not be held for lane change indication and there will be 3 blinks of indicator lights in dedicated direction.

If it does not return back automatically, release the stalk manually and it will return to its home position.

MIRRORS



Door mirrors with manual adjustment 1

Fold the door mirror 1 manually against the door window.



Interior rear view mirror 2

The interior rear-view mirror 2 is manually adjustable. When driving at night, tilt the mirror to avoid being dazzled by the headlights of the vehicle behind.



Objects observed in the door mirror glass are actually closer than they appear. For your safety, take this into account in order to correctly assess the distance before any manoeuvre.



For safety reasons, carry out any adjustments when the vehicle is not being driven.

WINDSCREEN WASHING / WIPING



Windscreen Wiper

With the ignition on, move the stalk **1** around the steering wheel (depending on the version):

- A** One time Mist Removal Function.
- B** Park.
- C** Intermittent wiping (depends on vehicle version) - The wiper will pause for several seconds between sweeps.
- D** Normal wiping speed.
- E** Fast wiping speed.



Windscreen Washing

With the ignition on, pull stalk **1** towards you (depending on the version).

A brief pull will trigger a single sweep of the wiper, in addition to the windscreen washer.

A longer pull will trigger multiple sweeps until the release of stalk **1** in addition to the windscreen washer. Once the stalk is released, there will be three sweeps of the wiping and one additional sweep after a few seconds.

In frosty weather, make sure that the wiper blade is not stuck by ice (risk of motor overheating).



When working in the engine compartment, ensure that the windscreen wiper stalk **1** is in the **B** position (park). Risk of injury.

Keep an eye on the condition of the blade. They should be replaced as soon as they become less efficient. This will occur approximately once a year. Clean your windscreen regularly.

If you switch off the ignition before switching off the windscreen wiper (position **A**) the blade will stop at random on the windscreen.

After switching the ignition back on, simply move stalk **1** to position **A** to place them in the park position.



Before any action on the windscreen (washing the vehicle, de-icing, cleaning the windscreen, etc.), return stalk **1** to position **B** (park).

Risk of injury and/or damage.

FUEL TANK (1/2)



Opening the Fuel Flap

- Stop the Engine ;
- Pull up the fuel filler door release lever **1** located on the floor, right front side of driver's seat which unlocks the Fuel Flap **A** ;
- Turn the fuel filler cap **B** counterclockwise slowly and completely unscrew the cap ;
- Remove the cap ;



Do not wash the filler area with a high-pressure washer.

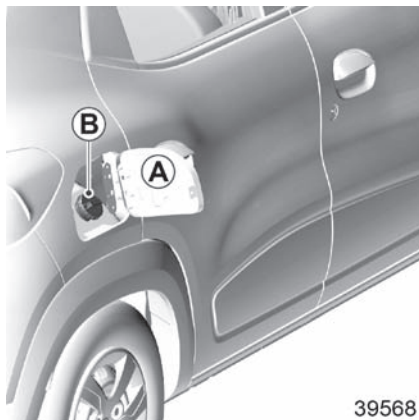

- After refueling, replace cap. Turn it clockwise and screw completely ;
- Push the fuel filler door closed until it latches.

NOTE: In cold weather, if the fuel filler door does not open, tap the door lightly. Then try to open it again.

Make sure that no water enters the fuel tank during filling.

Fuel filler cap: this is specific to the vehicle type. If you have to replace it, make sure the new cap is of the same type. Contact an approved dealer.

It is **essential** to use unleaded petrol. Using leaded petrol will damage the antipollution system and may lead to a loss of warranty.

FUEL TANK (2/2)

Filling up with fuel

With the ignition off, insert the nozzle **fully** before turning it on to fill the fuel tank (risk of splashing).

Keep the nozzle in this position throughout the entire filling operation.

When the pump cuts out automatically at the end of the filling procedure, a maximum of two further filling attempts may be made, as there must be sufficient space in the fuel tank to allow for expansion.



– Never place the cap near a source of heat or flame.

– Do not add any additives to the fuel, you risk damaging the engine.

If you notice a persistent fuel odour you should:

- stop the vehicle as soon as traffic conditions allow and switch off the ignition;
- switch on the hazard warning lights and ask your passengers to leave the vehicle and stay clear of the traffic;
- contact an approved Dealer.

Section 2: Driving

(Advice on use relating to fuel economy and the environment)

Running in, Ignition switch.	2.2
Starting / Stopping the engine.	2.3
Gear lever, Hand brake	2.5
Advice : antipollution, fuel economy and driving	2.7
Sequential gearbox	2.10
	2.1

RUNNING IN, IGNITION SWITCH

Running in

For the first **1,000 km**, do not exceed 80 km/h in the highest gear.

You may only expect top performance from your vehicle after approximately **3,000 kms**

Oil change frequency: Please refer to your vehicle's maintenance schedule.

NOTE : During the running in period, do not accelerate hard while the engine is still cold and do not let the engine over-rev.

Service intervals: refer to the Maintenance Schedule for your vehicle.



Stop and steering lock position St

To lock: remove the key and turn the steering wheel until the steering column locks.

To unlock: turn the key and the steering wheel slightly.

Accessories position A

When the ignition is switched off, any accessories (radio, etc.) will continue to function.

Ignition on position M

The ignition is switched on:
– the engine may be started.

Start position D

If the engine fails to start at the first attempt, turn the key back to home position before activating the starter again.

Release the key as soon as the engine starts.

STARTING/STOPPING THE ENGINE

Starting the engine

In cold condition: switch on the ignition for several seconds **before** starting the engine, so that it is easier to start the engine,

Petrol injection

- Activate the starter **without depressing the accelerator**.
- Release the key as soon as the engine starts.



Never leave your vehicle with the key or remote control inside and never leave a child (or a pet) unsupervised, even for a short while.

The reason for this is that the child may endanger himself or others by starting the engine, activating equipment such as the window winders for example, or locking the doors.

Risk of serious injury.

Never switch off the ignition before the vehicle has stopped completely. Once the engine has stopped, the brake servo, power assisted steering and passive safety equipment such as air bags will no longer operate.

The steering is locked when the key is removed.

Special note

Depending on the vehicle, accessories (e.g. radio) stop working either when the engine is switched off or when the doors are locked.

STARTING/STOPPING THE ENGINE

Starting problems

To avoid damage, **do not keep** trying to start the engine (by pushing or towing the vehicle) **without having identified and corrected the cause of the fault.**

If the fault cannot be identified, do not continue to try and start the engine, but contact an approved dealer.

The following operating conditions should be avoided:

- driving for long periods when the low fuel level warning light is lit;
- using leaded petrol;
- using fuel or lubrication additives which are not approved.

Operating faults such as:

- faulty ignition, running out of fuel or disconnected spark plugs resulting in the engine misfiring or cutting out when driving;
- loss of power,

may cause overheating, reducing efficiency **which may irreparably damage vehicle components and also the vehicle.**

If you notice any of the above operating faults, have the necessary repairs carried out as soon as possible by an approved dealer.

These faults may be avoided by regularly taking your vehicle to an approved Dealer at the intervals specified in the Maintenance Schedule.



Do not park the vehicle or run the engine in locations where combustible substances or materials such as grass or leaves can come into contact with the hot exhaust system.

GEAR LEVER, HAND BRAKE (1/2)



39572

Selecting reverse gear (vehicle in stationary condition)

Vehicles with manual gearbox: refer to the grid on the gear lever knob **1**.

Pull the release knob in upward direction and then engage the reverse gear.

Gear change indicators

Depending on the vehicle, to obtain optimum consumption levels, an indicator light on the instrument panel lets you know the best time to move up or down a gear.



Depending on the gradient and/or vehicle load, it may be necessary when stationary to apply the brake by at least a further two notches and engage a gear (1st or reverse gear).



An impact to the underside of the vehicle while manoeuvring (e.g.: striking a post, raised kerb or other street furniture) may result in damage to the vehicle (e.g.: deformation of an axle). To prevent any risk of accident, have your vehicle checked by an approved dealer.

GEAR LEVER, HAND BRAKE (2/2)

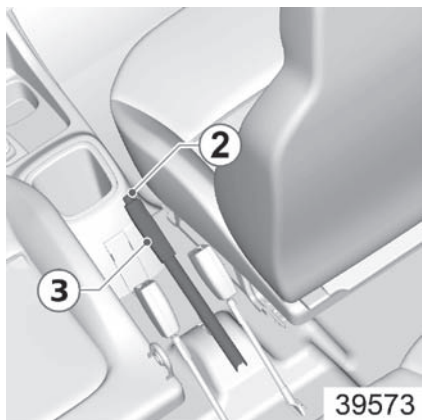

Handbrake

To release

Pull lever **3** up slightly, press button **2** and then lower the lever to the floor.

The red warning light on the instrument panel will come on and a sound if you are driving with an incorrectly released handbrake.

To apply

Pull lever **3** upwards and make sure the vehicle is immobilised.



Make sure that the handbrake is properly released when driving (red indicator light off), otherwise overheating, or even damage, may occur.



Depending on the gradient and/or vehicle load, it may be necessary when stationary to apply the brake by at least a further two notches and engage a gear (1st or reverse gear).

ADVICE: antipollution, fuel economy and driving (1/3)

Your vehicle has been designed with respect for the **environment** in mind for its entire service life.

By virtue of its design, moderate fuel consumption and initial settings, your vehicle also conforms to current antipollution regulations. The manufacturer is actively striving to reduce pollutant exhaust gas emissions and to save energy. But the fuel consumption of your vehicle and the level of pollutant exhaust gas emissions are also your responsibility. Ensure that it is maintained and used correctly.

Maintenance

It should be noted that failure to respect antipollution regulations may lead to legal action being taken against the vehicle owner. In addition, replacing engine, fuel supply system and exhaust components with parts other than those originally recommended by the manufacturer may alter your vehicle so that it no longer complies with antipollution regulations.

Have your vehicle adjusted and checked by an authorised dealer, in accordance with the instructions given in your Owner's Manual: they will have all the equipment necessary for ensuring that your vehicle is maintained to its original standard.

Aiding fuel economy

Depending on the vehicle, in order to optimise consumption, an indicator light on the instrument panel will inform you of the best moment to upshift or downshift gears:

shift up a gear  ;

shift down a gear  .

Engine adjustments

- **ignition:** this does not require adjustment.
- **spark plugs:** for optimum fuel economy, efficiency & performance the specification laid down in Owner's Manual must be strictly applied.

If the spark plugs have to be changed, contact an approved dealer for this.

- **idle speed:** this does not require adjustment.
- **air filter, oil filter:** a choked element hinders performance. It must be replaced as per the maintenance schedule.

Emissions

Your vehicle has been designed to emit fewer greenhouse gases (CO₂) while in use.

ADVICE: antipollution, fuel economy and driving (2/3)



Driving

- Drive carefully for the first few kilometres until the engine reaches its normal operating temperature, rather than let it warm up while the vehicle is stationary.
- Speed is expensive. Sporty driving uses a lot of fuel: drive with a light foot.
- Study the road ahead so that you are able to brake as little as possible, it can be sufficient just to lift off the accelerator.

- Avoid sudden acceleration.
- Do not overrev the engine in the intermediate gears. Always use the highest gear possible without labouring the engine.

Make your own contribution towards protecting the environment

- Worn parts replaced in the course of routine vehicle maintenance (vehicle battery, oil filter, air filter, batteries, etc.) and oil containers (empty or filled with used oil) must be disposed of through authorised Renault Dealer
- In all cases, comply with local legislation.

ADVICE: antipollution, fuel economy and driving (3/3)

Exhaust gas monitoring system

This system detects operating faults in the vehicle's antipollution system. These faults may cause mechanical damage or release of harmful substances.



This warning light on the instrument panel indicates if there are any faults in the system:

This comes on when the ignition is switched on and goes out after three seconds.

- If it comes on continuously, consult an approved dealer. If it flashes, reduce the engine speed until the light stops flashing. Contact an approved dealer as soon as possible.
- Do not try to maintain the same speed up a hill, accelerate no more than you would on the level. Keep your foot in the same position on the accelerator pedal.

- Poor weather conditions, flooded roads. Do not drive through water if it is higher than the lower edge of the wheel rim.
- Avoid using the vehicle for door-to-door journeys (short journeys, with long stops in-between) because in these conditions, the engine never reaches its ideal temperature.

Tyres

Increased fuel consumption could be the result of:

- insufficient pressure,
- using non-recommended tyres.

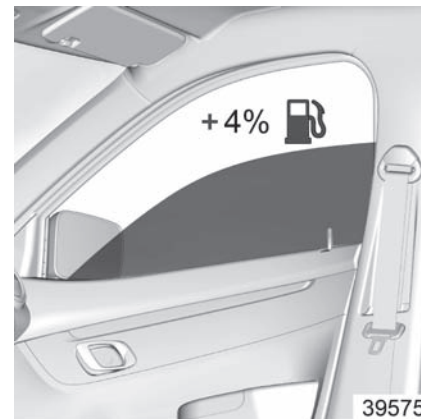

Advice on use

- Electricity is fuel; switch off all the electrical components which are not really needed.

However (safety first), keep your lights on when the visibility is bad ("see and be seen").

- Driving with the windows open at around 100 km/h will increase fuel consumption by approximately 4%.

AUTOMATED MANUAL TRANSMISSION (1/4)



Gear Rotary Shifter 1

This allows you to engage forward gear, reverse and neutral.

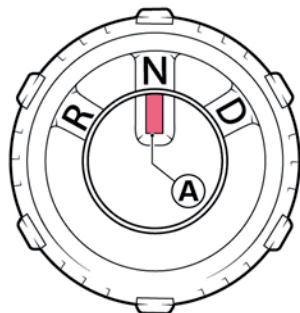

Gear shift pattern

Align the letters R/N/D to the red pointer.

A where R/N/D stands for:

D Drive mode

N Neutral

R Reverse mode

NOTE:

- The red pointer is fixed.
- R/N/D is rotating switch.

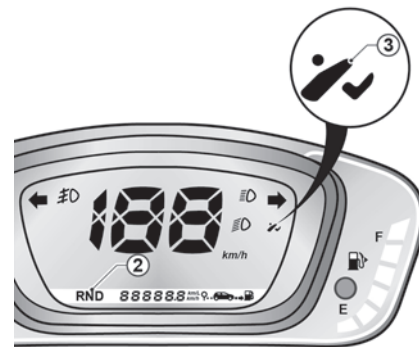

Display

The engaged gear (R/N/D) is indicated on the instrument panel display **2**.

In case, gear is not engaged properly, letter R or D will blink on the cluster.

If RN/ND blinks together, this indicates that rotary shifter is not in proper position. Driver advised to shift accordingly.

3 -Brake pedal press warning light.



For safety reasons, do not switch off the ignition before the vehicle has come to a complete standstill.

AUTOMATED MANUAL TRANSMISSION (2/4)



Similar to a vehicle equipped with a manual gearbox, this vehicle is also not able to prevent itself from rolling on a slope if the hand-brake is not applied or the brake pedal not pressed continuously in “N” mode.

The vehicle should always be towed in Ignition OFF condition with neutral position.

In cold weather start the engine and wait for a few seconds before rotating the gear rotary shifter from N to D/R position to prevent engine stalling.

NOTE

Once the vehicle is switched to ignition ON position, the gearbox initializes. This produces a light sound. This is normal. Crank the engine after 3 seconds.

Starting the engine

Switch ON ignition. To start engine, keep the key in ignition and wait for 3 seconds to initiate starting sequence.

When starting the engine, always place the rotary knob in “N” position and depress the brake pedal firmly. The engine cannot be started unless the rotary knob is in “N” position and brake pedal is depressed. Do not press accelerator pedal while starting the engine.

Starting off on an uphill/downhill

- Apply parking brake so that vehicle will not move.
- Shift the rotary gear knob to “D” while depressing the brake pedal. Make sure that gear position indicator displays “D” in cluster.
- Release the brake pedal and depress the accelerator gradually. Once the vehicle starts to move, release the parking brake and continue to depress accelerator to start off.

Creeping

It is a function that enables the vehicle to move very slowly without depressing the accelerator pedal. Follow steps as:

- Start the engine as instructed in “Starting the engine” section.
- With the foot on brake pedal, shift the rotary knob to “D” and ensure “D” glows in cluster permanently.
- Release the parking brake and brake pedal to activate creeping.

NOTE

Brake pedal warning light glows if brake pedal is not pressed when,

- Starting the engine.
- Engine ON and rotary knob shifted from “N” to R/D.
- Ignition is ON and engine is OFF, rotary knob shifted from “N” to R/D.
- Driver door is open and R/D is engaged.

AUTOMATED MANUAL TRANSMISSION (3/4)

Driving in automatic mode

When ignition is switched ON, start the vehicle in neutral “N” with brake pedal pressed, rotate the gear shifter to D to engage drive mode.

The letter D appears on the display. The vehicle is controlled using the accelerator and the brake. Gears will change automatically at the optimal moment.

Automatic mode takes account of:

- The position and speed of depression of the accelerator pedal to assess driving style and select the optimal gear.
- The position and speed of depression of the brake to commence engine braking in preparation for a downshift.
- If the gear does not engage to R/D even the rotary knob is shifted, system shifts automatically after sometime and creates some noise from gears. This does not indicate any malfunction.

However, if the system does not shift automatically, shift gear knob to “N” and again shift to R/D in brake pedal pressed condition. R/D indicator and brake pedal indicator will flash on the cluster if the rotary knob shifted to R/D from “N” without depressing brake pedal.

Reverse gear

With the brake pedal pressed, rotate the gear shifter to R. The letter R displays on the cluster. Release the brake pedal slowly to allow vehicle to move in reverse direction. Press the accelerator pedal gently to increase the speed.

– The engine idle speed (creep function) is sufficient for parking manoeuvres.

To drive, shift the gear from “R” to “D” by rotating the gear rotary lever once the vehicle is stationary. Press brake pedal to engage a gear when vehicle is stationary else, warning light will come on cluster.

When stopped at traffic lights, with the gear engaged in “D”, keep the vehicle stationary by continuously pressing the brake pedal without changing the gear shifter to neutral **N**.

The vehicle will begin moving again:

- Either slowly, if the brake is released without accelerating (e.g. when in a traffic jam).
- Or quickly, by releasing the brake and accelerating.

ACTIONS TO AVOID

1. Using accelerator pedal to keep the vehicle stationary on an uphill slope while shifting the gear to R/D will create a warning buzzer sound.
2. Shifting the rotary knob to R/D while depressing the accelerator.
3. Maintaining the vehicle stationary on an uphill slope using creeping function will create a warning buzzer sound.

AUTOMATED MANUAL TRANSMISSION (4/4)

Accelerating and overtaking

- Slowly depress the accelerator pedal to accelerate gradually.
- to obtain maximum vehicle performance, depress the accelerator pedal quickly and completely.
- the speed with which the accelerator pedal is depressed is directly related to the speed with which the vehicle automatically shifts to a lower gear to accelerate quickly.

Parking

- To park the vehicle, first bring the vehicle to stationary position.
- If the road is flat, then rotate the gear shifter to N and engage the handbrake and switch off the ignition to complete the parking manoeuvre.
 - On a slope, it is recommended to keep the gear shifter in R/D, engage the handbrake and switch off the ignition to complete the parking manoeuvre.

Precautions in Drive mode

- If the vehicle is kept stationary on a slope for too long without applying the brakes or handbrake, it will strain the system and there is a risk that the clutch will overheat.

In this case, an intermittent beeping sound will indicate that the brake pedal or hand brake needs to be applied.

- Never leave the vehicle with the engine running with gear engaged condition.
- A warning light related to brake application will appear on the cluster if brake/handbrake is not applied.
- If engine ON and the vehicle is stationary, it is recommended to keep the brake pedal in pressed condition.

Towing your automated manual transmission vehicle

If the gear is engaged in R/D,

- Switch on the ignition.
- Press brake pedal.
- Select neutral (N).
- Release Brake pedal.
- Check that gear engaged in “N” by ensuring permanent display of letter N in cluster.
- Turn OFF ignition.

If neutral is not engaged and no indication in cluster, must tow the vehicle with the front wheels raised.

Stopping the vehicle

The vehicle can be stopped by depressing the brake pedal regardless of gear position. This is because, clutch is automatically disengaged to prevent the engine from stopping.



Section 3: Your comfort

Air vents, air outlets	3.2
Heating, Ventilation, Air conditioning	3.4
Air conditioning: information and advice on use	3.6
Windows	3.7
Courtesy Light, Sun visor and Grab handle.	3.8
Passenger compartment storage and fittings	3.9
Rear seat.	3.10
Boot	3.11
Multimedia equipment	3.12

AIR VENTS, air outlets (1/2)

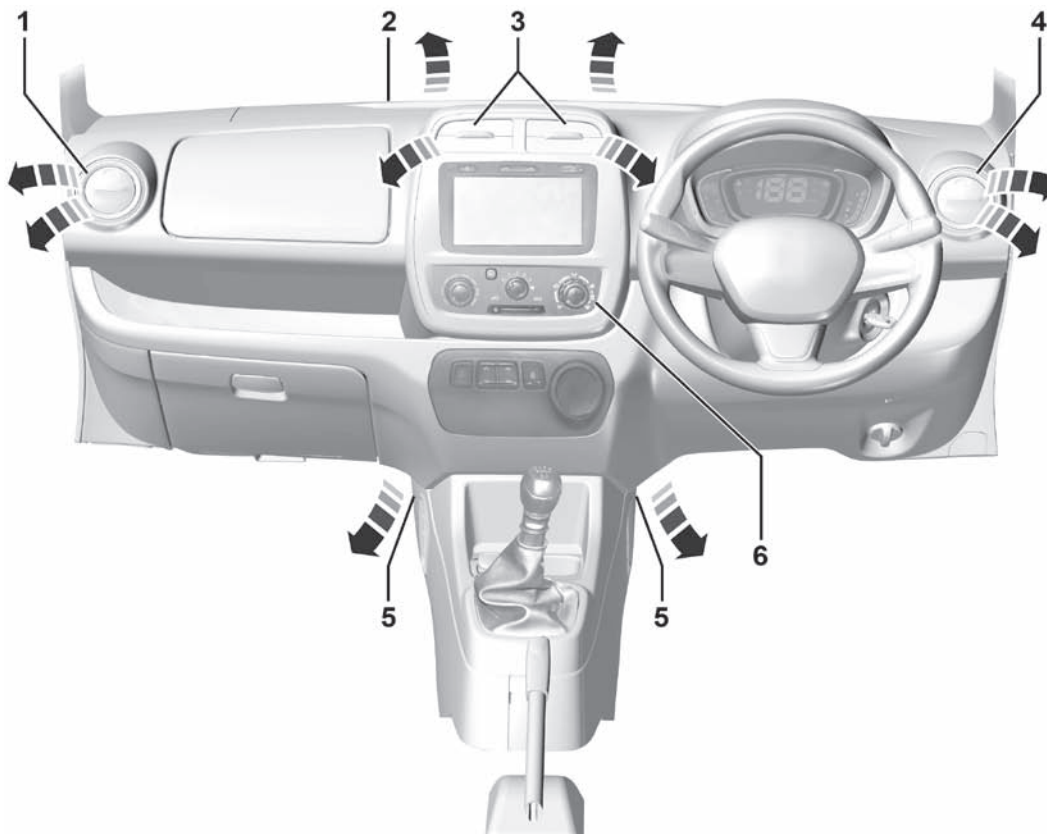

1 Left-hand side air vent

3 Centre air vents

5 Control panel

2 Windscreen demisting vents

4 Right-hand air vent

6 Front passenger's footwell heater outlets

AIR VENTS, air outlets (2/2)

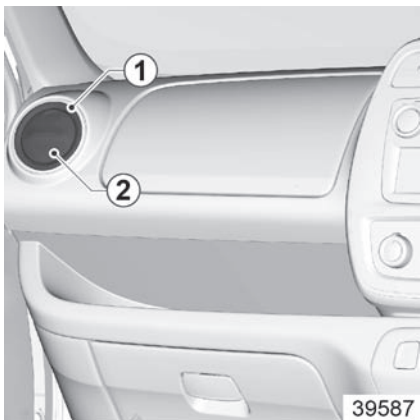

Air flow

Lateral Air vents (*Left and Right*)

To open, press on the air vent (point 1) until it is open as far as required.

To close, press on the air vent (point 2) until it is shut.

To change Air Flow direction, swivel the air vent to the desired position.



Centre Air Vents

(depends on the vehicle)

To open, press on the air vent, (point 3/4) until it is open as far as required.

To close, pull the cursor (3/4) towards the inside of the vehicle

To change direction, move the cursor away from centre of 3/4 (move laterally).



Do not add anything to the vehicle's ventilation circuit (for example, to remove bad odours).

There is a risk of damage or of fire.

HEATING, VENTILATION, AIR CONDITIONING (1/2)

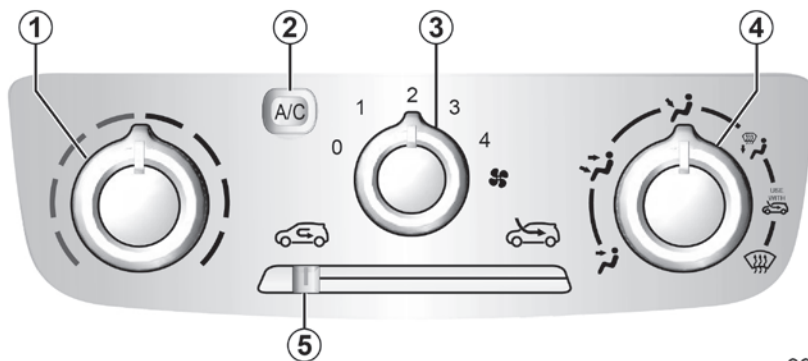

39589

Controls

The controls will depend on the vehicle equipment level.

- 1 Air temperature adjuster.
- 2 Switching air conditioning on or off.
- 3 Adjusting the ventilation fan speed.
- 4 Distribution of Air.
- 5 Switching passenger compartment to isolation mode / air recirculation mode.

Information and advice on use: refer to information on “Air conditioning: information and advice on use”.

Adjusting the air temperature

Turn control **1** to obtain the desired temperature. The further towards the red the slide is, the higher the temperature will be.

Adjusting the ventilation fan speed.

Turn control **3** from 0 to 4. The further to the right it is positioned, the more air is blown into the passenger compartment. If you want to shut off the flow of air completely and stop the system, set control **3** to 0.

The system is deactivated: the ventilation speed for the passenger compartment air is zero (vehicle stationary), you can however still feel a slight flow of air when the vehicle is moving.

Leaving this control in position 0 for prolonged periods can lead to condensation forming on the side windows and windscreen and problems due to the use of non-renewed air in the passenger compartment.

HEATING, VENTILATION, AIR CONDITIONING (2/2)

Switching passenger compartment isolation mode/ air recirculation mode on.

Bring lever **5** to position .

Under these conditions, air is taken from the passenger compartment and is recirculated, with no air being taken from outside the vehicle.

Air recirculation is used to:

- to isolate the passenger compartment from the external atmosphere
- to bring the passenger compartment to the desired temperature as quickly as possible.

Rapid demisting

Turn controls **1**, **3** and **4** to positions



- Turn control **1** on full hot position
- Turn control **3** on max speed position **4**
- Turn control **4** to full defrost mode.
- move slider knob **5** to fresh air mode.

Using the climate control increases the speed of demisting.

Information and advice on use: refer to information on “Air conditioning: information and advice on use”.

Prolonged use of air recirculation can lead to condensation forming on the windscreen, and discomfort due to the use of non-renewed air in the passenger compartment. You are therefore advised to pick-up external air as soon as the air recirculation function is no longer required, by sliding control **5** to the right.

AIR CONDITIONING: information and advice on use

Fuel consumption

You will normally notice an increase in fuel consumption (especially when driving in town) when the air conditioning is operating.

Advice for reducing consumption and helping to preserve the environment

Drive with the air vents open and the windows closed.

If the vehicle has been parked in the sun, open the doors for a few moments to let the hot air escape before starting the engine.

Maintenance

Refer to the Maintenance Document for your vehicle for the inspection frequency.

Operating faults

As a general rule, contact your approved dealer in the event of an operating fault.

- **Reduction in de-icing, demisting or air conditioning performance.**
Contact an approved Renault Dealer.
- **No cold air is being produced.**
Check that the controls are set correctly and that the fuses are sound. Otherwise, switch off the system.

Presence of water under the vehicle

After prolonged use of the air conditioning system, it is normal for water to be present under the vehicle. This is caused by condensation.



Do not open the refrigerant fluid circuit. The fluid may damage eyes or skin.

WINDOWS



Manual window winders

Depending on the version, turn handle **1** to lower or raise the window to the desired height.

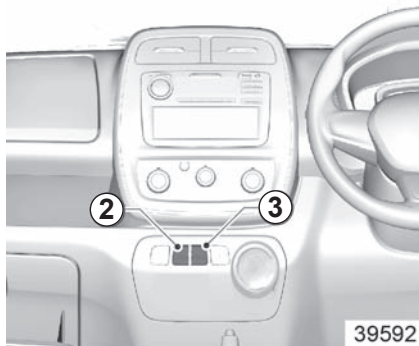

Electric window

Dashboard switches

Press the bottom of switch **2** or **3** to open the window or press the top of switch **2** or **3** to close it to the desired level.

2 for the passenger side.

3 for the front driver side.



Driver's responsibility

If a body part gets trapped, reverse the direction of travel of the window as soon as possible by pressing the relevant switch. Never leave your vehicle with the key inside and never leave a child (or a pet) unsupervised, even for a short while. They may pose a risk to themselves or to others by starting the engine, activating equipment such as the electric windows or by locking the doors.



Avoid resting any objects against a half-open window: there is a risk that the electric window could be damaged.

COURTESY LIGHT, SUN VISOR AND GRAB HANDLE

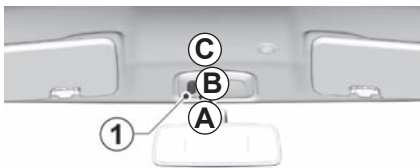

Courtesy light

This feature depends on the vehicle version.

- Press switch **1** to position **A** for switching **ON** the light.
- Press switch **1** to position **B** for auto - ON lighting, which activates when a door is opened and switches off when both the front doors have been closed correctly;
- Press switch **1** to position **C** for switching **OFF** the light.

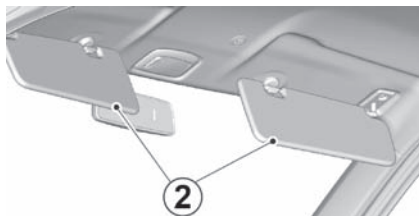

Front sun visor

This feature depends on the vehicle version.

Lower the sun visor **2** over the windscreen or unclip it and turn it over the side window.



Rear Grab handle 3

This feature depends on the vehicle version.

This offers support and can be held when the vehicle is being driven.

Do not use it for getting into or out of the vehicle.

PASSENGER COMPARTMENT STORAGE, FITTINGS

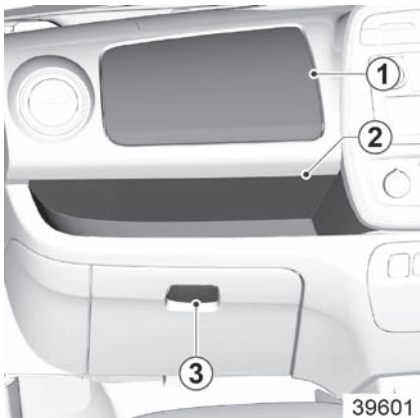

Upper Glove Box 1

Open Storage 2

Lower Glove box 3

.Need to press at the lowest center of the lid to open and close gently by pressing on the same point.

Pull handle 3 to open lower glove box.

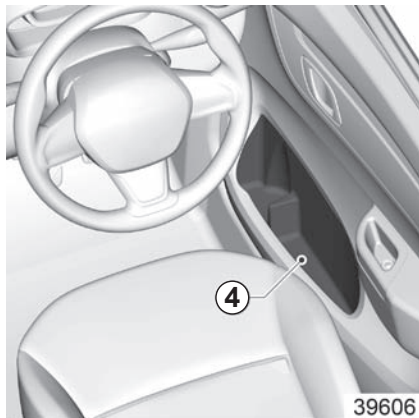

Door Storage Compartment 4

Cup Holder 5, 6



Ensure that no hard, heavy or pointed objects are placed in the "open" storage compartments in such a way that they may fall onto passengers during sudden turning, braking or in the event of an accident.

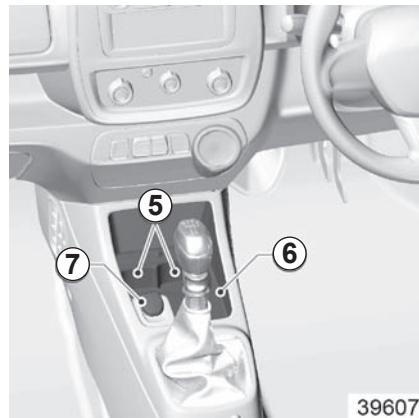

Accessories socket 7

They are provided for connecting accessories approved by our Technical Department.



Connect accessories with a maximum power of 120 watts (12 V) only.

When several accessory sockets are used at the same time, the total power of the connected accessories must not exceed 180 watts.

Fire hazard.

REAR SEATS

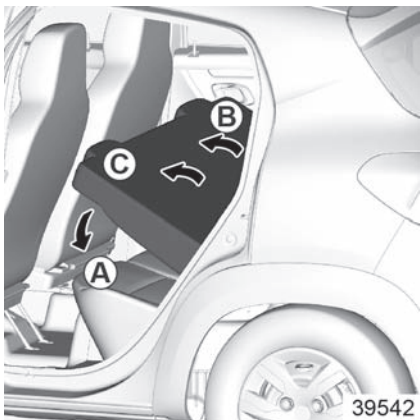

Fold the backrest

This feature depends on the vehicle version.

Store the seat belts in proper position.

Hold the straps **B** and **C** on both ends of seat and pull them upward and fold the backrest down till **A**.

To un-fold the seat back-rest

Lift up seat back and push to the upright position until it is latched on both sides.



When refitting the seat-back, make sure it is correctly locked in place.

If seat covers are fitted, make sure these do not prevent the seatback latch from locking in. Make sure that the seat belts are positioned correctly.

Check that the rear seat belts are positioned and operating correctly each time the rear seat is moved.

Never allow anyone to ride in the luggage area or on second row seat when it is in the fold-down position. Use of these areas by passengers without proper restraints could result in serious injury in an accident or sudden stop.

Properly secure all luggage to help prevent it from sliding or shifting. Do not place luggage higher than the backrest.

When operating the backrest, be careful not to scratch or damage seat belts.

BOOT



39609

To open

From the outside

Insert the key in the boot lock **1**, turn it and lift the boot lid.

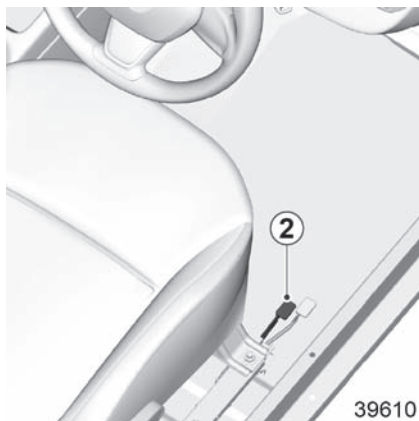

39610

From the inside

Pull the lever **2**, then lift the boot lid.



39611

To close

Lower the boot lid from point **3** using your hands and properly close it.

MULTIMEDIA EQUIPMENT



The presence and location of this equipment depends on the vehicle's version and multimedia equipment.

- 1 Radio or navigation system
- 2 Microphone.



Hands-free telephone integrated control

On equipped vehicles, use microphone 2

- In all cases, it is very important to follow the manufacturer's instructions carefully.
- The specifications of the brackets and wires (available from our network) vary depending on the equipment level of your vehicle and the type of radio. Consult your approved Dealer to find out the correct part number.
- No work may be carried out on the vehicle's electrical or radio circuits, except by approved Dealers: an incorrectly connected system may result in damage being caused to the electrical equipment and/or the components connected to it.

If your vehicle is not fitted with an audio system, one can be fitted and locations have been provided for the radio 1;

To install any equipment, please consult an authorised dealer.

Refer Multimedia manual for more details



Using the telephone

We remind you of the need to conform to the legislation in force concerning the use of such equipment.

To use this equipment, consult the instructions for the equipment which should be kept with the other vehicle documentation.

Section 4: Maintenance

Bonnet	4.2
Engine Oil - Topping up, filling	4.3
Levels :	4.6
Brake fluid	4.6
Windscreen washer	4.6
Engine coolant	4.7
Filters	4.7
Battery	4.8
Tyre pressure	4.10
Bodywork maintenance	4.11
Interior trim maintenance	4.13
	4.1

BONNET

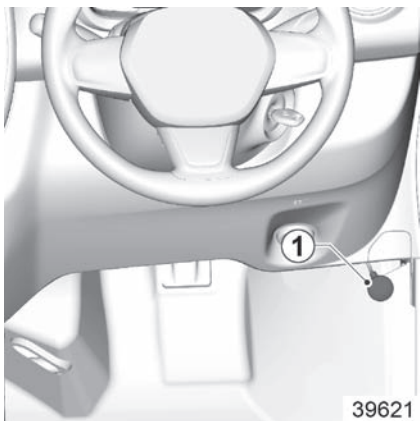

To open the bonnet, pull the knob **1**.

Unlocking the bonnet latch

To unlock, gently lift the bonnet and push tab **2** in the direction of arrow **A** to release the latch **3**.

Opening the bonnet

Lift the bonnet; remove the Hood-Stay rod from lock clip and place into the hole to hold the Hood open.



Do not press down on the bonnet: there is a risk that the bonnet may accidentally close.

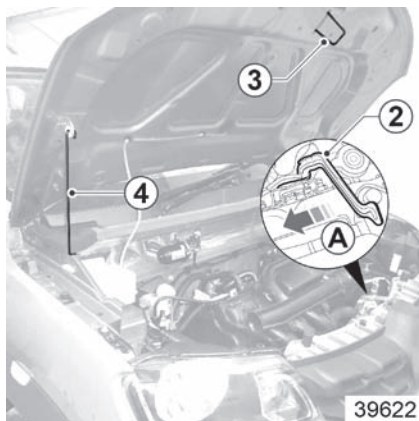

Closing the bonnet

To close the bonnet again, remove the Hood-Stay rod **4** from the hole and place to the lock clip; lower it to 30 cm above the closed position, then release it. It will latch automatically under its own weight.



The engine may be hot during operations in close proximity. In addition, the engine cooling fan may come on at any moment.

Risk of injury.



In the event of even a slight impact involving the radiator grille or bonnet, have the bonnet lock checked by an approved Dealer as soon as possible.



When working in the engine compartment, ensure that the windscreen wiper stalk is in the park position.

Risk of injury.



Ensure that the bonnet is properly locked. Ensure that nothing is preventing locking (grit, cloths, etc.).



Make sure nothing is left in the engine compartment (cloth, tools, etc.).

These may damage the engine or cause a fire.

ENGINE OIL LEVEL: topping up, filling (1/3)

It is normal for an engine to use oil for lubrication and cooling of moving parts and it is normal to top up the level between oil changes.

However, contact your approved Dealer if more than 0.5 litres is being consumed every 1,000 kms after the running in period.

Oil change frequency: check the oil level from time to time and certainly before any long journey to avoid the risk of damaging your engine.

In order to prevent splashback, it is recommended that a funnel be used when topping up/filling with oil.

Consult your approved dealer at once if you notice an abnormal or repeated drop in any of the fluid levels

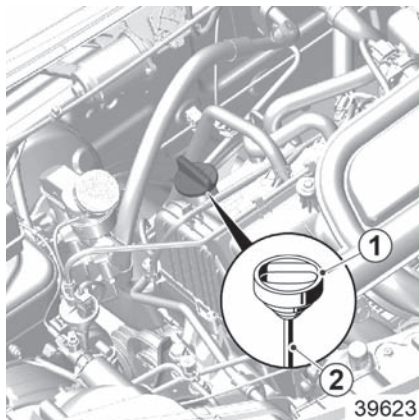

Reading the oil level

- Remove the dipstick and wipe with a clean, lint-free cloth;
- Guide the dipstick in as far as it will go (for vehicles equipped with a captype dipstick, screw the cap in as far as it will go);
- Take out the dipstick again;
- Read the level: it should never fall below minimum mark or exceed maximum mark.

Once the operation has been completed, ensure that the dipstick is guided in as far as it will go or that the “cap-type dipstick” is completely screwed in.



Exceeding the maximum engine oil level

Under no circumstances must the maximum fill level be exceeded: risk of damage to the engine and catalytic converter. If the oil level exceeds the maximum level, **do not start your vehicle** and contact an approved Dealer.



Before performing any action in the engine compartment, the ignition must be switched off by pressing the engine stop button (please see the information on “Starting, stopping the engine” in Section 2).

ENGINE OIL LEVEL: topping up, filling (2/3)

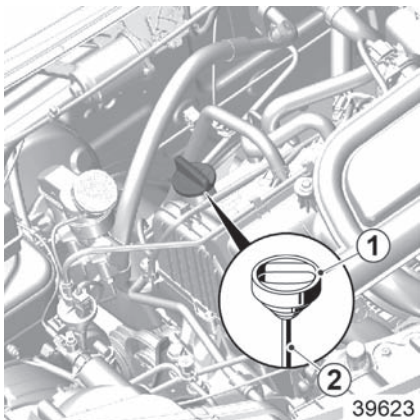

Topping up/Filling

The vehicle must be parked on level ground and the engine should be cold (for instance, before the engine is started up for the first time in the day).

Do not exceed the **max** level and do not forget to refit cap **1**.

- Unscrew cap **1**;
- top up the level (as a guide, the capacity between the minimum and maximum reading on the dipstick **2** is approximately 0.85 litres, (depending on the engine);
- wait for approximately 20 minutes to allow the oil to flow into the engine;
- check the level using the dipstick **2** (as described above).

Once the level has been read, ensure that the “cap-type dipstick” is completely screwed in.

In order to prevent splashback, it is recommended that a funnel be used when topping up/filling with oil.

Consult an approved dealer at once if you notice an abnormal or repeated drop in any of the fluid levels



Never run the engine in an enclosed space as exhaust gases are poisonous.



The engine may be hot during operations in close proximity. In addition, the engine cooling fan may come on at any moment.

Risk of injury.



Engine oil change: if you are changing the oil when the engine is hot, be careful not to scald yourself if the oil overflows.

ENGINE OIL LEVEL: topping up, filling (3/3)

Oil change

Service interval: refer to the Maintenance Document for your vehicle.

Oil change capacity

Please refer to the maintenance document for your vehicle, or contact an authorised dealer.

Always check the engine oil level using the dipstick, as explained previously (it should never fall below the minimum

Engine oil grade

Refer to the maintenance document for your vehicle.



Exceeding the maximum engine oil level

The oil level should only be read with the dipstick as explained above. If the oil level exceeds the maximum level, **do not start your vehicle** and contact an approved dealer.



Filling:

Take care when topping up the oil that no oil drips onto engine components.

RISK OF FIRE

Rememebr to re-fit the cap securely as there is a risk of fire if oil splashes onto hot engine components.

LEVELS (1/2)

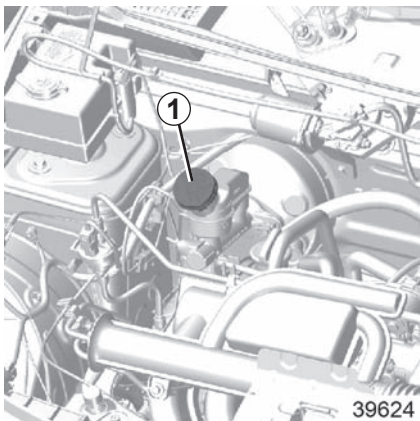

Brake fluid level

This should be checked frequently, and immediately if you notice even the slightest loss in braking efficiency. The level should be read with the engine switched off and on level ground.



The engine may be hot during operations in close proximity. In addition, the engine cooling fan can come on at any moment.

Risk of Burns and Injury.

Level 1

It is normal for the level to drop as the brake shoes become worn, but it must never drop lower than the “MIN” warning line shown on brake fluid reservoir.

If you wish to check the disc and drum wear yourself, you should obtain the document explaining the checking procedure from the approved dealer network or from the manufacturer's web site.

Topping Up

After any operation on the hydraulic circuit, a specialist must replace the fluid. Only use fluids approved by RENAULT and which have been taken from a sealed container.



Consult your approved dealer at once if you notice an abnormal or repeated drop in any of the fluid levels. No operations should be carried out on the cooling circuit when the engine is hot.

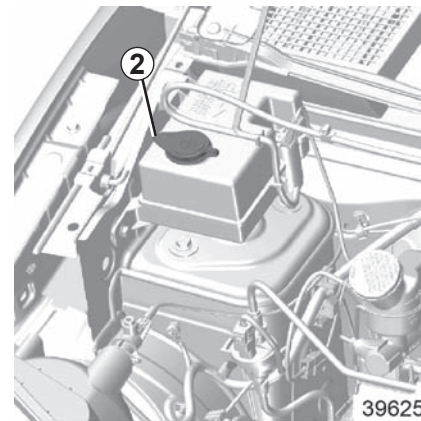

Windscreen washer

Topping up

With the engine switched off, open the cap. Fill **2** until you can see the fluid, then replace the cap.

Liquid: Special windscreen washer fluid (antifreeze product for winter).

Jets: Use a tool such as a needle to adjust the height of the windscreen washer jets.

LEVELS (2/2) / FILTERS

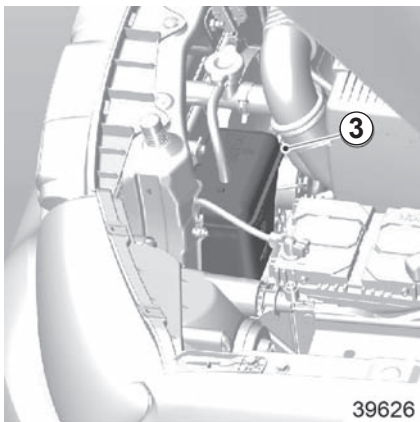

Coolant

With the engine switched off and on ground level, the level **when cold** must be between the MIN and MAX marks on reservoir **3**.

Top this level up **when cold** before it reaches the MIN mark.



No operations should be carried out on the cooling circuit when the engine is hot.

Risk of burns.

Checking intervals

Check the coolant level regularly (very severe damage is likely to be caused to the engine if it runs out of coolant).

If the level needs to be topped up, only use products approved by our Technical Department which ensure:

- protection against freezing;
- anti-corrosion protection of the cooling system.

Replacement intervals

Refer to the Maintenance Schedule for your vehicle.

Consult an approved dealer at once if you notice an abnormal or repeated drop in any of the fluid levels.

Filters

The replacement of filter elements (air filter, cabin filter, fuel filter, etc.) is scheduled in the maintenance operations for your vehicle.

Replacement intervals for filter elements: please refer to your vehicle's maintenance schedule.



The engine may be hot during operations in close proximity. In addition, the engine cooling fan may come on at any moment.

Risk of injury.

BATTERY (1/2)

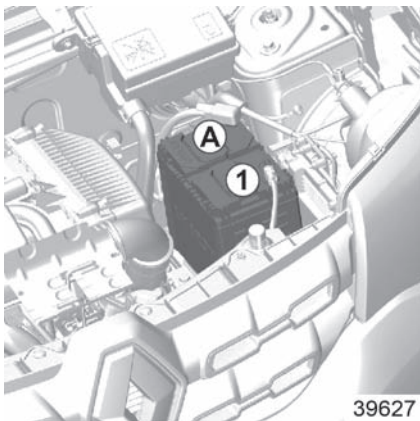

The battery **1** does not require any maintenance. **You must not open it or perform any added liquid.**



Handle the battery with care as it contains sulphuric acid, which must not come into contact with eyes or skin. If it does, wash the affected area with plenty of water and see a doctor if necessary.

Ensure that naked flames, red hot objects and sparks do not come into contact with the battery as there is a risk of explosion.

The charge status of your battery can decrease especially if you use your vehicle:

- for short journeys ;
- for driving in town ;
- when the temperature drops ;
- after extended use of consumers (radio etc.) with the engine switched off.

BATTERY (2/2)

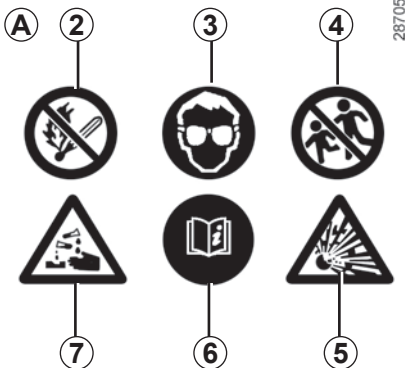

Label A

Observe the indications on the battery:

- 2 Naked flames and smoking are forbidden;
- 3 Eye protection required;
- 4 Keep away from children;
- 5 Explosive materials;
- 6 Refer to the handbook;
- 7 Corrosive materials.

Replacing the battery

As this operation is complex, we advise you to contact an approved Dealer.



The engine may be hot during operations in close proximity. In addition, the engine cooling fan may start at any moment.

Risk of injury.

TYRE PRESSURE

Adhere to the tyre pressures (including the emergency spare wheel). The tyre pressures should be checked at least once a month and additionally before any long journey.

Tyre pressures should always be checked when the tyres are cold, ignore higher pressures which may be reached in hot weather or following a fast journey.

If the tyre pressures cannot be checked when the tyres are cold, increase the pressures from 0.2 to 0.3 bar (or 3 PSI).

never deflate a hot tyre.

Refer the table for the Tyre Pressure in your vehicle.

A label of the tyre pressure details is pasted on the driver door of the vehicle.

Tyre Location	Un-Laden Condition	Laden Condition
Front	A	B
Rear	C	D
Spare Wheel	E	

A : un-laden condition for front tyre pressure ;

B : laden condition for front tyre pressure ;

C : un-laden condition for rear tyre pressure ;

D : laden condition for front tyre pressure ;

E : tyre pressure for spare wheel.

Special note concerning fully laden vehicles: the maximum speed must be limited to 100 kph.



Incorrect tyre pressures lead to abnormal tyre wear and unusually hot running.

These are factors which may affect safety and lead to poor road holding,

- risk of bursting or tread separation.
- The pressure depends on the load and the speed of use. Adjust the pressure according to the conditions of use.
- Please be aware that a poorly tightened or missing valve cap can make the tyres less airtight and lead to pressure loss. –
- Always use valve caps identical to those fitted originally and tighten them fully.

BODYWORK MAINTENANCE (1/2)

A well-maintained vehicle will last longer. It is therefore recommended to maintain the exterior of the vehicle regularly.

Your vehicle has been treated with very effective anti-corrosion products. It is nevertheless subject to various outside influences.

Corrosive agents in the atmosphere

- atmospheric pollution (built-up and industrial areas),
- saline atmospheres (near the sea, particularly in hot weather),
- seasonal and damp weather conditions (e.g. road salt in winter, water from road cleaners, etc.).

Minor impacts

Abrasive action

Dust and sand in the air, mud, road grit thrown up by other vehicles, etc.

You should take a number of minor precautions in order to safeguard your vehicle against such risks.

What you should not do

Do not degrease or clean mechanical components (e.g. the engine compartment), underneath the body, parts with hinges (e.g. inside the doors) and painted plastic external fittings (e.g. bumpers) using high-pressure cleaning equipment or by spraying on products not approved by our Technical Department. Doing this could give rise to corrosion or operational faults.

Wash the vehicle in bright sunlight or freezing temperatures.

Scrape off mud or dirt without pre-wetting.

Allow dirt to accumulate on the exterior.

Allow rust to form following minor impacts.

Use solvents not approved by our Technical Department to remove stains as this could damage the paintwork.

Drive in snow or muddy conditions without washing the vehicle, particularly under the wheel arches and body.

You should

Wash your car frequently, **with the engine off**, with cleaning products recommended by the manufacturer (never use abrasive products). Rinse thoroughly with a jet:

- spots of tree resin and industrial grime;
- mud in the wheel arches and underneath the body which forms damp patches;
- **bird droppings**, which cause a chemical reaction with the paint that **rapidly discolours paintwork and may even cause the paint to peel off**;
wash the vehicle **immediately** to remove these marks since it is impossible to remove them by polishing;
- salt, particularly in the wheel arches and underneath the body after driving in areas where the roads have been gritted.

Remove any plant matter (resin, leaves, etc.) from the vehicle regularly.

BODYWORK MAINTENANCE (2/2)

Respect local regulations about washing vehicles (e.g. do not wash your vehicle on a public highway).

Observe the vehicle stopping distances when driving on gravelled surfaces to prevent paint damage.

Repair, or have repaired quickly, areas where the paint has been damaged, to prevent corrosion spreading.

Remember to visit the body shop periodically in order to maintain your anti-corrosion warranty. Refer to the Maintenance Document.

If it is necessary to clean mechanical components, hinges, etc., spray them with products approved by our Technical Department to protect them after they have been cleaned.

We have selected special products to care for your vehicle and you can obtain these from the manufacturer's accessory outlets.

Vehicles with a matte paint finish

This type of paint requires certain precautions.

Do not do the following

- use wax-based products (polishing);
- rub hard;
- wash the vehicle in a roller-type car wash;
- wash the vehicle using a high-pressure device;
- attach stickers to the paintwork (risk of leaving marks).

You should do the following

Wash the vehicle by hand using plenty of water, using a soft cloth or a gentle sponge.

Using a roller type car wash

Return the windscreen wiper stalk to the Park position (refer to the information on the “Windscreen washer, wiper” in Section 1). Check the mounting of external accessories, additional lights and mirrors, and ensure that the wiper blades are secured with adhesive tape. Remove the radio aerial must if your vehicle is fitted with this equipment. Remember to remove the tape and refit the antenna after washing.

Cleaning the headlights

As the headlights are made of plastic “glass”, use a soft cloth or cotton wool to clean them. If this does not clean them properly, moisten the cloth with soapy water, then wipe clean with a soft damp cloth or cotton wool. Finally, carefully dry off with a soft dry cloth.

Cleaning products containing alcohol must not be used.

INTERIOR TRIM MAINTENANCE (1/2)

A well-maintained vehicle will last longer. It is therefore recommended to maintain the interior of the vehicle regularly.

A stain should always be dealt with swiftly.

Whatever type of stain is on the trim, use **cold** (or warm) **soapy water with natural soap**.

Detergents (washing-up liquid, powdered products, alcohol-based products) should not be used.

Use a soft cloth.

Rinse and soak up the excess.

Instrument panel

(e.g. instrument panel, clock, exterior temperature display, radio display, etc.)

Use a soft cloth (or cotton wool).

Caution:

No liquid cleaning agents and water should be used to clean the Instrument panel.

It is recommended to use only soft and dry cloth to clean the instrument panel as there is no glass screen on the same.

Cleaning products containing alcohol must not be used under any circumstances.

Seat belts

These must be kept clean.

Use products selected by our Technical Department (Approved outlets) or warm, soapy water and a sponge and wipe with a dry cloth.

Detergents or dyes must not be used under any circumstances.

Textiles (seats, door trim, etc)

Vacuum-clean the textiles **regularly**.

Liquid stain

Use soapy water.

Dab lightly (never rub) with a soft cloth, rinse and remove the excess.

Solid or semi-solid stain

Carefully remove the excess solid or pasty material **immediately** with a spatula (working from the edges to the centre to avoid spreading the stain). Clean in a similar way as a liquid stain.

Special instructions for sweets or chewing gum

Put an ice cube on the stain to solidify it, then proceed as for a solid stain.

For further recommendations for maintaining the interior, and/or for any unsatisfactory results, please see an authorised dealer.

INTERIOR TRIM MAINTENANCE (2/2)

Removal/replacing removable equipment originally fitted in the vehicle

If you need to remove equipment in order to clean the passenger compartment (for example, mats), always ensure that they are correctly refitted and they are at correct position. (The driver's mat should be fitted on the driver's side, etc.) and fit them with the components supplied with the equipment (for example, the driver mat should always be fixed using the pre-fitted mounting components).

With the vehicle stationary, ensure that nothing will impede driving (anything obstructing the pedals, heel wedged by the mat, etc.).

You should not:

You are strongly advised not to position objects such as deodorants, scents, etc. near air vents, as this could damage your dashboard trim.



You are strongly recommended not to use highpressure or spray cleaning equipment inside the passenger compartment: use of such equipment could impair the correct functioning of the electrical or electronic components in the vehicle, or have other detrimental effects.

Section 5: Practical advice

Puncture, emergency spare wheel	5.2
Wheel trim, tools	5.3
Changing a wheel	5.4
Tyres	5.6
Front lights-Changing headlamps main bulbs	5.9
Fuses	5.10
Radio frequency remote control: batteries.	5.13
Battery - Troubleshooting	5.14
Towing	5.16
Accessories	5.17
Operating faults	5.18

PUNCTURE, EMERGENCY SPARE

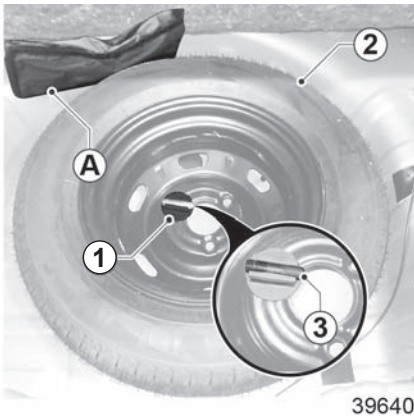

Spare Wheel

This is located in the luggage compartment.

To access it :

- Open the boot ;
- depending on the vehicle, remove the carpet ;
- Unscrew the sparewheel lock **1** ;
- remove emergency spare wheel **2** ;
- Stud **3**.
- Jack pouch **A**



If the vehicle is parked on the hard shoulder, you must warn other road users of your vehicle's presence with a warning triangle or with other devices as per the legislation applying to the country you are in.



Jack must be placed only in specific places provided for it. Placing jack against Rear Axle or Front Transversal Link is strictly prohibited.

NB: ensure that the emergency spare wheel or punctured wheel are correctly positioned. Check that the boot carpet is correctly positioned in its bump stops to prevent it from being damaged.



If spare wheel is stored for long, get it checked by Dealer to ensure that it is safe to use.

- Never fit more than one emergency spare wheel to the same vehicle.
- Replace the emergency spare wheel as soon as possible with the original one.

WHEEL TRIM, TOOLS



39636

Central wheel trim with visible wheel bolts (example: wheel trim 1)

Depending on the version, the bolts are directly accessible directly or after removing the wheel cap.

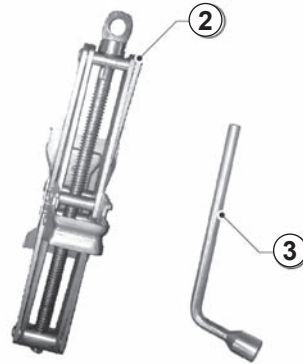

39641

Accessing the tools

Jack 2 and Wrench 3

Jack 2 is in a jack pouch and is placed on the left side of the spare wheel. To use the jack, take it out from pouch with care. While keeping it back, fold it up completely and replace it in the pouch.

The wrench 3 is placed along with warning triangle. Replace it in the same pouch after use.



Never leave tools unsecured in the vehicle: there is a risk that they may be thrown about during braking. After use, make sure the tools are correctly positioned in their housings: there is a risk of injury. The jack is designed for wheel changing purposes only. Under no circumstances should it be used for carrying out repairs underneath the vehicle or to gain access to the underside of the vehicle.

CHANGING A WHEEL (1/2)



Switch on the hazard warning lights. Keep the vehicle away from traffic and on a level surface where it will not slip (if necessary, place a solid support under the jack base). Apply the parking brake and engage a gear (first or reverse).

Ask all passengers to leave the vehicle and keep them away from traffic. If the vehicle is parked on the hard shoulder, you must warn other road users of your vehicle's presence with a warning triangle.



Removing the Wheel

Use the wheel wrench to loosen the wheel bolts by firmly holding the wrench and applying force to unscrew.

Remove completely one of the wheel bolts and screw-in the stud **A** (provided in spare wheel lock screw) in its place, this helps to locate wheel while refitting and retains position when all the wheel bolts are removed.



Place the jack under the body ,and align it to be in-between two locating markings. It is forbidden to lift the car by placing any jack under front control arms, rear axle and subframe.

Crank the jack using wheel wrench until the tyre raises up and sufficient

CHANGING A WHEEL (2/2)

Refitting the Carwheel

-by aligning one of holes to the stud in the wheel drum/disc

Keep the wheel cover (on select variants) and wheel bolts handy, place and hold the wheel cover to align with the stud and fasten the 2 wheel bolts in the remaining locations.

Ensure the wheel is fastened sufficient enough, so that removing stud will not cause the wheel to come out off the drum/disc.

Replace the stud by bolt and put the stud back in spare wheel lock screw cap by gently pressing it in the groove.

Using the wrench, tighten the bolts evenly. Uncrank (release) the jack using wheel wrench till the jack becomes free from holding the vehicle anymore.

Now tighten fully the wheel bolts.

Place the punctured or removed wheel in spare wheel storage area and lock it by provided lock screw.

Place the wheel wrench and jack in pouch.



If the vehicle is parked on the hard shoulder, you must warn other road users of your vehicle's presence with a warning triangle or with other devices as per the legislation applying to the country you are in.



If you have a puncture, replace the wheel as soon as possible. A tyre which has been punctured should always be inspected (and repaired, where possible) by a specialist."

TYRES (1/3)

The tyres are the only contact between the vehicle and the road, so it is essential to keep them in good condition. You must make sure that your tyres conform to local road traffic regulations.



For your safety, please respect the speed limit.

When they need to be replaced, only tyres of the same make, size, type and profile should be used on a single axle.

They must: either have a load capacity and a speed capacity at least equal to the original tyres, or correspond to those recommended by your authorised dealer.

Failure to heed these instructions could endanger your safety and affect your vehicle's roadworthiness.

Risk of loss of control of the vehicle.



31546

Maintaining the tyres

The tyres must be in good condition and the tread form must have sufficient depth; tyres approved by our Technical Department have tread wear indicators **1** which are **indicators moulded into the tread at several points**.

When the tread has worn down to the wear warning strips, **these strips will become visible 2**: it is then necessary to replace your tyres because the tread rubber is now **only 1.6 mm deep at most, resulting in poor road holding on wet roads**.

An overloaded vehicle, long journeys by motorway, particularly in very hot weather, or continual driving on poorly surfaced minor roads will lead to more rapid tyre wear and affect safety.



Incidents which occur when driving, such as striking the kerb, may damage the tyres and wheel rims, and could also lead to misalignment of the front or rear axle geometry. In this case, have the condition of these checked by an approved dealer.

TYRES (2/3)

Tyre pressures

Adhere to the tyre pressures (including the emergency spare wheel). The tyre pressures should be checked at least once a month and additionally before any long journey (refer to the label affixed to the edge of the driver's door).



Incorrect tyre pressures

lead to abnormal tyre wear and unusually hot running.

These are factors which may seriously affect safety and lead to:

- poor road holding,
- risk of bursting or tread separation.

The pressure depends on the load and the speed of use. Adjust the pressure according to the conditions of use (refer to the label affixed to the edge of the driver's door).

The pressures should be checked cold: ignore higher pressures which may be reached in hot weather or following a high speed journey.

If the tyre pressures cannot be checked when the tyres are **cold**, increase the pressures from **0.2 to 0.3 bar (or 3 PSI)**.

Never deflate a hot tyre.

Special note

Depending on the vehicle, there may be an adapter which needs to be positioned on the valve before air is added.



Please be aware that a poorly tightened or missing valve cap can make the tyres less airtight and lead to pressure loss.

Always use valve caps identical to those fitted originally and tighten them fully.

Emergency spare wheel

Refer to the information on “Changing a wheel” in Section 5.

Changing wheels around

This practice is not recommended.

TYRES (3/3)

Fitting new tyres



For safety reasons, this operation must be carried out by a specialist.

Fitting different tyres may change your vehicle as follows:

- it may mean that your vehicle no longer conforms to current regulations;
- it may change the way it handles when cornering;
- it may cause the steering to be heavy;
- It may affect the use of snow chains.



Changing a wheel

As the tyre pressure monitor may take several minutes to correctly determine the positions of the wheels and the pressure values after driving, check the tyre pressures following any operation.

Use in winter

Chains

For safety reasons, fitting snow chains to the rear axle is strictly forbidden.

Chains cannot be fitted to tyres which are larger than those originally fitted to the vehicle.

Snow or Winter tyres

We would recommend that these be fitted to all **four wheels** to ensure that your vehicle retains maximum adhesion.

Warning: These tyres sometimes have a specific direction of rotation and a maximum speed index which may be lower than the maximum speed of your vehicle.



Snow chains may only be fitted to tyres of the same size as those originally fitted to **your vehicle**.

Studded tyres

This type of equipment may only be used for a limited period and as laid down by local legislation. It is necessary to observe the speed specified by current legislation.

These tyres must, at a minimum, be fitted to the two front wheels.

Snow or Winter tyres

We recommend that these be fitted to all four wheelers to ensure that your vehicle remains maximum adhesion.

Warning:

These tyres sometimes have a specific direction of rotation and a maximum speed index which may be lower than the maximum speed of your vehicle.

In all cases, we would recommend that you contact an authorised dealer who will be able to advise you on the choice of equipment which is most suitable for your vehicle.

FRONT LIGHTS-CHANGINE HEAD LAMP MAIN BULB

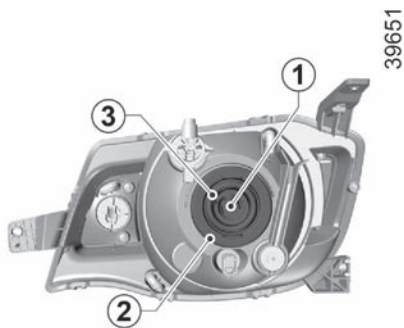

- Follow the steps under BONNET section to open the bonnet
 - Remove the Electric harness connector **1**.
 - Remove the Dust cap from head lamp bulb mounting area **2**.
 - Release the lock spring **3**.
 - Remove the head lamp main bulb and replace the bulb with the new one.
 - Once the new lamp is fitted, follow the steps vice-versa to assemble other parts in lamp unit. Make sure the Dust cap is re-fitted correctly.
- DO NOT TOUCH BULB GLASS. HOLD IT BY ITS BASE**

The head lamp bulbs can be replaced. However, we recommend you to have them replaced with the approved dealer if it proves difficult.

To comply with legislation or as a precaution, you can obtain an emergency kit from your approved dealer containing a set of spare bulbs and fuses.



The engine may be hot during operations in close proximity. In addition, the engine cooling fan may come on at any moment.

Risk of injury.



The bulbs are under pressure and can break when replaced.

Risk of injury.

FUSES (1/3)

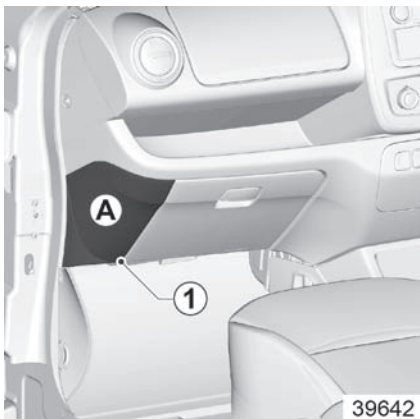

Passenger compartment fuses A

If any electrical component does not work, check the condition of the fuses. Pull the flap A from the lower edge to remove it to access the fuses.

To comply with current legislation, or as a precaution, you can obtain an emergency kit from your approved dealer containing a set of spare bulbs and fuses.

Removing the fuses

Remove the fuse, located at the back of flap A from position 1.

To remove the fuse, slide the fuse.

It is not advisable to use the free fuse locations.



The engine may be hot when working in close proximity. In addition, the engine cooling fan may come on at any moment.

Risk of injury.



Check the fuse in question and replace it,
If a fuse is fitted where the rating is too high, it may cause the electrical circuit to overheat (risk of fire) in the event of an item of equipment using an excessive amount of current.

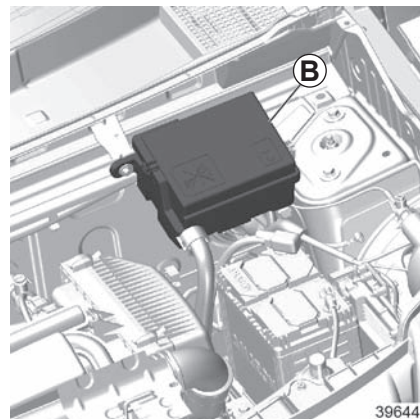

Fuses in engine compartment B

Some functions are protected by fuses located in the engine compartment (unit B).

However, because of their reduced accessibility, **we advise you to have your fuses replaced by an approved Dealer.**

FUSES (2/3)

Allocation of fuses in the passenger compartment

(the presence of certain fuses DEPENDS ON THE VEHICLE EQUIPMENT LEVEL)

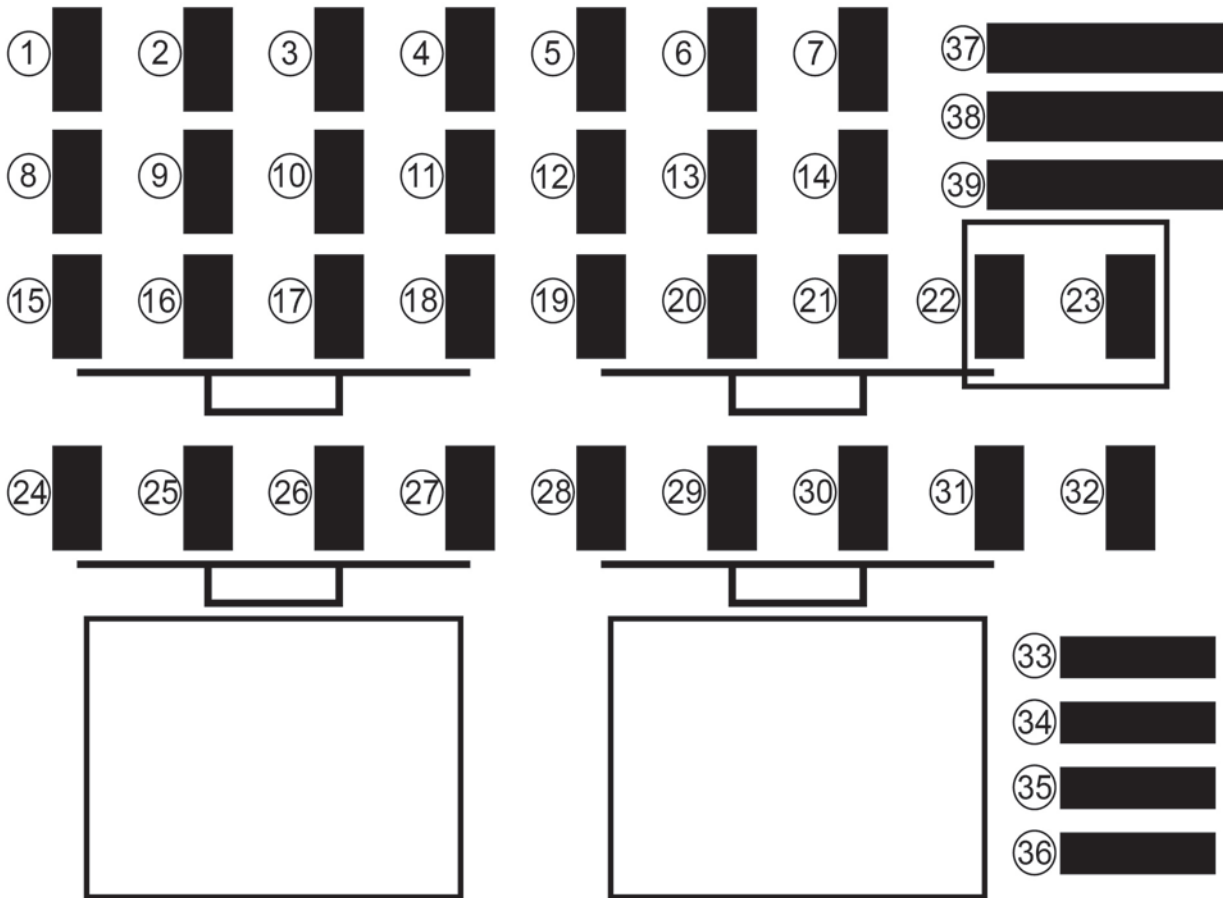

FUSES (3/3)

Number	Allocation
1	Empty location
2	Left-hand main beam headlight
3	Right-hand main beam headlight
4	Left-hand dipped beam headlight
5	Right-hand dipped beam headlight
6	Left-hand side light
7	Cluster /Radio/ Ultra low cost/Amplifier
8	First Row Accessory Socket
9	Blower Motor
10	Fuel Pump Fuse

Number	Allocation
11	Instrument panel- Automatic transmission
12	Roof Light
13	Cluster
14	Low Beam
15	Radio/Ultra low cost/ Amplifier/Diagnostic Socket, Roof Light
16	Empty location
17	Cluster
18	Lighting Switch
19	Electrical Door Locking
20	Electrical Door Locking
21	Electrical Door Locking

Number	Allocation
22 and 23	Empty Location
24	Cluster,Fuel pump Relay, Injection Engine Control Unit/Starter
25	Stop Light Switch, Radio/ Ultra Low cost
26	Rear Light Switch
27	Windshield Motor
28	Front Dual Window Lift
29	Power Steering
30	Air-Bag
31	Transponder Ring
32 to 35	Empty Location
36	Instrument panel/Starter- Manual transmission
37 to 39	Empty Location

RADIO FREQUENCY REMOTE CONTROL: batteries



39533

Replacing the remote control battery

Insert a minus screw driver into the slit of the Decor shell and twist it to separate the Decor shell from the lower part.

The batteries are available from approved Dealers, and their service life approximately two years.

Check that there is no dye on the battery: risk of an incorrect electrical contact.

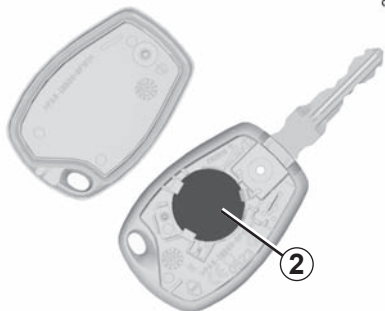

33274

Replace battery **2** according to the direction marked on the cover.

Recommended battery: Contact approved Renault Dealer for replacement of the battery.

Note: It is not advisable to touch the electronic circuit in the key cover when replacing the battery.

When refitting, ensure that the cover is correctly clipped on and the screw tightened.

26913



Do not throw away your used batteries; give them to an organisation responsible for collecting and recycling batteries.

BATTERY: troubleshooting (1/2)

To avoid all risk of sparks:

- Ensure that all electrical equipments (courtesy lights, etc.) are switched off before disconnecting or reconnecting the battery;
- when charging, stop the charger before connecting or disconnecting the battery;
- to avoid creating a short circuit between the terminals, do not place metal objects on the battery;
- always wait at least one minute after the engine has been switched off before disconnecting a battery;
- make sure that you reconnect the battery terminals after refitting.

Connecting a battery charger

The battery charger must be compatible with a battery with nominal voltage of 12 volts.

Do not disconnect the battery when the engine is running. **Follow the instructions given by the manufacturer of the battery charger you are using.**



Some batteries may have specific conditions for re-charging. Consult your approved dealer. Avoid the risk of sparks, as this could cause a sudden explosion, and always charge the battery in a well-ventilated area.

Risk of serious injury.



Handle the battery with care as it contains sulphuric acid, which must not come into contact with eyes or skin. If it does, wash the affected area with plenty of cold water and consult a doctor, if necessary.

Ensure that naked flames, red hot objects and sparks do not come into contact with the battery as there is a risk of explosion.

The engine may be hot when carrying out operations in close proximity. In addition, the engine cooling fan can come on at any moment.

Risk of injury.

BATTERY: troubleshooting (2/2)

Starting the vehicle using the battery from another vehicle

If you have to use the battery from another vehicle to start, obtain suitable jump leads (with a large cross section) from an approved dealer or, if you already have jump leads, ensure that they are in perfect condition.

The two batteries must have an identical nominal voltage of 12 volts. The battery supplying the current should have a capacity (amp-hours, Ah) which is at least the same as that of the discharged battery.

Ensure that there is no risk of contact between the two vehicles (risk of short circuiting when the positive terminals are connected) and that the discharged battery is properly connected. Switch off your vehicle ignition.

Start the engine of the vehicle supplying the current and run it at an intermediate engine speed.

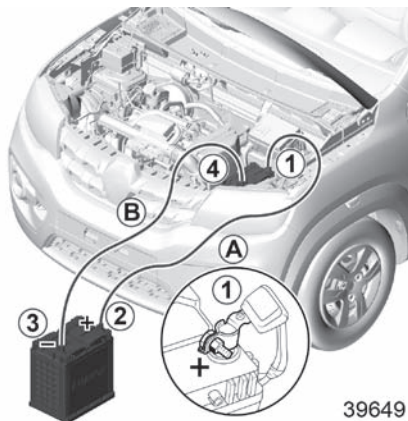

Connect the positive cable (+) **A** to the (+) terminal **1** of the discharged battery, then to the (+) terminal **2** of the battery supplying the current.

Connect the negative cable (-) **B** to the (-) **3** terminal of the battery supplying the current and then to the (-) **4** terminal of the discharged battery.

Start the engine as normal. As soon as it starts, disconnect cables **A** and **B** in reverse order (**4-3-2-1**).



Check that there is no contact between leads **A** and **B** and that the positive lead **A** is not touching any metal parts on the vehicle supplying the current.

Risk of serious injury and/or damage to the vehicle.

TOWING



39650

The steering wheel must be unlocked and the ignition key must be in ignition **ON** condition to provide brake lights and hazard warning lights on the towed vehicle. At night the vehicle must have its lights on.



It is prohibited to hang the car to lower arm or Rear Axle. To hang car there is a specific place provided.



Do not leave the tools unsecured inside the vehicle as they may come loose under braking.

Front towing point 1.

This towing point must only be used for towing: never use it for lifting the vehicle directly or indirectly.



Do not remove the key from the ignition when the vehicle is being towed.

When the engine is stopped, steering and braking assistance are not operational.

- Do not leave the tools unsecured inside the vehicle as they may come loose under braking.
- A vehicle must not be towed if it is not fit to be driven.
- Use a rigid towing bar. If a rope or cable is used (where the law allows this), the vehicle being towed must be able to brake.
- A vehicle must not be towed if it is not fit to be driven.

ACCESSORIES



Electrical and electronic accessories

Before installing this type of accessory, make sure it is compatible with your vehicle. You can get advice from an authorised dealer.

Connect accessories with a maximum power of 120 watts only. **Fire hazard.**

No work may be carried out on the vehicle's electrical or radio circuits, except by authorised dealers: an incorrectly connected system may result in damage being caused to the electrical equipment and/or the components connected to it.

If the vehicle is fitted with any aftermarket electrical equipment, make sure that the installation is correctly protected by a fuse. Establish the rating and position of this fuse.

Use of transmission/receiving devices (telephones, CB equipment etc.).

Telephones and CB equipment with integrated aerials may cause interference to the electronic systems originally fitted to the vehicle: it is advisable only to use equipment with an external aerial. **Furthermore, we remind you of the need to conform to the legislation in force concerning the use of such equipment.**

Fitting after-market accessories

If you wish to install accessories on the vehicle: please contact an authorised dealer. Also, to ensure the correct operation of your vehicle, and to avoid any risk to your safety, we recommend that you use only accessories specifically designed for your vehicle, which are the only accessories for which the manufacturer will provide a warranty.

If you are using an anti-theft device, only attach it to the brake pedal.

Obstructions to the driver

On the driver's side, only use mats suitable for the vehicle, attached with the pre-fitted components, and check the fitting regularly. Do not lay one mat on top of another. **There is a risk of wedging the pedals.**

OPERATING FAULTS (1/3)

The following advice will enable you to carry out quick, temporary repairs. For safety reasons you should always contact an approved dealer as soon as possible.

The starter is activated	POSSIBLE CAUSES	WHAT TO DO
Warning lights dim or fail to come on; the starter does not run.	Battery terminals disconnected, oxidised or incorrectly secured.	Retighten them, reconnect them or clean them if they are oxidised.
	Battery discharged or worn.	Connect another battery to the faulty battery. Refer to the information on “Battery: troubleshooting” in Section 5 or replace the battery if necessary. Do not push the vehicle if the steering column is locked.
The engine is not starting.	Starting conditions are not fulfilled.	Please refer to the information on “Starting, stopping the engine” in Section 2.
The steering column remains locked.	Steering wheel locked.	To unlock, gently move the key and the steering wheel (refer to the information on the “Ignition switch” in Section 2).
Traces of condensation in the lights.	This is not a fault. Traces of condensation are a natural phenomenon caused by variations in temperature. The traces will disappear slowly once the lights are switched on.	

OPERATING FAULTS (2/3)

On the road	POSSIBLE CAUSES	WHAT TO DO
Vibrations.	Tyres not inflated to correct pressures, incorrectly balanced or damaged.	Check the tyre pressures; if this is not the cause, have their condition checked by an approved dealer.
Coolant boiling in the coolant reservoir.	Mechanical fault: cylinder head gasket damaged, faulty coolant pump.	Stop the engine. Contact an approved dealer.
	Engine cooling fan not working.	Contact an approved dealer.
Smoke under the bonnet.	Short circuit or cooling system leak.	Stop, switch off the ignition, move away from the vehicle and contact an approved dealer.
The oil pressure warning light comes on:		
on a bend or under braking	The engine oil level is too low.	Top up the engine oil level (refer to the information on "Engine oil level: topping up/filling" in Section 4).
at idle speed	Low oil pressure.	Go to your nearest approved dealer.
The oil pressure warning light takes a long time to go out or remains lit during acceleration.	Loss of oil pressure.	Stop the vehicle: contact an approved dealer.

OPERATING FAULTS (3/3)

On the road	POSSIBLE CAUSES	WHAT TO DO
The engine overheats. The coolant temperature indicator light comes on.	Engine cooling fan not working.	Stop the vehicle, switch off the engine and contact an approved dealer.
	Coolant leaks.	Stop the vehicle, switch off the engine and check the coolant reservoir: it should contain fluid. If there is no coolant, consult an approved dealer as soon as possible.
The wiper does not work.	Wiper blade stuck.	Free the blades before using the wipers.
	Faulty electrical circuit.	Consult an approved dealer.
The wiper does not stop.	Faulty electrical controls.	Consult an approved dealer.
Direction indicators flashing more quickly.	Bulb blown.	Replace the bulb.
The direction indicators do not work.	Faulty electrical circuit.	Consult an approved dealer.
The headlights do not switch on or off.	Faulty electrical circuit or control.	Consult an approved dealer.
Abnormal white smoke from the exhaust	Mechanical fault: damaged cylinder head gasket.	Stop the engine. Contact an approved dealer.



Radiator: If there is a significant lack of coolant, remember that it must never be topped up using cold coolant while the engine is very warm. After any procedure on the vehicle which has involved even partial draining of the cooling system, it must be refilled with a new mixture prepared in the correct proportions. Reminder: only products approved by the Technical Department may be used for this purpose.

Section 6: Technical specifications

Identification plates	6.2
Engine specifications	6.3
Dimensions	6.4
Replacement parts and repairs	6.5
Service sheets	6.6
Anticorrosion check	6.12
	6.1

IDENTIFICATION PLATES



Vehicle Identification Number

The information shown on the vehicle identification plate should be quoted on all correspondence or orders.

Open up the insulator to access the Vehicle Identification number Plate.

Vehicle identification plate A :

Identification number.

ENGINE SPECIFICATIONS

Versions	0.8 12V	1.0 12V
Engine type (see engine plate)	BR08DE	BR10DE
Cubic capacity (cc)	799	999
Type of fuel octane rating	Petrol The use of unleaded petrol is essential, with the octane rating as stated on the label inside the fuel filler flap.	
Spark plugs	Only use spark plugs specified for your vehicle's engine. The type should be marked on a label stuck inside the engine compartment. If it is not, then Contact your approved Dealer for replacement of Spark Plugs. Fitting spark plugs other than those specified may damage the engine.	

DIMENSIONS (in metres)

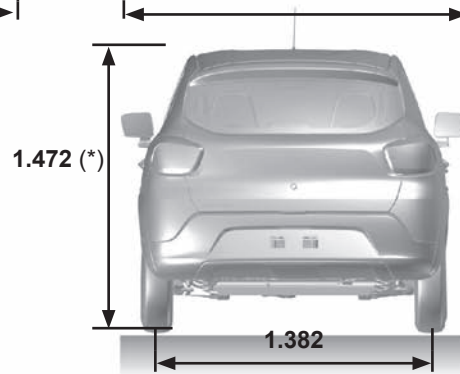
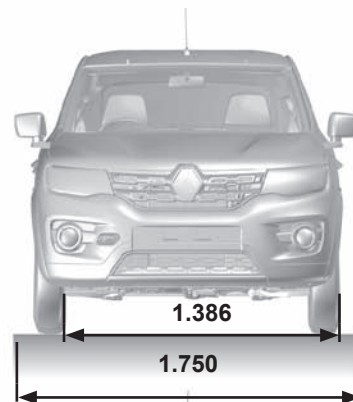
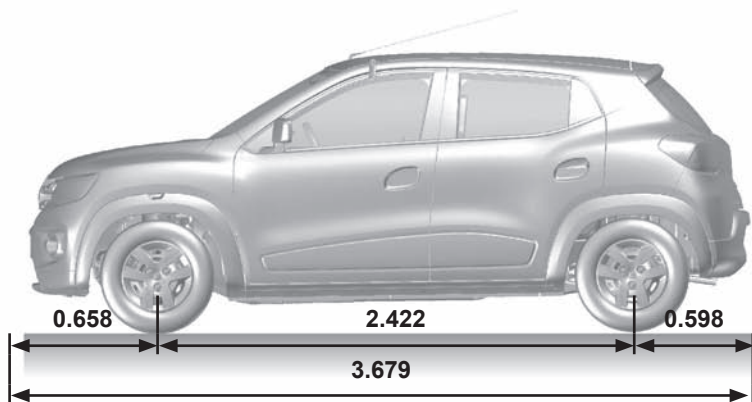

(*) unladen

6.4

39659

REPLACEMENT PARTS AND REPAIRS

Original parts are based on strict specifications and are subject to highly specialized tests. Therefore, they are of at least the same level of quality as the parts fitted originally.

If you fit genuine replacement parts always to your vehicle, it will perform well. Furthermore, repairs carried out within manufacturers network using original parts are guaranteed according to the conditions set out on the reverse of repair order.

SERVICE SHEETS (1/6)

VIN:

Date: _____ Miles (Km): _____		Invoice number: _____		Comments/miscellaneous	
Type of operation:		Stamp			
Service <input type="checkbox"/>					
..... <input type="checkbox"/>					
Anti-corrosion check:					
OK <input type="checkbox"/> Not OK* <input type="checkbox"/>					
*See specific page					

Date: _____ Miles (Km): _____		Invoice number: _____		Comments/miscellaneous	
Type of operation:		Stamp			
Service <input type="checkbox"/>					
..... <input type="checkbox"/>					
Anti-corrosion check:					
OK <input type="checkbox"/> Not OK* <input type="checkbox"/>					
*See specific page					

Date: _____ Miles (Km): _____		Invoice number: _____		Comments/miscellaneous	
Type of operation:		Stamp			
Service <input type="checkbox"/>					
..... <input type="checkbox"/>					
Anti-corrosion check:					
OK <input type="checkbox"/> Not OK* <input type="checkbox"/>					
*See specific page					

SERVICE SHEETS (2/6)

VIN:

Date: _____ Miles (Km): _____		Invoice number: _____		Comments/miscellaneous	
Type of operation:		Stamp			
Service <input type="checkbox"/>					
..... <input type="checkbox"/>					
Anti-corrosion check:					
OK <input type="checkbox"/> Not OK* <input type="checkbox"/>					
*See specific page					

Date: _____ Miles (Km): _____		Invoice number: _____		Comments/miscellaneous	
Type of operation:		Stamp			
Service <input type="checkbox"/>					
..... <input type="checkbox"/>					
Anti-corrosion check:					
OK <input type="checkbox"/> Not OK* <input type="checkbox"/>					
*See specific page					

Date: _____ Miles (Km): _____		Invoice number: _____		Comments/miscellaneous	
Type of operation:		Stamp			
Service <input type="checkbox"/>					
..... <input type="checkbox"/>					
Anti-corrosion check:					
OK <input type="checkbox"/> Not OK* <input type="checkbox"/>					
*See specific page					

SERVICE SHEETS (3/6)

VIN:

Date: _____ Miles (Km): _____		Invoice number: _____		Comments/miscellaneous	
Type of operation:		Stamp			
Service <input type="checkbox"/>					
..... <input type="checkbox"/>					
Anti-corrosion check:					
OK <input type="checkbox"/> Not OK* <input type="checkbox"/>					
*See specific page					

Date: _____ Miles (Km): _____		Invoice number: _____		Comments/miscellaneous	
Type of operation:		Stamp			
Service <input type="checkbox"/>					
..... <input type="checkbox"/>					
Anti-corrosion check:					
OK <input type="checkbox"/> Not OK* <input type="checkbox"/>					
*See specific page					

Date: _____ Miles (Km): _____		Invoice number: _____		Comments/miscellaneous	
Type of operation:		Stamp			
Service <input type="checkbox"/>					
..... <input type="checkbox"/>					
Anti-corrosion check:					
OK <input type="checkbox"/> Not OK* <input type="checkbox"/>					
*See specific page					

SERVICE SHEETS (4/6)

VIN:

Date: _____ Miles (Km): _____		Invoice number: _____		Comments/miscellaneous	
Type of operation:		Stamp			
Service <input type="checkbox"/>					
..... <input type="checkbox"/>					
Anti-corrosion check:					
OK <input type="checkbox"/> Not OK* <input type="checkbox"/>					
*See specific page					

Date: _____ Miles (Km): _____		Invoice number: _____		Comments/miscellaneous	
Type of operation:		Stamp			
Service <input type="checkbox"/>					
..... <input type="checkbox"/>					
Anti-corrosion check:					
OK <input type="checkbox"/> Not OK* <input type="checkbox"/>					
*See specific page					

Date: _____ Miles (Km): _____		Invoice number: _____		Comments/miscellaneous	
Type of operation:		Stamp			
Service <input type="checkbox"/>					
..... <input type="checkbox"/>					
Anti-corrosion check:					
OK <input type="checkbox"/> Not OK* <input type="checkbox"/>					
*See specific page					

SERVICE SHEETS (5/6)

VIN:

Date: _____ Miles (Km): _____		Invoice number: _____		Comments/miscellaneous	
Type of operation: Service <input type="checkbox"/> <input type="checkbox"/>		Stamp			
Anti-corrosion check: OK <input type="checkbox"/> Not OK* <input type="checkbox"/> *See specific page					
Date: _____ Miles (Km): _____		Invoice number: _____		Comments/miscellaneous	
Type of operation: Service <input type="checkbox"/> <input type="checkbox"/>		Stamp			
Anti-corrosion check: OK <input type="checkbox"/> Not OK* <input type="checkbox"/> *See specific page					
Date: _____ Miles (Km): _____		Invoice number: _____		Comments/miscellaneous	
Type of operation: Service <input type="checkbox"/> <input type="checkbox"/>		Stamp			
Anti-corrosion check: OK <input type="checkbox"/> Not OK* <input type="checkbox"/> *See specific page					

SERVICE SHEETS (6/6)

VIN:

Date: _____ Miles (Km): _____		Invoice number: _____		Comments/miscellaneous	
Type of operation:		Stamp			
Service <input type="checkbox"/>					
..... <input type="checkbox"/>					
Anti-corrosion check:					
OK <input type="checkbox"/> Not OK* <input type="checkbox"/>					
*See specific page					

Date: _____ Miles (Km): _____		Invoice number: _____		Comments/miscellaneous	
Type of operation:		Stamp			
Service <input type="checkbox"/>					
..... <input type="checkbox"/>					
Anti-corrosion check:					
OK <input type="checkbox"/> Not OK* <input type="checkbox"/>					
*See specific page					

Date: _____ Miles (Km): _____		Invoice number: _____		Comments/miscellaneous	
Type of operation:		Stamp			
Service <input type="checkbox"/>					
..... <input type="checkbox"/>					
Anti-corrosion check:					
OK <input type="checkbox"/> Not OK* <input type="checkbox"/>					
*See specific page					

ANTICORROSION CHECK (1/6)

If the continuation of the warranty is subject to repair, it is indicated below.

VIN:

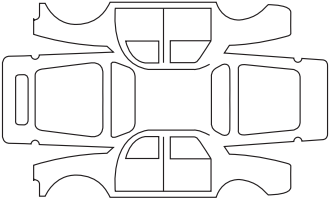
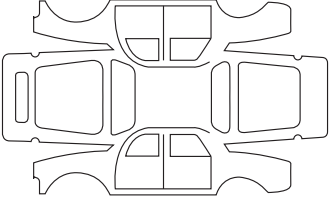
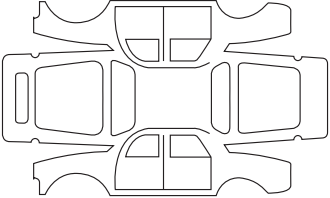
Corrosion repair operation to be carried out:		Stamp
Date of repair:		
Repair to be carried out:		Stamp
Date of repair:		
Repair to be carried out:		Stamp
Date of repair:		

ANTICORROSION CHECK (2/6)

If the continuation of the warranty is subject to repair, it is indicated below.

VIN:

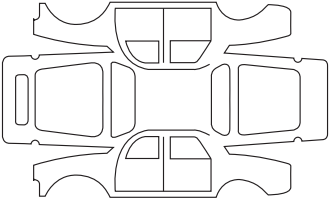
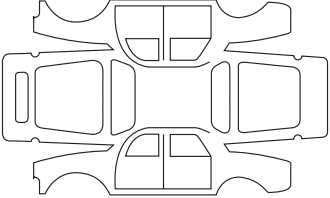
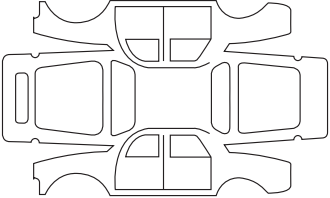
Corrosion repair operation to be carried out:		
Corrosion repair operation to be carried out:		Stamp
Date of repair:		
Repair to be carried out:		
Repair to be carried out:		Stamp
Date of repair:		
Repair to be carried out:		
Repair to be carried out:		Stamp
Date of repair:		

ANTICORROSION CHECK (3/6)

If the continuation of the warranty is subject to repair, it is indicated below.

VIN:

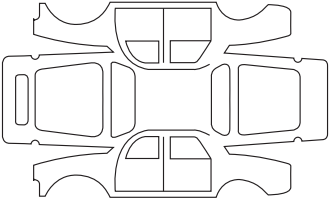
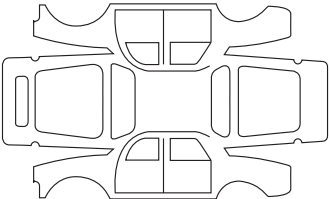
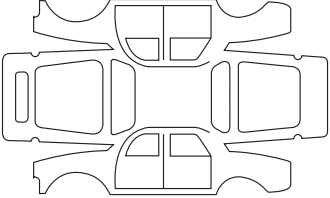
Corrosion repair operation to be carried out:		Stamp
Date of repair:		
Repair to be carried out:		Stamp
Date of repair:		
Repair to be carried out:		Stamp
Date of repair:		

ANTICORROSION CHECK (4/6)

If the continuation of the warranty is subject to repair, it is indicated below.

VIN:

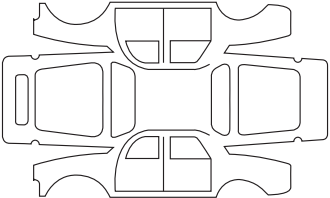
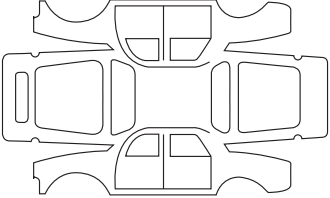
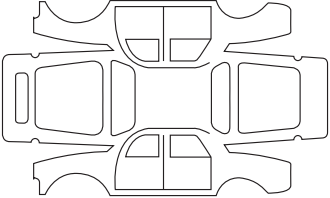
Corrosion repair operation to be carried out:		
Corrosion repair operation to be carried out:		Stamp
Date of repair:		
Repair to be carried out:		
Repair to be carried out:		Stamp
Date of repair:		
Repair to be carried out:		
Repair to be carried out:		Stamp
Date of repair:		

ANTICORROSION CHECK (5/6)

If the continuation of the warranty is subject to repair, it is indicated below.

VIN:

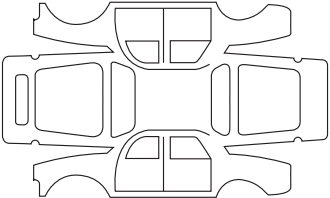
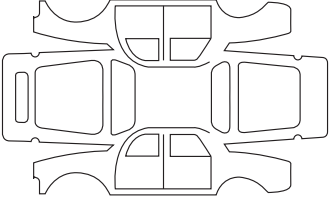
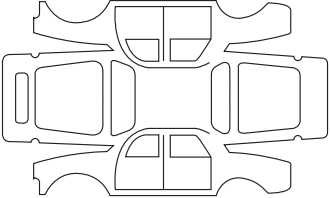
Corrosion repair operation to be carried out:		Stamp
Date of repair:		
Repair to be carried out:		Stamp
Date of repair:		
Repair to be carried out:		Stamp
Date of repair:		

ANTICORROSION CHECK (6/6)

If the continuation of the warranty is subject to repair, it is indicated below.

VIN:

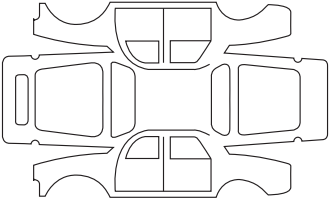
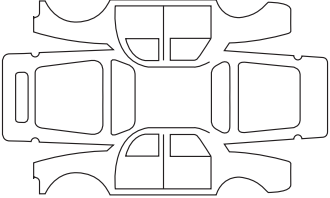
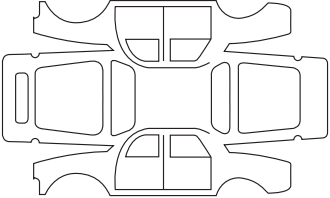
Corrosion repair operation to be carried out:		
Corrosion repair operation to be carried out:		Stamp
Date of repair:		
Repair to be carried out:		
Repair to be carried out:		Stamp
Date of repair:		
Repair to be carried out:		
Repair to be carried out:		Stamp
Date of repair:		



ALPHABETICAL INDEX (1/3)

A

accessories.....	5.17
accessories socket.....	3.9
adjusting your driving position.....	1.8
air bag.....	1.12 – 1.13
air conditioning.....	3.4 → 3.6
air vents.....	3.2 – 3.3
anti-corrosion check.....	6.12 → 6.17
anti-corrosion protection.....	4.11
antipollution advice.....	2.7 → 2.9

B

battery.....	4.8 – 4.9
troubleshooting.....	5.14 – 5.15
battery (remote control).....	5.13
bonnet.....	4.2
brake fluid.....	4.6

C

central door locking.....	1.4
changing a wheel.....	5.4 – 5.5
changing gear.....	2.5 – 2.6, 2.10 → 2.13
child booster seat.....	1.14 – 1.15
child restraint/seat.....	1.14 → 1.20
child safety.....	1.14 → 1.20
child seats.....	1.14 – 1.15
children (safety).....	1.16 → 1.20
cleaning: inside the vehicle.....	4.13 – 4.14
closing the doors.....	1.5 – 1.6
control instruments.....	1.23 → 1.28
courtesy light.....	3.8

D

dashboard.....	1.21 – 1.22
dimensions.....	6.4
doors.....	1.4 → 1.6
driving.....	1.21 – 1.22, 2.2 – 2.4, 2.7 → 2.13

E

electric door locking.....	1.4
electric windows.....	3.7
emergency spare wheel.....	5.2, 5.4 – 5.5
engine technical specifications.....	6.3
engine coolant.....	4.7
engine immobiliser system.....	1.7
engine immobiliser (switch).....	2.2
engine oil.....	4.3 → 4.5
engine oil capacity.....	4.3 → 4.5
engine oil grade.....	4.3 → 4.5
engine specifications.....	6.3

F

faults operating faults.....	5.18 → 5.20
filter.....	4.6 – 4.7
fittings.....	3.9
front lights-changing head lamps main bulbs.....	5.9
front seat adjustment.....	1.8
front seats.....	1.8
adjustment.....	1.8
fuel advice on fuel economy.....	2.7 → 2.9
grade.....	1.33
fuel economy.....	2.7 → 2.9
fuel filler cap.....	1.33
fuel grade.....	1.33

ALPHABETICAL INDEX (2/3)

fuel tank 1.33 – 1.34
fuses 5.10 → 5.12

G

gear lever 2.5 – 2.6
glove box 3.9
grab handle 3.8

H

handbrake 2.5 – 2.6
hands-free telephone integrated control 3.12
hazard warning lights signal 1.30
headlight beam adjustment 1.29
heating and air conditioning system 3.4 → 3.6
heating system 3.4 – 3.5
horn 1.30

I

ignition switch 2.2
indicators:
 direction indicators 1.30
 instrument panel 1.23 → 1.25
instrument panel 1.23 → 1.25
instrument panel messages 1.26 – 1.27
interior trim
 maintenance 4.13 – 4.14

K

keys 1.2 – 1.3

L

levels 4.6 – 4.7
lifting the vehicle
 changing a wheel 5.4 – 5.5
lighting:
 exterior 1.27

lights 1.28
lights:

 dipped beam headlights 1.28
 main beam headlights 1.28
 side lights 1.28
locking the doors 1.4

M

maintenance:
 bodywork 4.11 – 4.12
 interior trim 4.13 – 4.14
 mechanical 4.8 – 4.9, 6.6 → 6.11
multimedia equipment 3.12

N

navigation 3.12
navigation system 3.12

O

opening the doors 1.5 – 1.6
operating faults 5.18 → 5.20

P

paintwork
 maintenance 4.11 – 4.12
practical advice 5.18 → 5.20
puncture 5.2

R

radio 7.7
radio frequency remote control/key
 use 1.2 – 1.3
rear seat 3.10
rear view mirrors 1.31
remote control door locking
 batteries 5.13

ALPHABETICAL INDEX (3/3)

remote control door locking unit	1.4
replacement parts	6.5
reverse gear	
selecting	2.5 – 2.6, 2.10 → 2.13
running in	2.2

S

seat belts	1.9 → 1.11
sequential gearbox	2.10 → 2.13
service sheets	6.6 → 6.11
signals and lights	1.28
starting	2.2 → 2.4
starting the engine	2.3 – 2.4
storage compartment	3.9
storage compartments	3.9
sun visor	3.8

T

tailgate	3.11
tanks and reservoirs	
brake fluid	4.6
coolant	4.7
tanks and reservoirs:	
windscreen washer	4.7
technical specifications	6.3, 6.4
telephone	3.12
tool kit	5.3
towing	
breakdown	5.16
towing hitch	5.16
transporting children	1.14 – 1.15
trip computer and warning system	1.26 – 1.27
tyre pressure	4.10, 5.7
tyres	4.10, 5.6 → 5.8

V

vehicle identification plates	6.2
ventilation	
heating and air conditioning system	3.4 → 3.6

W

warning buzzer	1.27
warning lights	1.23 → 1.27
washing	4.11 – 4.12
wheel trim	5.3
windows	3.7
windscreen washer	1.32, 4.6
wipers	1.32

Section 8: Radio

Introduction to controls.....	7.8
General Introduction.....	7.9
Auxillary audio function.....	7.9
Hands-free function.....	7.9
Radio (AM/FM).....	7.9
Switch ON/OFF.....	7.10
Source selection.....	7.10
Volume/Mute.....	7.10
Listening to radio.....	7.10
Storage of radio stations.....	7.10
Auxillary audio sources/services.....	7.11
Making/Receiving calls.....	7.12
Audio settings.....	7.12
Radio settings.....	7.13
Phone settings.....	7.13
Bluetooth settings.....	7.13
Connecting to Bluetooth.....	7.13

RADIO GUIDE(1/7)

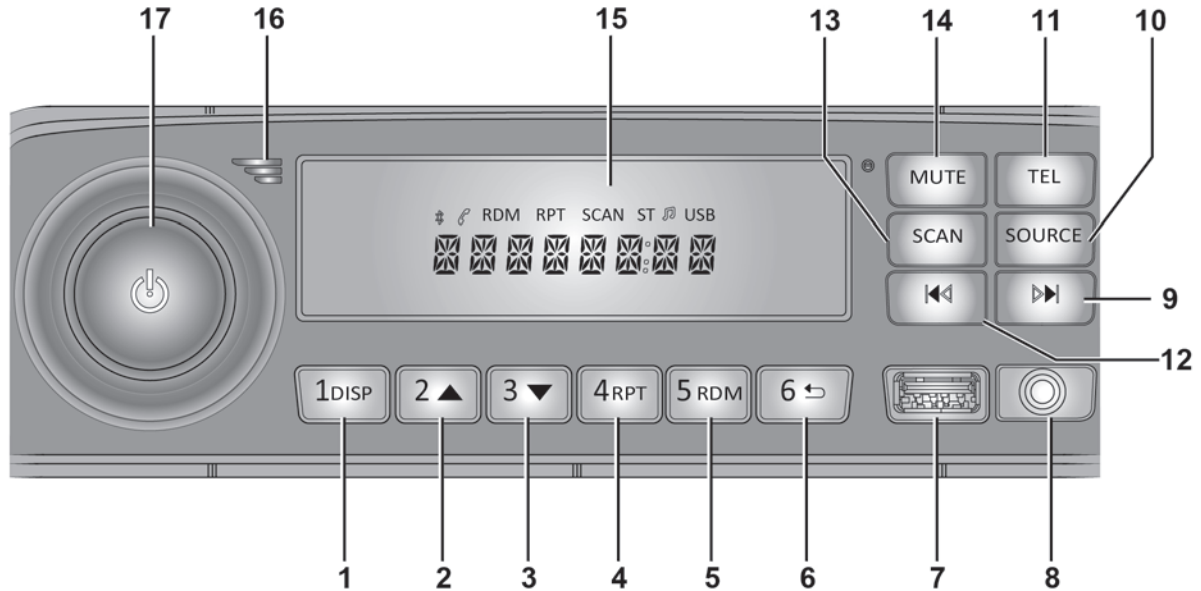

It is essential to follow the precautions in following pages when using the system, both in the interest of safety and to prevent material damage. User must always comply with laws of the country in which user are travelling.

RADIO GUIDE(2/7)

- 1 Displays the artists of tracks / FM tuned in / Preset station 1 for FM
- 2 Select previous folder from the auxiliary storage/ Preset station 2 for FM
- 3 Select next folder from the auxiliary storage/ Preset station 3 for FM
- 4 Repeat a track/ Preset station 4 for FM
- 5 Selection of tracks at random/ preset station 5 for FM-Random
- 6 Exits to main menu / previous track/ Preset station 6 for FM
- 7 Play Music from auxiliary source via USB port
- 8 Play Music from auxiliary source via AUX port
- 9 Select next track or fast forward or change to next station
- 10 Select the Required connected medium
- 11 Answer a call
- 12 Select previous track or fast rewind or change to previous station
- 13 Search for stations in a given band
- 14 Mute the volume / Pause & play depending on the mode
- 15 Display – Vacuum Fluid Display (VFD)
- 16 Mic for answering calls
- 17 Power ON or OFF push button / Source Volume control



Precautions concerning the equipment

Do not attempt to dismantle or modify the system as there is a risk of damage to equipment and fire

Contact approved dealer in the event of malfunction and for all operations involving disassembly.

Do not stick paper to the radio. After prolonged use remove the USB key.

Precautions using the phone

There are laws which govern the use of phones in vehicles. They do not necessarily authorise the use of hands-free phone systems under all driving conditions: drivers must be in control of their vehicles all the times.

Using a phone whilst driving is a significant distraction and risk factor during all stages of use (dialling, communicating, searching for a number in handset memory etc.)

Precautions when operating the audio system

Operate the controls (on the dash or near the steering wheel) and read the information on the screen only when road conditions allow.

RADIO GUIDE(3/7)

Introduction

The audio system comprises of the following functions:

- USB
- Bluetooth hands-free phone system
- Radio(AM,FM with RDS)

Auxiliary audio function

User can listen stereo directly through vehicle's speaker. There are several ways of connecting user's personal stereo, depending on the type of device user has and the vehicle offers:

- USB socket
- Jack socket
- Bluetooth connection

For more information on compatible devices, contact an approved dealer.

Hands-Free function

The hands free Bluetooth system provides the following function without having to handle user's phone:

- Receive a call
- Reject a call
- Hold and unhold

This function also enables the user to listen to audio files via handsfree Bluetooth function.

NOTE:

User's Hands-free system is only intended to communication by reducing the risk factors, without removing them completely .User must comply with laws of the country in which travelling.

Radio (AM, FM with RDS)

The radio enables FM radio to be played by short pressing button 17(Power push button). The radio stations are classified by wavelength:

FM(frequency modulation) and

AM(amplitude modulation)

The RDS radio system enables the names of certain stations to be displayed if it is broadcasted by FM radio stations.

Set the volume to a reasonable level so that outside noise can be heard



Precautions concerning the equipment

Do not attempt to dismantle or modify the system as there is a risk of damage to equipment and fire

Contact approved dealer in the event of malfunction and for all operations involving disassembly.

Do not stick paper to the radio. After prolonged use remove the USB key.

Using a phone whilst driving is a significant distraction and risk factor during all stages of use (dialling, communicating, searching for a number in handset memory etc.)

Precautions when operating the audio system

Operate the controls (on the dash or near the steering wheel) and read the information on the screen only when road conditions allow.

RADIO GUIDE(4/7)

Switchin On and Off

Short Press 17 to switch on user's radio system. The audio system can be used with ignition off .It will run till the battery lasts. Switch off the radio by long pressing 17.

Source Selection

User can choose from various sources by short press the button 10.

Volume Controls

Adjust the volume by rotating button 17 either clockwise or anticlockwise directions

The displays shows volume setting value (from 00 to 36)

Increase the volume by rotating in clockwise direction

Decrease the volume by rotating in anti-clockwise direction

Mute Function

The Mute function can be enabled by pressing the button 14.

To continue to listen press same button briefly.

User can Play or pause using the same button when radio is connected to Auxiliary devices via. USB or AUX port (button no 7 and 8)

Listening to Radio

Press button 10 to choose from FM - 1 FM - 2 or AM.

FM 1 – stores the first 6 channels in the band automatically.

FM 2 – stores the next 6 channels in the band automatically.

AM – Amplitude Modulated wave band

Selecting a radio station

There are different modes for choosing a radio station.

1. Automatic search - It allows stations to be searched automatically scanning the selected band.

To access the station, press button 13.

To stop search short press button 13.

2. Manual search - This mode allows user search for stations manually by scanning the selected waveband.

To access the stations, press and hold button 9. Release button 9 to refine the search step by step.

In case of AM band the frequency increase or decrease by 9 KHz.

Storage of Radio stations

This operating mode allows user to listen to the radio stations that user have previously stored on demand.

Select a waveband, and then select a radio station using the modes described previously.

To store a station, press one of the buttons from 1 to 6 to store it in desired position.

It is possible to store 6 stations per waveband (FM 1, FM 2, or AM).

To recall the stored station, press one of the buttons from 1 to 6.

Listening to the Radio

When listening to the radio, briefly press button 13 to activate the auto store mode .The radio returns to the last Auto stored station played. User can select user's choice of station by using buttons from 1 to 6.

Note

Some buttons(from 1 to 6) may not correspond to a radio station if the automatic search function has found fewer than 6 six stations

The best reception will be programmed as channel 1 and can be selected by pressing button 1

RADIO GUIDE(5/7)

AF-RDS (Radio Data System) automatic returning

The frequency of an FM station changes according to the geographical area .Certain stations use the RDS system which allows automatic returning .The radio system is able to follow the changes in frequency of these stations.

Auxiliary audio sources

User's audio system has an auxiliary input port and a USB port to connect to external audio sources (Bt. portable audio sources, MP3 player)

There are several ways to connect user's portable audio player,

USB Socket

AUX port

Bluetooth connection

Note: The auxiliary audio sources formats can be MP3, WMA.

AUXILIARY INPUT: USB Socket

Connection

Connect the audio device to the USB socket through USB key.

Once the device's connector has been connected to the USB port, the track being played is displayed automatically.

Each press of (preset1) button 1 in USB will display the options File, Folder, Artist, Album, Title and the last selected from the list shall display in the display when the track is playing.

Each press of button 4 in USB shall guide through Repeat Track, Repeat Folder, RepeatT All options.

Each press of button 5 in USB shall guide through Random Folder, Ranodom All, Random Off options.

Auxiliary audio devices

An audio analog input pin of 3.5mm jack is used. Playback of the first audio file from the first folder on user's audio device begins automatically.

If users are in the menu structure user can change to previous and next track or folder by short pressing button 2 or 3 respectively

The random playback can be enabled by pressing button 5.

Bluetooth Connection

Connection can be established by connecting user's bluetooth enabled audio device. Switch on the Bluetooth in user's audio device and pair with the appropriate code. User's audio device will be controlled by radio.User can pause or play using the mute button.



If this is the first connection to the system, audio playback will begin with the first track from the folder of the source .Otherwise, playback will begin at the last track (if user is connecting the same device two consecutive times).

Maximum storage limit of the device supported shall be 64Gb

Once connected, user can no longer directly control user's portable digital audio player.

User must use the buttons on the front panel of the audio system

Only handle the personal stereo when traffic conditions permit

Store the portable audio player safely while driving (risk of being thrown in the event of sudden braking or impact)

The number of accessible function varies depending on the type of portable audio player and its compatibility with the audio system.

If the AUX system is disconnected then the system returns to the previous menu

No options are available for selecting a particular track or folder in Bluetooth Audi mode.

RADIO GUIDE(6/7)

Making or Receiving a call

The phone calls can be accessed from user's radio once it has been paired with user device.

User can pick the call in a single go. With the help of the speakers and mic user can make calling experience more comfortable.

Similarly user can make a call in a single go with the help of user's phone, mic and speakers conveniently.

The system supports holding calling when user's telephone is connected .If user receives a call when user is on another call, this new call can be put on hold.

User can switch between hand phone and speaker by using button 6.

User can hold first call and accept second call using button 1 or user can disconnect second call and resume first call using same button1. User can receive a call by short pressing button 11.

Connection Failure

In any case the key position is changed to off condition and radio gets switched off while user is on a call. The call gets automatically transferred to user's phone and user can call using user's hands free like a normal mobile.

Audio Settings

Radio gives access to settings for the music user listen to, by short pressing button 1 and selecting the features by turning the volume button and selecting the centre button for final selection of the value for the particular selected setting.

The various features supported by radio are as follows,

- Bass
- Treble
- Fader (front /rear balance)
- Balance (left/right balance)

Equalizer pre-sets such as Pop, Rock, Jazz, Soft, Classic, Voice.

User can modify the value of each setting by turning the volume wheel button 17 either clockwise or anti-clockwise directions.

The display indicates the type of setting user has selected and the value users have set for the setting.

The system exits once user short press the button 6 (ESC button).



It is recommended that user stop user's vehicle before entering a number or searching for a contact

User's hands-free phone system is only intended to facilitate communication by reducing the risk factors, without removing them completely. User must always comply with the laws of user's country in which user is travelling.

Note:

Audio settings are applicable to Bt. streaming or any audio device connection via. Bt.

Except folder selection and track selection and is independent of the radio.

RADIO GUIDE(7/7)

Radio Settings

The radio channels can be selected from a given bandwidth either by manual tuning mode or the first 6 channels are stored automatically

And the user can access them using buttons from 1 to 6 respectively. If the user tunes to a particular favourite channel the same can be saved in the channels and can be accessed using the same buttons i.e., 1 to 6.

Phone Settings

User can exit a call or attend a call by selecting the button 11 provided users have paired user's phone via. Bluetooth.

Bluetooth Settings

The bluetooth audio settings can be set by the user themselves. User can activate/deactivate the bluetooth function by pairing user's device with the radio system.

Connecting Bluetooth:

- Press Telephone Button 11
- Display shows BT ON, means the Bluetooth is in OFF state. Press the button 17 (Power) to switch ON the bluetooth.
- Rotate 17 (Volume control) to activate audio Bluetooth.
- Your mobile gets connected with audio device.
- Your mobile phone will prompt for a passcode. Type"1234" to pair.

The various settings supported by Bluetooth audio streaming are Bass, Treble, Fader (front/rear), Balance (left/right)

.User can activate or deactivate the Bluetooth function by pairing user's device with the radio system

