

CONCERT MARIMBAS

YM-5104A/5100A/4900A/4600A

取扱説明書

Owner's Manual

Руководство пользователя

使用手册

사용설명서

『安全上のご注意』および『ガススプリング取り扱いに関する注意事項』を必ずお読みください。

Make sure to read "Precautions for Handling Gas Spring" and "Precautions".

Обязательно прочтите разделы "ПРЕДОСТОРОЖНОСТИ ПРИ ОБРАЩЕНИИ С ПНЕВМАТИЧЕСКОЙ ПРУЖИНОЙ" и "МЕРЫ ПРЕДОСТОРОЖНОСТИ".

务请阅读“气弹簧操作注意事项”和“注意事项”。

"가스 스프링 취급상의 주의사항" 및 "주의사항" 을 반드시 읽어 주십시오 .

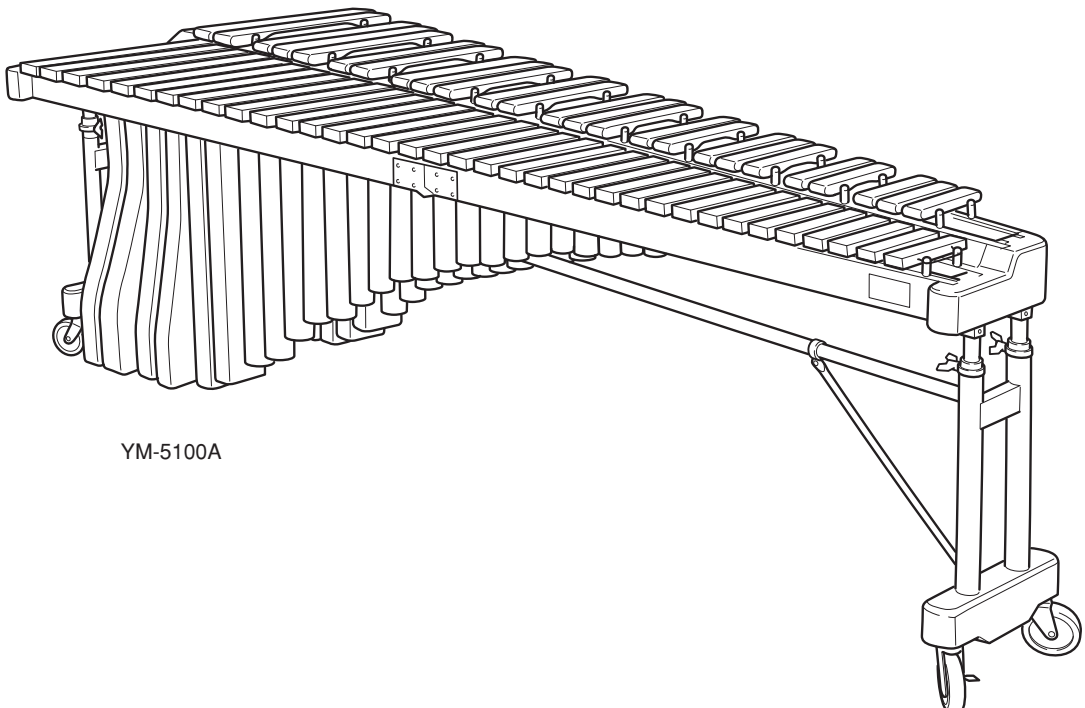

YM-5100A

PRECAUTIONS

Using the Concert Marimba Safely

The concert marimba is a large and heavy instrument that gets used in various places by persons of all ages, so please obey the following instructions regarding their regular care and placement. Especially in the case of children, a responsible adult should provide proper instruction on how to use and treat the marimba before use.

Preventing Injuries —Make sure that all precautions described below are obeyed—

About the Icons

Icons are used in this section to promote the safe use of this product, and to prevent you and others from harm and property damage. Please fully understand the meaning of the icons before reading the manual.



This icon urges you to pay caution (includes dangers and warnings).



This icon indicates actions that are prohibited. For example: Do not disassemble.



This icon indicates special instructions that should be strictly followed.



Warning

Disregard of the warnings with this mark or misuse may result in death or personal injury.



Before you use the concert marimba, carefully read the instructions listed below and the owner's manual.

Cautions when setting the instrument.



Never place the instrument on an sloping, unstable, etc., platform. The instrument may fall or overturn and result in injury.

Cautions for treatment of the instrument.



Never lean on or climb onto the instrument. The instrument may fall and result in injury.

Do not play or roughhouse around the instrument. Bumping into the instrument may result in injury. It may also cause instrument may also fall over. Keep children away from the instrument.



If an earthquake occurs, strong shocks caused by the earthquake may overturn the instrument or cause it to move about. Stay away from the instrument during earthquakes.

Cautions when moving the instrument.



When moving the instrument on its casters, only move across smooth, flat surfaces. Hold the instrument by its frame end and push forward slowly.

When moving the instrument on its casters.

1. Avoid moving the instrument across surfaces that are sloped, uneven, or graveled. The concert marimba can collapse and/or get out of control.
2. Do not run with the instrument. The instrument may become impossible to stop, crash into a wall, and cause serious injury.
3. If the instrument must be lifted, do so with at least two (2) persons. Lift the instrument by its frame ends using both hands. Holding the rail section can result in the instrument dropping or falling off. Never hold the instrument anywhere other than the frame ends.

Hold the instrument by the frame end and push forward slowly.

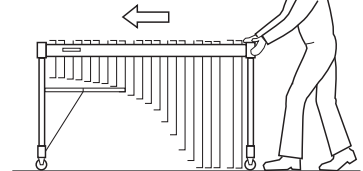

Moving the instrument up or down stairs should never be done with the instrument assembled. Doing so is a danger as parts can fall off, or you can lose balance causing the instrument to fall over. Only move the instrument after it has been disassembled.



Caution

Injury or handicaps to persons caused by the disregard of warnings with this mark or, misuse of the instrument, may result in the loss of personal property.



Please change cracked tone bars as soon as possible. Cracked tone bars have sharp edges that can cut hands.



If the instrument is often moved, bolts, parts, etc., may become loose. After moving the instrument, check and make sure all bolts, parts, etc., are firmly fastened. Firmly tighten all loose items.



Do not use the hammer for anything other than playing the instrument. It may be the cause of injury or accidents. Do not let children strike other, etc., with the mallet. Do not allow such dangerous behavior to take place.



When assembling, be careful not to pinch your fingers or hands. Take special care when assembling rails and resonator pipes. Two persons should carry out this part of the assembly, double-checking as the assembly proceeds.

PRECAUTIONS FOR HANDLING GAS SPRING

Please observe the following instructions for proper handling of the gas spring.

1. Precautions for handling the gas spring



Caution



This gas spring requires no oil supply to its sliding section. Additional oil will reduce the sealing durability and cause the oil to leak.



Note that a nick on the piston rod or cylinder will shorten the service life of the sealing or cause a malfunction.



Never apply any impact to the gas spring. It will cause oil leakage, malfunction or breakage.



Do not expose the gas spring to an excessively high or low temperature. The allowable temperature range for use is -20°C to 80°C.



Never disassemble the gas spring. As a high pressure gas is sealed in it, disassembling it will cause a high risk.



Avoid using the instrument where it is exposed to rain, water or much dust.



Note that there is not much rigidity in the bending direction. Depending on accuracy in its installation, the bending load will cause the rod to bend, resulting in malfunction.



Do not apply an excessive force to lift the frame end and pull off the gas spring from the leg.

- Do not apply a high tensile load to the gas spring as it will cause damage to the gas spring.
- In the event of a failure, stop using the instrument and contact the shop of its purchase. If your dealer is unable to assist you, please contact Yamaha directly.

2. Instructions for discarding the gas spring



Danger

Make sure to observe the following instructions when discarding the gas spring.

As pressurized nitrogen gas is sealed in the gas spring, be sure to release before discarding it. Or an explosion may occur, causing an injury.

[PRECAUTIONS]

- Do not crash.
- Do not cut.
- Do not make a hole anywhere other than the specified positions (① and ② in the Fig.1).
- Do not throw it in the fire.

[Discarding procedure]

- Put the gas spring in a plastic bag. Using a drill of 2 to 3 mm, make a hole ① from outside of the plastic bag at the position as specified in the figure to release the gas and oil and then make a hole ② at the position as specified. (Be sure to make holes in the order of ① and ②.)
- If a vinyl bag is not used, the oil and drill chips will spread. (In such a case, wear eye protection glasses.)

Fig. 1

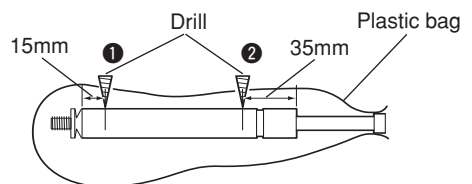

* Drill 2 holes as shown above to release the gas before discarding the gas spring.

Précautions à observer

Pour une utilisation sûre du Marimba de concert

Le Marimba de concert est un instrument grand et lourd qui peut être utilisé dans différents lieux par des personnes de tous âges ; il est donc important que vous respectiez les instructions de placement et de manipulation ci-dessous. Dans les cas où des enfants doivent utiliser l'instrument, un adulte responsable doit leur expliquer comment utiliser et manipuler le marimba avant de les laisser s'en servir.

Pour éviter toute blessure — Veuillez lire toutes les précautions d'utilisation ci-dessous —



Des icônes sont utilisées dans cette section pour rendre plus claires les instructions de sécurité permettant d'éviter les risques de blessure et de dégâts matériels. Veuillez bien lire les consignes et comprendre le sens de chaque icône avant de lire le reste de ce mode d'emploi.



Cette icône vous recommande d'être attentif (et peut signaler des dangers et avertissements)



Cette icône signale des actions interdites.



Exemple : Ne pas démonter.



Cette icône signale des instructions spéciales qui doivent absolument être suivies.



Avertissement

Si vous négligez les avertissements signalés par ce symbole, il peut en résulter mort d'homme ou blessures.



Avant d'utiliser le Marimba de concert, lisez attentivement les instructions ci-dessous et l'intégralité de ce mode d'emploi.

Précautions d'installation de l'instrument



Ne placez en aucun cas l'instrument sur un plan incliné ou instable. Il pourrait tomber ou se retourner et blesser quelqu'un.

Précautions de traitement de l'instrument



Ne vous appuyez pas et ne montez pas sur l'instrument. Il pourrait tomber et blesser quelqu'un.

Ne jouez pas, ne soyez pas turbulent à proximité de l'instrument. Vous pourriez vous y cogner et vous blesser. L'instrument pourrait également tomber. Éloignez les enfants de l'instrument.



Si un tremblement de terre se produit, les fortes vibrations occasionnées pourraient renverser l'instrument ou entraîner son déplacement. Éloignez-vous de l'instrument pendant les tremblements de terre.

Précautions de déplacement de l'instrument



Lorsque vous déplacez l'instrument en le faisant rouler sur ses roulettes, **ne le déplacez que sur des surfaces planes et lisses**. Tenez l'instrument par son châssis et poussez doucement.

Lorsque vous déplacez l'instrument sur ses **roulettes** :

1. Évitez de le faire passer sur des surfaces en pente, inégales ou sur du gravier. Il pourrait s'effondrer ou vous échapper.
2. Ne courez pas avec l'instrument. Ce dernier pourrait devenir impossible à arrêter, heurter un mur et être à l'origine de blessures graves.
3. Si l'instrument doit être soulevé, deux (2) personnes au moins sont nécessaires. Soulevez l'instrument par les extrémités du châssis et en utilisant les deux mains. Si vous essayez de le tenir par la section des rails, vous risquez de le renverser ou de le faire tomber. Ne tentez pas de soutenir l'instrument par une partie autre que les extrémités du châssis.

Tenez l'instrument par son cadre et poussez doucement

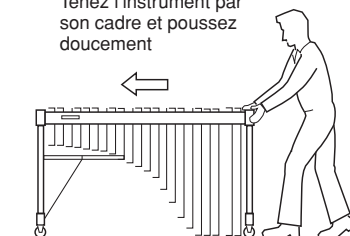

Ne montez ni descendez jamais d'escalier avec l'instrument tout monté. Ce serait très dangereux car des pièces peuvent tomber ou bien vous pouvez perdre l'équilibre et l'instrument peut tomber voire dégringoler les escaliers. Dans un tel cas, démontez l'instrument avant de le déplacer.



Attention

Si vous négligez les avertissements signalés par ce symbole, vous pourriez infliger des blessures ou des handicaps à des personnes ou causer la perte de biens matériels.



Veuillez remplacer au plus vite les lames abîmées. Ces dernières peuvent avoir des bords effilés et coupants.



Si l'instrument est souvent déplacé, les boulons et autres pièces peuvent se desserrer, ce qui peut entraîner accidents et blessures. Après déplacement de l'instrument, assurez-vous que tous les boulons et pièces sont encore bien serrés. Si ce n'est pas le cas, resserrez les pièces qui en ont besoin.



N'utilisez les baguettes que pour jouer sur l'instrument.

Dans le cas contraire, vous pourriez provoquer des blessures ou un accident. Veillez à ce que les enfants ne jouent pas avec les baguettes, en particulier pour frapper d'autres enfants, etc., car cela peut être dangereux.



Lors du montage de l'instrument, veillez à ne pas vous coincer les doigts ou les mains. Faites particulièrement attention lors du montage des rails et des résonateurs. Il faut être deux pour effectuer cette partie du montage, avec contrôle systématique par l'une ou l'autre personne.

PRECAUTIONS

Please read the following instructions carefully before using your marimbas.

◆ Installation Location

Use or storage in the following locations may cause damage, even when packaged.

- In direct sunlight, such as near a window, or in a closed vehicle in daytime.
- Near heating devices or in other locations subject to excessive heat.
- In excessively cold environment.
- In places with excessive humidity or dust.
- Locations subject to vibrations.

◆ Handling

- Never place an object on or lean against the instrument, as this may cause damage to the tone bars and frame parts or topple the instrument, which is extremely dangerous.
- Do not use hand orchestra bell mallets or other hard objects on your marimbas. The resulting dents or scratches in the tone bars could impair the sound.

◆ Moving and Transporting the Instrument

- Before moving the instrument, make sure that the caster brakes are released. Also make sure to lift the instrument slightly when moving over rough surfaces.
- When the instrument must be transported to a different location, disassemble it to the same state as when it was purchased (See page 21.), taking care to pack each component properly. Disassembly steps are in the opposite order of assembly.

◆ When Not in Use

- Always engage the caster brakes.

◆ Maintenance

- The tone bars should be polished from time to time using a soft and dry cloth or silicone cloth. Stains that cannot be removed with a dry cloth may be wiped off using a small amount of ethyl alcohol. Never use thinner or benzene or a wet cloth for cleaning purposes.

◆ Keep This Manual for Future Reference

- After reading, make sure to keep the manual in a safe place.

Assembly Cautions

- When assembling/disassembling the instrument, do so with at least two persons and follow the instructions outlined in this manual. Assembly in the wrong order can cause the pipes to drop which may result in an injury, impair the performance functionality of the instrument or cause noise.
- After final adjustment of the legs the fixing screws must be tightened securely to prevent loosening. Looseness may cause the instrument to shift during performance and can also cause noise and other problems. Retighten the screws from time to time.

Thank you for purchasing the YAMAHA concert marimbas. We, at YAMAHA, aiming principally at beautiful sounds and playing ease, have made strenuous efforts in creating the outstanding instruments and selecting high quality materials, and successfully developed these marimbas. We are convinced that you will enjoy playing your instrument that produces spreading and yet deep sounds as well as rich volume to your content. This manual describes proper use of YAMAHA concert marimbas. Please read it thoroughly to ensure that your instrument will give you enjoyment for a long time.

NOMENCLATURE

■ YM-5104A/5100A/4900A/4600A

* The illustration shows model YM-5100A.

* The YM-5100A is used for illustrative purposes in this manual. For this reason, the illustrations may not match with the YM-5104A, YM-4900A, and YM-4600A.

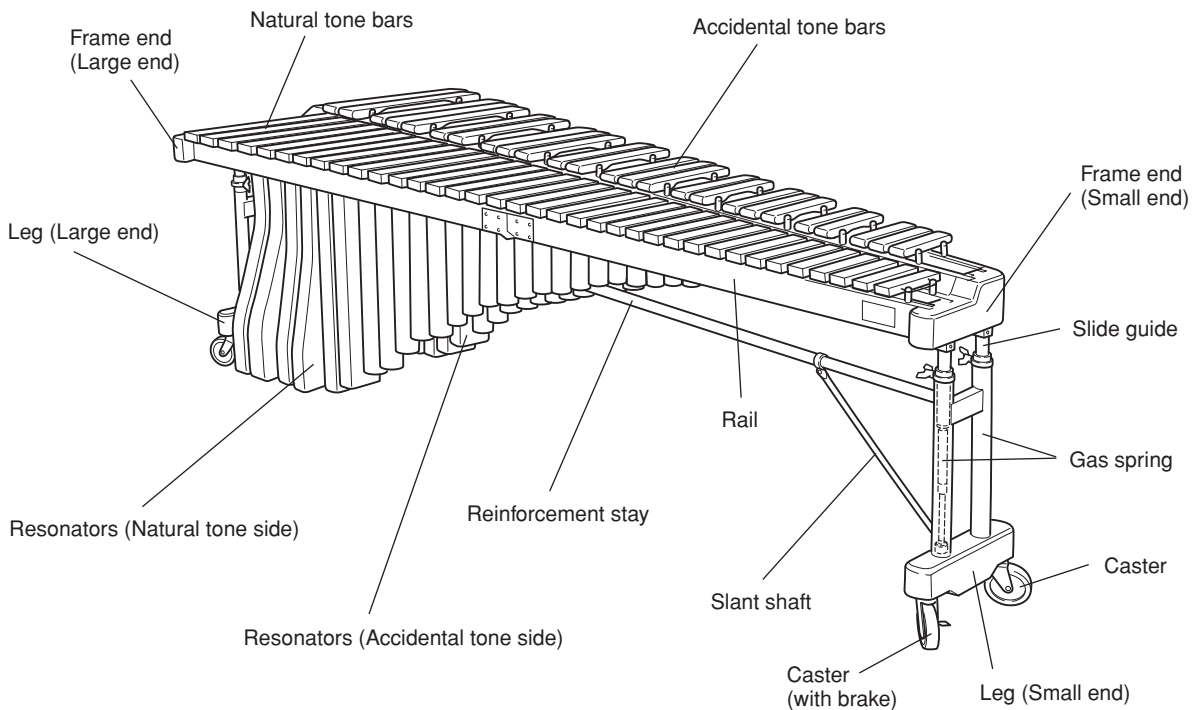

CONFIRMATION OF PACKING CONTENTS

The shipping carton of your marimba should contain the parts shown below. Before assembling the instrument, confirm that all parts are included as listed.

* In the event that a part is missing, please contact the shop where the instrument was purchased.

① **Natural tone bars**

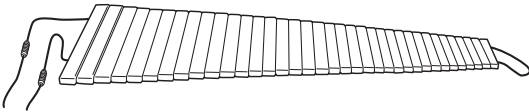

② **Accidental tone bars**

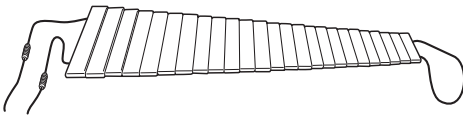

③ **Resonators (Natural tone side)**

Resonance Regulator: G²³, A²⁵
(YM-5104A, YM-5100A, YM-4900A only)

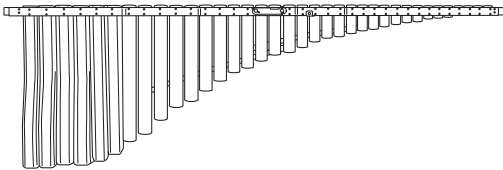

④ **Resonators (Accidental tone side)**

Resonance Regulator: F^{#22}, G^{#24}, A^{#26}
(YM-5104A, YM-5100A, YM-4900A only)

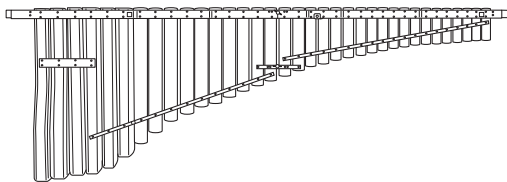

⑤ **Reinforcement stay**

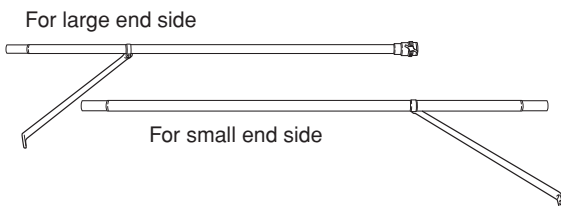

⑥ **Rail (1)**

Marking on the end face (A).

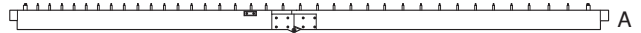

⑦ **Rail (2)**

Marking on the end face (B).

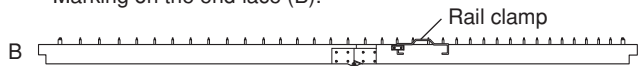

⑧ **Rail (3)**

Marking on the end face (C).

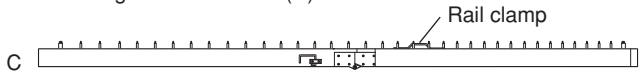

⑨ **Rail (4)**

Marking on the end face (D).

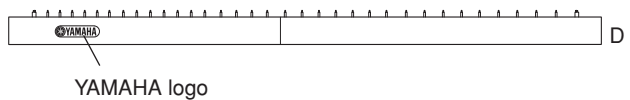

⑩ **Leg (Large end)**

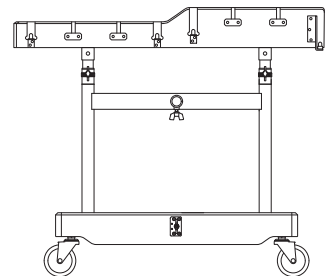

⑪ **Leg (Small end)**

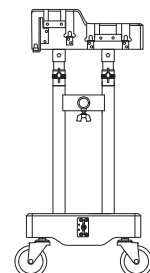

ASSEMBLY

For safety, the instrument should be assembled by at least two persons in a location with sufficient space.

We recommend to you to assemble the instrument on a soft rug or carpet.

1 Connect the large and the small end legs using the reinforcement stays.

** Before proceeding to the next step, make sure that the slide guide fixing bolts of the large and small end legs are securely fastened.*

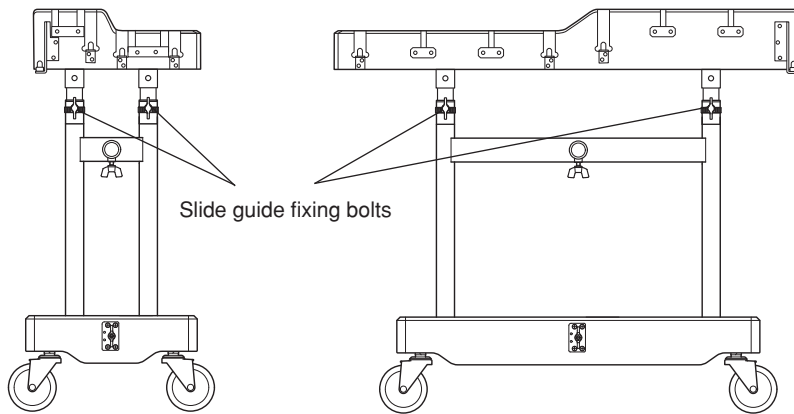
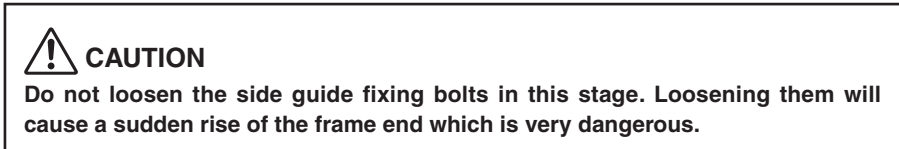

1-1. Place the large and small end legs and reinforcement stays so that they will be positioned as illustrated below after assembly.

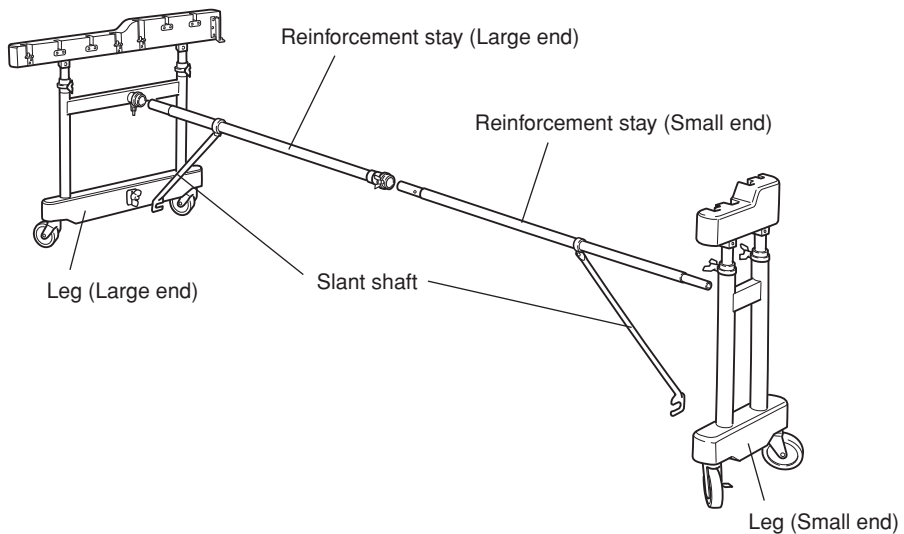

- 1-2. Connect the reinforcement stays at the center. Align the end of the fixing bolt and the holes in the reinforcement stays and tighten the fixing bolt securely.

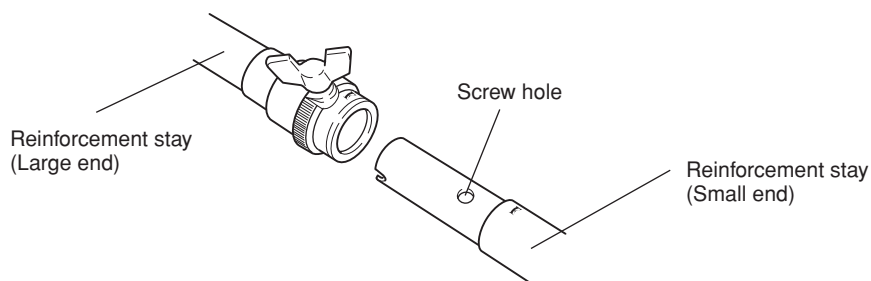

- 1-3. Install the reinforcement stay to the large end leg. Insert the "E" marked end of the reinforcement stay (with its slant shaft facing down) into the joint (marked with "E") on the large end leg until it stops and tighten the fixing bolt securely. In the same way, install the reinforcement stay to the small end leg. (There is no marking on the small end joint.)

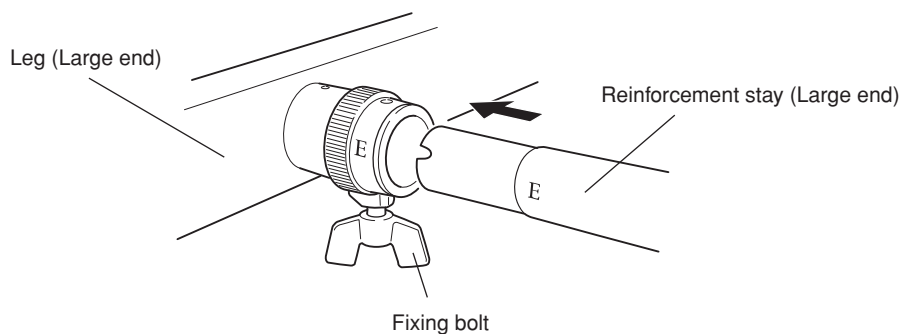

- 1-4. After making sure that both legs are perpendicular to the floor, fit the end of each slant shaft to the wing nut located in the lower part of each leg and tighten it securely.

** Make sure that the slant shaft is securely fitted.*

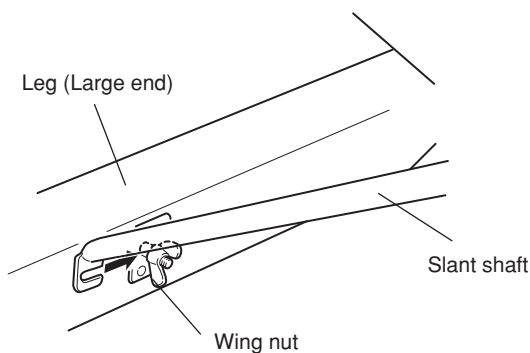

2 Insert the rails (2) and (3) into the end frames of the legs.

2-1. First, insert the rail (2).

A mark "B" is printed on the big end face of the rail (2) and the groove section of the end frame of the big end leg.

** Do not insert one side of the rail all the way down first, but push both sides into grooves alternately little by little until both sides are inserted fully and stop.*

Next, in the same way, insert the rail (3) securely.

A mark "C" is printed on the big end face of the rail (3) and the groove section of the end frame of the big end leg.

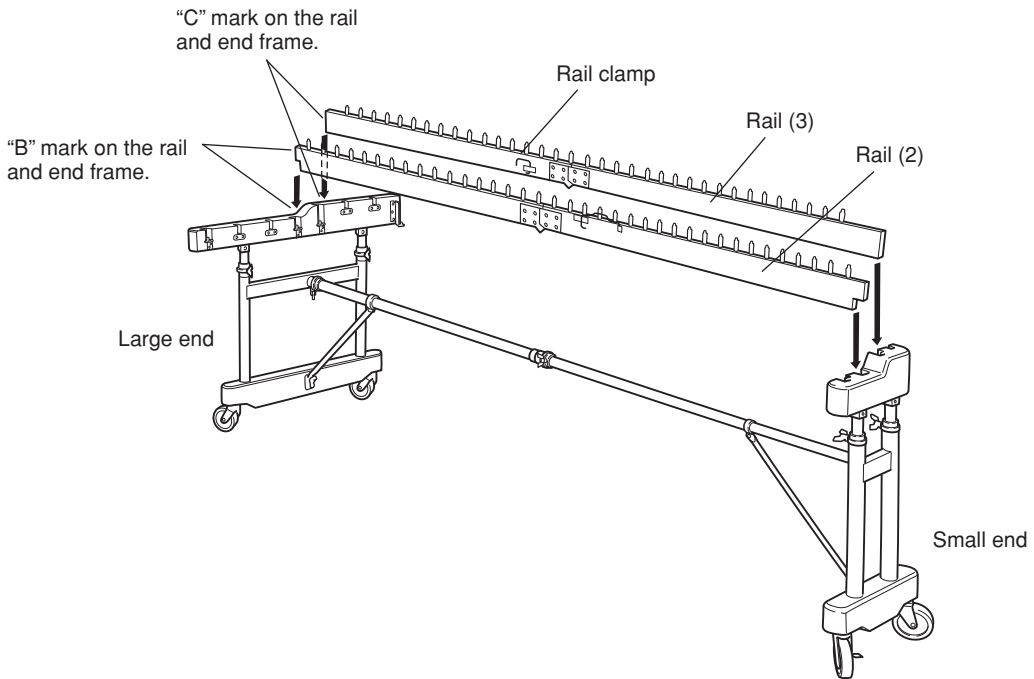

2-2. Engage the short rail clamp located at the center of the rail (3) with the rail (2).

** Release the clamp from its holder, lift and move it to the rail (2) and push it down fully.*

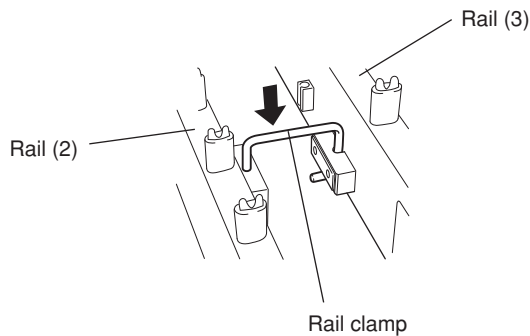

3 Attach the resonators.

3-1. Unbend the resonators, apply a hook and tighten the wing nut securely.

When assembling the resonator pipes, make sure that the washer is positioned on the outer side of the hook as shown in the illustration below.

* *Positioning the washer on the inner side of the hook can result in noise while playing.*

* *All the natural tone resonators are closed at the bottom.*

* *When assembling the resonators, use care not cause any damage to them.*

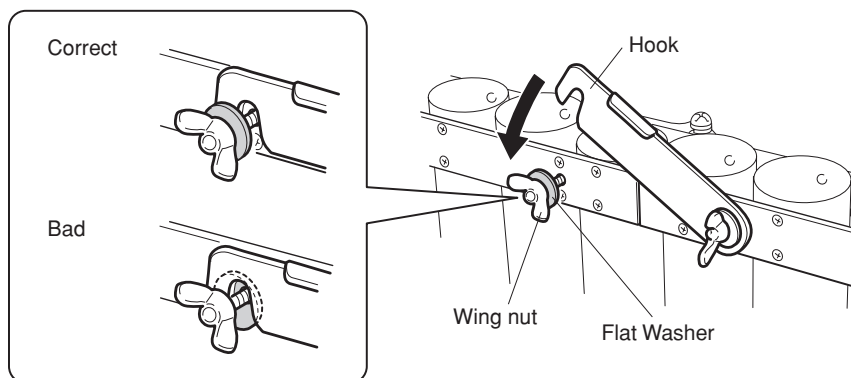

3-2. Insert the resonators into the resonator holders on the end frames in the same way as the rails.

* *Make sure not to confuse the natural tone resonators and accidental tone resonators.*

* *Take care not to bump the resonators against the legs, etc.*

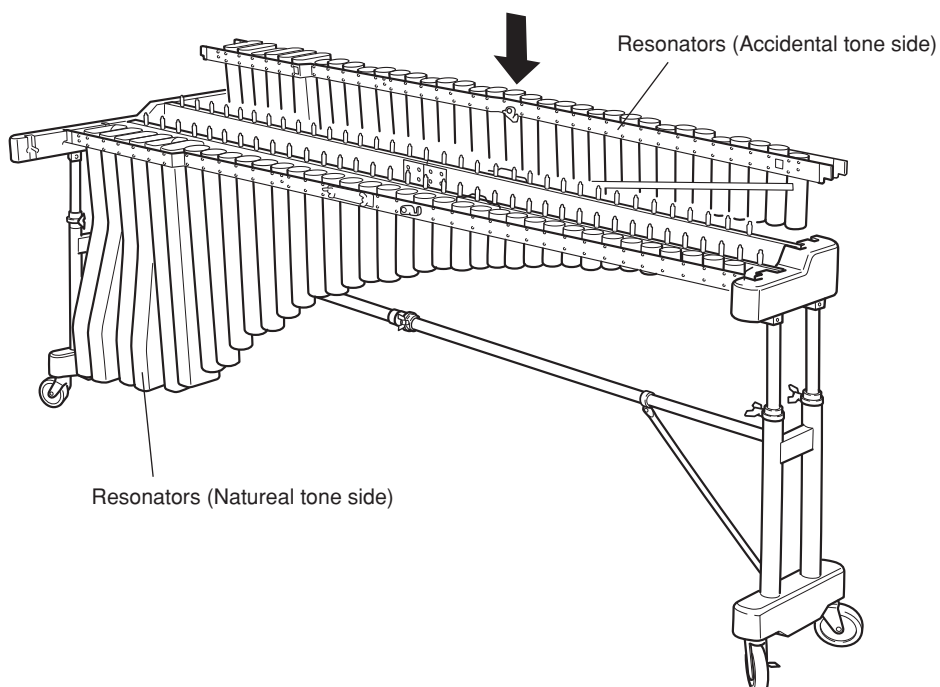

4 Insert the rails (1) and (4) into the end frames of the legs.

4-1. Insert the outer rails (1) and (4) in the same way as the inner rails (2) and (3).

A mark "A" is printed on the big end face of the rail (1) and the groove section of the end frame of the big end leg, and a mark "D" for the rail (4).

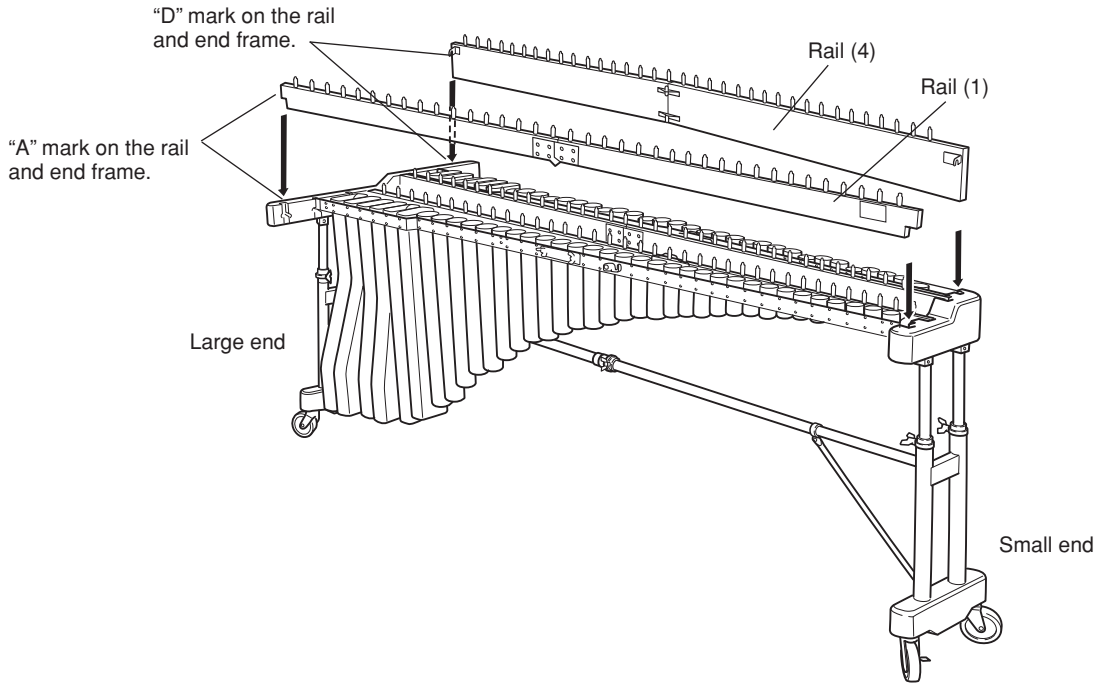

4-2. Engage the rail clamps on rail (2) and rail (3) with rail (1) and rail (4) respectively.

YM-5104A/5100A Only

4-3. Secure the resonators by fitting their hooks to the rail clamps engaged in Step 4-2.

- * Hooks are provided at 2 locations both on the natural tone side and the accidental tone side.
- * Make sure that each hook is securely fitted.

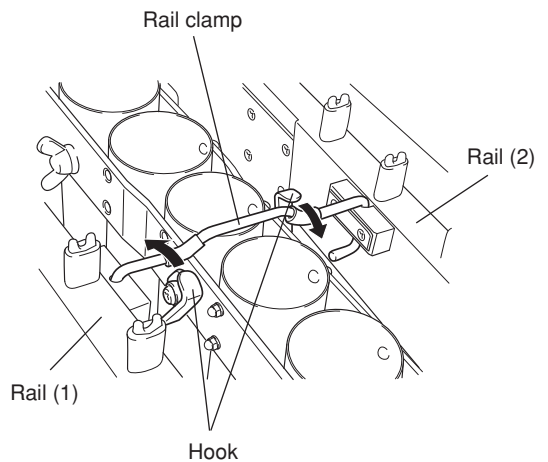

5 Set the tone bars.

5-1. Set the natural tone bars first.

With one person holding the suspension cords on the bass side and the other holding the suspension cords on the treble side securely with both hands, gently place the tone bars on the rails. Align each tone bar individually and hook its cord onto the corresponding post. After confirming that the cord is secured to every post, fix the tone bars by pulling the right and left cords forward from the large end side and hooking the two springs into each other.

* When setting the tone bars, use care not to cause any damage to them.

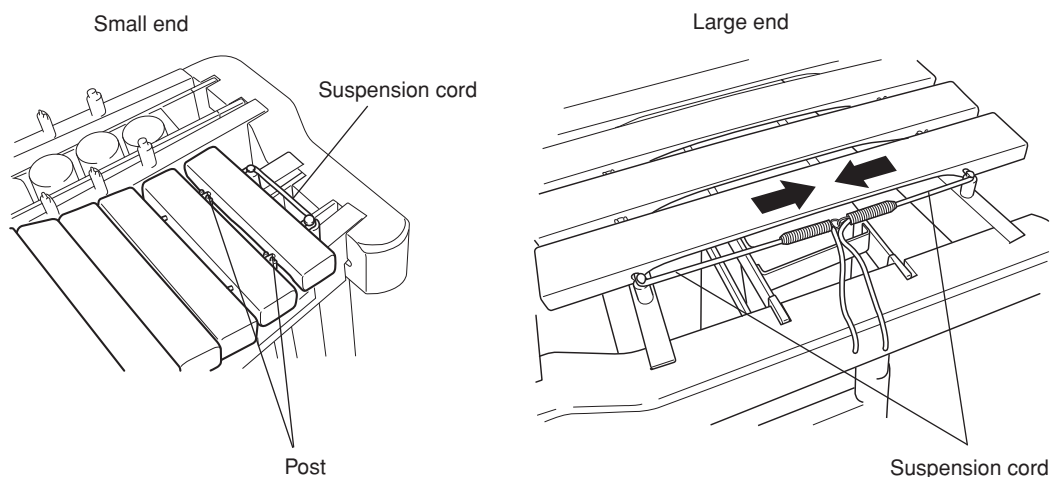

YM-5104A/5100A/4900A Only

5-2. Each of F#²², G²³, G#²⁴, A²⁵ and A#²⁶ resonators has a resonance regulator. While tapping each tone bar, move the resonance regulator to find the position where the best resonance is obtained and fix it there.

* When fixing the resonance regulator, check to ensure that it is not aslant.

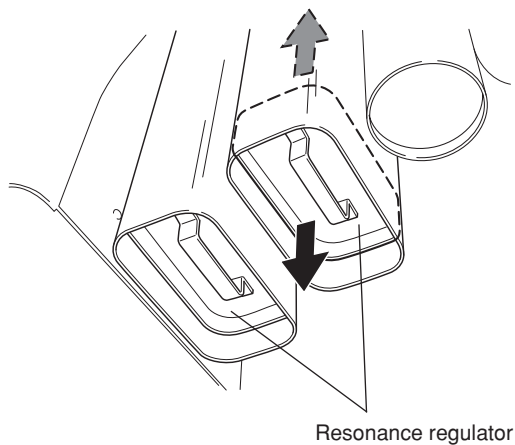

YM-4600A Only

5-2. As YM-4600A does not have a resonance regulator, insert resonators into resonator holders as shown below.

* The resonators are factory adjusted so that the optimum resonance level is obtained at 23°C. If desirable resonance is not available due to the temperature lower or higher than 23°C, adjust setting of the resonators. Move the resonators to fit into longer grooves when the temperature is higher and into shorter grooves when the temperature is lower.

Temperature	Grooves to use
Higher	Short groove ("A" in the figure right)
Around 23°C	Center groove ("B")
Lower	Long groove ("C")

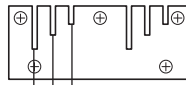

A : For a higher temperature
 B : For a temperature around 23°C
 C : For a lower temperature

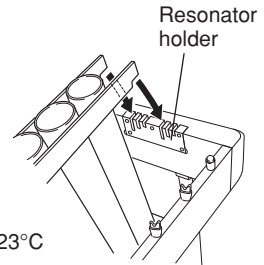

6 Adjust the height of the tone bars.

While supporting the frame end of the leg by hand, loosen the fixing bolt of the slide guide on both large end and small end sides.

Adjust the height to the desired level and tighten the fixing bolts securely.

When adjusting the height, use the lines on the slide guide for reference and make the tone bars in parallel with the floor surface.

Upon completion of assembly, check to make sure that each bolt is tightened securely.

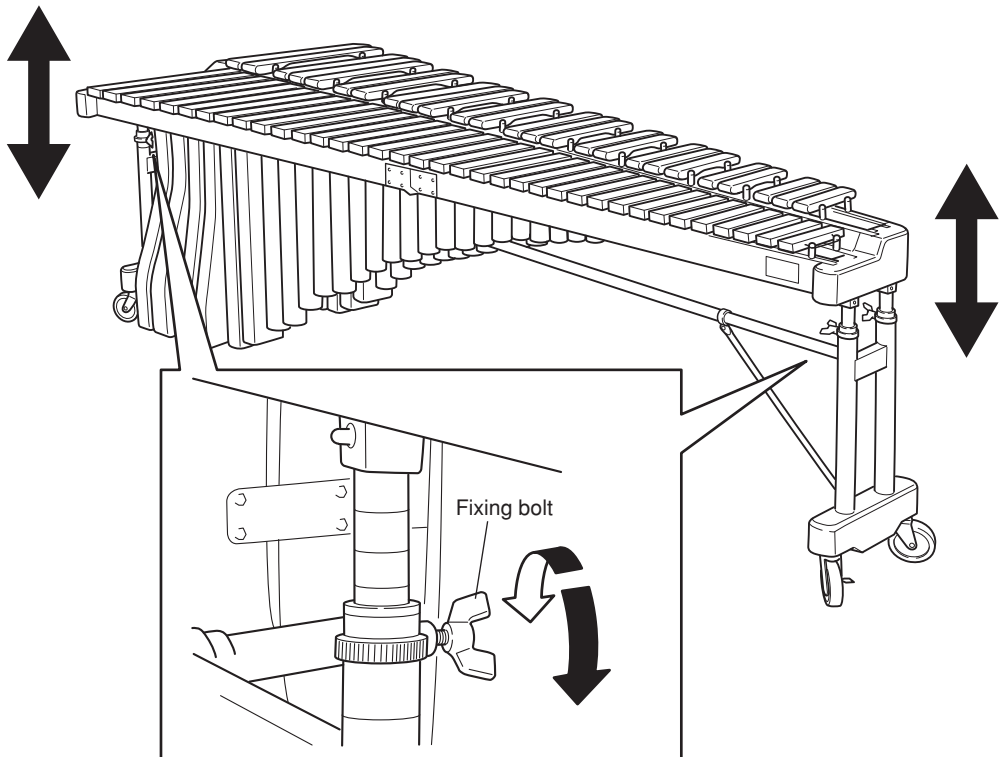

SPECIFICATIONS/SCALE RANGE

■ YM-5104A

- **Range:** C16 – G83 (5-1/2 octave)
- **Bars:** Rosewood
- **Bar sizes:**
 - 72 – 41 mm (2.8" – 1.6") wide
 - 24 – 20 mm (0.94" – 0.79") thick
- **Resonator:** Helmholtz, Elliptic low sound resonator
- **Height Adjustment:**
 - Gas spring system
 - 15 cm (86 – 101 cm)
 - 5.9" (33.9" – 39.8")
- **Dimensions (W x D):** 281 x 103 cm (110.6" x 40.6")
- **Weight:** 99 kg (218 lbs 4 oz)

■ YM-5100A

- **Range:** C16 – C76 (5 octave)
- **Bars:** Rosewood
- **Bar sizes:**
 - 72 – 41 mm (2.8" – 1.6") wide
 - 24 – 20 mm (0.94" – 0.79") thick
- **Resonator:** Helmholtz, Elliptic low sound resonator
- **Height Adjustment:**
 - Gas spring system
 - 15 cm (86 – 101 cm)
 - 5.9" (33.9" – 39.8")
- **Dimensions (W x D):** 261 x 103 cm (102.8" x 40.6")
- **Weight:** 96 kg (211 lbs 10 oz)

■ YM-4900A

- **Range:** F21 – C76 (4-1/2 octave)
- **Bars:** Rosewood
- **Bar sizes:**
 - 65 – 41 mm (2.5" – 1.6") wide
 - 24 – 20 mm (0.94" – 0.79") thick
- **Resonator:** Helmholtz, Elliptic low sound resonator
- **Height Adjustment:**
 - Gas spring system
 - 15 cm (86 – 101 cm)
 - 5.9" (33.9" – 39.8")
- **Dimensions (W x D):** 235 x 96 cm (92.5" x 37.8")
- **Weight:** 78 kg (171 lbs 15 oz)

■ YM-4600A

- **Range:** A25 – C76 (4-1/3 octave)
- **Bars:** Rosewood
- **Bar sizes:**
 - 65 – 41 mm (2.5" – 1.6") wide
 - 24 – 20 mm (0.94" – 0.79") thick
- **Resonator:** Circle resonator
- **Height Adjustment:**
 - Gas spring system
 - 15 cm (86 – 101 cm)
 - 5.9" (33.9" – 39.8")
- **Dimensions (W x D):** 219 x 91 cm (86.2" x 35.8")
- **Weight:** 68 kg (149 lbs 14 oz)

● SCALE RANGE

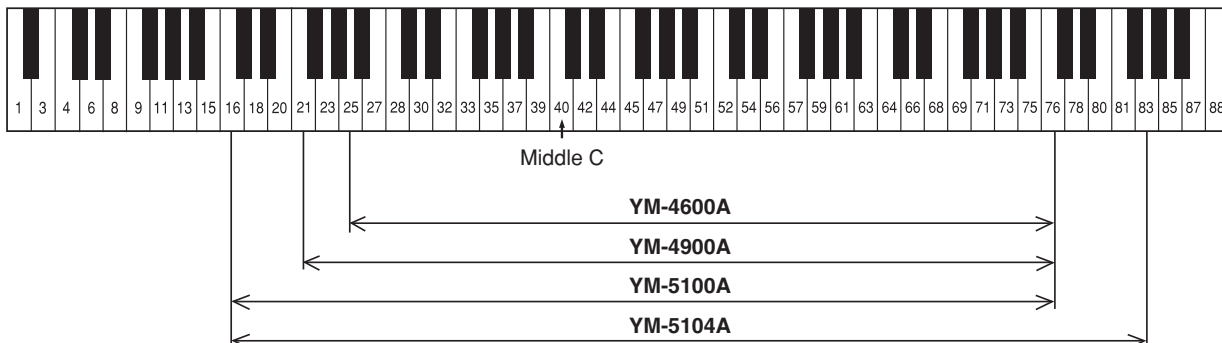

* Specifications subject to change without notice.

