

ABBREVIATIONS FOR THE SERVICE MANUAL

ABBREVIATION	EXPLANATION	ABBREVIATION	EXPLANATION
AMP (Amp)	AMPlifier	MINI	MINImum
BBD	Backet Brigade Diode	MIX	MIXer
BCD	Binary Code Decimal	MOD	MODulation
B.DOWN	Brak Down	M.WHEEL	Modulation WHEEL
B.UP	Back UP	OSC	OSCillator
CE	Chip Enable	RAM	Random Access Memory
CH	CHannel	RD	ReaD
COMP	COMParator	REG	REGulator
CONT	CONTrol	RESO	RESOnance
CV	Control Voltage	RL	ReLay
D/A	Digital to Analogue	ROM	Read Only Memory
EG	Envelope Generator	S/H	Sample and Hold
EXT	EXTernal	SW	SWitch
FREQ	FREQuency	THRU	THRoUgh
HPF	High Pass Filter	TRANS	TRANSpose
INH	INHibit	U	Upper
INT	INTerrupt	VA	Voltage Analog
INV	INVerter	VCA	Voltage Controlled Amplifier
L	Lower	VCF	Voltage Controlled Filter
LFO	Low Frequency Oscillator	VR	Variable Resistor
MAX	MAXimum	VREF	REFerence Voltage
MEMO	MEMOry	WR	WRite
MIDI	Musical Instrument Digital Interface		

SAFETY INSTRUCTION

SAFETY CHECK AFTER SERVICING

Confirm the specified insulation resistance between power cord plug prongs and externally exposed parts of the set is greater than 10 Mohms, but for equipment with external antenna terminals (tuner, receiver, etc.) and is intended for **C** or **A**, specified insulation resistance should be more than 2.2 Mohms (ground terminals, microphone jacks, headphone jacks, line-in-out jacks etc.)

PRECAUTIONS DURING SERVICING

1. Parts identified by the Δ symbol parts are critical for safety.
Replace only with parts number specified.
2. In addition to safety, other parts and assemblies are specified for conformance with such regulations as those applying to spurious radiation. These must also be replaced only with specified replacements.
Examples: RF converters, tuner units, antenna selector switches, RF cables, noise blocking capacitors, noise blocking filters, etc.
3. Use specified internal wiring. Note especially:
 - 1) Wires covered with PVC tubing
 - 2) Double insulated wires
 - 3) High voltage leads
4. Use specified insulating materials for hazardous live parts. Note especially:
 - 1) Insulation Tape
 - 2) PVC tubing
 - 3) Spacers (Insulating Barriers)
 - 4) Insulation sheets for transistors
 - 5) Plastic screws for fixing microswitch (especially in turntable)
5. When replacing AC primary side components (transformers, power cords, noise blocking capacitors, etc.), wrap ends of wires securely about the terminals before soldering.

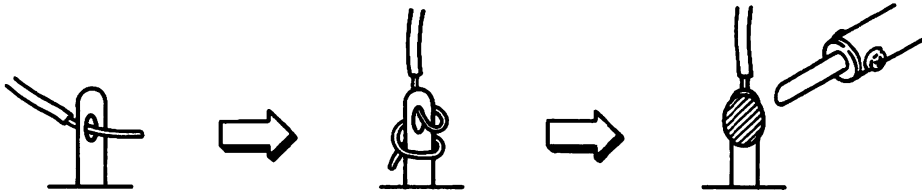

6. Observe that wires do not contact heat producing parts (heatsinks, oxide metal film resistors, fusible resistors, etc.).
7. Check that replaced wires do not contact sharp edged or pointed parts.
8. Also check areas surrounding repaired locations.
9. Use care that foreign objects (screws, solder droplets, etc.) do not remain inside the set.
10. The LITHIUM BATTERY employed for memory back up has an explosive probability when the battery itself is excessive heated.
Normally, LITHIUM BATTERY is not necessary to replace, because the life of LITHIUM BATTERY is about 10 years.

IN CASE OF REPLACING: RESOLDER AND SOLDER AS RECOMMENDED WAY.



Recommended way

VOLTAGE CONVERSION

Models for Canada, USA and Japan are not equipped with this facility. Each machine is preset at the factory according to its destination, but some machines can be set to 220V or 240V as required.

If the machine's Voltage can be converted:

Before connecting the power cord, set the VOLTAGE SELECTOR on the bottom panel for the correct Voltage is indicated.

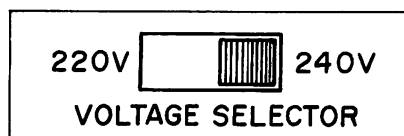

SECTION 1

SERVICE MANUAL

TABLE OF CONTENTS

I. SPECIFICATIONS	4
II. DISMANTLING OF UNIT	5
1. HOW TO OPEN THE FRONT PANEL.....	5
2. HOW TO DISMANTLE THE KEYBOARD.....	5
3. HOW TO DISMANTLE THE BEND PANEL BLOCK	5
III. CONTROLS	6
IV. THE KEYBOARD REACTION-SHIP TO EQUALLY TEMPERED SCALE FREQUENCIES AND MUSICAL-NOTATION	7
V. PRINCIPAL PARTS LOCATION.....	7
VI. ADJUSTMENT.....	8
1. BALANCE OF $\pm 6V$ ON THE POWER SUPPLY PC BOARD	8
2. OFF-SET OF FINAL VCA ON THE VOICE PC BOARD	8
3. BALANCE OF BBD OUTPUT ON THE CHORUS PC BOARD.....	9
4. OFF-SET OF IC6 (LF 356) ON THE CPU PC BOARD.....	9
VII. PC BOARD TITLES AND IDENTIFICATION NUMBERS	10
VIII. MIDI IMPLEMENTATION CHART.....	10

This Manual is FOR INTERNAL USE ONLY and must not be made available to unauthorized personal. No part of this manual may be reproduced in any form without permission from AKAI-ELECTRIC CO., LTD., Tokyo, Japan.

I. SPECIFICATIONS

MODEL AX60

Key	61 key 5 octave C scale (Split keyboard)
Voice	6 voice
Tone generator	VCO (voltage controlled oscillator)
Internal memory	64 sound programs (8 banks of 8 programs) 8 split preset
External memory	Cassette interface
PARAMETERS LFO section	LFO select (VCO, VCF, VCA) Waveform (▽ , ▲ , △ , ▭ , RND) Depth control Speed control Delay control
VCO section	Octave (2', 4', 8', 16', 32') Waveform (▲ , △ , ▭ , △ + ▲) Pulse width control Speed control EG depth control Sampler ON/OFF Noise ON/OFF A-B Balance control
VCF section	Cut off frequency control Resonance control Key follow control VCO MOD control HPF control EG polarity +/-
Envelope generator section	Attack control Decay control Sustain control Release control Depth level control EG destinations (VCF EG, VCA EG, VCA GATE)
Function	Master level control Master tune control (± 50 cent) Auto tune ON/OFF Split ON/OFF Split mode (0-6, 2-4, 4-2, 6-0) Split balance control Chorus (1, 2, off) Arpeggio ON/OFF Arpeggio (5 mode) Arpeggio hold ON/OFF Arpeggio speed control Unison (upper, lower, off) Wheel (upper, lower) Key transpose ON/OFF Edit recall ON/OFF Compare ON/OFF Write Set MIDI (1 to 16 ch) Memory protect ON/OFF

Wheel	Pitch bend/cut off frequency wheel Pitch bend range control Modulation wheel, Modulation depth control
External jacks	MIDI (IN, OUT, THRU) Tape (load/in, save/out) Sampler input (13 pin/DIN) Sustain pedal jack Arpeggio EXT sync jack Audio output (U/L MIX/Left, Right) Headphone jack
Dimensions	1000 (W) x 110 (H) x 346 (D) mm (39.4 x 4.3 x 13.6 inches)
Weight	11 kg (24.2 lbs)

* For improvement purposes, specifications and design are subject to change without prior notice.

II. DISMANTLING OF UNIT

In case of trouble, etc. necessitating dismantling, please dismantle in the order shown in the photographs. Reassemble in reverse order.

2-1. HOW TO OPEN THE FRONT PANEL (Refer to Fig. 2-1)

1) Remove 8 screws as shown Fig. 2-1, and open the Front Panel as shown Fig. 2-3.

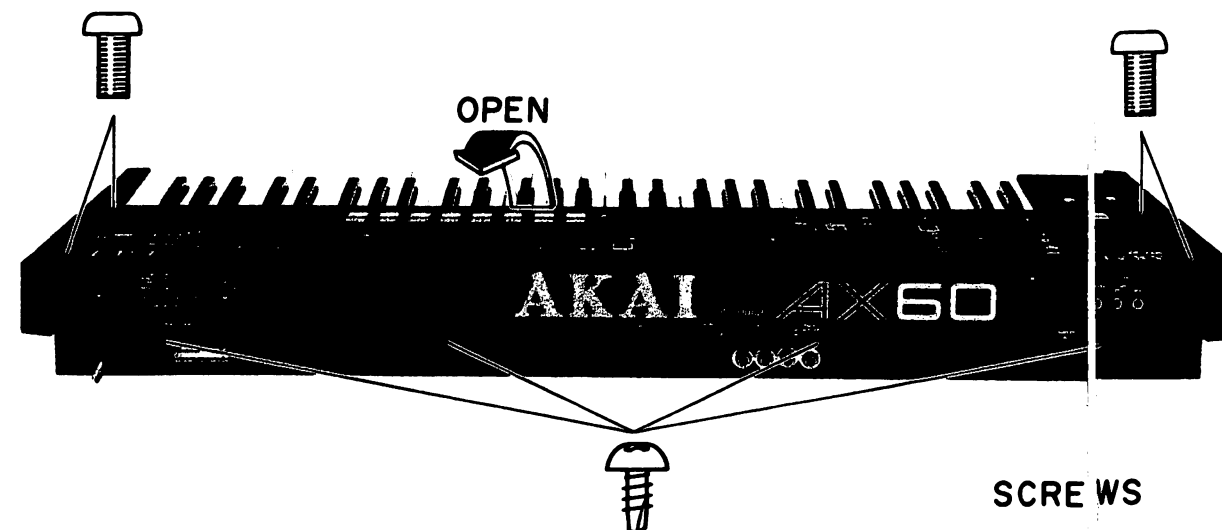

Fig. 2-1

2-2. HOW TO DISMANTLE THE KEYBOARD (Refer to Fig. 2-2 and Fig. 2-3)

1) Remove 6 screws on the Bottom plate, and disconnect the connectors P1 and P2 on the CPU PC Board.

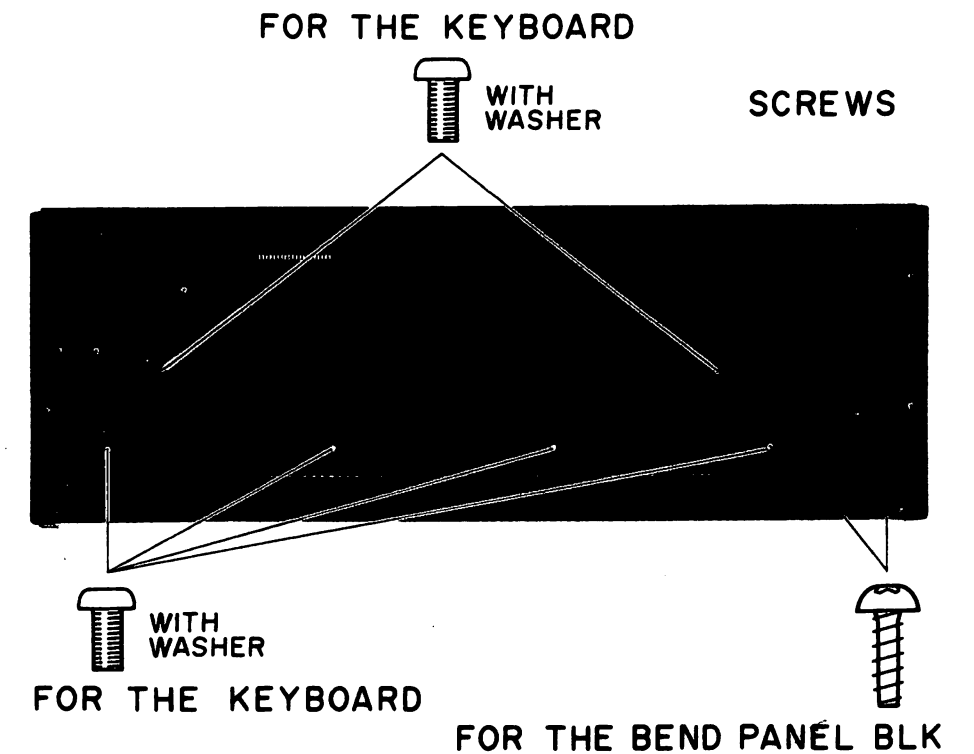

Fig. 2-2

2-3. HOW TO DISMANTLE THE BEND PANEL BLOCK (Refer to Fig. 2-2 and Fig. 2-3)

1) Remove 6 screws as shown Fig. 2-2 and Fig. 2-3, and disconnect the connectors P4, P5 on the CPU PC Board and P1 on the OPERATION (B) PC Board.

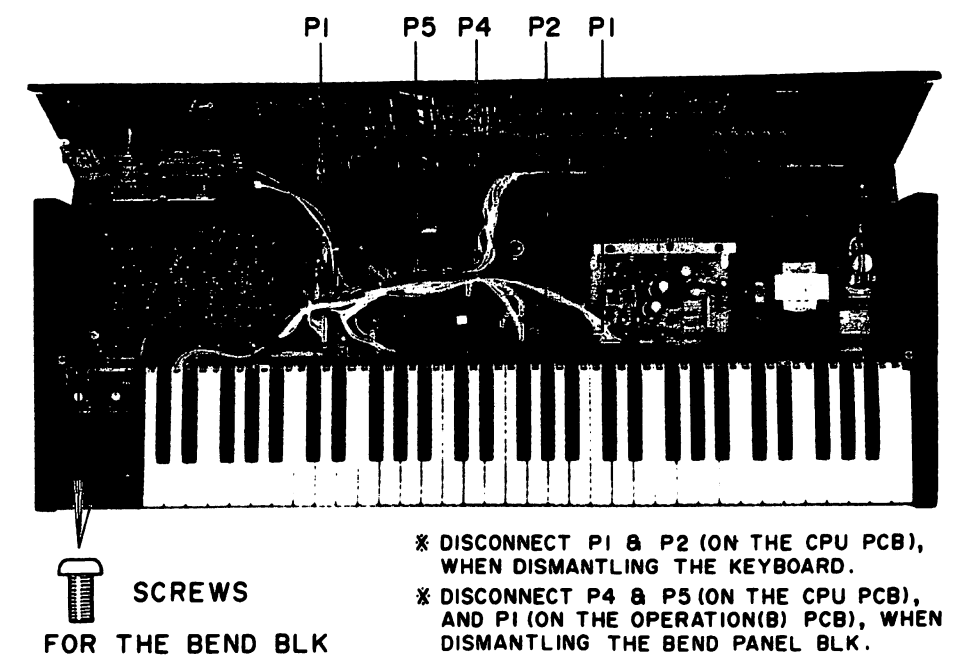

Fig. 2-3

III. CONTROLS

LFO PARAMETER SET-UP KNOBS

DEPTH: Sets the modulation intensity
 SPEED: Sets the modulation frequency.
 DELAY: Sets the amount of time for the modulation to start after pressing a Key.

LFO SELECT BUTTON and INDICATORS
 To select destinations of LFO effect.

LFO WAVEFORM SELECT BUTTON and INDICATORS

CHORUS (1/2/OFF) SELECT BUTTON and INDICATORS
 To select chorus effects or off

ARPEGGIO MODE SELECT BUTTONS and INDICATORS

MODE: To Select 'UP', 'DOWN', 'UP and DOWN'.
 HOLD: To Hold an arpeggiated figure.
 ON/OFF: To turn on or off the arpeggiation effect or function. In whole mode, the entire keyboard is arpeggiated. In 0-6 Split mode, arpeggiation affects the upper split only. In 2-4, 4-2 and 6-0 split modes, arpeggiation affects the lower split only.

OCTAVE SELECT BUTTON and INDICATORS

To set the basic octave range of the keyboard between 2' (highest range) and 32' (lowest range).

VO PARAMETER SET-UP KNOBS

ULSE WIDTH: Acts like a tone control that changes the timbre of each waveform.
 SEED: Controls an LFO frequency that changes the pulse width automatically
 E DEPTH:

(VCO) - B (NOISE/SAMPLER) BALANCE CONTROL KNOB

VCF PARAMETER SET-UP KNOBS

CUT OFF FREQ: To Set a cut off frequency of the VCF (LPF).
 RESONANCE: To boosts the Amplitude of frequencies near the cut off frequency setting.
 KEY FOLLOW: To change the cut off frequency according to the key played (higher or lower note) to maintain the same timbre.
 VCO MOD: To produce musically useful timbre shifts.
 HPF: To set a cut off frequency of the high pass filter.

EG POLARITY SELECT BUTTON and INDICATORS

EG ASSIGNMENT/SELECTION BUTTONS and INDICATORS

EG PARAMETER SET-UP KNOBS

ARPEGGIO SPEED CONTROL KNOB

MASTER LEVEL CONTROL

SPLIT BALANCE LEVEL CONTROL

UNISON MODE SELECT BUTTON and INDICATORS

AUTO TUNE BUTTON

WHEEL UPPER/LOWER SELECT BUTTON and INDICATORS

PINCH BEND DEPTH CONTROL KNOB
 Sets the amount of pitch change.

PITCH BEND WHEEL
 To change the pitch

CUT OFF FREQUENCY CONTROL KNOB

MODULATION WHEEL
 The modulation wheel has no effect when it rotated to "MINI" direction, add modulation when it rotated to "MAX" direction.

SPLIT MODE ON/OFF BUTTON

SPLIT MODE SELECT BUTTON and INDICATORS

COMPARE/EDIT RECALL/KEY TRANS SELECT BUTTONS and INDICATORS

NOISE and SAMPLE INPUT CONTROL BUTTONS

NUMERIC DISPLAY

VCO WAVEFORM SELECT BUTTON and INDICATORS

WRITE BUTTON

CASSETTE INTERFACE SELECT BUTTON

PROGRAM SELECT BUTTON
 To select the Bank and Preset Number.
 To Select Tape Interface.
 To Sets MIDI channels.
 To Sets and Select Split preset.

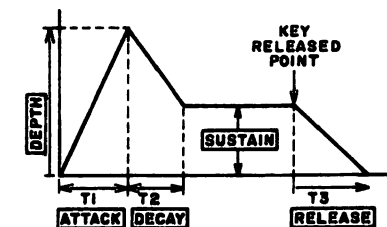

ATTCK: Sets the amount of time (T1).
 DECAY: Sets the amount of time (T2).
 SUSTAIN: Sets the level.
 RELEASE: Sets the amount of time (T3) after a key is released.
 DEPTH LEVEL: Sets the overall amplitude of the maximum deflection and also the sustain level.

Fig. 3-1

IV. THE KEYBOARD REACTION-SHIP TO EQUALLY TEMPERED SCALE FREQUENCIES AND MUSICAL-NOTATION.

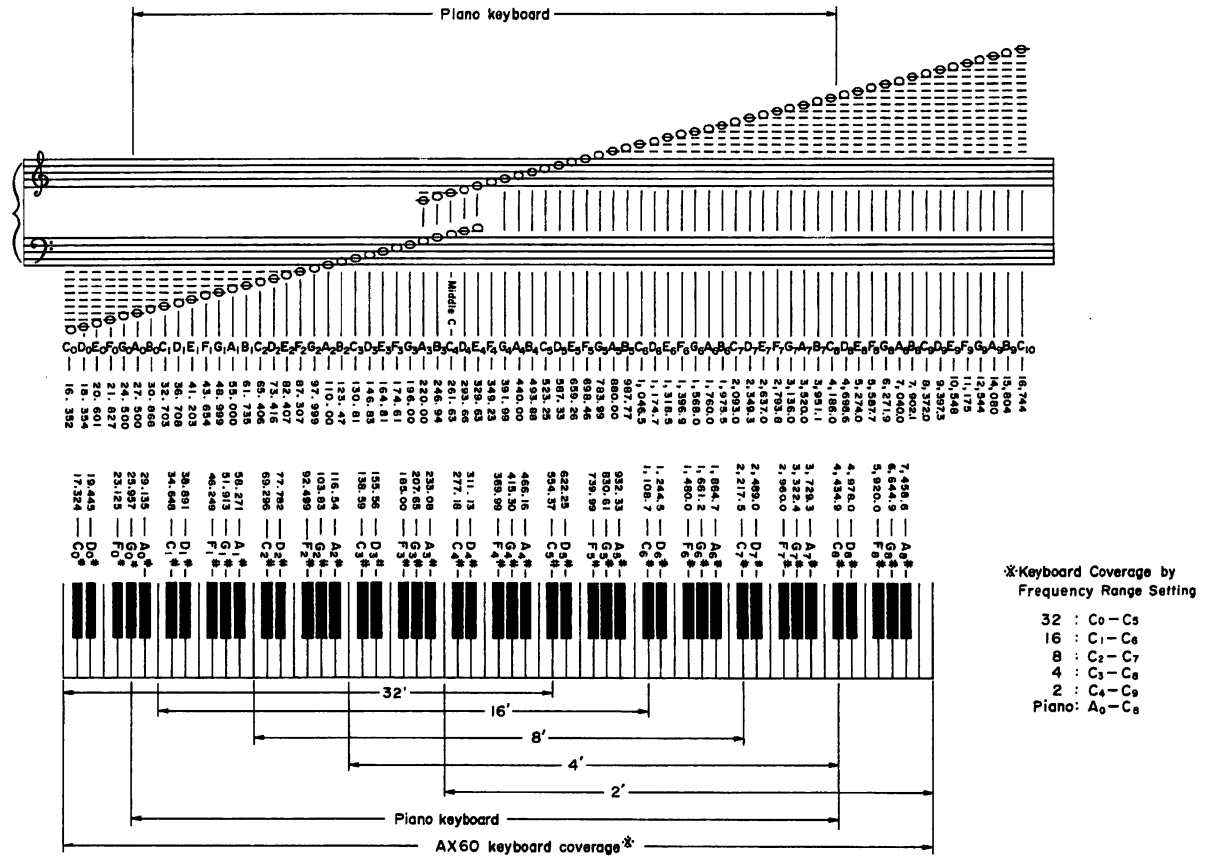

Fig. 4-1

V. PRINCIPAL PARTS LOCATION

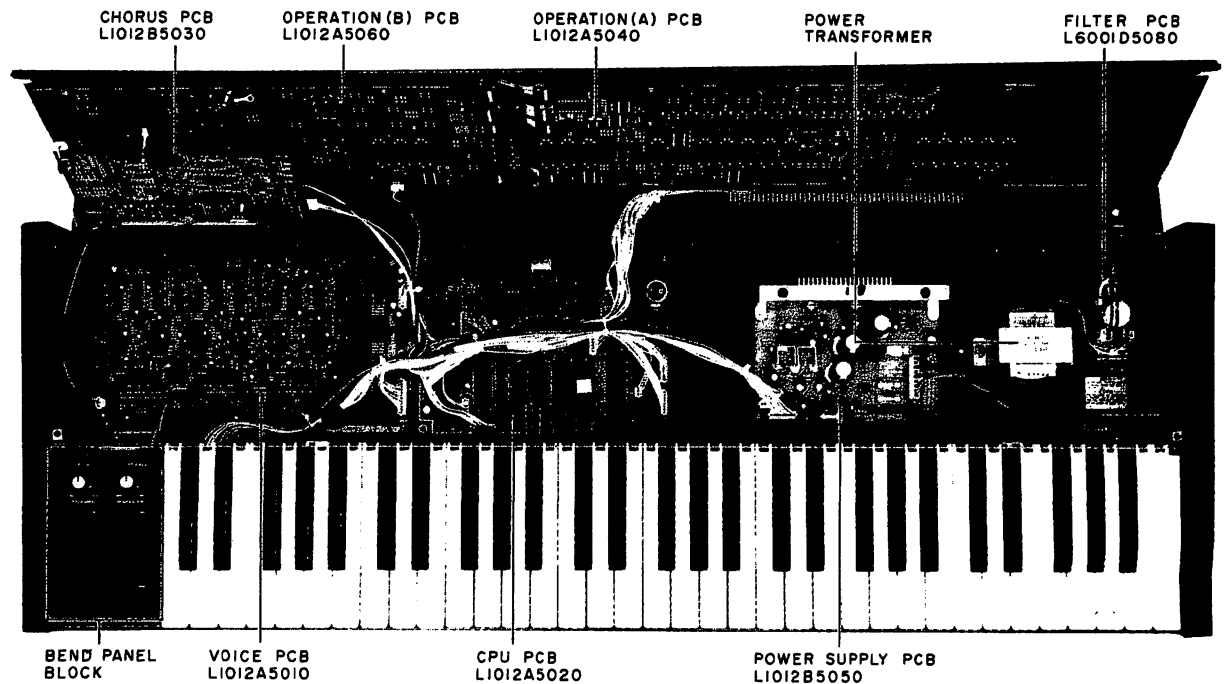

Fig. 5-1

VI. ADJUSTMENT

6-1. BALANCE OF $\pm 6V$ ON THE POWER SUPPLY PC BOARD

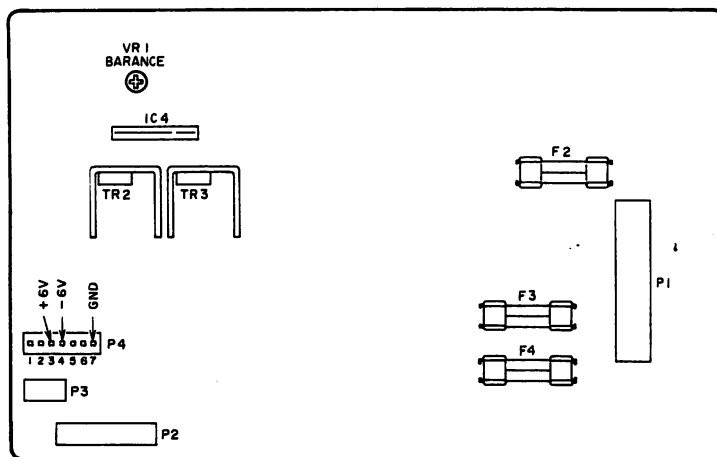

Fig. 6-1 POWER SUPPLY PCB Adjustment Points

- 1) Connect a Digital DC Voltmeter between Pin **3** (+6V) and Pin **7** (GND) of connector P4 on the POWER SUPPLY PCB as shown Fig. 6-1.
- 2) Read the + Voltage Value at the Pin **3**, and connect a Digital DC Voltmeter to Pin **4**.
- 3) Adjust VR1 so that the Voltage Value at Pin **4** and Pin **3** are equal or within $\pm 0.1V$.

6-2. OFF-SET OF FINAL VCA ON THE VOICE PC BOARD

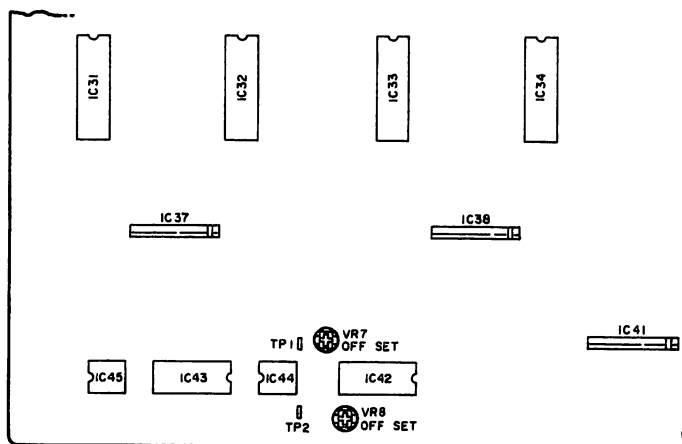

Fig. 6-2 VOICE PCB Adjustment Points

- 1) Set the ENVELOPE GENERATOR to VCA mode and set the EG DEPTH Control to maximum position.
- 2) Connect a Digital Voltmeter between TP1 and GND and adjust VR7 so that the Digital Voltmeter Read 0 ± 2 mV.
- 3) Connect a Digital Voltmeter between TP2 and GND and adjust VR8 as same manner as VR7.

6-3. BALANCE OF BBD OUTPUT ON THE CHORUS PC BOARD

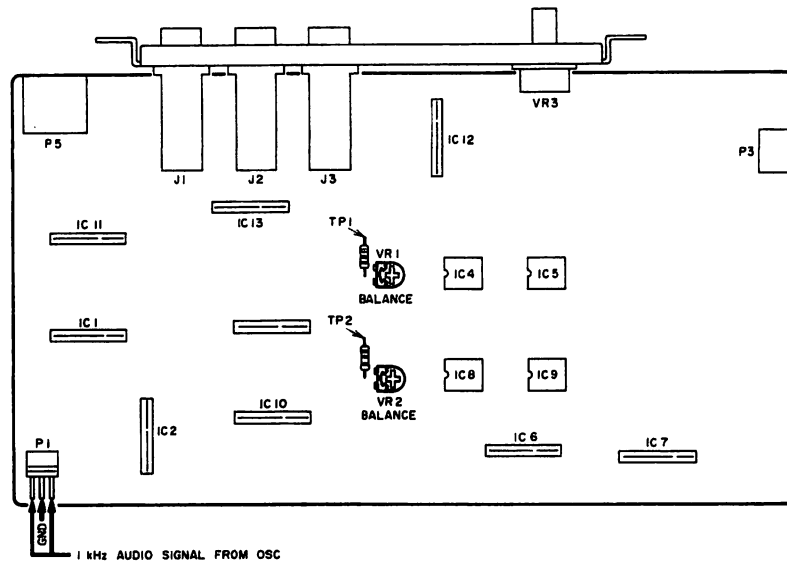

Fig. 6-3 CHORUS PCB Adjustment Points and Instrument Connection

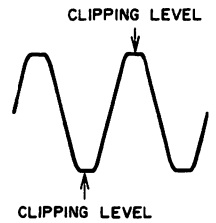

Fig. 6-4

- 1) Set CHORUS switch to "2".
- 2) Connect an oscilloscope between TP1 and GND on the CHORUS PC Board.
- 3) Connect an Audio Signal Generator to Pin 1 and 3 of connector P1 on the CHORUS PC Board, and supply 1 kHz Audio Sine wave signal, and Adjust output level control of Audio Generator, so that the waveform on

the oscilloscope is clipped a bit.

- 4) Adjust VR1 so that the Clipping level at upper side and lower side of the waveform are the same clipping level.
- 5) Connect an oscilloscope between TP2 and GND, and adjust VR2 as same manner as VR1.

6-4. OFF-SET OF IC6 (LF356) ON THE CPU PC BOARD

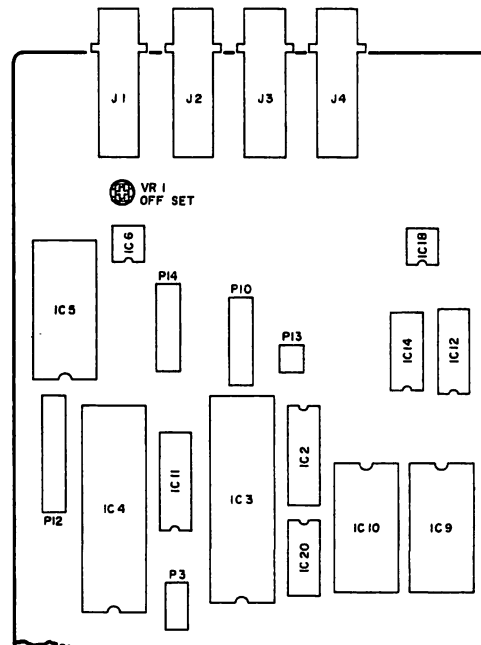

Fig. 6-5 CPU PCB ADJUST POINT

- 1) Set to center position of VR1 on the CPU PC Board.

VII. PC BOARD TITLES AND IDENTIFICATION NUMBERS

PC Board Title		PC Board Number	Remarks
VOICE	PC Board	L1012A5010	
CPU	PC Board	L1012A5020	
CHORUS	PC Board	L1012B5030	
OPERATION (A)	PC Board	L1012A5040	
POWER SUPPLY	PC Board	L1012A5050	
OPERATION (B)	PC Board	L1012A5060	
KEYBOARD	PC Board	—	
LINE FILTER	PC Board	L6001D5080	

VIII. MIDI IMPLEMENTATION CHART

MIDI Implementation Chart Version : 1.0

Function ...	Transmitted	Recognized	Remarks
Basic Default Channel Changed	1 - 16 1 - 16	1 - 16 * 1 - 16 *	* memorized
Mode Default Messages Altered	MODE 3, MODE 4 *****	MODE 3 x x	memorized
Note Number : True voice	36 - 96 *****	0 - 127 24 - 120	
Velocity Note ON Note OFF	x 9nH V=40h x 9nH V=0	x x	
After Key's Touch Ch's	x x	x x	
Pitch Bender	○	○	8bit RESO
Control Change	1 ○ 7 x 64 ○	○ ○ ○	Modulation wheel Volume Sustain foot sw
Prog Change : True #	○ (0 - 63) *****	○ 0 - 127 0 - 63	
System Exclusive	x	x	
System : Song Pos : Song Sel Common : Tune	x x x	x x ○	
System :Clock Real Time :Commands	x x	x x	
Aux :Local ON/OFF :All Notes OFF Mes- :Active Sense sages:Reset	x ○ * x x	x ○ x x	* Set mode only
Notes			

Mode 1 : OMNI ON, POLY Mode 2 : OMNI ON, MONO
Mode 3 : OMNI OFF, POLY Mode 4 : OMNI OFF, MONO

○ : Yes
x : no

SECTION 2

PARTS LIST

TABLE OF CONTENTS

RECOMMENDED SPARE PARTS LIST	13
1. PC BOARD BLOCK	14
2. VOICE PC BOARD.....	14
3. CPU PC BOARD	14
4. CHORUS PC BOARD	14
5. OPERATION (A) PC BOARD.....	14
6. OPERATION (B) PC BOARD	14
7. POWER SUPPLY PC BOARD	15
8. FILTER PC BOARD.....	15
9. PANEL BEND BLOCK	15
10. ASSEMBLY BLOCK	17
11. FINAL ASSEMBLY BLOCK	17
INDEX.....	18

This Manual is FOR INTERNAL USE ONLY and must not be made available to unauthorized personal. No part of this manual may be reproduced in any form without permission from AKAI-ELECTRIC CO., LTD., Tokyo, Japan.

ATTENTION

1. When placing an order for parts, be sure to list Part No., Model No. and the description of each part. Otherwise, the non-delivery of the part or the delivery of a wrong part may result.
2. Please make sure that Part No. is correct when ordering. If not, a part different from the one you ordered may be delivered.
3. Since the parts shown in Parts List of Preliminary Service Manual may have been the subject of changes, please use this Parts List for all future reference.

HOW TO USE THIS PARTS LIST

1. This Parts List lists those parts which are considered necessary for repairs. Other common parts, such as resistors and capacitors, are listed in the "Common List for Service Parts" from which these parts should be selected and stocked.
2. The Recommended Spare Parts List shows those parts in the Parts List which are considered particularly important for service.
3. Parts not shown in the Parts List and "Common List for Service Parts" will not in principle be supplied.
4. How to read the Parts List.

a) Mechanism Block

b) PC Board

2. HEAD BASE BLOCK

6. MAIN PC BOARD

REF. NO.	PART NO.	DESCRIPTION
2-1x	BH-T2023A320A	HEAD BASE BLOCK
2-2	HP-H2206A010A	HEAD R/P PR4-8FU C
2-3	ZS-477876	PAN20x03STL CMT
2-4	ZS-536488	BID20x08STL CMT
2-5	ZG-402895	SP CS ANGLE ADJUST

REF. NO.	PART NO.	DESCRIPTION
6-IC1	EI-324536	IC HD14049BP
6-IC2	EI-336801	IC MB8841-564M
6-C1A	EC-338399	C MMY V 223M 250AC [U,E,B,S]
6-C1B	EC-350949	C MMY V 223M 250DC [J]
6-C1C	EC-338397	C MMY V 223M 125AC [C,A]
6-X1	EI-318384	OSC X'TAL NC-18C

SP (Service Parts) Classification

A small "x" indicates that this part is not shown in the Photo or Illustration.

This number corresponds with the individual parts index number in that figure.

This number corresponds with the Figure Number.

Symbols for primary destination

[A]: AAL(U.S.A.) [S]: SAA(Australia)
 [B]: BEAB(England) [U]: U/T(Universal Area)
 [C]: CSA(Canada) [V]: VDE(W. Germany)
 [E]: CEE(Europe) [Y]: Custom Version
 [J]: JPN(Japan)

SP (Service Parts) Classification

These reference symbols correspond with component symbols in the Schematic Diagrams.

The available PC Board Blocks are listed separately.

5. When Part No. is known, Parts Index at end of Parts List can be used to locate where that part is shown in Parts List by its Reference No. listed at right of Part No.

WARNING

Δ INDICATES SAFETY CRITICAL COMPONENTS. FOR CONTINUED SAFETY, REPLACE SAFETY CRITICAL COMPONENTS ONLY WITH MANUFACTURE'S RECOMMENDED PARTS

AVERTISSEMENT

Δ IL INDIQUE LES COMPOSANTS CRITIQUES DE SÉCURITÉ. POUR MAINTENIR LE DEGRÉ DE SÉCURITÉ DE L'APPAREIL, NE REMPLACER QUÉ DES PIÈCES RECOMMANDÉES PAR LE FABRICANT

RECOMMENDED SPARE PARTS LIST

Because, if the parts listed below are on hand, almost any repair can be accomplished, we suggest that you stock these Recommended Spare Parts Items.

REF. NO.	PART NO.	DESCRIPTION	REF. NO.	PART NO.	DESCRIPTION
1	N BK-364242	KEYBOARD SWITCH ESK-7022 61KEY	71	N ES-364478	Δ SW SEESAW SDDT SPST TYPE=A T=8.5
2	N BT-364697	Δ TRANS POWER L1012-10 (J)	72	N ES-364255	SW SLIDE SSP322
3	N BT-364243	Δ TRANS POWER L1012-30 (C, A)	73	ES-349367	SW TACT SKHHAK003A
4	N BT-364698	Δ TRANS POWER L1012-50 (E, V, B, S)	74	ET-356817	Δ TR 2SB891 Q, R
5	ED-200213	Δ D SILICON DBA40C-K15 200/2.6A	75	N ET-364560	PHOTO SENSOR NJL5127D
6	ED-357038	Δ D SILICON DBB10B 100/1.0A	76	ET-348302	TR FET 2SK381 C, D F05
7	ED-359863	D LED LN81CV-(LF) AK ORANGE	77	ET-353899	TR 2SA1317 S, T, U
8	N ED-364261	D LED SLP-981C-50	78	ET-360067	TR 2SC3330 T, U F05
9	ED-357754	D SILICON DS135D 200/1.0A	79	ET-349081	TR 2SC3383 S, T
10	ED-301911	D SILICON H DS448	80	ET-349608	TR 2SC3383 T, U
11	ED-344280	D SILICON H GMA-01-FY2 F05	81	ET-349592	TR 2SC3400 F05
12	ED-331626	D ZENER H HZ3 B2	82	ET-352994	TR 2SC3401 F05
13	ED-329058	D ZENER H HZ5 C1	83	ET-354083	TR 2SD1189 Q, R
14	ED-319167	D ZENER H HZ6 C3	84	EV-358829	R S-FIX H RH0651CJ4J 3P 223
15	ED-306012	D ZENER H HZ7 A3	85	EV-307709	R S-FIX H RH0651CJ4 3P 0.05W 223
16	ED-346463	D ZENER H HZ7FA F10 C3	86	EV-336770	R S-FIX H RH0651CS4 3P 0.05W 473
17	EF-355226	Δ FUSE BET T 1.00A 250V (B)	87	N EV-364326	R S-FIX H VM5CK-PV3P 0.2W 222
18	EF-359343	Δ FUSE BET T 1.60A 250V (B)	88	N EV-364321	VR ROTARY 12P10×OD B103
19	EF-358974	Δ FUSE BET T 630MA 250V (B)	89	EV-354254	VR ROTARY 16L10×OW 103 CUSTOM-2
20	EF-623103	Δ FUSE SEMKO T 1.00A 250V (E, V, S)	90	EV-358043	VR ROTARY 16L10×OX B103 L=20
21	EF-601964	Δ FUSE SEMKO T 1.60A 250V (E, V, S)	91	EV-354253	VR ROTARY 16P20×3T A503
22	EF-601942	Δ FUSE SEMKO T 630MA 250V (E, V, S)	92	N EV-364277	VR SLIDE 30P1SVOJ 3BM203
23	EF-309388	Δ FUSE TSC A 250V 0.80A (J)	93	N EV-364276	VR SLIDE 45PSVOI 3B203
24	EF-309387	Δ FUSE TSC A 250V 1.00A (J)	94	N EV-364267	VR SLIDE 45P1SVOK B103
25	EF-311839	Δ FUSE TSC A 250V 1.60A (J)	95	EZ-358816	BATTERY LITHIUM BR2032-1HF
26	EF-309392	Δ FUSE TSC 125V 1.25A (C, A)			
27	EF-308847	Δ FUSE TSC 125V 1.60A (C, A)			
28	EF-348123	Δ IC M5230L			
29	EI-359552	Δ IC M5236L			
30	EI-359626	Δ IC NJM78M 15A			
31	EI-359628	Δ IC NJM79M 15A			
32	EI-355113	IC BA715 STD			
33	N EI-364319	IC CD4051BE			
34	N EI-364246	IC CEM3394			
35	EI-360954	IC IR9311			
36	N EI-364378	IC LA6082D			
37	N EI-364245	IC LA6082S			
38	N EI-362710	IC LC3517NL-20			
39	N EI-364273	IC LF356N			
40	N EI-364250	IC MD6205			
41	N EI-364308	IC MN3009			
42	EI-360228	IC MN3101			
43	EI-353227	IC M5216L			
44	EI-337228	IC M5218L			
45	N EI-355904	IC M74LS04P			
46	N EI-364275	IC M74LS05N			
47	N EI-355906	IC M74LS14P			
48	N EI-355917	IC M74LS373P			
49	EI-355909	IC M74LS38P			
50	EI-355910	IC M74LS42P			
51	N EI-364247	IC NJM13600			
52	N EI-364253	IC PST520D-2			
53	EI-302233	IC TC4051BP			
54	EI-310036	IC TC4066BP			
55	EI-360025	IC TC74HC138P			
56	EI-356049	IC TC74HC139P			
57	EI-360036	IC TC74HC32P			
58	N EI-364674	IC TMM2764ADC AX60 V1.2 CUSTOM			
59	EI-357060	IC UPD7811G-144			
60	EI-354146	IC UPD8253C-2			
61	EI-354149	IC UPD8255AC-2			
62	EI-354232	IC UPD8279C-2			
63	N EI-364257	OSC X'TAL NR-18 12MC			
64	N EJ-364256	DIN J M1704 3P			
65	EJ-360771	DIN J TCS5037-01-241 13P			
66	N EM-364260	IND LE GL-7P201			
67	EQ-348929	RELAY SIG G5A-232P 2TR 12V			
68	ER-326169	Δ R FUSE ERD2FC S10 1/4W 22ROG			
69	ER-328278	Δ R FUSE ERD2FC 1/4W 10ROG			
70	ES-306430	Δ SW SLIDE J-S4013#01 01-2			

“NOTE” N: New Parts

1. PC BOARD BLOCK

REF. NO.	PART NO.	DESCRIPTION
1-1	BA-L1012A030A	PC VOICE BLK AX60
1-2	BA-L1012A040A	PC CPU BLK AX60
1-3	BA-L1012A080A	PC CHORUS BLK AX60
1-4	BA-L1012A060A	PC OPERATION (A) BLK AX60
1-5	BA-L1012A070A	PC OPERATION (B) BLK AX60
1-6	BA-L1012A050A	PC POWER BLK AX60

2. VOICE PC BOARD

REF. NO.	PART NO.	DESCRIPTION
2-IC1, 2	EI-364319	IC CD4051BE
2-IC3, 4	EI-302233	IC TC4051BP
2-IC5 to 20	EI-364245	IC LA6082S
2-IC21 to 27, 41	EI-355113	IC BA715 STD
2-IC28 to 30	EI-310036	IC TC4066BP
2-IC31 to 36	EI-364246	IC CEM3394
2-IC37 to 39	EI-355113	IC BA715 STD
2-IC40	EI-360954	IC IR9311
2-IC42, 43	EI-364247	IC NJM13600
2-IC44, 45	EI-364378	IC LA6082D
2-TR1 to 3	ET-349592	TR 2SC3400 F05
2-TR4	EI-360067	TR 2SC3330 T, U F05
2-TR5, 14, 15	ET-349081	TR 2SC3383 S, T
2-D1	ED-331626	D ZENER H HZ3 B2
2-D2	ED-346463	D ZENER H HZ27FA F10 C3
2-D3	ED-301911	D SILICON H DS448
2-D4 to 19	ED-344280	D SILICON H GMA-01 FY2 F05
2-VR7, 8	EV-336770	R S-FIX H RH0651CS4 3P 0.05W 473
2-R112 to 117	ER-309827	R MF V 1/4W 2703F
2-C80 to 85	EC-362220	C PP V F05 PP 202J 50DC
2-J1	EI-360771	DIN J TCS5037-01-241 13P
2-1	EI-363001	SOCKET IC DILB20P-RJ

3. CPU PC BOARD

REF. NO.	PART NO.	DESCRIPTION
CPU PC BOARD		
3-IC1	EI-357060	IC UPD7811G-144
3-IC2	EI-355917	IC M74LS373P
3-IC3	EI-354232	IC UPD8279C-2
3-IC4	EI-354149	IC UPD8255AC-2
3-IC5	EI-364250	IC MD6205
3-IC6	EI-364273	IC LFS356N
3-IC8, 9	EI-362710	IC LC3517NL-20
3-IC10	EI-354146	IC UPD8253C-2
3-IC11	EI-355917	IC M74LS373P
3-IC12, 15	EI-356049	IC TC74HC139P
3-IC13	EI-355906	IC M74LS14P
3-IC14	EI-360036	IC TC74HC32P
3-IC16	EI-364253	IC PST520D-2
3-IC17	EI-360025	IC TC74HC138P
3-IC18	EI-360954	IC IR9311
3-IC19	EI-364275	IC M74LS05N
3-IC20	EI-355904	IC M74LS04P
3-TR1	ET-349592	TR 2SC3400 F05
3-TR2, 3	ET-349608	TR 2SC3383 T, U
3-TR4	ET-360067	TR 2SC3330 T, U F05
3-D1 to 9	ED-301911	D SILICON H DS448
3-SW1	ES-364255	SW SLIDE SSP322
3-VR1	EV-307709	R S-FIX H PH0651CJ4 3P 0.05W 223
3-PH1	ET-364560	PHOTO SENSOR NJL5127D
3-X1	EI-364257	OSC X'TAL NR-18 12MC
3-CR1, 2	EH-355561	COMP R EXB-R88 103K
3-R30	ER-307764	R MF H F10 1/4W 2211F
3-R31	ER-326169	R FUSE ERD2FC S10 1/4W 22ROG
3-R56	ER-355564	R OMF H S15 FS 1W 911J
3-J1 to 4	EJ-364322	PHONE J 2P HLJ0520-110 W/NUT WASHER
3-J5	EJ-364256	DIN J M1704 3P

REF. NO.	PART NO.	DESCRIPTION
3-1	EJ-358691	SOCKET IC DILB28P-8J
ASSEMBLY BLOCK		
3-IC7	EI-364674	IC TMM2764ADC AX60 V1.2 CUSTOM
3-BT1	EZ-358816	BATTERY LITHIUM BR2032-1HF

4. CHORUS PC BOARD

REF. NO.	PART NO.	DESCRIPTION
4-IC1 to 3, 6, 7, 10, 11, 13	EI-337228	IC M5218L
4-IC4, 8	EI-364308	IC MN3009
4-IC5, 9	EI-360228	IC MN3101
4-IC12	EI-353227	IC M5216L
4-TR1, 2, 5, 8, 18	ET-348302	TR FET 2SK381 C, D F05
4-TR3, 4, 12, 13, 16, 17	ET-360067	TR 2SC3330 T, U F05
4-TR6, 7, 11, 15	ET-353899	TR-2SA1317 S, T, U
4-TR9, 10, 14	ET-352994	TR 2SC3401 F05
4-D1 to 10	ED-301911	D SILICON H DS448
4-VR1, 2	EV-358829	R S-FIX H RH0615CJ4J 3P 223
4-VR3	EV-364321	VR ROTARY 12P10x0D B103
4-RL1	EQ-348929	RELAY SIG G5A-232P 2TR 12V
4-R120 to 123	ER-364336	R OMF H S12 FS 1W 201J
4-C9	EC-355170	C PP V S05 CQMFS92 181J 50DC
4-C24	EC-360719	C PP V S05 CQMFS92 101J 50DC
4-C35, 37	EC-364306	C PP V S05 CQMFS92 221J 50DC
4-J3	EJ-353031	PHONE J 3P HLJ0520-010

5. OPERATION (A) PC BOARD

REF. NO.	PART NO.	DESCRIPTION
5-IC1, 2	EI-302233	IC TC4051BP
5-IC3, 4	EI-355909	IC M74LS38P
5-IC5	EI-355910	IC M74LS42P
5-TR1, 2, 3	ET-353899	TR 2SA1317 S, T, U
5-D1 to 4, 7	ED-364261	D LED SLP-981C-50
5-D5, 6	ED-359863	D LED LN81CV-(LF) AK ORANGE
5-SW1 to 22	ES-349367	SW TACT SKHHAK003A
5-VR1 to 14	EV-364267	VR SLIDE 45P1SVOK B103
5-LN1	EM-364260	IND LE GL-7P201

6. OPERATION (B) PC BOARD

REF. NO.	PART NO.	DESCRIPTION
6-IC1	EI-302233	IC TC4051BP
6-TR1 to 5	ET-353899	TR 2SA1317 S, T, U
6-D1 to 38	ED-364261	D LED SLP-981C-50
6-SW1 to 21	ES-349367	SW TACT SKHHAK003A
6-VR1 to 4	EV-364267	VR SLIDE 45P1SVOK B103
6-VR6	EV-364277	VR SLIDE 30P1SVOJ 3BM203 C
6-VR7	EV-364276	VR SLIDE 45PSVOI 3B203

7. POWER SUPPLY PC BOARD

REF. NO.	PART NO.	DESCRIPTION
POWER SUPPLY PC BOARD		
7-IC1	EI-359552	Δ IC M5236L
7-IC2	EI-359626	Δ IC NJM78M15A
7-IC3	EI-359628	Δ IC NJM79M15A
7-IC4	EI-348123	Δ IC M5230L
7-TR1, 3	ET-356817	Δ TR 2SB891 Q, R
7-TR2	ET-354083	Δ TR 2SD1189 Q, R
7-TR4 to 6	ET-360067	TR 2SC3330 T, U F05
7-D1	ED-200213	Δ D SILICON DBA40C-K15 200/2.6A
7-D2	ED-357038	Δ D SILICON DBB10B 100/1.0A
7-D3, 5, 6, 12	ED-357754	D SILICON DS135D 200/1.0A
7-D4	ED-319167	D ZENER H HZ6 C3
7-D7	ED-306012	D ZENER H HZ7 A3
7-D9, 11	ED-329058	D ZENER H HZ5 C1
7-D13	ED-301911	D SILICON H DS448
7-VR1	EV-364326	R S-FIX H VM5CK-PV3P 0.2W 222
7-FR1, 2	ER-328278	Δ R FUSE ERD2FC 1/4W 10ROG
7-R1	ER-360725	Δ R OMF H S12 FS 1W 221J
7-R2	ER-360732	R MF H F10 1/4W 4301G
7-R3	ER-356113	R MF H F10 1/4W 1302G
7-R4	ER-356259	R MF H F10 1/4W 3301G
7-R5	ER-341577	R MF H F10 1/4W 7501F
7-R6	ER-305128	R MF H F10 1/4W 1502F
7-R7	ER-364324	R MF H F10 1/4W 1402G
7-C1	EC-322804	C EC V CUT SM 472M 16.0DC
7-C2, 3	EC-316231	C EC V CUT SM 222M 35.0DC
7-1	EZ-200473	SILICON RUBBER SHEET TC-30
7-2	ZW-632226	WASHER INSULATOR (BUSH M)
ASSEMBLY BLOCK		
7-F2	EF-311839	Δ FUSE TSC A 250V 1.60A (J)
7-F2A	EF-308847	Δ FUSE TSC 125V 1.60A (C, A)
7-F2B	EF-601964	Δ FUSE SEMKO T 1.60A 250V (E, V, S)
7-F2C	EF-359343	Δ FUSE BET T 1.60A 250V (B)
7-F3, 4	EF-309387	Δ FUSE TSC A 250V 1.00A (J)
7-F3A, 4A	EF-309392	Δ FUSE TSC 125V 1.25A (C, A)
7-F3B, 4B	EF-623103	Δ FUSE SEMKO T 1.00A 250V (E, V, S)
7-F3C, 4C	EF-355226	Δ FUSE BET T 1.00A 250V (B)

8. FILTER PC BOARD

REF. NO.	PART NO.	DESCRIPTION
FILTER PC BOARD		
8-FL1	EO-360068	COIL LF LF-2 B
8-C2, 3	EC-358450	Δ C CE V B 102M 400AC
8-C4	EC-338411	Δ C CE V FZ 103P 400AC
ASSEMBLY BLOCK		
8-F1	EF-309388	Δ FUSE TSC A 250V 0.80A (J)
8-F1A	EF-309392	Δ FUSE TSC 125V 1.25A (C, A)
8-F1B	EF-601942	Δ FUSE SEMKO T 630MA 250V (E, V, S)
8-F1C	EF-358974	Δ FUSE BET T 630MA 250V (B)

9. PANEL BEND BLOCK

REF. NO.	PART NO.	DESCRIPTION
9-1	SK-B352952x4	KNOB MONITOR WHITE PART
9-2	SP-354550	PANEL BEND
9-3	MI-354552	WHEEL
9-4	ZG-354553	SP BEND
9-5	ZS-310984	PT BR30x08STL CMT
9-VR904	EV-354253	VR ROTARY 16P20x3T A503
9-VR905, 906	EV-358043	VR ROTARY 16L10xOX B103 L=20
9-VR907	EV-354254	VR ROTARY 16L10xOW 103

CUSTOM-2

PANEL BEND BLOCK

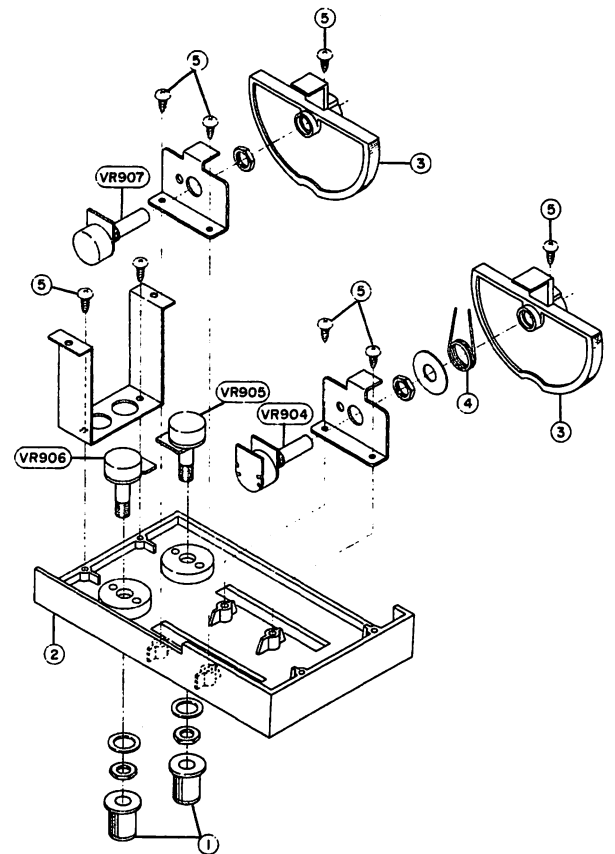

ASSEMBLY BLOCK

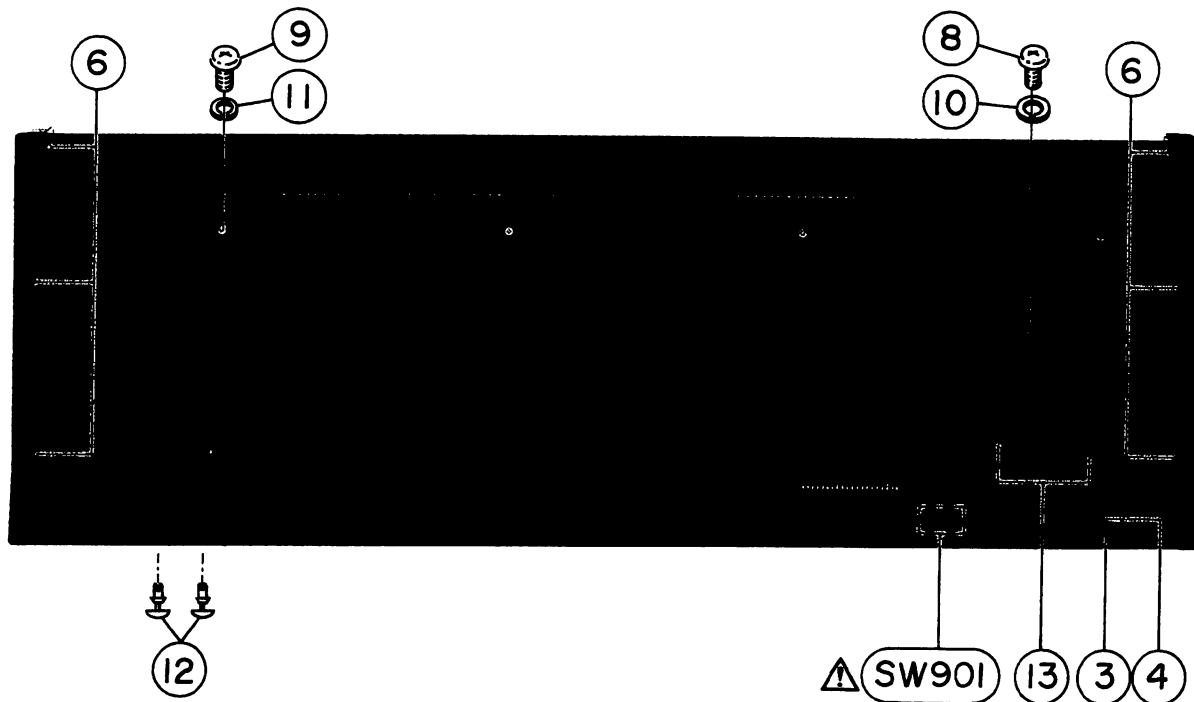
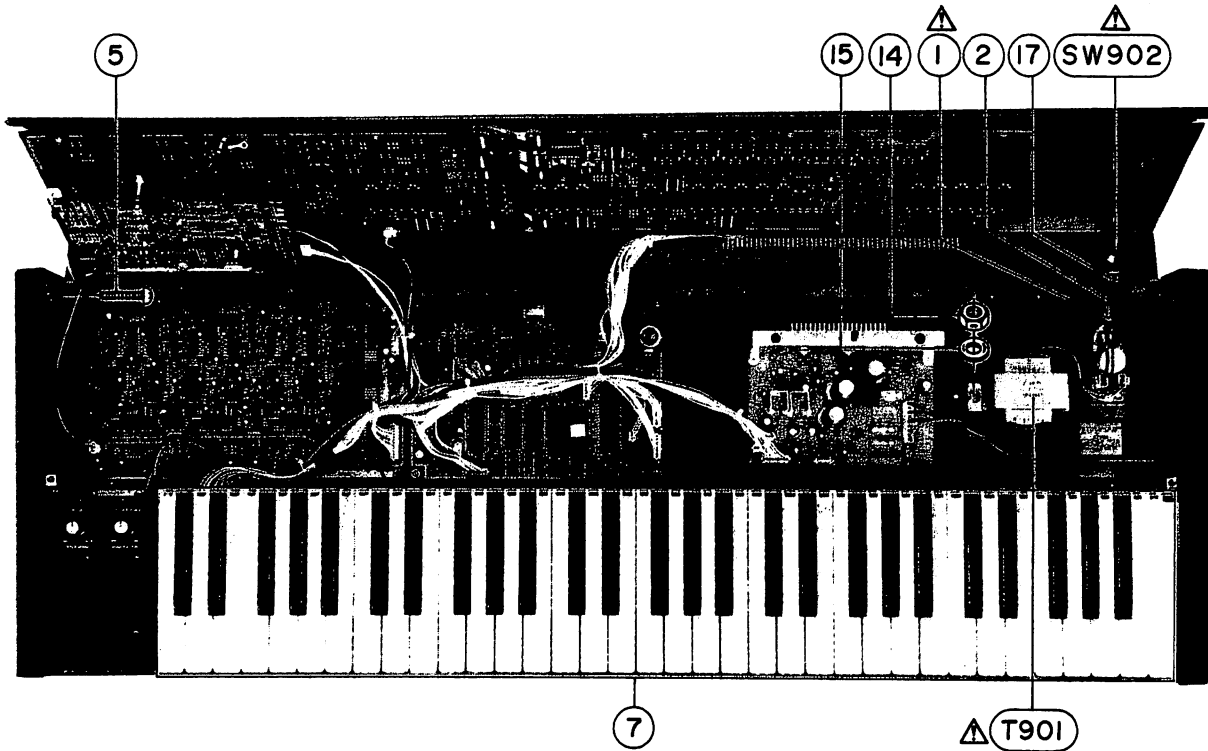

PARTS LIST

FINAL ASSEMBLY BLOCK

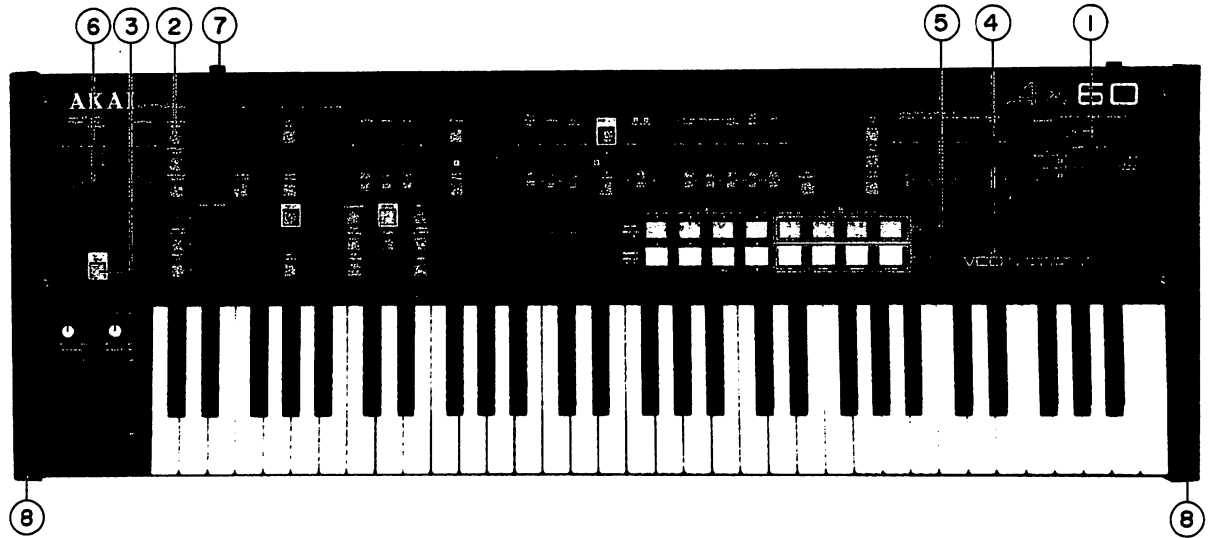

10. ASSEMBLY BLOCK

REF. NO.	PART NO.	DESCRIPTION
10-1	EW-524845	Δ AC CORD 2 CORES VM1165B, VFF J (J)
10-1A	EW-358858	Δ AC CORD 2 CORES KP-11 SJTAWG18 UC (C, A)
10-1B	EW-359641	Δ AC CORD 2 CORES KP-419C/KS-17 (E, V)
10-1C	EW-358631	Δ AC CORD 2 CORES KS-17 LTBS2F BS (B)
10-1D	EW-358630	Δ AC CORD 2 CORES KP560 LTSA2F KS17 S (S)
10-2	EZ-631945	STRAIN RELIEF SR-4N-4 (J)
10-2A	EZ-302906	STRAIN RELIEF SR-6N-4 (C, A)
10-3	SA-332850	ROUND FOOT
10-4	ZS-344754	ST PAN30×06STL CMT CO80 (FOOT FIX)
10-5	ZS-362286	PT BID40×18STL BCM
10-6	ZS-341960	ST BID40×06STL BNI
10-7	BK-364242	KEYBOARD SWITCH ESK-7002 61KEY
10-8	ZS-354230	BID50×08STL BNI
10-9	ZS-201778	PAN40×08STL BNI
10-10	ZW-274026	SW50
10-11	ZW-273914	SW40
10-12	ZW-698308	RV NYL30×055 BL
10-13	ZS-411232	BID40×10STL BNI (TRANS POWER FIX)
10-14	ZW-413267	N FRANGE 40STL CMT (TRANS POWER FIX)
10-15	ZW-273892	TW40 (TRANS POWER FIX)
10-16x	ZS-350934	PT BR30×08STL BNI (E, V, B, S) (SW 901 FIX)
10-17	ZS-355511	BID30×06STL BNI
10-T901	BT-364697	Δ TRANS POWER L1012-10 (J)
10-T901A	BT-364243	Δ TRANS POWER L1012-30 (C, A)
10-T901B	BT-364698	Δ TRANS POWER L1012-50 (E, V, B, S)
10-SW901	ES-306430	Δ SW SLIDE J-S4013 #01 01-2 (E, V, B, S)
10-SW902	ES-364478	Δ SW SEESAW SDDT SPST TYPE =A T=8.5
10-J901x	EJ-358633	Δ SOCKET INLET SOT017 2P (E, V, B, S)

11. FINAL ASSEMBLY BLOCK

REF. NO.	PART NO.	DESCRIPTION
11-1	BD-B364215B	PANEL FRONT AX60 (J) PART
11-1A	BD-B364215	PANEL FRONT AX60 (A, C) PART
11-1B	BD-B364215C	PANEL FRONT AX60 (E, V, B, S) PART
11-2	SK-364216A	KNOB PUSH (A) GRAY
11-3	SK-364216B	KNOB PUSH (B) RED
11-4	SK-364218	KNOB PUSH (C) WHITE
11-5	SK-364218B	KNOB PUSH (D) VIOLET
11-6	SK-364219	KNOB SLIDE
11-7	SK-322105	KNOB
11-8	SC-364225	COVER SIDE

INDEX

AX60

PART NO.	REF. NO.	PART NO.	REF. NO.	PART NO.	REF. NO.	PART NO.	REF. NO.
BA-L1012A030A	1-1	ED-364261	5-D7	EI-354232	3-IC3	EO-360068	8-FL1
BA-L1012A040A	1-2	ED-364261	5-D3	EI-355113	2-IC41	EQ-348929	4-RL1
BA-L1012A050A	1-6	ED-364261	5-D1	EI-355113	2-IC22	ER-305128	7-R6
BA-L1012A060A	1-4	ED-364261	5-D2	EI-355113	2-IC23	ER-307764	3-R30
BA-L1012A070A	1-5	ED-364261	5-D4	EI-355113	2-IC24	ER-309827	2-R114
BA-L1012A080A	1-3	ED-364261	6-D5	EI-355113	2-IC25	ER-309827	2-R112
BD-B364215	11-1A	ED-364261	6-D6	EI-355113	2-IC26	ER-309827	2-R113
BD-B364215B	11-1	ED-364261	6-D7	EI-355113	2-IC27	ER-309827	2-R115
BD-B364215C	11-1B	ED-364261	6-D9	EI-355113	2-IC37	ER-309827	2-R117
BK-364242	10-7	ED-364261	6-D10	EI-355113	2-IC38	ER-309827	2-R116
BT-364243	10-T901A	ED-364261	6-D11	EI-355113	2-IC39	ER-326169	3-R31
BT-364697	10-T901	ED-364261	6-D13	EI-355113	2-IC21	ER-328278	7-FR1
BT-364698	10-T901B	ED-364261	6-D14	EI-355904	3-IC20	ER-328278	7-FR2
EC-316231	7-C3	ED-364261	6-D15	EI-355906	3-IC13	ER-341577	7-R5
EC-316231	7-C2	ED-364261	6-D17	EI-355909	5-IC3	ER-355564	3-R56
EC-322804	7-C1	ED-364261	6-D18	EI-355909	5-IC4	ER-356113	7-R3
EC-338411	8-C4	ED-364261	6-D19	EI-355910	5-IC5	ER-356259	7-R4
EC-355170	4-C9	ED-364261	6-D21	EI-355917	3-IC2	ER-360725	7-R1
EC-358450	8-C2	ED-364261	6-D22	EI-355917	3-IC11	ER-360732	7-R2
EC-358450	8-C3	ED-364261	6-D23	EI-356049	3-IC12	ER-364324	7-R7
EC-360719	4-C24	ED-364261	6-D25	EI-356049	3-IC15	ER-364336	4-R123
EC-362220	2-C81	ED-364261	6-D26	EI-357060	3-IC1	ER-364336	4-R120
EC-362220	2-C80	ED-364261	6-D27	EI-359552	7-IC1	ER-364336	4-R122
EC-362220	2-C83	ED-364261	6-D29	EI-359626	7-IC2	ER-364336	4-R121
EC-362220	2-C84	ED-364261	6-D30	EI-359628	7-IC3	ES-306430	10-SW901
EC-362220	2-C85	ED-364261	6-D31	EI-360025	3-IC17	ES-349367	5-SW6
EC-362220	2-C82	ED-364261	6-D33	EI-360036	3-IC14	ES-349367	5-SW22
EC-364306	4-C35	ED-364261	6-D34	EI-360228	4-IC5	ES-349367	5-SW4
EC-364306	4-C37	ED-364261	6-D35	EI-360228	4-IC9	ES-349367	5-SW3
ED-200213	7-D1	ED-364261	6-D38	EI-360954	2-IC40	ES-349367	5-SW17
ED-301911	2-D3	ED-364261	6-D20	EI-360954	3-IC18	ES-349367	5-SW21
ED-301911	3-D1	ED-364261	6-D24	EI-362710	3-IC8	ES-349367	5-SW14
ED-301911	3-D2	ED-364261	6-D12	EI-362710	3-IC9	ES-349367	5-SW6
ED-301911	3-D3	ED-364261	6-D8	EI-364245	2-IC12	ES-349367	5-SW19
ED-301911	3-D4	ED-364261	6-D36	EI-364245	2-IC11	ES-349367	5-SW2
ED-301911	3-D5	ED-364261	6-D28	EI-364245	2-IC13	ES-349367	5-SW7
ED-301911	3-D6	ED-364261	6-D32	EI-364245	2-IC14	ES-349367	5-SW10
ED-301911	3-D7	ED-364261	6-D4	EI-364245	2-IC9	ES-349367	5-SW1
ED-301911	3-D8	ED-364261	6-D16	EI-364245	2-IC15	ES-349367	5-SW15
ED-301911	3-D9	ED-364261	6-D1	EI-364245	2-IC8	ES-349367	5-SW13
ED-301911	4-D1	ED-364261	6-D2	EI-364245	2-IC19	ES-349367	5-SW5
ED-301911	4-D2	ED-364261	6-D3	EI-364245	2-IC17	ES-349367	5-SW8
ED-301911	4-D3	EF-308847	7-F2A	EI-364245	2-IC10	ES-349367	5-SW9
ED-301911	4-D4	EF-309387	7-F3	EI-364245	2-IC6	ES-349367	5-SW18
ED-301911	4-D5	EF-309387	7-F4	EI-364245	2-IC20	ES-349367	5-SW16
ED-301911	4-D7	EF-309388	8-F1	EI-364245	2-IC16	ES-349367	5-SW11
ED-301911	4-D8	EF-309392	7-F3A	EI-364245	2-IC18	ES-349367	5-SW20
ED-301911	4-D9	EF-309392	7-F4A	EI-364245	2-IC5	ES-349367	5-SW12
ED-301911	4-D6	EF-309392	8-F1A	EI-364245	2-IC7	ES-349367	6-SW17
ED-301911	4-D10	EF-311839	7-F2	EI-364246	2-IC31	ES-349367	6-SW19
ED-301911	7-D13	EF-355226	7-F3C	EI-364246	2-IC33	ES-349367	6-SW4
ED-306012	7-D7	EF-355226	7-F4C	EI-364246	2-IC34	ES-349367	6-SW16
ED-319167	7-D4	EF-358974	8-F1C	EI-364246	2-IC35	ES-349367	6-SW6
ED-329058	7-D9	EF-359343	7-F2C	EI-364246	2-IC36	ES-349367	6-SW8
ED-329058	7-D11	EF-601942	8-F1B	EI-364246	2-IC32	ES-349367	6-SW11
ED-331626	2-D1	EF-601964	7-F2B	EI-364247	2-IC42	ES-349367	6-SW1
ED-344280	2-D4	EF-623103	7-F4B	EI-364247	2-IC43	ES-349367	6-SW20
ED-344280	2-D5	EF-623103	7-F3B	EI-364250	3-IC5	ES-349367	6-SW10
ED-344280	2-D6	EH-355561	3-CR1	EI-364253	3-IC16	ES-349367	6-SW3
ED-344280	2-D9	EH-355561	3-CR2	EI-364257	3-X1	ES-349367	6-SW7
ED-344280	2-D10	EI-302233	2-IC4	EI-364273	3-IC6	ES-349367	6-SW2
ED-344280	2-D11	EI-302233	2-IC3	EI-364275	3-IC19	ES-349367	6-SW21
ED-344280	2-D12	EI-302233	5-IC1	EI-364308	4-IC8	ES-349367	6-SW13
ED-344280	2-D13	EI-302233	5-IC2	EI-364308	4-IC4	ES-349367	6-SW14
ED-344280	2-D14	EI-302233	6-IC1	EI-364319	2-IC1	ES-349367	6-SW12
ED-344280	2-D15	EI-310036	2-IC28	EI-364319	2-IC2	ES-349367	6-SW15
ED-344280	2-D16	EI-310036	2-IC29	EI-364378	2-IC45	ES-349367	6-SW9
ED-344280	2-D17	EI-310036	2-IC30	EI-364378	2-IC44	ES-349367	6-SW18
ED-344280	2-D18	EI-337228	4-IC1	EI-364674	3-IC7	ES-349367	6-SW5
ED-344280	2-D19	EI-337228	4-IC2	EJ-353031	4-J3	ES-364255	3-SW1
ED-344280	2-D7	EI-337228	4-IC3	EJ-358633	10-J901	ES-364478	10-SW902
ED-344280	2-D8	EI-337228	4-IC6	EJ-358691	3-1	ET-348302	4-TR8
ED-346463	2-D2	EI-337228	4-IC7	EJ-360771	2-J1	ET-348302	4-TR2
ED-357038	7-D2	EI-337228	4-IC10	EJ-363001	2-1	ET-348302	4-TR1
ED-357754	7-D3	EI-337228	4-IC11	EJ-364256	3-J5	ET-348302	4-TR5
ED-357754	7-D5	EI-337228	4-IC13	EJ-364322	3-J3	ET-348302	4-TR18
ED-357754	7-D6	EI-348123	7-IC4	EJ-364322	3-J4	ET-349081	2-TR5
ED-357754	7-D12	EI-353227	4-IC12	EJ-364322	3-J1	ET-349081	2-TR14
ED-359863	5-D5	EI-354146	3-IC10	EJ-364322	3-J2	ET-349081	2-TR15
ED-359863	5-D6	EI-354149	3-IC4	EM-364260	5-LN1	ET-349592	2-TR2

AX60

PART NO.	REF. NO.	PART NO.	REF. NO.	PART NO.	REF. NO.	PART NO.	REF. NO.
ET-349592	2-TR3	SK-364216A	11-2				
ET-349592	2-TR1	SK-364216B	11-3				
ET-349592	3-TR1	SK-364218	11-4				
ET-349608	3-TR3	SK-364218B	11-5				
ET-349608	3-TR2	SK-364219	11-6				
ET-352994	4-TR9	SP-354550	9-2				
ET-352994	4-TR10	ZG-354553	9-4				
ET-352994	4-TR14	ZS-201778	10-9				
ET-353899	4-TR7	ZS-310984	9-5				
ET-353899	4-TR15	ZS-341960	10-6				
ET-353899	4-TR6	ZS-344754	10-4				
ET-353899	4-TR11	ZS-350934	10-16				
ET-353899	5-TR2	ZS-354230	10-8				
ET-353899	5-TR1	ZS-355511	10-17				
ET-353899	5-TR3	ZS-362286	10-5				
ET-353899	6-TR4	ZS-411232	10-13				
ET-353899	6-TR2	ZW-273892	10-15				
ET-353899	6-TR5	ZW-273914	10-11				
ET-353899	6-TR3	ZW-274026	10-10				
ET-353899	6-TR1	ZW-413267	10-14				
ET-354083	7-TR2	ZW-632226	7-2				
ET-356817	7-TR3	ZW-698308	10-12				
ET-356817	7-TR1						
ET-360067	2-TR4						
ET-360067	3-TR4						
ET-360067	4-TR16						
ET-360067	4-TR3						
ET-360067	4-TR17						
ET-360067	4-TR4						
ET-360067	4-TR13						
ET-360067	4-TR12						
ET-360067	7-TR6						
ET-360067	7-TR4						
ET-360067	7-TR5						
ET-364560	3-PH1						
EV-307709	3-VR1						
EV-336770	2-VR7						
EV-336770	2-VR8						
EV-354253	9-VR904						
EV-354254	9-VR907						
EV-358043	9-VR905						
EV-358043	9-VR906						
EV-358829	4-VR2						
EV-358829	4-VR1						
EV-364267	5-VR1						
EV-364267	5-VR8						
EV-364267	5-VR7						
EV-364267	5-VR6						
EV-364267	5-VR13						
EV-364267	5-VR3						
EV-364267	5-VR11						
EV-364267	5-VR2						
EV-364267	5-VR5						
EV-364267	5-VR14						
EV-364267	5-VR10						
EV-364267	5-VR12						
EV-364267	5-VR4						
EV-364267	5-VR9						
EV-364267	6-VR3						
EV-364267	6-VR1						
EV-364267	6-VR4						
EV-364267	6-VR2						
EV-364276	6-VR7						
EV-364277	6-VR6						
EV-364321	4-VR3						
EV-364326	7-VR1						
EW-358630	10-1D						
EW-358631	10-1C						
EW-358858	10-1A						
EW-359641	10-1B						
EW-524845	10-1						
EZ-200473	7-1						
EZ-302906	10-2A						
EZ-358816	3-BT1						
EZ-631945	10-2						
MI-354552	9-3						
SA-332850	10-3						
SC-364225	11-8						
SK-B352952X4	9-1						
SK-322105	11-7						

MEMO

AKAI

MODEL AX60

SECTION 3

SCHEMATIC DIAGRAM AND PC BOARD

TABLE OF CONTENTS

1. POWER PC BOARD	2
2. CONNECTION DIAGRAM	3
3. CONTROL BLOCK DIAGRAM.....	4
4. VOICE AND CHORUS BLOCK DIAGRAM.....	5
5. CPU DIAGRAM.....	6
6. CPU PC BOARD	7
7. VOICE PC BOARD	8
8. VOICE DIAGRAM.....	9
9. OPERATION DIAGRAM.....	10
10. OPERATION (A), (B) PC BOARD.....	11
11. CHORUS DIAGRAM	12
12. CHORUS PC BOARD.....	13
13. LOCATION OF ICs.....	14

This Manual is FOR INTERNAL USE ONLY and must not be made available to unauthorized personal. No part of this manual may be reproduced in any form without permission from AKAI-ELECTRIC CO., LTD., Tokyo, Japan.

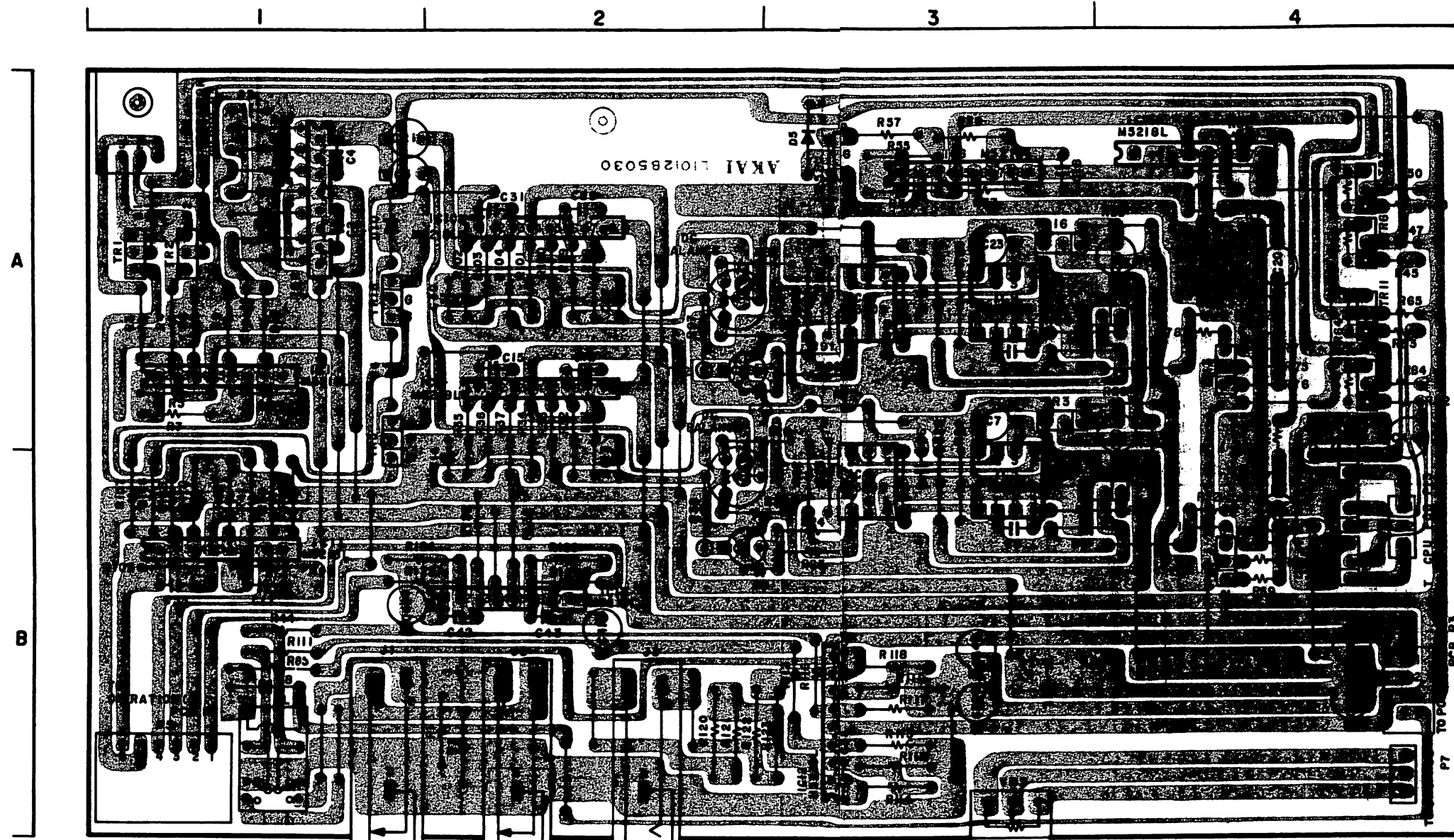

CHORUS PCB LI012B5030

= PNP TRANSISTOR

= NPN TRANSISTOR

- TR 1, 2, 5, 8, 18 ----- 2SK381 (C, D)
- TR 3, 4, 12, 13, 16, 17 ----- 2SC3330 (T, U)
- TR 6, 7, 11, 15 ----- 2SA1317 (T, U)
- TR 9, 10, 14 ----- 2SC3401



2SK381



2SC3330
 2SA1317
 2SC3401

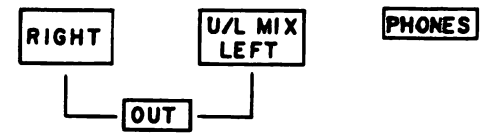

LOCATION OF COMPONENTS

IC's	TR's	CONNECTORS
IC1---A1	TR1---A1	P1---A1
IC2---A1	TR2---A1	P3---B4
IC3---A2	TR3---A3	P5---B1
IC4---B3	TR4---B3,4	W8---B4
IC5---B3	TR5---A,B1	W9---B4
IC6---A3	TR6---A4	
IC7---A4	TR7---A4	
IC8---A3	TR8---A3	
IC9---A3	TR9---A,B4	
IC10---A2	TR10---B4	
IC11---B1	TR11---A4	
IC12---B3	TR12---B4	
IC13---B2	TR13---A4	
	TR14---B4	
	TR15---A4	
	TR16---A3	
	TR17---A3,4	
	TR18---A1	

LOCATION OF COMPONENTS

IC's

- IC1---G1
- IC2---G2
- IC3---G3
- IC4---G4
- IC5---G1
- IC6---G1
- IC7---G1
- IC8---G2
- IC9---G2
- IC10---G2
- IC11---G2
- IC12---G2,3
- IC13---G3
- IC14---G3
- IC15---G3
- IC16---G3,4
- IC17---G3,4
- IC18---G4
- IC19---G4
- IC20---F,G4
- IC21---E1
- IC22---A,2
- IC23---B,2
- IC24---C,2
- IC25---D,2
- IC26---D,2
- IC27---E,2
- IC28---A,2
- IC29---C,2
- IC30---E,2
- IC31---A,2,3
- IC32---B,2,3
- IC33---C,2,3
- IC34---D,2,3
- IC35---D,2,3
- IC36---E,2,3
- IC37---A,B,3
- IC38---C,3
- IC39---E,3
- IC40---E,4
- IC41---D,4
- IC42---C,4
- IC43---A,B,4
- IC44---B,4
- IC45---A,4

TR's

- TR1---G2
- TR2---G2
- TR3---G3
- TR4---E,F,1
- TR5---F,1
- TR14---D,E,4
- TR15---E,4

CONNECTORS

- P1---G3,4
- P3---G3
- P4---G1,2
- P5---A,4

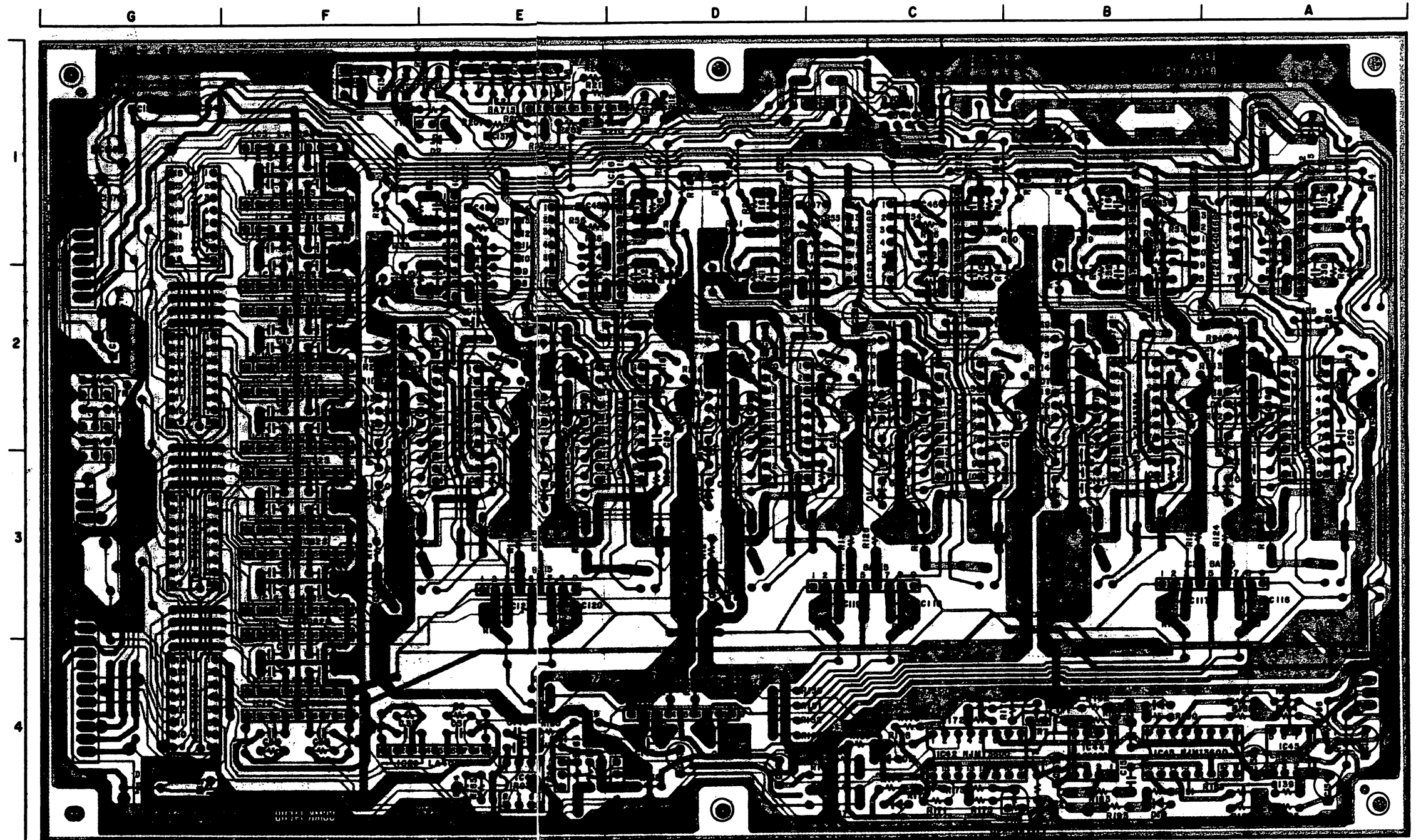



VOICE PCB L1012A5010

 NPN TRANSISTOR

- TR1 to 3 -----2SC3400
- TR4 -----2SC3330 (T,U)
- TR5,14,15 -----2SC3383 (S)

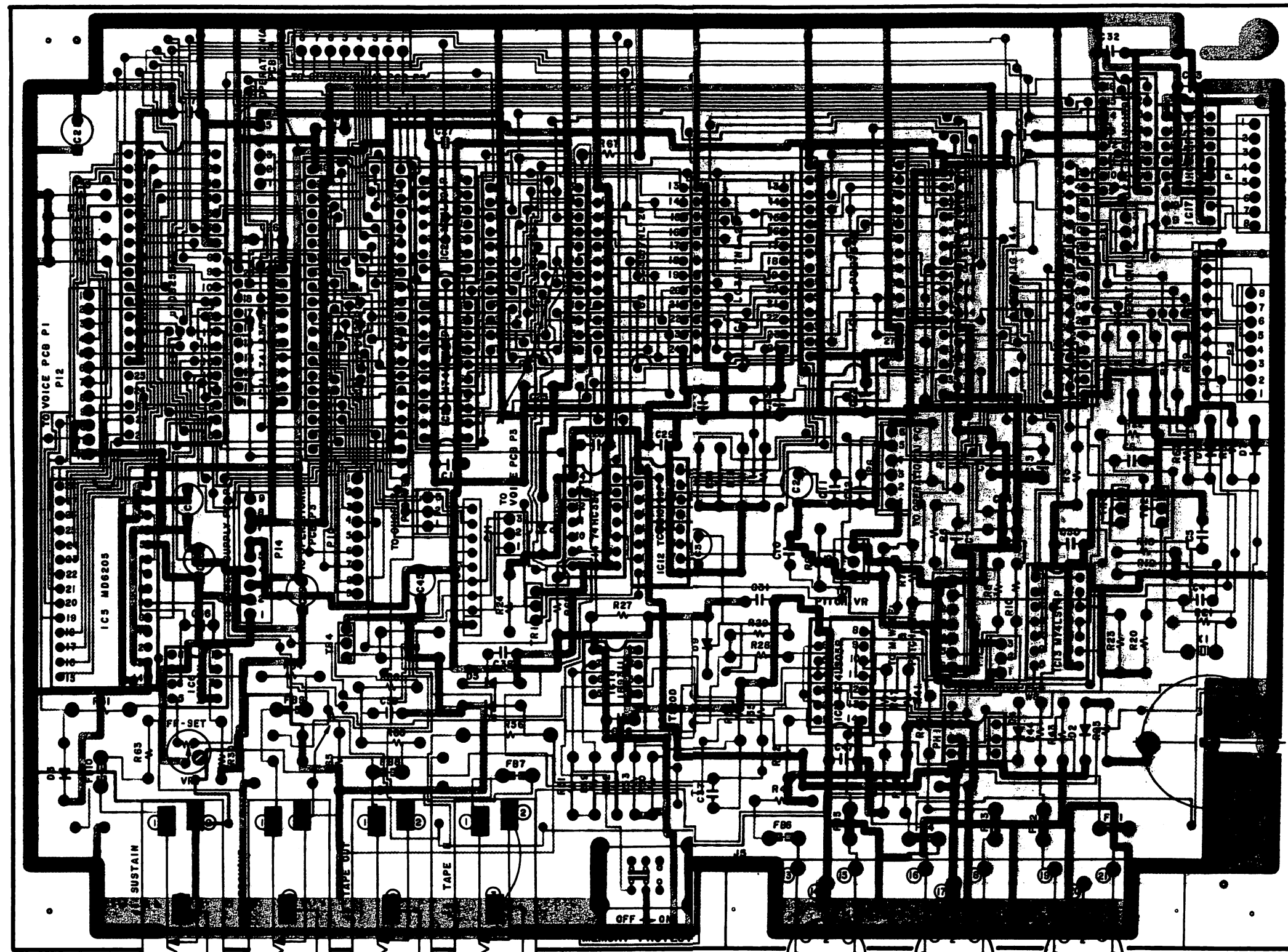



 EBC
 2SC3383

 ECB
 2SC3330
 2SC3400

 = NPN TRANSISTOR

TR1----2SC3400
 TR2,3---2SC3383

PEDAL SUSTAIN

ARPEGGIO EXT-SYNC

OUT
 TAPE
 IN

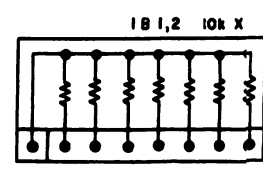

OUT
 THRU
 IN
 MIDI

CPU PCB
L1012A5020

74LS04	Hex Inverter
74LS05	Hex OC Inverter
74LS14N	Hex Schmitt Trigger Inverter
74HC32	Quad 2 Input OR gate
74LS38	Quad 2 Input OC NAND Buffer
74LS42	BCD to DECIMAL decoder
74HC138	3 to 8 Demultiplexer
74HC139	Dual 2 to 4 Demultiplexer
74LS373N	Octal 3 State D-Latches
BA715 (MS218L)	Dual Low Noise OP Amp
CEM3394	Controllable Signal Processor
IR9311 (MPC311)	Comparator
LA6082S (NJM082S)	Dual Low Noise OP Amp
LC3517NL	2K x 8 bit S RAM
LF356	Low Noise OP Amp
MS218L	Dual Low Noise OP Amp
MD6205	16 bit A/D. D/A Convertor
MN3009	256 stage Low Noise BBD
MN3101	BBD clock Generator/Driver
PST520D	Rest
TC4051BP	Single 8 channel Multiplexer/Demultiplexer
TC4066BP	Quad Bilateral Switch
uPD2764D	65.536 bit UV Erasable PROM
uPD8253	Programable Interval Timer
uPD8255AC-2	Programable Peripheral Interface
uPD8279C-5	Programable Key Board/Display Controller
uPD7811G	8 bit Micro Computer with A/D Convertor

74HC32

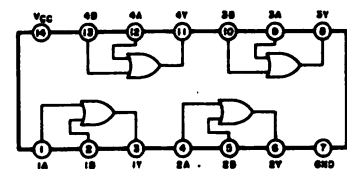

74HC38

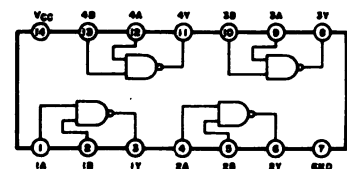

74HC138

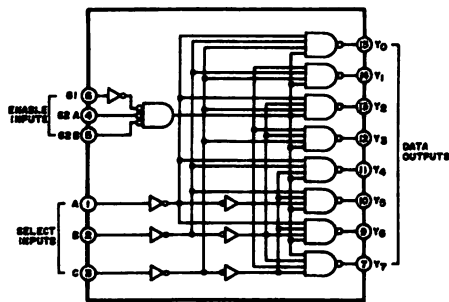

INPUTS			OUTPUTS			
ENABLE	SELECT		Y0	Y1	Y2	Y3
H	X	X	H	H	H	H
L	L	L	L	H	H	H
L	L	H	H	L	H	H
L	H	L	H	H	L	H
L	H	H	H	H	H	L

74HC139

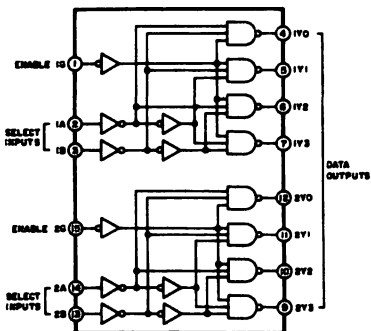

74LS04

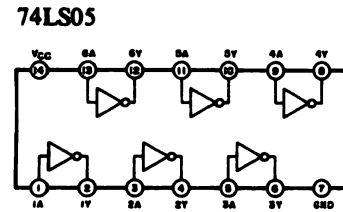

74LS14N

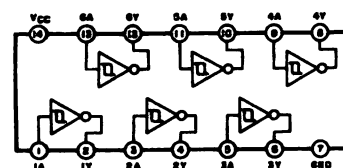

74LS373N

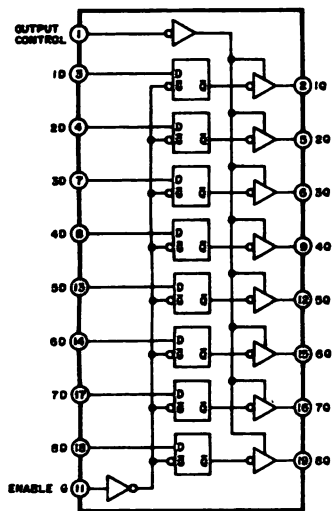

CEM3394

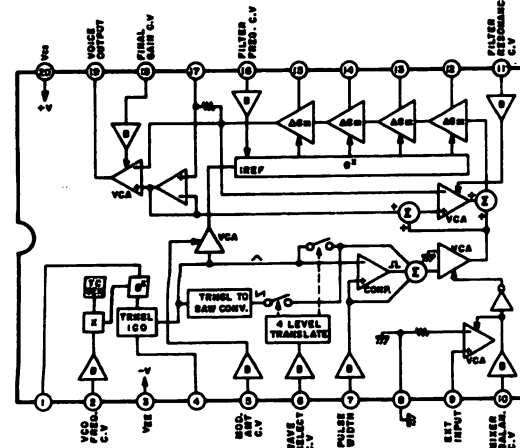

74LS42

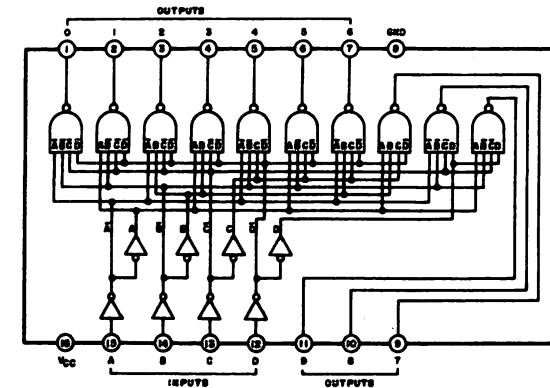

MD62705

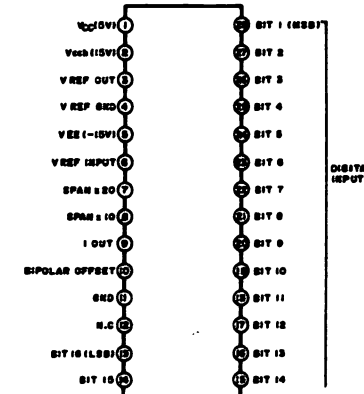

MN3009

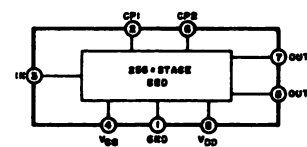

TC4066

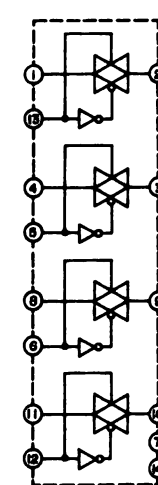

MN3101

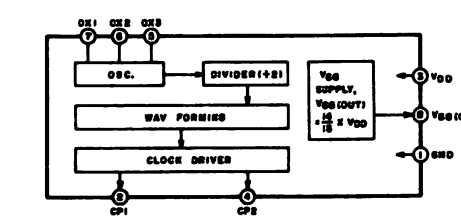

TC4051

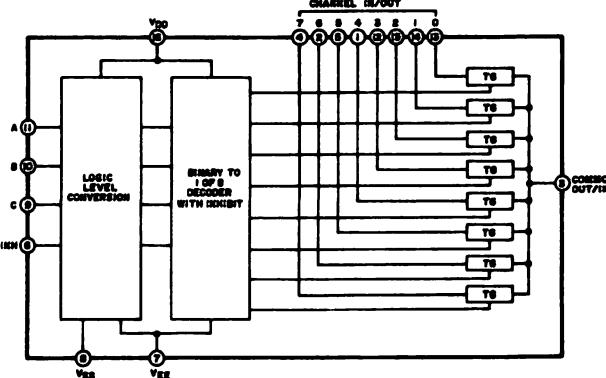

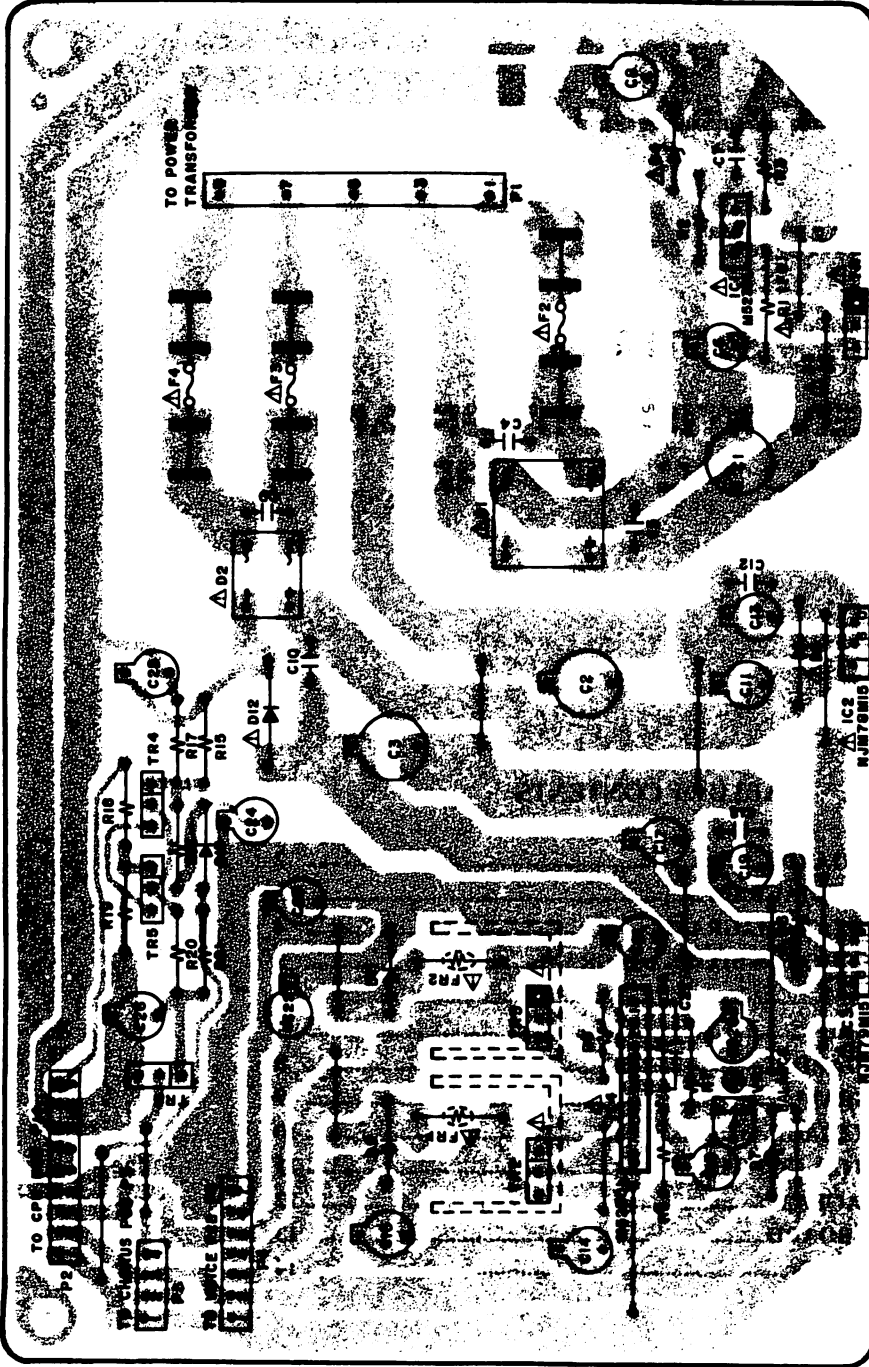

POWER SUPPLY PCB L1012B5050

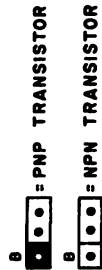

I: IN
O: OUT
G: GND

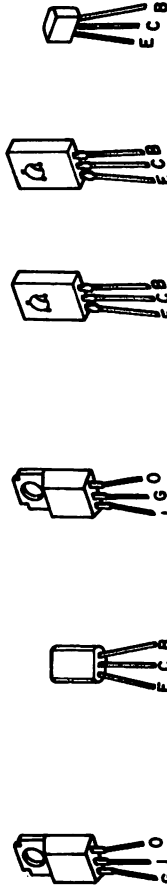

WARNING: Δ INDICATES SAFETY CRITICAL COMPONENTS FOR CONTINUED SAFETY.
 REPLACE SAFETY CRITICAL COMPONENTS ONLY WITH MANUFACTURER'S
 RECOMMENDED PARTS
 AVERTISSEMENT: Δ IL INDIQUE LES COMPOSANTS CRITIQUES DE SÉCURITÉ.
 POUR MAINTENIR LE DEGRÉ DE SÉCURITÉ DE L'APPAREIL,
 NE REMPLACER QUE DES PIÈCES RECOMMANDÉES PAR LE FABRICANT

SECTION 4

SERVICE BULLETIN

- This section describes the information on techniques revisions and troubleshooting for servicing and adjusting AX60.
- To maintain the performance of AX60, see also AX60 Service Manual for servicing and adjustment.
- Further technical information will be issued as any arises.
Keep such information carefully under the name of this file.

This Manual is FOR INTERNAL USE ONLY and must not be made available to unauthorized personal. No part of this manual may be reproduced in any form without permission from AKAI-ELECTRIC CO., LTD., Tokyo, Japan.

MODEL: AX60

No. MS-0008

DATE: March 1986

001 Subject: To improve performance

The ROM IC program has been changed to improve the following points.

1. AUTO TUNE request by MIDI is recognized but is not transmitted.
2. AUTO MUTE request by AUTO MUTE button is accepted up to 6 times causing other functions inoperative for up to 30 - 35 seconds.
3. When VERIFY is executed and the data recorded on the tape and that of AX60 is different whatever the reason may be, the data in AX60 may be re-written when PROTECT switch is off.
4. Since the position of PITCH BEND setting VR is memorized when the unit is turned off, when the unit is turned on again after changing the position of setting VR, the amount of Pitch Bend effect is different from its VR position.
5. In SPLIT mode, the MIDI channels are set for Upper keys and Lower Keys separately. But even after SPLIT mode is released, MIDI channels are not canceled thus AX60 accepts 2 MIDI channels.

	Ref. No.	Part No.	Description
(NEW)	3-IC7	EI-364674	IC TMM2764ADC AX60 V1.2

Changed from : January 1986

Service Ref. No. : CNL0101, CNL0113

MODEL: AX60

No. MS-0008

DATE: March 1986

002 Subject: Standardization of parts

In order to accommodate the same power supply P.C. Board as of AX73, the circuit has been changed as follows.

	Ref. No.	Part No.	Description
(FORMER)	7-R7	ER-364324	R MF H 1/4W 14K
(NEW)	7-R7Z	ER-305128	R MF H 1/4W 15K
(FORMER)	7-VR1Z	EV-364326	R S-FIX 2.2K
(NEW)		Deleted	

Changed from : April 1986

Service Ref. No. : CNA1861

MODEL: AX60

INDEX

Bulletin No.	Subject No.	Description
MS0008	001	ROM IC Change
	002	Standardization-Power Supply

IX60

05

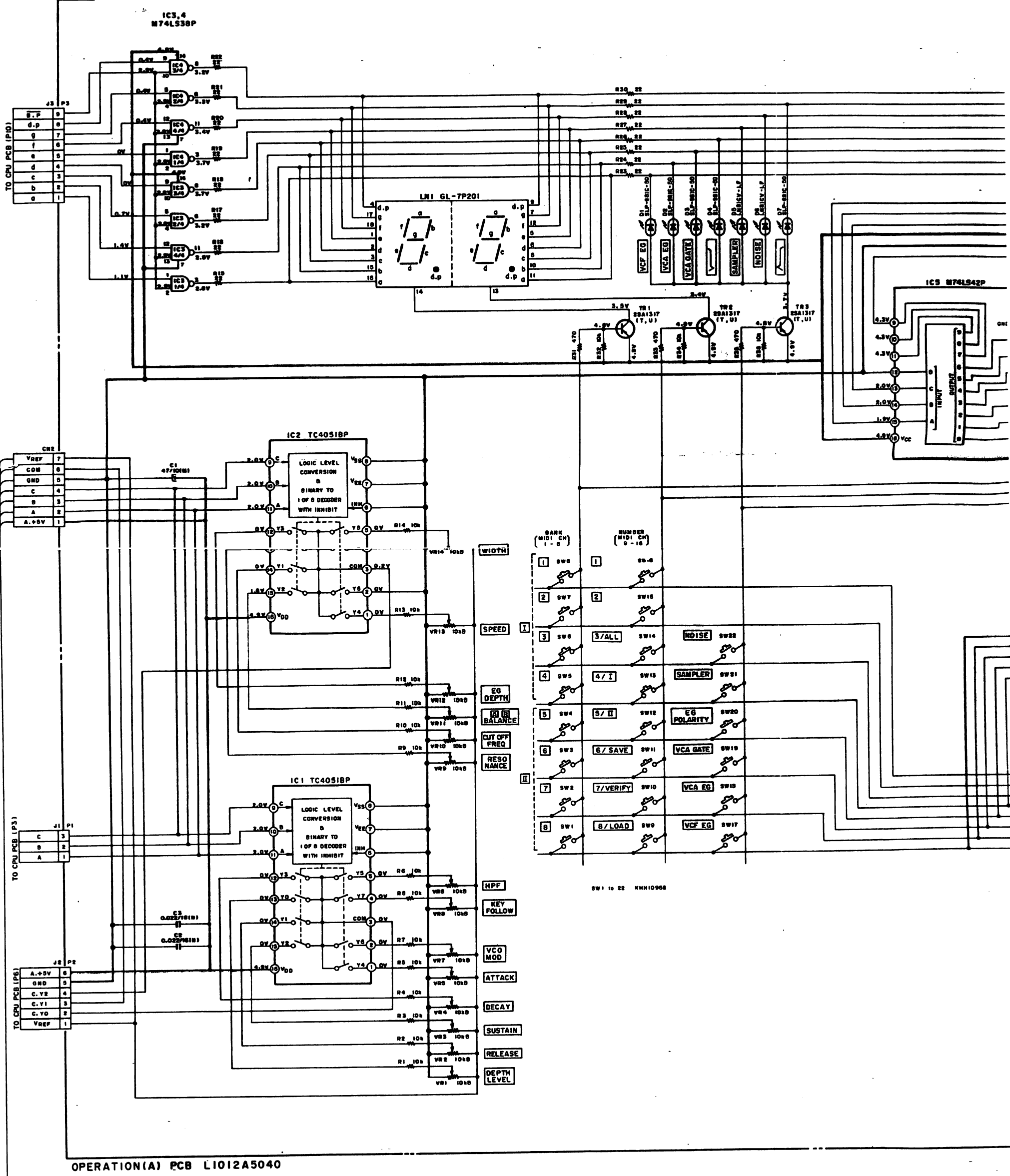

OPERATION(A) PCB L1012A5040

GND (POWER SUPPLY) LINE

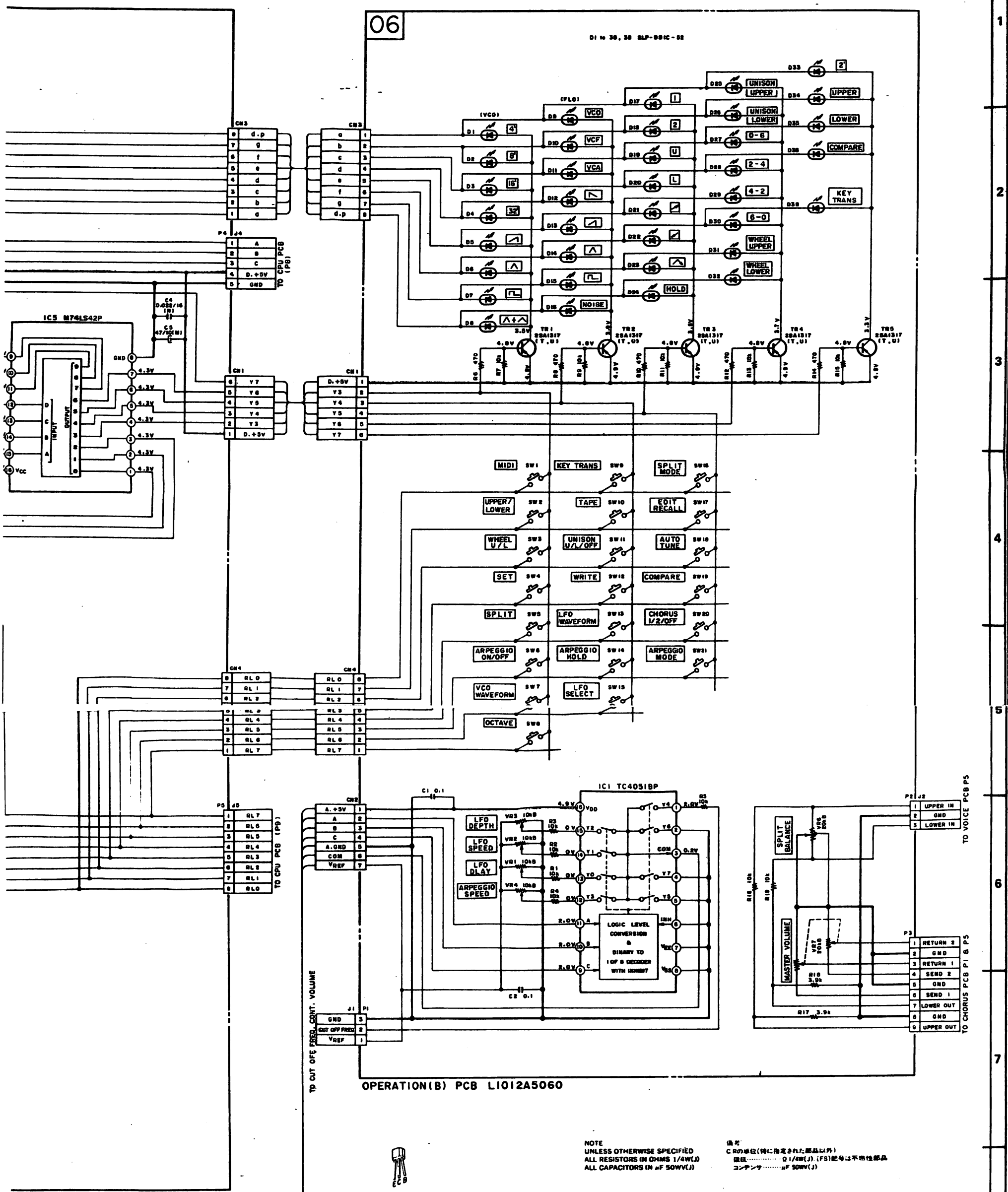

06

DI No 36, 38 SLP-881C-88

OPERATION(B) PCB LI012A5060

NOTE
 UNLESS OTHERWISE SPECIFIED
 ALL RESISTORS IN OHMS 1/4W(J)
 ALL CAPACITORS IN μF 50WV(J)

備考
 C.Rの単位(特に指定された部品以外)
 抵抗 Ω / 4W(J) (FS記号は不燃性部品)
 コンデンサ μF 50WV(J)



AX60
 OPERATION(A)/(B)
 SCHEMATIC DIAGRAM
 No.5-3 860214A

AX60

04

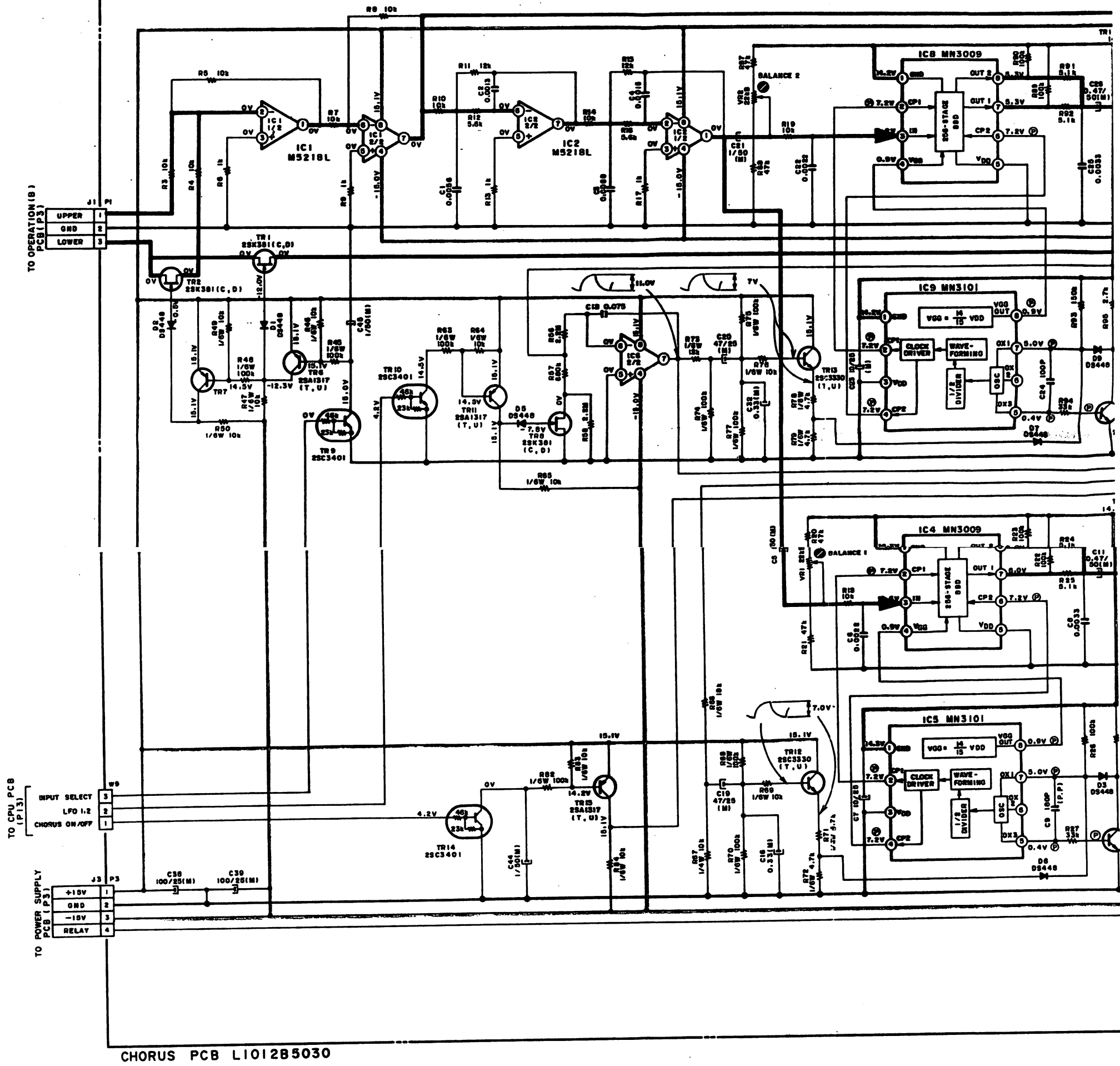

CHORUS PCB L1012B5030

 :電源 B (POWER SUPPLY) LINE
 SIGNAL LINE



2SK381



2SA1317
 2SC3330
 2SC3401

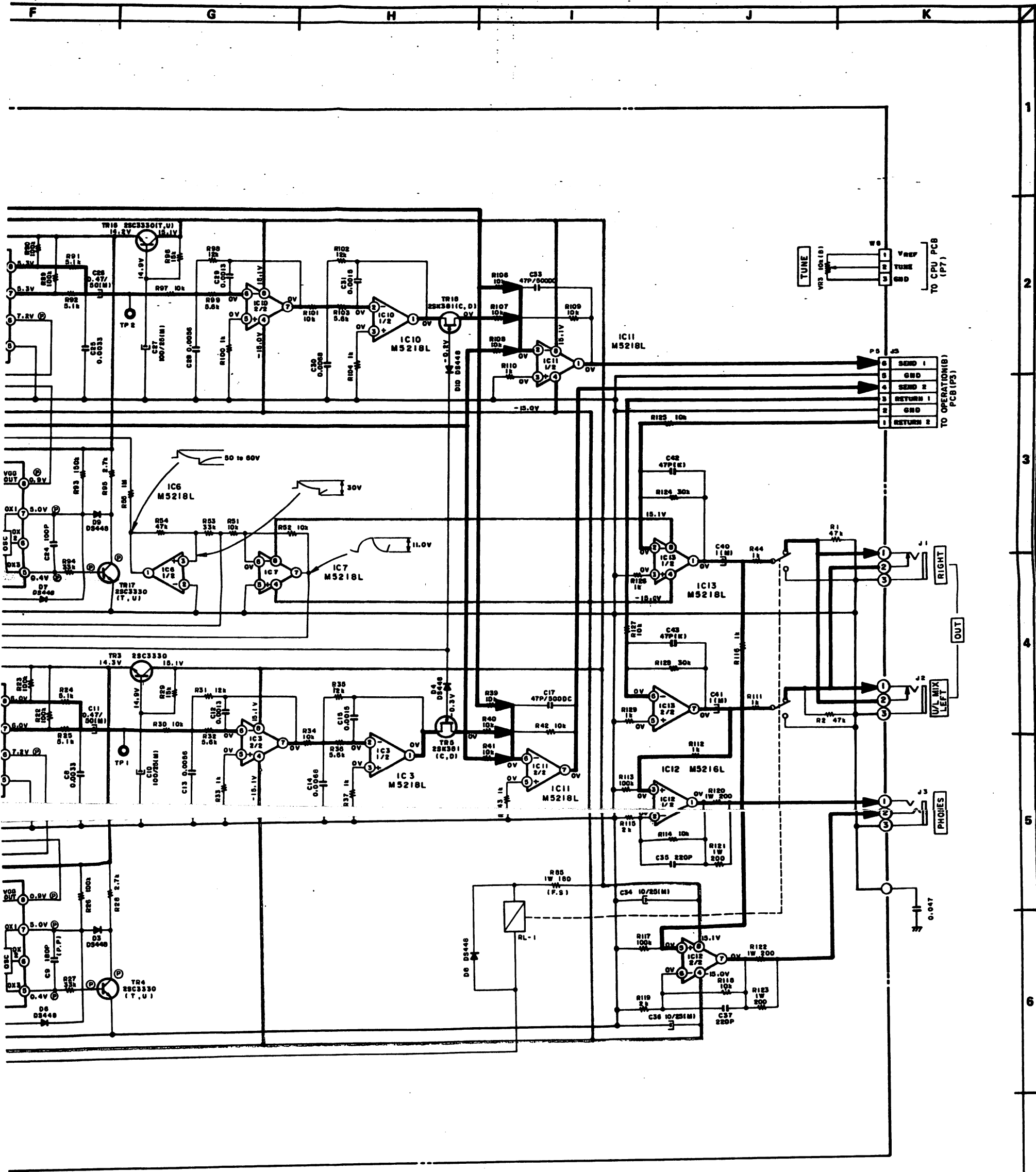

INDICATED VOLTAGES ARE MEASURED AT CHORUS "1" MODE
 ⊕ = PULSE

NOTE
 UNLESS OTHERWISE SPECIFIED
 ALL RESISTORS IN OHMS 1/4W(J)
 ALL CAPACITORS IN μF 50WV(J)

備考
 C.Rの単位(特に指定された部品以外)
 抵抗.....Ω 1/4W(J), (FS)記号は不燃性部品
 コンデンサ.....μF 50WV(J)



2SA1317
 2SC3330
 2SC3401

AX60 CHORUS SCHEMATIC DIAGRAM

No.5-5 860216A

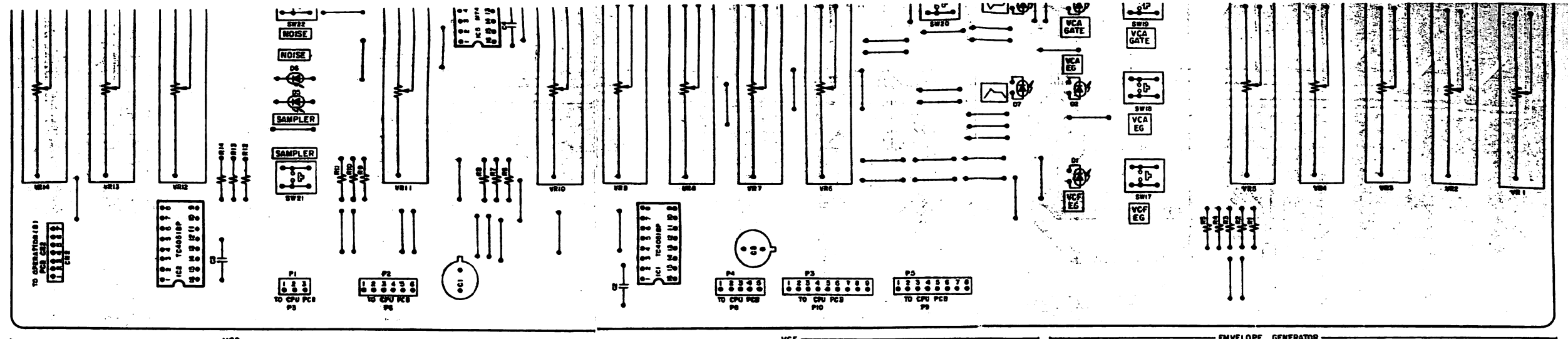

OPERATION (A) PCB LI012A5040

TRI, 2, 3
25A1317

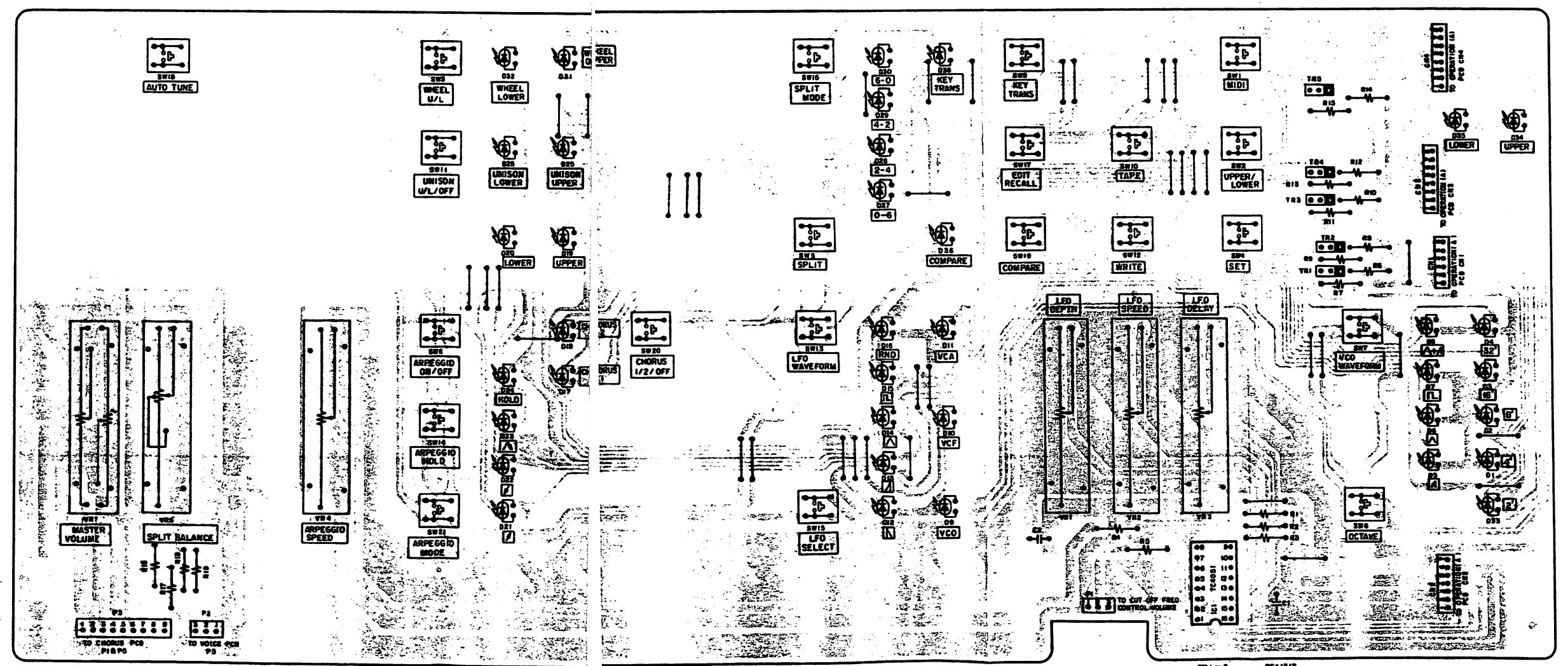

OPERATION (B) PCB LI012A5060

TRI 1 to 5
25A1317

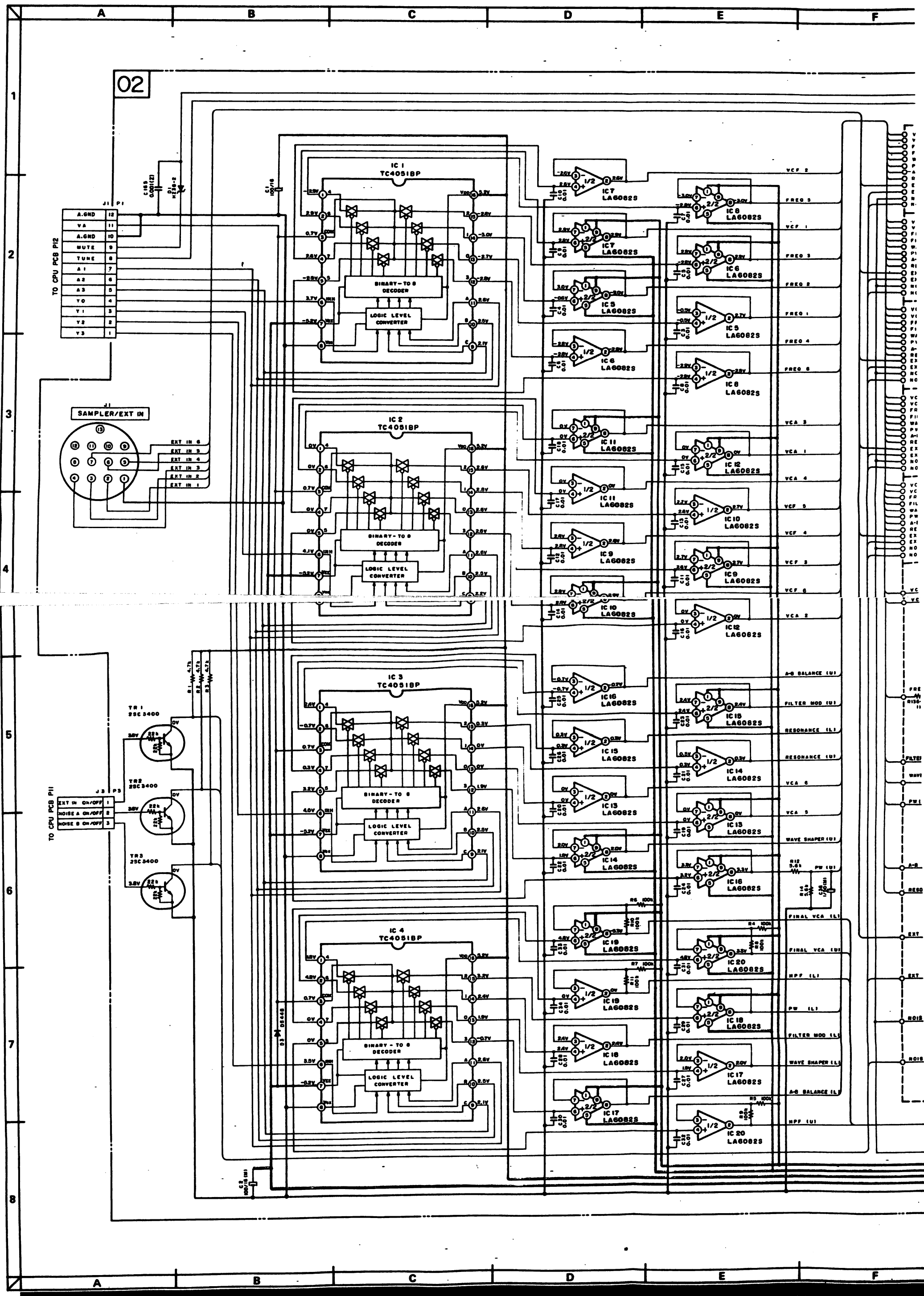

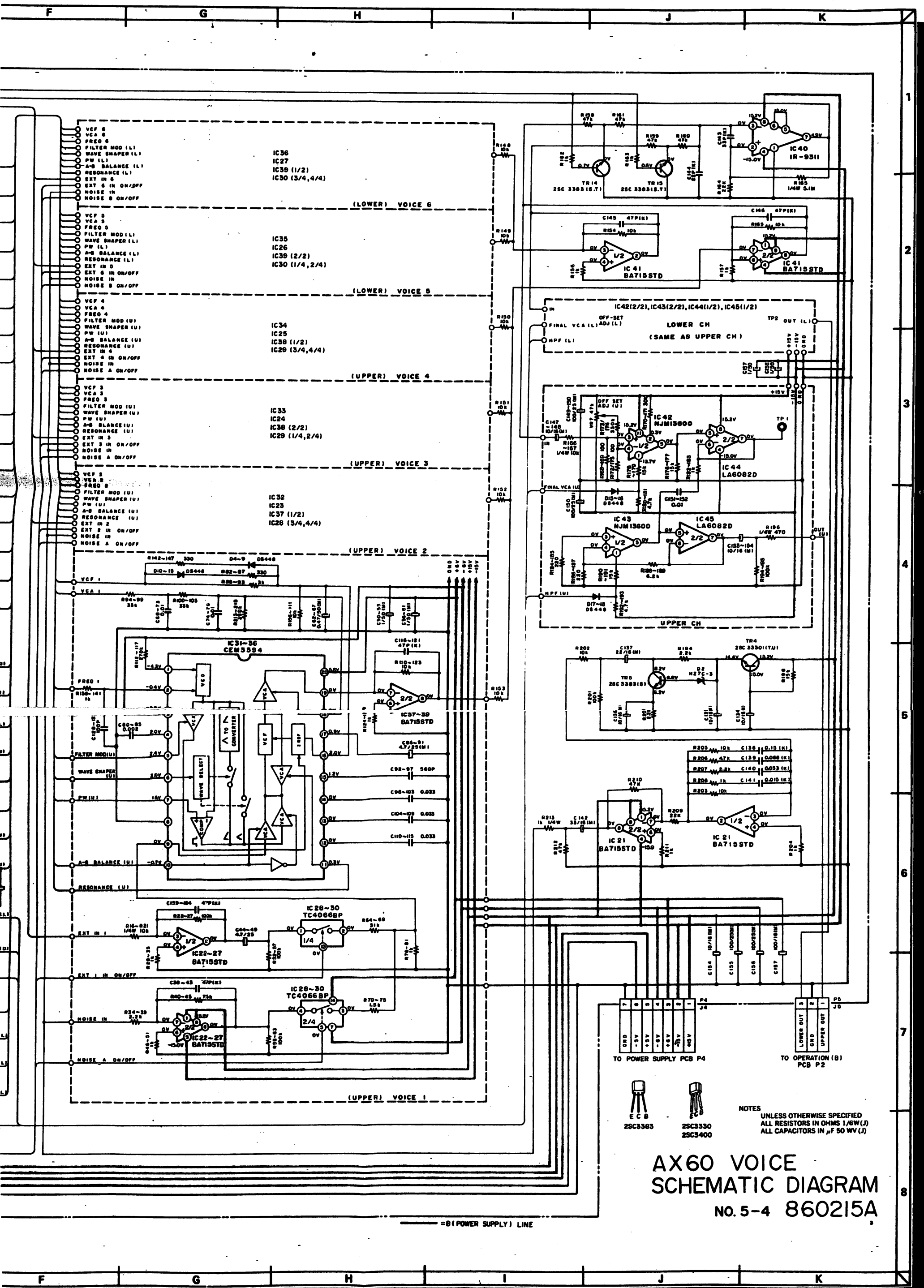

AX60 VOICE SCHEMATIC DIAGRAM

No. 5-4 860215A

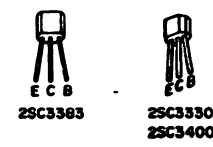

NOTES
UNLESS OTHERWISE SPECIFIED
ALL RESISTORS IN OHMS 1/6W(J)
ALL CAPACITORS IN μ F 50 WV(J)

-B(POWER SUPPLY) LINE

1
2
3
4
5
6
7
8

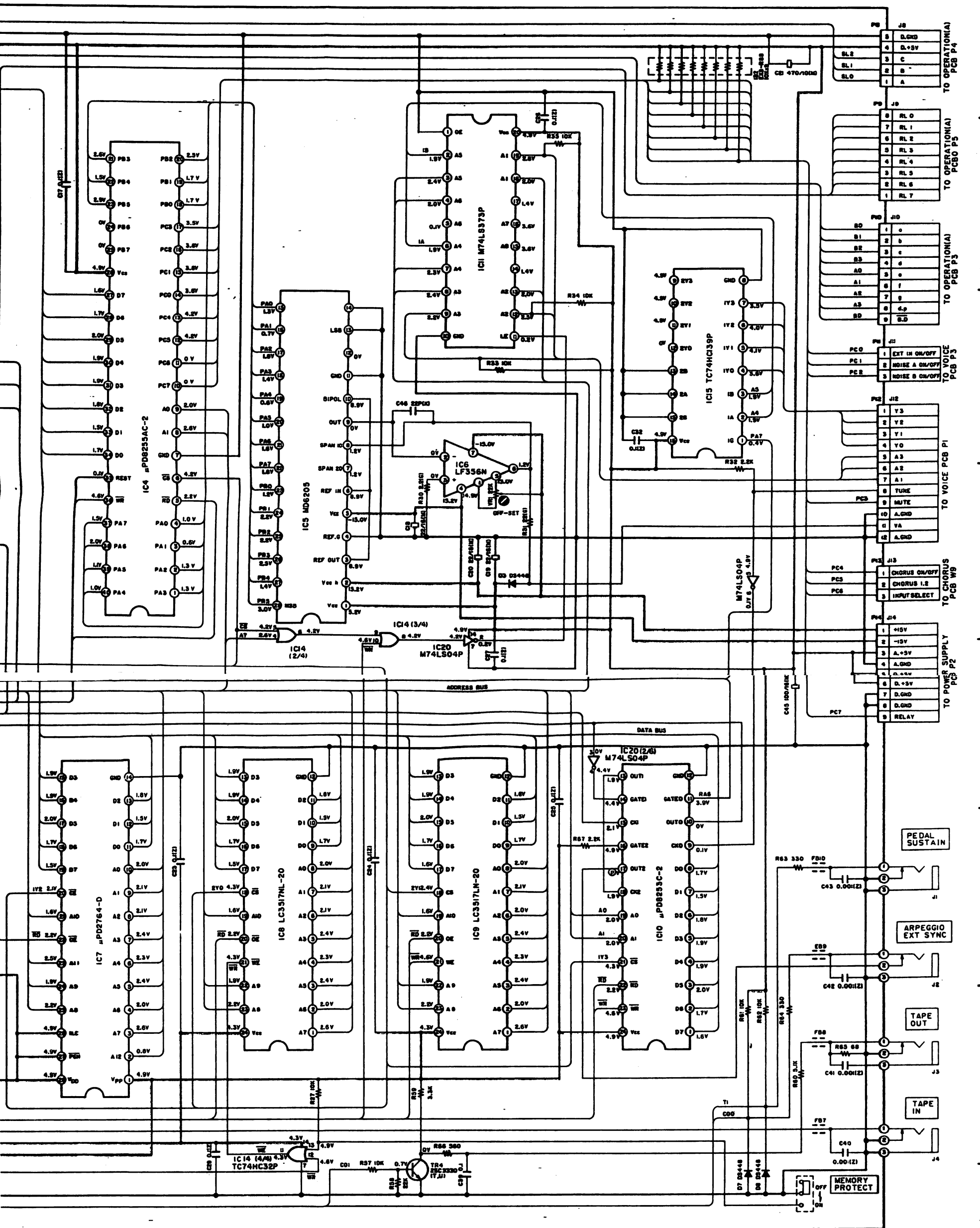

1
2
3
4
5
6
7
8

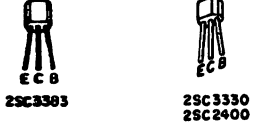

CPU PCB L1012A5020

NOTES
 UNLESS OTHERWISE SPECIFIED
 ALL RESISTORS IN OHMS 1/6W(J)
 ALL CAPACITORS IN μ F 50 WV (J)

AX60 CPU
 SCHEMATIC DIAGRAM
 No.5-2 860213A

A B C D E F

1
2
3
4
5
6
7
8

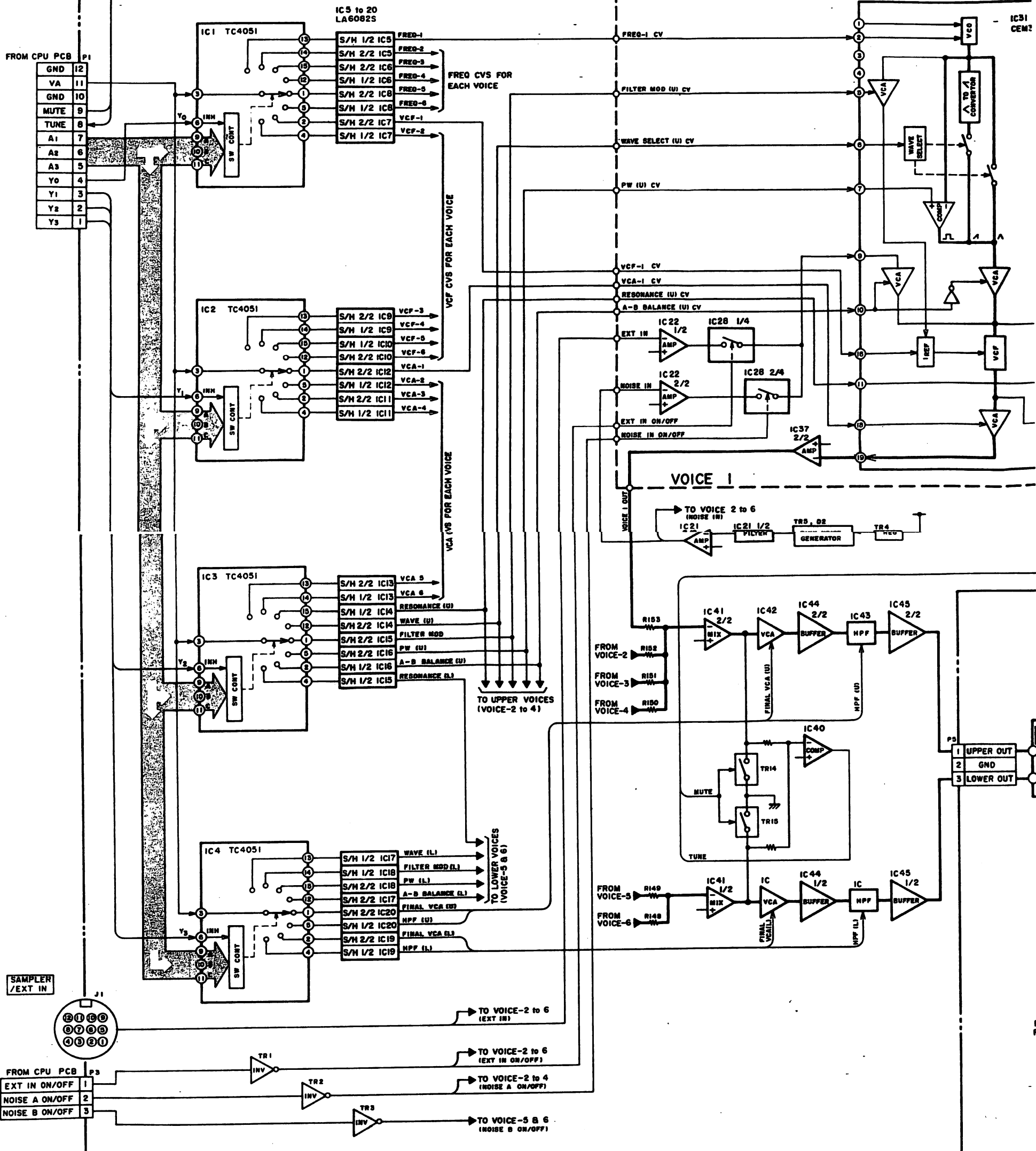

VOICE PCB LI012A5010

A B C D E F

8

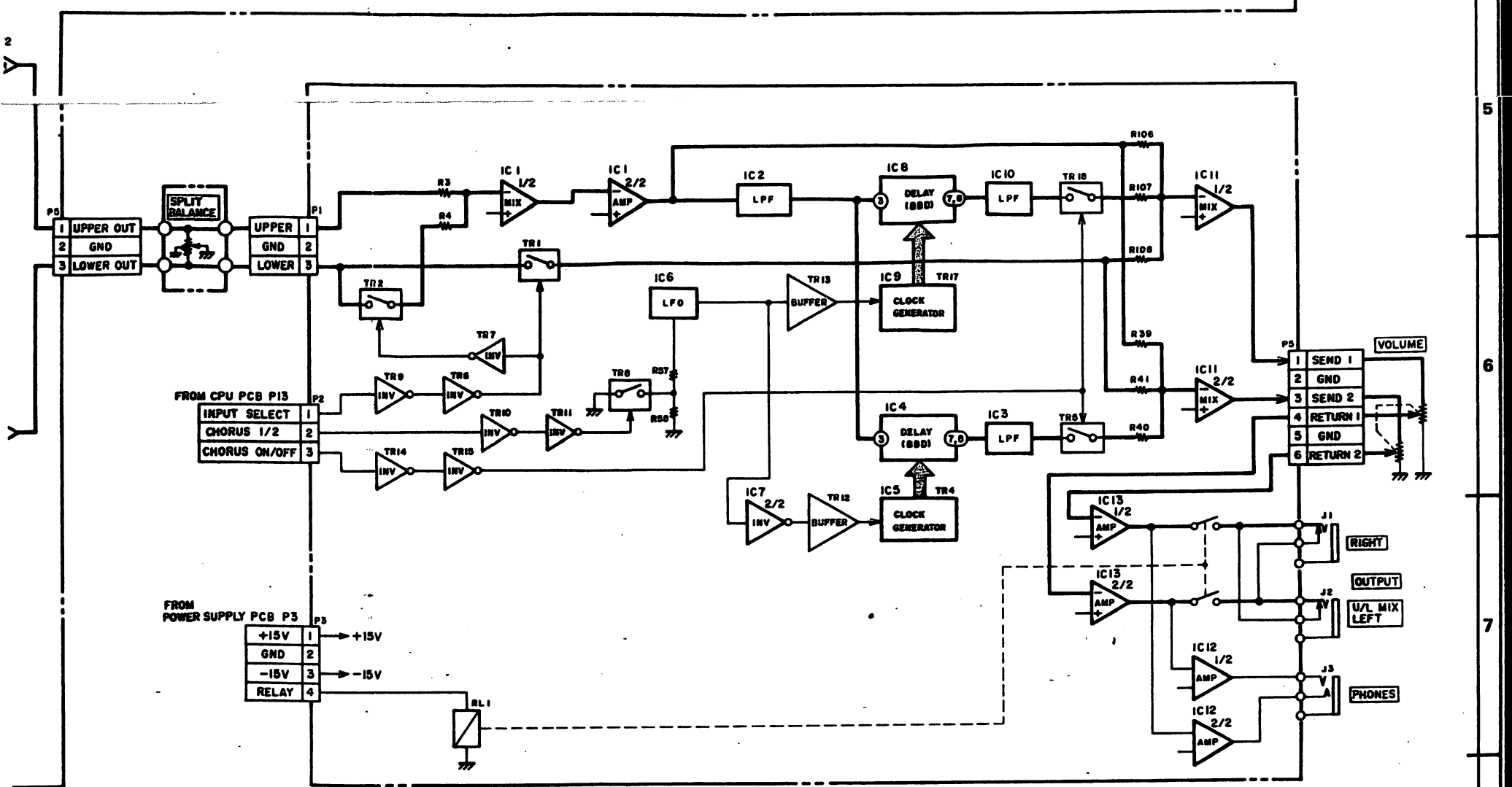
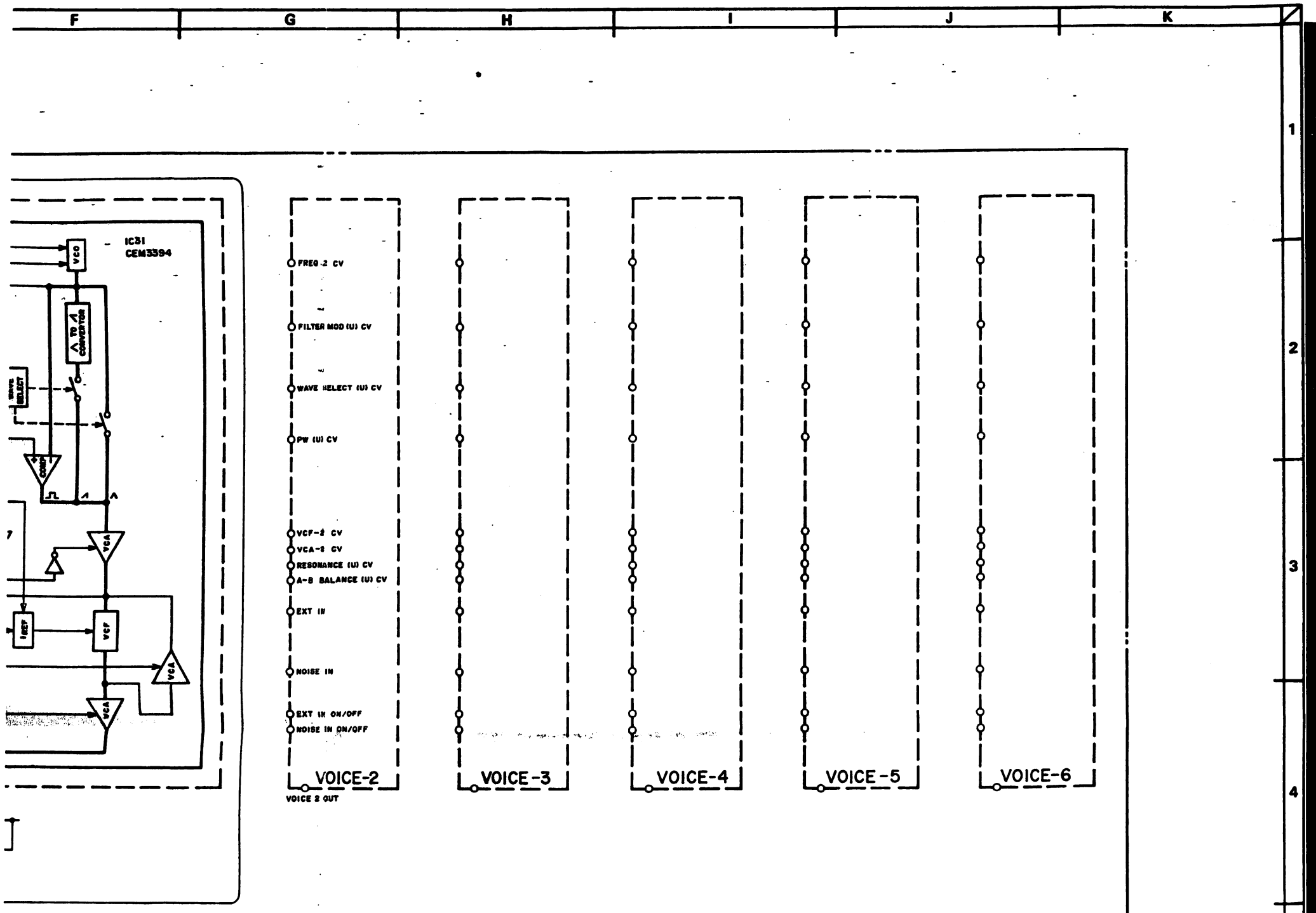

CHORUS PCB L1012B 5030

AX60
VOICE & CHORUS
BLOCK DIAGRAM
No.2-2 860211A



1
2
3
4
5
6
7
8

OPERATION (A) PCB L1012A5040

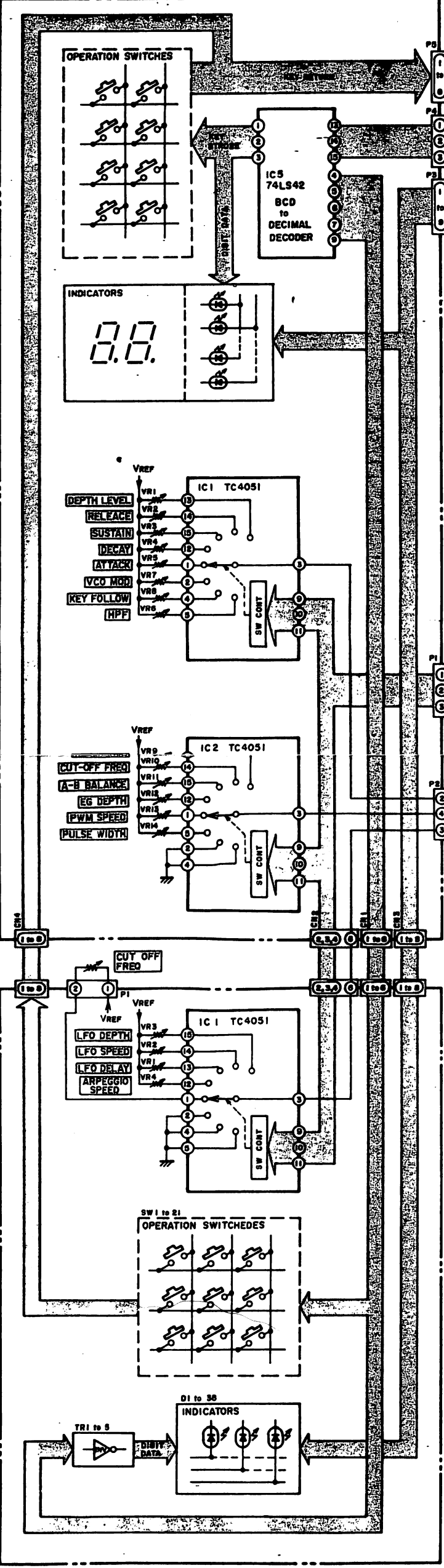

OPERATION (B) PCB L1012A5060

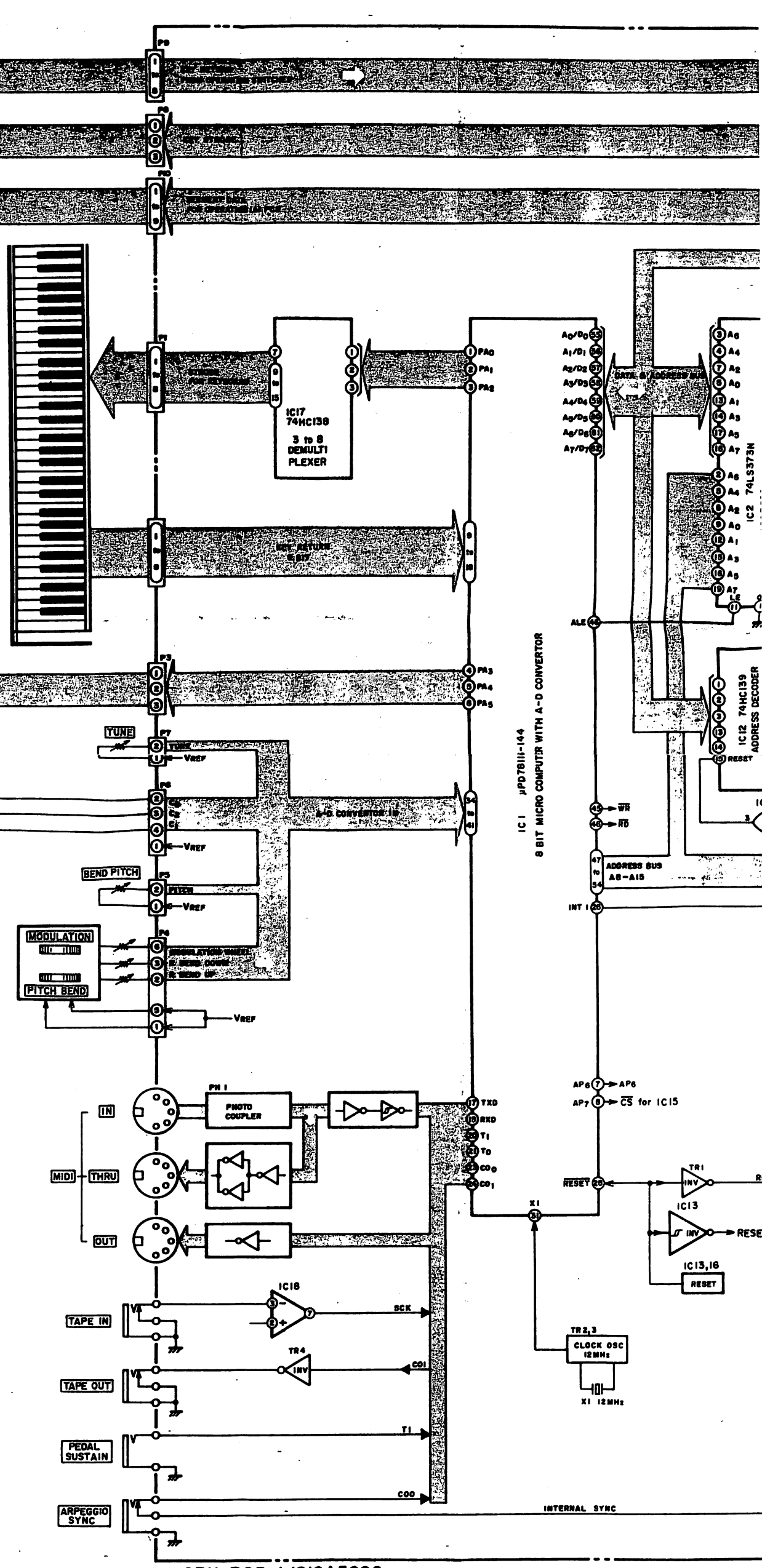

CPU PCB L1012A5020

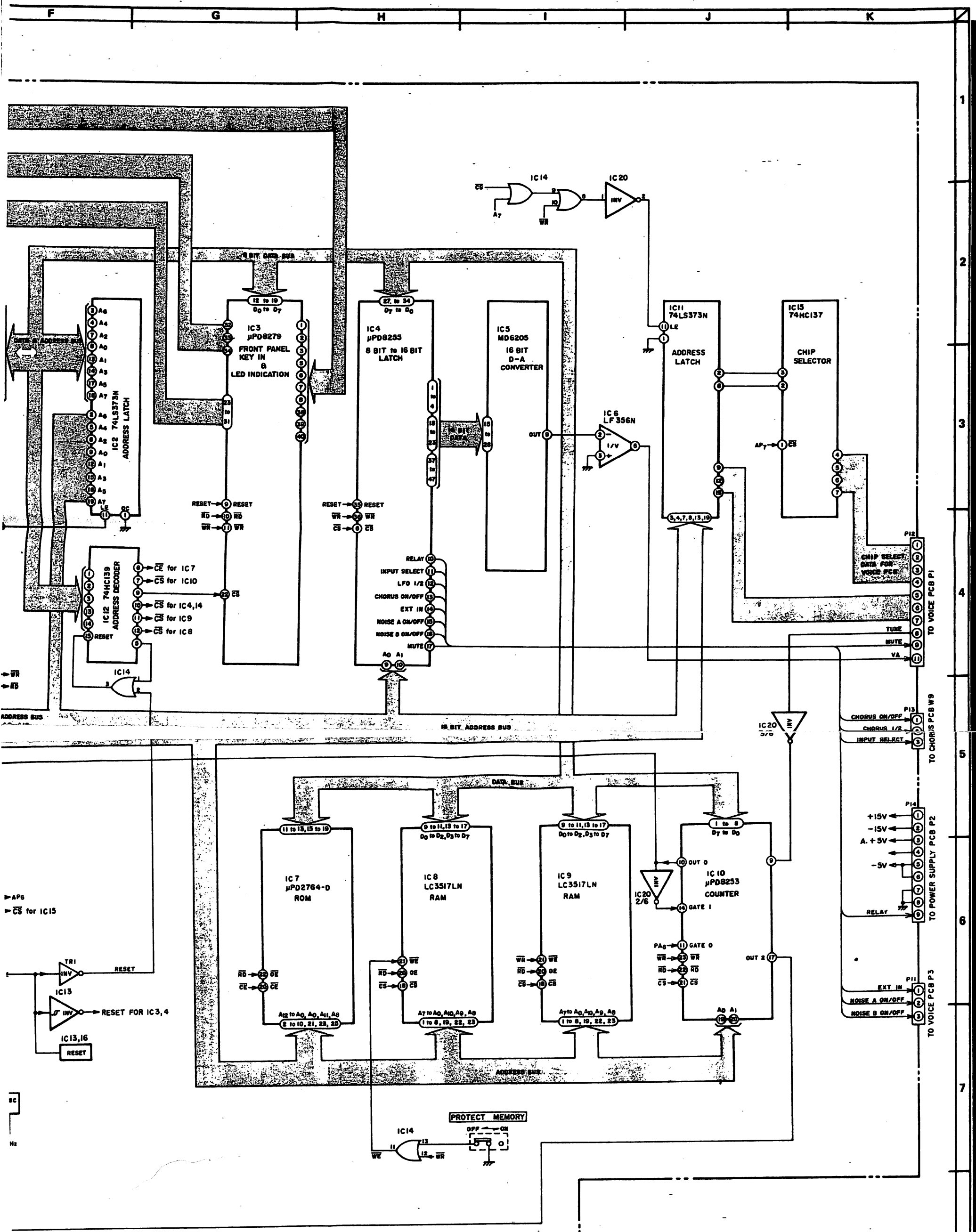

AX60 CONTROL
BLOCK DIAGRAM
NO.2-1 860210A

