



Panasonic®

Operating Instructions

CD Stereo System

Model No. **SC-PM31**
SC-PM313

SC-PM31 is used in the illustrations unless otherwise mentioned.



For U.S.A.

As an ENERGY STAR® Partner, Panasonic has determined that this product meets the ENERGY STAR® guidelines for energy efficiency.



Before connecting, operating or adjusting this product, please read these instructions completely. Please keep this manual for future reference.

SC-PM313 is available in the U.S.A. only

Operations in these instructions are described mainly using remote control, but you can do the operations on the main unit if the controls are the same.

Table of contents

IMPORTANT SAFETY INSTRUCTIONS	3
Product Service	3
Listening caution	3
Supplied accessories	3
Getting started	4
Step 1 - Making the connections	
Step 2 - Inserting batteries into the remote control	
Step 3 - DEMO function	
Placement of speakers	
Overview of controls	6
Main unit	
Remote control	
CDs and MP3 – Play	7
Playing a disc	
Advanced CDs and MP3 functions	
Cassette tapes – Play and record ...	10
Basic play	
TPS (Tape Program Sensor)	
Before recording	
Recording the radio	
Recording CDs	
Other basic operations	
Radio – Tune	11
Manual tuning	
Memory preset	
FM allocation setting	
Timer	12
Setting the clock	
Using the sleep timer	
Using the play or record timer	
External unit	13
Connecting external unit	
Playing or recording from an external unit	
Sound adjustment	13
Selecting sound effects	
Enjoying surround sound	
Troubleshooting guide	14
Warranty (ONLY FOR U.S.A.)	15
Customer Services Directory (ONLY FOR U.S.A.)	15
Specifications	16
Maintenance	
When moving the unit	

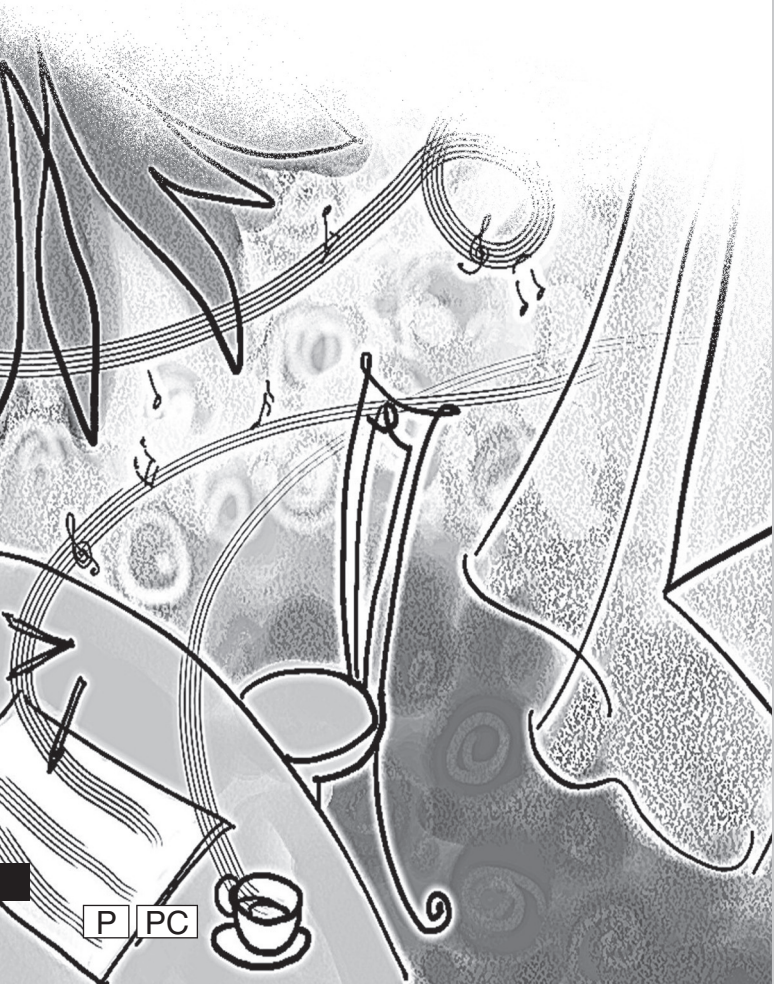

Dear customer

Thank you for purchasing this product.
For optimum performance and safety, please read these instructions carefully.

These operating instructions are applicable to the following system.

System	SC-PM31	SC-PM313
Main unit	SA-PM31	SA-PM313
Speakers	SB-PM31	SB-PM31

The model number and serial number of this product can be found on either the back or the bottom of the unit. Please note them in the space provided below and keep for future reference.

MODEL NUMBER _____
SERIAL NUMBER _____

User memo:

DATE OF PURCHASE _____
DEALER NAME _____
DEALER ADDRESS _____
TELEPHONE NUMBER _____

WARNING:

TO REDUCE THE RISK OF FIRE, ELECTRIC SHOCK OR PRODUCT DAMAGE, DO NOT EXPOSE THIS APPARATUS TO RAIN, MOISTURE, DRIPPING OR SPLASHING AND THAT NO OBJECTS FILLED WITH LIQUIDS, SUCH AS VASES, SHALL BE PLACED ON THE APPARATUS.

CAUTION!

THIS PRODUCT UTILIZES A LASER. USE OF CONTROLS OR ADJUSTMENTS OR PERFORMANCE OF PROCEDURES OTHER THAN THOSE SPECIFIED HEREIN MAY RESULT IN HAZARDOUS RADIATION EXPOSURE. DO NOT OPEN COVERS AND DO NOT REPAIR YOURSELF. REFER SERVICING TO QUALIFIED PERSONNEL.

CAUTION!

DO NOT INSTALL OR PLACE THIS UNIT IN A BOOKCASE, BUILT-IN CABINET OR IN ANOTHER CONFINED SPACE. ENSURE THE UNIT IS WELL VENTILATED. TO PREVENT RISK OF ELECTRIC SHOCK OR FIRE HAZARD DUE TO OVERHEATING, ENSURE THAT CURTAINS AND ANY OTHER MATERIALS DO NOT OBSTRUCT THE VENTILATION VENTS.

Except for U.S.A.

CAUTION	- INVISIBLE LASER RADIATION WHEN OPEN. AVOID EXPOSURE TO BEAM. IEC00205-1 / Class 3b
VARNING	- OSYNLIG LASERSTRÅLNING NÄR DENNA DEL ÄR ÖPPNAD. BETRÄKTA EJ STRÅLEN.
ADVARSEL	- USYNLIG LASERSTRÅLING VED ÅBNING. UNDGÅ UDSÆTTELSE FOR STRÅLING.
ADVARSEL	- USYNLIG LASERSTRÅLING NÄR DEKSEL ÄPNES. UNNGÅ EKSPOSERING FOR STRÅLEN.
VARO!	- AVATTAESSA OLET NÄKYMÄTÖNTÄ ALTTIINA LASERSÄTELYLLE. ÄLÄ KATSO SÄTEESEEN.
VORSICHT	- UNSICHTBARE LASERSTRÄHLUNG, WENN ABDECKUNG GEFÖHNET, NICHT DEM STRAHL AUSSETZEN.
ATTENTION	- RAYONNEMENT LASER INVISIBLE EN CAS D'OUVERTURE. EXPOSITION DANGEREUSE AU FAISCEAU.
注意	- 打开時有不可見激光輻射。避免激光束照射。
注意	- ここを開くと不可視レーザー光が出ます。ビームを見たり、触れたりしないで下さい。 ROLX50058

THE FOLLOWING APPLIES ONLY IN THE U.S.A.

CAUTION:

This equipment has been tested and found to comply with the limits for a Class B digital device, pursuant to Part 15 of the FCC Rules.

These limits are designed to provide reasonable protection against harmful interference in a residential installation. This equipment generates, uses and can radiate radio frequency energy and, if not installed and used in accordance with the instructions, may cause harmful interference to radio communications. However, there is no guarantee that interference will not occur in a particular installation. If this equipment does cause harmful interference to radio or television reception, which can be determined by turning the equipment off and on, the user is encouraged to try to correct the interference by one or more of the following measures:

- Reorient or relocate the receiving antenna.
- Increase the separation between the equipment and receiver.
- Connect the equipment into an outlet on a circuit different from that to which the receiver is connected.
- Consult the dealer or an experienced radio/TV technician for help.

Any unauthorized changes or modifications to this equipment would void the user's authority to operate this device.

This device complies with Part 15 of the FCC Rules. Operation is subject to the following two conditions: (1) This device may not cause harmful interference, and (2) this device must accept any interference received, including interference that may cause undesired operation.

The socket outlet shall be installed near the equipment and easily accessible or the mains plug or an appliance coupler shall remain readily operable.



CAUTION: TO REDUCE THE RISK OF ELECTRIC SHOCK, DO NOT REMOVE SCREWS. NO USER-SERVICEABLE PARTS INSIDE. REFER SERVICING TO QUALIFIED SERVICE PERSONNEL.



The lightning flash with arrowhead symbol, within an equilateral triangle, is intended to alert the user to the presence of uninsulated "dangerous voltage" within the product's enclosure that may be of sufficient magnitude to constitute a risk of electric shock to persons.



The exclamation point within an equilateral triangle is intended to alert the user to the presence of important operating and maintenance (servicing) instructions in the literature accompanying the appliance.

IMPORTANT SAFETY INSTRUCTIONS

Read these operating instructions carefully before using the unit. Follow the safety instructions on the unit and the applicable safety instructions listed below. Keep these operating instructions handy for future reference.

- 1) Read these instructions.
- 2) Keep these instructions.
- 3) Heed all warnings.
- 4) Follow all instructions.
- 5) Do not use this apparatus near water.
- 6) Clean only with dry cloth.
- 7) Do not block any ventilation openings. Install in accordance with the manufacturer's instructions.
- 8) Do not install near any heat sources such as radiators, heat registers, stoves, or other apparatus (including amplifiers) that produce heat.
- 9) Do not defeat the safety purpose of the polarized or grounding-type plug. A polarized plug has two blades with one wider than the other. A grounding-type plug has two blades and a third grounding prong. The wide blade or the third prong are provided for your safety. If the provided plug does not fit into your outlet, consult an electrician for replacement of the obsolete outlet.
- 10) Protect the power cord from being walked on or pinched particularly at plugs, convenience receptacles, and the point where they exit from the apparatus.
- 11) Only use attachments/accessories specified by the manufacturer.
- 12) Use only with the cart, stand, tripod, bracket, or table specified by the manufacturer, or sold with the apparatus. When a cart is used, use caution when moving the cart/apparatus combination to avoid injury from tip-over.
- 13) Unplug this apparatus during lightning storms or when unused for long periods of time.
- 14) Refer all servicing to qualified service personnel. Servicing is required when the apparatus has been damaged in any way, such as power-supply cord or plug is damaged, liquid has been spilled or objects have fallen into the apparatus, the apparatus has been exposed to rain or moisture, does not operate normally, or has been dropped.



Product Service

1. **Damage requiring service**—The unit should be serviced by qualified service personnel if:
 - (a) The AC power supply cord or the plug has been damaged; or
 - (b) Objects or liquids have gotten into the unit; or
 - (c) The unit has been exposed to rain; or
 - (d) The unit does not operate normally or exhibits a marked change in performance; or
 - (e) The unit has been dropped or the cabinet damaged.
2. **Servicing**—Do not attempt to service the unit beyond that described in these operating instructions. Refer all other servicing to authorized servicing personnel.
3. **Replacement parts**—When parts need replacing ensure the servicer uses parts specified by the manufacturer or parts that have the same characteristics as the original parts. Unauthorized substitutes may result in fire, electric shock, or other hazards.
4. **Safety check**—After repairs or service, ask the servicer to perform safety checks to confirm that the unit is in proper working condition.

Product information

For product information or assistance with product operation:
In the U.S.A., refer to "Customer Services Directory" on page 15.
In Canada, contact the Panasonic Canada Inc. Customer Care Centre at 905-624-5505, or visit the website (www.panasonic.ca), or an authorized Servicentre closest to you.

Listening caution



Selecting fine audio equipment such as the unit you've just purchased is only the start of your musical enjoyment. Now it's time to consider how you can maximize the fun and excitement your equipment offers. This manufacturer and the Electronic Industries Association's Consumer Electronics Group want you to get the most out of your equipment by playing it at a safe level. One that lets the sound come through loud and clear without annoying blaring or distortion—and, most importantly, without affecting your sensitive hearing.

We recommend that you avoid prolonged exposure to excessive noise.

Sound can be deceiving. Over time your hearing "comfort level" adapts to higher volumes of sound. So what sounds "normal" can actually be loud and harmful to your hearing.

Guard against this by setting your equipment at a safe level BEFORE your hearing adapts.

To establish a safe level:

- Start your volume control at a low setting.
- Slowly increase the sound until you can hear it comfortably and clearly, and without distortion.

Once you have established a comfortable sound level:

- Set the dial and leave it there.

Taking a minute to do this now will help to prevent hearing damage or loss in the future. After all, we want you listening for a lifetime.

Supplied accessories

Please check and identify the supplied accessories.

Use numbers indicated in parentheses when asking for replacement parts. (As of January 2005)

In U.S.A. to order accessories, refer to "Accessory Purchases" on page 15.

1 x Remote control

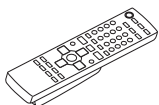

(N2QAJB000132)

1 x FM indoor antenna

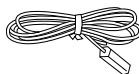

(RSA0007-L)

2 x Remote control batteries



1 x AC power supply cord

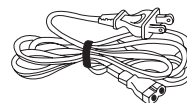

(K2CB2CB00006)

1 x AM loop antenna



(N1DAAAA00001)

Getting started

Step 1 - Making the connections

Connect the AC power supply cord only after all other connections have been made.

Preparation

Twist and pull off the vinyl tip of the speaker cords.

OR

If the speaker cords do not have vinyl tips, directly connect them to the terminals.



1 Connect the AM loop antenna.

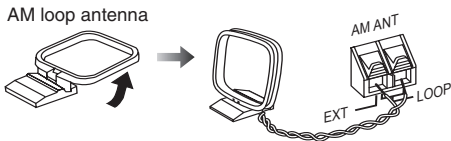

Stand the antenna up on its base. Keep loose antenna cord away from other wires and cords.

2 Connect the FM indoor antenna.

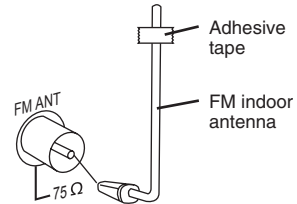

Tape the antenna to a wall or column, in a position with least amount of interference.

3 Connect the speaker cords.

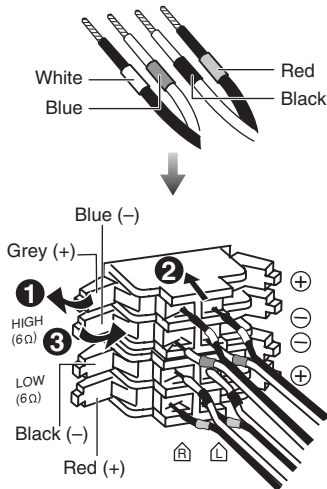

Cords with white and blue tags are for high frequency. Cords with red and black tags are for low frequency. **Incorrect connection can damage the unit.**

4 Connect the AC power supply cord.

- The included AC power supply cord is for use with this unit only. Do not use it with other equipment.

Optional antenna connections

FM outdoor antenna

FM outdoor antenna (not included)

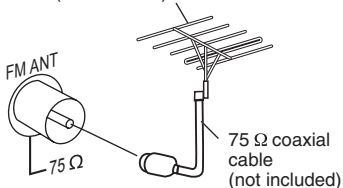

AM outdoor antenna

AM outdoor antenna (not included)

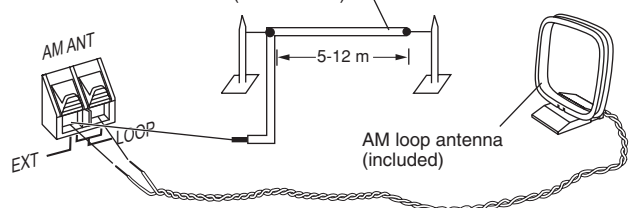

- Never use an outdoor antenna during a lightning storm.
- You can connect the FM outdoor antenna for better reception. Please consult your dealer for installation.
- Disconnect the FM indoor antenna if an FM outdoor antenna is installed.
- Disconnect the AM outdoor antenna without removing the AM loop antenna. Run 5 to 12m of vinyl-covered wire horizontally along a window or other convenient location.

Step 2 - Inserting batteries into the remote control

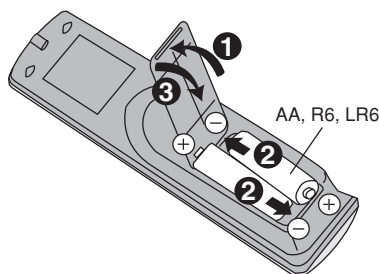

■ Batteries

- Insert so the poles (+ and –) match those in the remote control.
- Remove if the remote control is not going to be used for a long period of time. Store in a cool, dark place.
- Do not use rechargeable type batteries.
- Mishandling of batteries can cause electrolyte leakage which can damage items the fluid contacts and may cause a fire.

Do not:

- mix old and new batteries.
- use different types at the same time.
- heat or expose to flame.
- take apart or short circuit.
- attempt to recharge alkaline or manganese batteries.
- use batteries if the covering has been peeled off.

■ Use

- Aim at the remote control sensor, avoiding obstacles, at a maximum range of 7m (23 feet) directly in front of the unit
Refer to page 6 for the remote control sensor position.

Step 3 - DEMO function



STOP ■, -DEMO

When the unit is first plugged in, a demonstration of its functions may be shown on the display.

If the demo setting is off, you can show a demonstration by selecting “DEMO ON”.

Press and hold [STOP ■, -DEMO].

The display change each time the button is held down.

→ DEMO OFF → DEMO ON →

While in standby mode, select “DEMO OFF” to reduce power consumption.

Placement of speakers

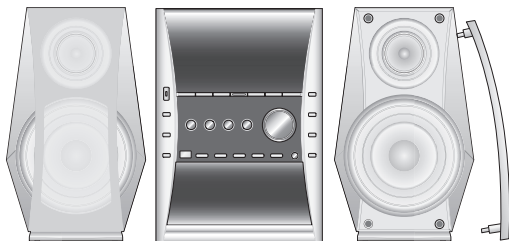

SC-PM31 is used in the illustrations unless otherwise mentioned.

Speakers are designed identically so that no left or right channel orientation is necessary.

- These speakers do not have magnetic shielding. Do not place them near televisions, personal computers or other devices easily influenced by magnetism.
- To avoid damage to the speakers, do not touch the speaker cones if you have taken the nets off.

Note

- Keep your speakers at least 10mm ($\frac{13}{32}$ ”) away from the system for proper ventilation.

Use only the supplied speakers.

- The combination of the main unit and speakers provide the best sound. Using other speakers can damage the unit and sound quality will be negatively affected.

⚠ Caution

- Use the speakers only with the recommended system.
Failure to do so can damage the amplifier and speakers, and can cause fire. Consult a qualified service person if damage occurs or if a sudden change in performance is apparent.
- Do not attach these speakers to walls or ceilings.

Overview of controls

Main unit

Refer numbers in parentheses for page reference.

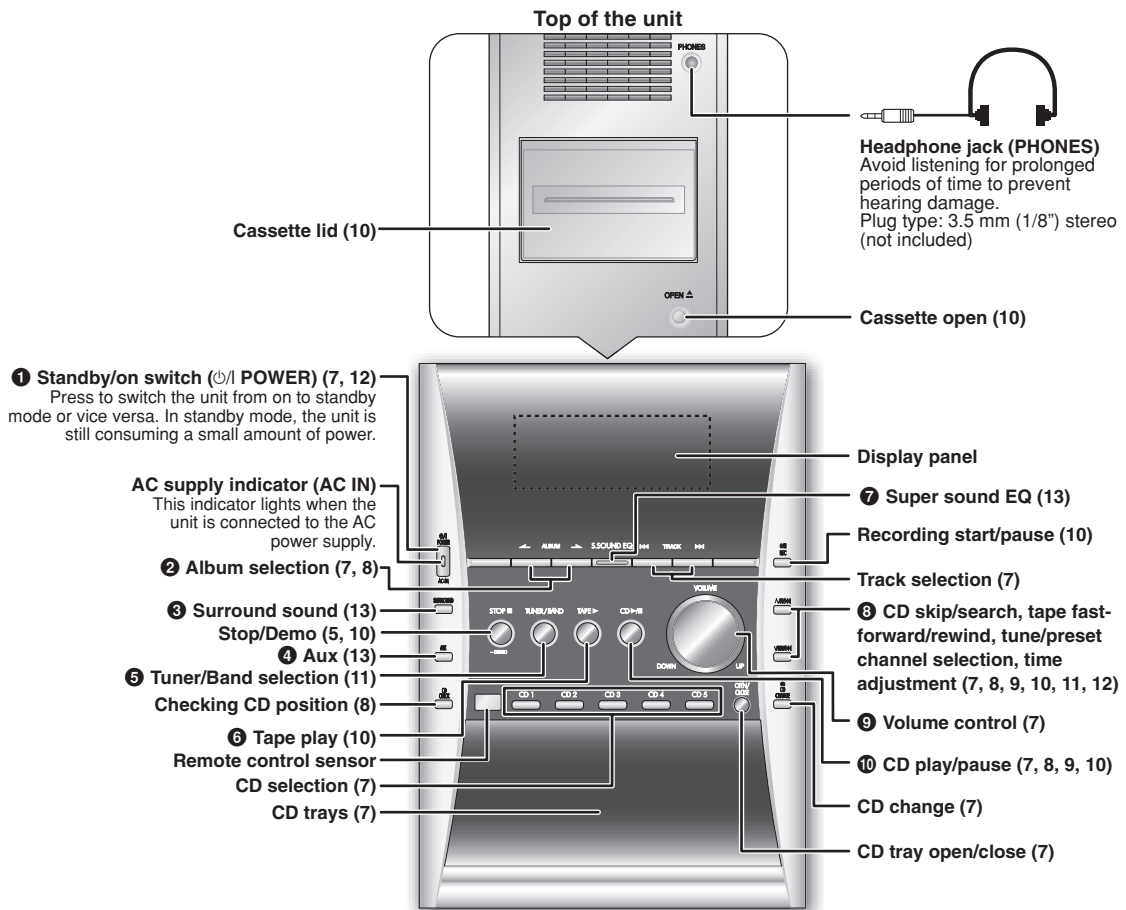

Remote control

Buttons such as 3 function the same as the controls on the main unit.

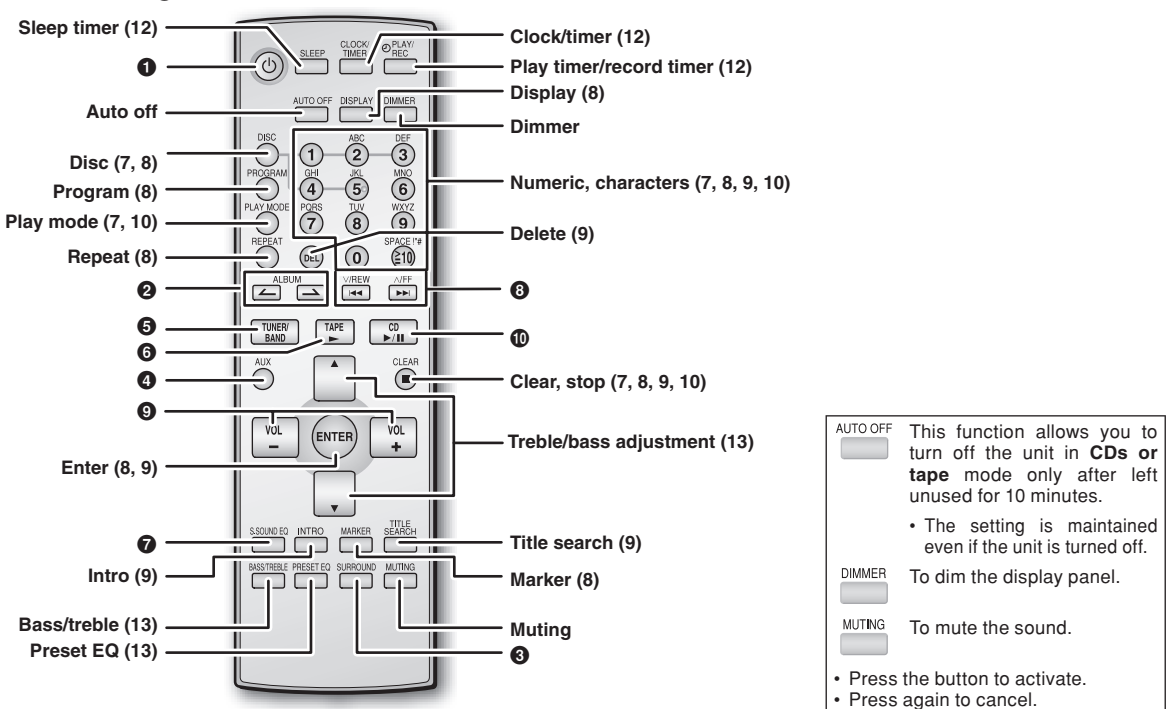

CDs and MP3 – Play

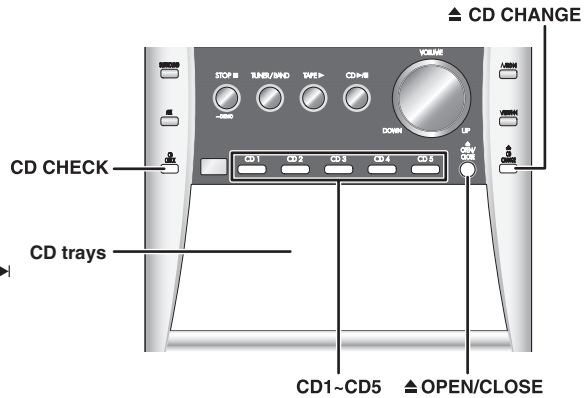
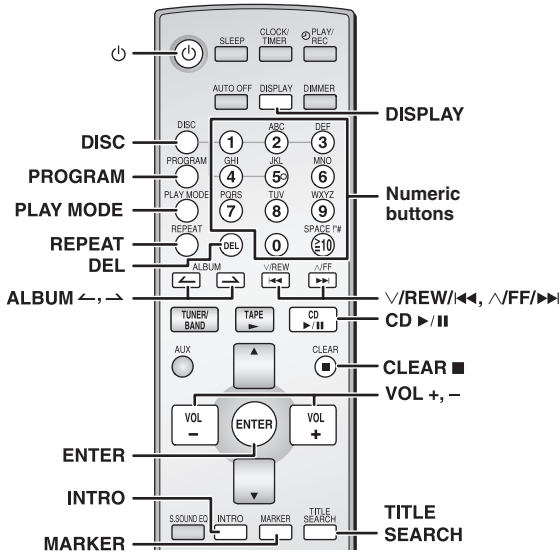

Playing a disc

- 1 Press [POWER] to turn the unit on.
- 2 Press [CD 1 ~ CD 5] to select your desired tray.
- 3 Press [OPEN/CLOSE] to open the disc tray and then load the disc. Press [OPEN/CLOSE] again to close the tray.

Label must face upward

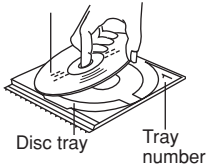

- 4 Press [CD PLAY/PAUSE] to start play.
- 5 Adjust the volume.

Other basic operations

To	Action
stop the disc	Press [CLEAR].
pause play	Press [CD PLAY/PAUSE]. Press again to resume play.
skip tracks	Press [REVERSE] or [SKIP FORWARD].
search through tracks (CD-DA only)	Press and hold [REVERSE] or [SKIP FORWARD] during play or pause.
direct play	If the unit is on standby mode and a CD is loaded, press [CD PLAY/PAUSE] or [CD 1 ~ CD 5] to start play.
skip album (MP3 only)	Press [ALBUM LEFT] or [ALBUM RIGHT] in the play mode. Press [ALBUM LEFT] or [ALBUM RIGHT] once and then the numeric buttons in the stop mode.

Changing disc (CD CHANGE)

While one CD is playing, you can change the CDs in other trays (except in All-Disc random play or program play).

- 1 Press [CD CHANGE].
- 2 Press [CD 1 ~ CD 5] to select the tray.
- 3 Change the CD.
- 4 Press [CD CHANGE] again to close the tray.

Play Mode function

- 1 Press [CD PLAY/PAUSE] and then [CLEAR].
- 2 Press [DISC] and (within 10 seconds) press [1 ~ 5] to select the disc.
- 3 Press [PLAY MODE] to select the desired mode.

Mode	To play
1-DISC 1DISC	one selected disc.
ALL-DISC ALL DISC	all discs in trays, e.g., 4→5→1→2→3.
1-TRACK 1TR	one selected track on the selected disc. Press the numeric buttons to select the track.
1-RANDOM 1DISC RND (CD-DA only)	one selected disc randomly.
A-RANDOM ALL DISC RND (CD-DA only)	all loaded discs randomly.
1-ALBUM 1ALBUM (MP3 only)	one selected album on the selected disc. Press [ALBUM LEFT] or [ALBUM RIGHT] to select the album.
1-DISC RANDOM 1DISC RND (MP3 only)	one selected disc randomly.
1-ALBUM RANDOM 1ALBUM RND (MP3 only)	all tracks in one selected album randomly. Press [ALBUM LEFT] or [ALBUM RIGHT] to select the album.

- During any random play, you cannot skip to tracks which have been played.
- During 1-RANDOM or A-RANDOM play, you can search forward or backward only within the current track.

Checking which CDs are in the trays
(CD CHECK)

CD-DA

MP3

1 Press [CD CHECK].

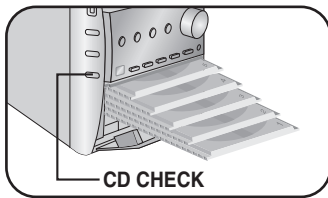

2 Press the button again to close the trays.

- The tray with a CD being played will not open.
- If the player is stopped, all trays will open.
- Do not remove or insert CDs during CD check.
- Do not pull out the trays during CD check.
- 8 cm CDs cannot be checked.

CD display

DISPLAY This function allows you to display the information on the current track.

Press [DISPLAY] repeatedly during play or pause mode.

CD-DA

Remaining play time ↔ Elapsed play time

MP3

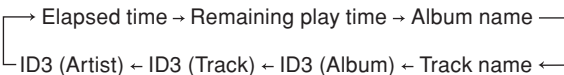

- Maximum number of displayable characters: approximate 30
- This unit supports ver. 1.0 & 1.1 ID3 tags. Text data that is not supported will not be displayed.
- ID3 is a tag embedded in MP3 track to provide information about the track.

Advanced CDs and MP3 functions

Direct access play

This function allows you to start play from a specific track.

CD-DA

Press the numeric buttons to select and play your desired track.

MP3

- 1** Press [ALBUM ← or →] to select the album.
- 2** Press [∧/FF/▶▶] once and then the numeric buttons to select and play your desired track.

For two-digit track, press [≥10] once then the two digits.
For three-digit track, press [≥10] twice then the three digits.
• This function does not work during any random/program mode.

Repeat play

CD-DA

MP3

REPEAT You can repeat program play or other selected play mode.

Press [REPEAT] before or during play.
“REPEAT ON” and “☑” are displayed.

To cancel
Press [REPEAT] again.
“REPEAT OFF” is displayed and “☑” is cleared.

Marking a track

CD-DA

MP3

MARKER Enable you to mark one track for each loaded disc so that you can directly play the track later.

During play, press and hold the [MARKER] until “STORING” blinks on the display to mark your favorite track.

Press [MARKER] during play or stop mode to recall and play a marked track.

- The marker memory is cleared when you open the CD tray.
- This function does not work during any random/program mode.

Program play

PROGRAM This function allows you to program up to 24 tracks.

CD-DA

- 1** Press [CD ▶/II] and then [CLEAR ■].
- 2** Press [PROGRAM].
- 3** Press [DISC].
- 4** (Within 10 seconds or so) Press [1]-[5] to select your desired disc.
- 5** Press the numeric buttons to select your desired track.
Example:

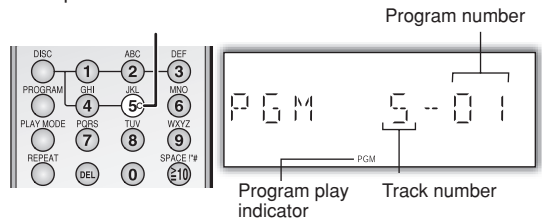

- 6** Repeat steps 3 to 5 to program other tracks.
- 7** Press [CD ▶/II] to start play.

MP3

- 1** Press [CD ▶/II] and then [CLEAR ■].
- 2** Press [DISC].
- 3** (Within 10 seconds or so) Press [1]-[5] to select your desired disc.
- 4** Press [CLEAR ■].
- 5** Press [PROGRAM].
- 6** Press [ALBUM ← or →] to select your desired album.
- 7** Press [∧/FF/▶▶] once and then the numeric buttons to select your desired track.
Example:

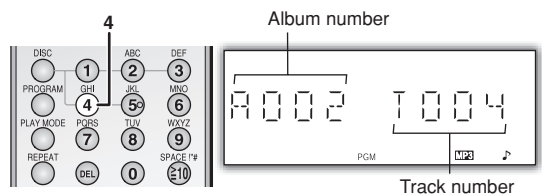

- 8** Press [ENTER].
Repeat steps 6 to 8 to program other tracks.
- 9** Press [CD ▶/II] to start play.

To	Action
cancel program mode	Press [PROGRAM] in the stop mode.
replay the program	Press [PROGRAM] then [CD ▶/II].
check program contents	Press [V/REW/◀◀] or [V/FF/▶▶] when "PGM" is displayed in the stop mode. To check while programming, press [PROGRAM] twice after "PGM" appears, then press [V/REW/◀◀] or [V/FF/▶▶].
add to the program	Repeat steps 3 to 5 in the stop mode for CD-DA (refer page 8). Repeat steps 6 to 8 in the stop mode for MP3 (refer page 8).
clear the last track	Press [DEL] in the stop mode.
clear all programmed tracks	Press [CLEAR ■] in the stop mode. "CLEAR ALL" is displayed. Within 5 seconds, press the button again to clear all tracks.

- When "CD FULL" appears, you cannot program additional tracks.
- During program play for CD-DA, you can search forward or backward only within the current track.
- During program play, skipping is always in the programmed order, whether forward or backward.
- You cannot program CD-DA together with MP3 tracks.
- The program memory is cleared when you change a disc or open a CD tray (**MP3 only**).
- You cannot change or open other trays during program play mode.

INTRO function (Album scan)

MP3

INTRO This function allows you to find an album by listening to the first track of all albums in the current disc for 10 seconds each.

- 1 Press [CD ▶/II] and then [CLEAR ■].
- 2 Press [INTRO] to start the intro function.
- 3 While your desired album is playing, press [CD ▶/II]. Intro mode cancelled and the playback continues.

INTRO function is cancelled after playing the first track in the last album.

To stop during the process, press [INTRO] or [CLEAR ■].

This function does not work during any random/program mode.

Album/Track title search

MP3

TITLE SEARCH Enable you to search your desired album or track.

- 1 Press [CD ▶/II] and then [CLEAR ■].
- 2 For album title search, press [TITLE SEARCH] once. For track title search, press [TITLE SEARCH] twice.
- 3 Press the numeric buttons repeatedly to select your desired character then press [V/FF/▶▶] to key in the next character.
 - You can enter up to 9 characters.
 - To edit, press [V/REW/◀◀] or [V/FF/▶▶] to revise any characters.
 - To delete, move the cursor over the character and then press [DEL].

Numbered buttons	Characters	Numbered buttons	Characters
1	1	6	M N O 6
2	A B C 2	7	P Q R S 7
3	D E F 3	8	T U V 8
4	G H I 4	9	W X Y Z 9
5	J K L 5	0	0
≥10	space !"#%&'()*+,-./:;=?_II		

- 4 Press [ENTER]. Press [V/REW/◀◀] or [V/FF/▶▶] to search for previous or next match.
- 5 Press [CD ▶/II] to start play from the album/track found.

- "NOT FOUND" is displayed when there is no match.
- This function does not work during any random/program mode.

NOTE on CDs

- This unit can access up to 99 tracks.
- Choose CD with this mark.



- This unit can play MP3 files and CD-DA format audio CD-R/RW that have been finalized.
- It may not be able to play some CD-R/RW due to the condition of the recording.
- Do not use irregular shaped disc.
- Do not use disc with labels and stickers that are coming off or with adhesive exuding from under labels and stickers.
- Do not attach extra labels or stickers on the disc.
- Do not write anything on the CD.

Using DualDiscs

The "CD" sides of DualDiscs do not meet the CD-DA standard so it may not be possible to play them on this unit.

Not doing the following will cause damage to the unit.

- "GOOD BYE" is displayed when the unit turns off. Remove the power plug after this display disappears.

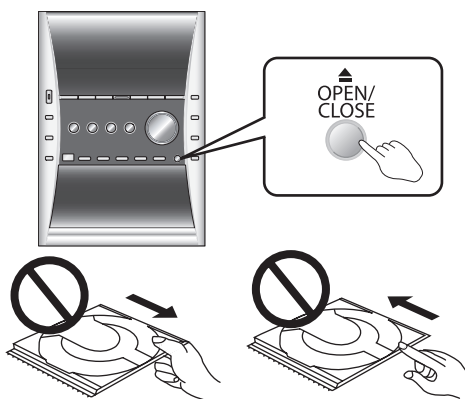

- Always press [▲ OPEN/CLOSE] to insert or remove a disc.
- Do not push or pull out the tray by hand as this will cause an accident.

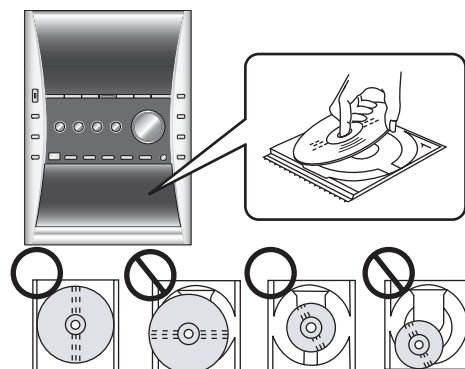

- Place the disc label-up in the center of tray.
- Insert only one disc into each tray.

NOTE on MP3

- When "NOT MP3/ERROR1" appears on the display, an unsupported MP3 format is being played. The unit will skip that track and play the next one.
- Files are treated as tracks and folders are treated as albums.
- This unit can access up to 999 tracks, 255 albums and 20 sessions.
- Disc must conform to ISO9660 level 1 or 2 (except for extended formats).
- To play in a certain order, prefix the folder and file names with 3-digits numbers in the order you want to play them.

MPEG Layer-3 audio decoding technology licensed from Fraunhofer IIS and Thomson multimedia.

Cassette tapes – Play and record

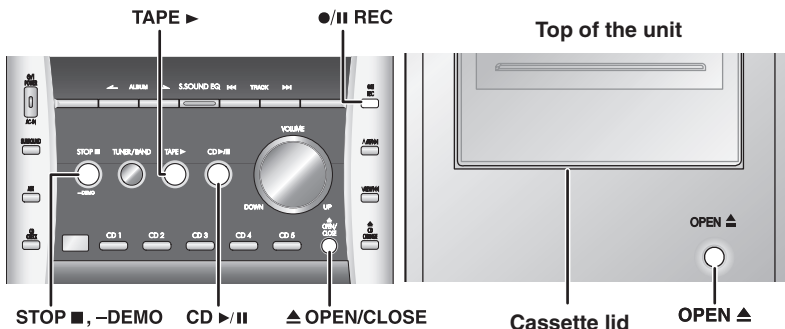
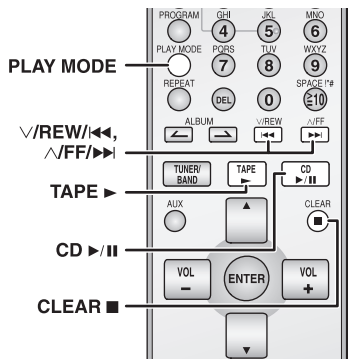

Basic play

- 1 Press [OPEN ▲] on top of the unit.
- 2 Insert a cassette.
 - Forward side
 - Insert inside the guides
- 3 Close the lid by hand.
- 4 Press [TAPE ▶] to start play. To play the other side of the cassette, turn the cassette over.

To	Action
stop tape playback	Press [CLEAR ■].
start one touch play	Press [TAPE ▶] when the system is OFF with the cassette loaded.
fast-forward and rewind	Press [V/REW/◀◀] or [▶▶/FF/Δ] in the stop mode.

TPS (Tape Program Sensor)

This function enables you to search the beginning of a track, up to a maximum of 9.

Press [V/REW/◀◀] or [▶▶/FF/Δ] during play.

Play resumes from the track found.

TPS may not function properly with:

- Short silent parts
- Noise occurs between tunes
- Silent parts found within tunes

Before recording

Preparation:

Wind up the leader tape so that recording can begin immediately.

- Use normal position tapes.
- High position and metal position tapes can be used, but this unit will not be able to record or erase them correctly.

Recording the radio

- 1 Insert the cassette to be recorded on.
- 2 Tune to the required station (refer page 11).
- 3 Press [●/II REC] to start recording.

Recording CDs

- 1 Insert the cassette to be recorded on.
 - Forward side
 - Insert inside the guides
- 2 Press [CD ▶/II] and then [STOP ■, -DEMO].
- 3 Press [▲ OPEN/CLOSE] to insert the CD. Press again to close.
- 4 Press [PLAY MODE] to select your desired mode (refer page 7).
- 5 Press [●/II REC] to start recording.

Recording programmed tracks

- 1 Program the tracks you want (refer page 8).
- 2 Press [●/II REC] to start recording.

Other basic operations

To	Action
erase a recorded sound	1) Insert the cassette to be recorded on. 2) Press [TAPE ▶] and then [CLEAR ■]. 3) Press [●/II REC].
stop recording	Press [CLEAR ■].
stop recording temporarily	1) Press [●/II REC]. 2) Press again to resume recording.
to record on the other side of the tape	Turn the cassette over and press [●/II REC].

Erase prevention

The illustration shows how to remove the tabs to prevent recording. To record on the tape again, cover as shown.

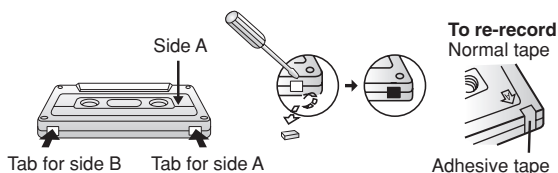

Radio – Tune

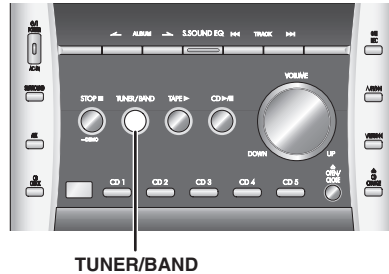
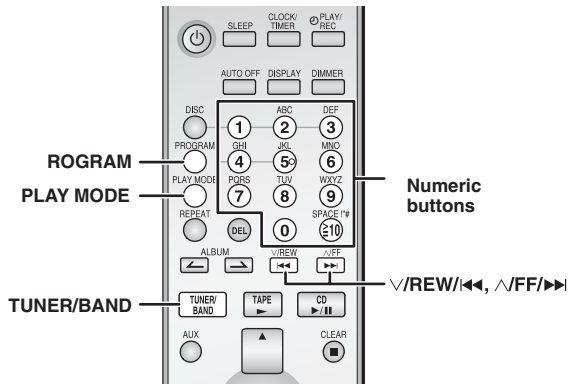

Manual tuning

- 1 Press [TUNER/BAND] to select “FM” or “AM”.
- 2 Press [PLAY MODE] to select “MANUAL”.
- 3 Press [$\sqrt{\text{REW}}/\llcorner$] or [$\lrcorner/\text{FF}/\gg$] to select the frequency of the required station.



- “ST” is displayed when a stereo FM broadcast is being received.

To tune automatically

Press [$\sqrt{\text{REW}}/\llcorner$] or [$\lrcorner/\text{FF}/\gg$] for a moment until the frequency starts changing rapidly. The unit begins auto tuning, stopping when it finds a station.

- Auto tuning may be interrupted when there is excessive interference.
- To cancel auto tuning, press [$\sqrt{\text{REW}}/\llcorner$] or [$\lrcorner/\text{FF}/\gg$] once again.

To improve FM sound quality

Press and hold [PLAY MODE] to display “MONO”.

To cancel

Press and hold [PLAY MODE] again until “MONO” disappear.

- MONO is also cancelled if the frequency is changed.
- Turn off “MONO” for normal listening.

Memory preset

Up to 15 stations each can be set in the FM and AM bands.

Preparation

Press [TUNER/BAND] to select “FM” or “AM”.

Automatic presetting

Press and hold [PROGRAM] to start presetting.

Manual presetting

- 1 Press [PLAY MODE] to select “MANUAL”.
- 2 Press [$\sqrt{\text{REW}}/\llcorner$] or [$\lrcorner/\text{FF}/\gg$] to tune to the required station.
- 3 Press [PROGRAM].
- 4 Press numeric buttons to select a channel.
 - The station occupying a channel is erased if another station is preset in that channel.

Selecting a preset station

Press numeric buttons to select the channel.

- For channels 10 to 15 press [≥ 10], then the two digits.

OR

- 1 Press [PLAY MODE] to select “PRESET”.
- 2 Press [$\sqrt{\text{REW}}/\llcorner$] or [$\lrcorner/\text{FF}/\gg$] to select the channel.

FM allocation setting

By main unit only

- This system can also receive FM broadcasts allocated in 0.1 MHz steps.

To change the step to 0.1 MHz

- 1 Press and hold [TUNER/BAND].
 - After a few seconds the display changes to a flashing display of the current minimum frequency.
- 2 Continue to hold down [TUNER/BAND].
 - When the minimum frequency changes, release the button. To return to the original step, repeat the above steps.
 - After changing the setting, previously preset frequency will be cleared.

Timer

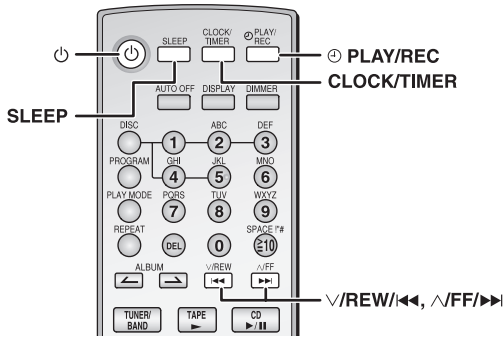

Setting the clock

This is a 12-hour clock.

- 1 Press [CLOCK/TIMER] to select "CLOCK".
Each time you press the button:

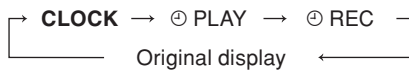

- 2 Within 5 seconds, press [V/REW/◀◀] or [▶▶/FF/▶] to set the time.



- 3 Press [CLOCK/TIMER] again to confirm.



Displaying the clock

Press [CLOCK/TIMER] to display the clock for few seconds.

- The clock may lose or gain some time over a period. Readjust if necessary.

Using the sleep timer

This function enables you to turn off the unit automatically after the set time.

Press [SLEEP] to select your desired time.

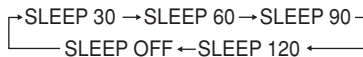

Sleep timer indicator

To cancel

Press [SLEEP] to select "SLEEP OFF".

Changing the remaining time

Press [SLEEP] to show the time and press [SLEEP] again to select your desired time.

- The play and sleep timer or the record and sleep timer can be used together.
- The sleep timer always has priority. Be sure not to overlap timer settings.

Using the play or record timer

You can set the timer to come on at a certain time to wake you up (play timer) or to record from the radio or an aux source (record timer).

Turn the unit on and set the clock.

Timer	Action
Play timer	Prepare the music source you want to listen to; tape, CD number (1~5), radio or AUX, and set the volume.
Record timer	Check the cassette's erasure prevention tabs (refer page 10), insert the cassette and tune to the radio station (refer page 11) or select the aux source (refer page 13).

- 1 Press [CLOCK/TIMER] to select your desired timer.
Each time you press the button:



- 2 Within 5 seconds, press [V/REW/◀◀] or [▶▶/FF/▶] to set the starting time.

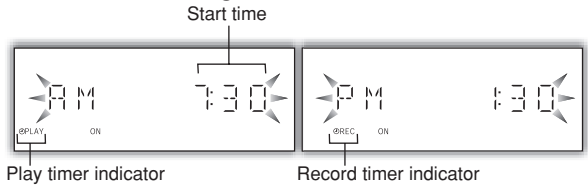

- 3 Press [CLOCK/TIMER] to confirm.

- 4 Repeat steps 2 to 3 to set the finishing time.

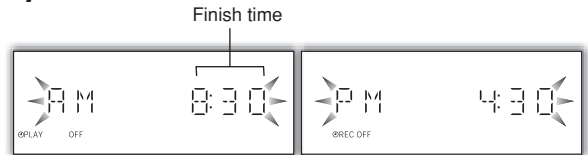

To activate the timer

- 5 Press [◻PLAY/REC] to turn on your desired timer.



- 6 Press [⏻] to turn off the unit.

The unit must be off for the timers to operate.

To enjoy the desired source after the timer setting is completed.

The volume level (for play timer) and music source are stored in the timer memory and the timer will start in these preset conditions. However, the CD numbers do not get stored in the timer memory.

1. After step 5, start playing the desired source.
2. Reset the CD numbers if you have changed any of them, confirm that a CD or cassette is inserted, then press [⏻] to put the unit on standby.

Other basic operations

To	Action
change the settings	Repeat steps 1 to 4 and 6 above.
change the source or volume	1) Press [◻PLAY/REC] to clear the timer indicator from the display. 2) Make changes to the source or volume. 3) Do steps 5 to 6 as above.
check the settings (when the unit is on or in standby mode)	Press [CLOCK/TIMER] repeatedly to select ◻PLAY or ◻REC.
cancel	Press [◻PLAY/REC] to clear the timer indicators from the display.

- Play timer and record timer cannot be used together.
- The play timer will start at the preset time with volume increasing gradually to preset level.
- The record timer will start 30 seconds before the set time with the volume muted.
- The timer comes on at the set time everyday if the timer is on.
- The unit must be in the standby mode for the timer to function.
- If you turn the unit off and on again while a timer is functioning, the finish time setting will not be activated.
- If AUX is selected as the source, when the timer comes on, the system turns on and engages AUX as the source. If you want to playback or record from a connected unit, set the other unit's timer to the same time. (See the other unit's instruction manual.)

External unit



Connecting external unit

Preparation:

- Make sure that the power supply for all components has been turned off before making any connections.
- For details, refer to the operating instructions of the unit which is to be connected.
- All peripheral components and cables sold separately.

Connecting analog equipment

This example shows how to connect an analog player with a PHONO OUT/LINE OUT switch.

When units other than those described are to be connected, please consult your dealer.

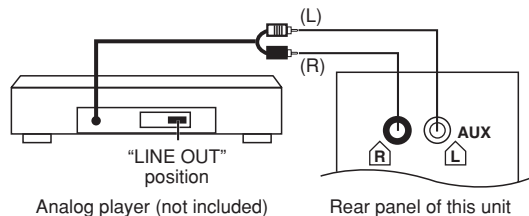

- An analog player with a built-in phono equalizer can be connected.
- Set the switch to the "LINE OUT" position at the back of the analog player.

Playing or recording from an external unit

- 1 Press [AUX].
- 2 For listening: Proceed to step 3.
For recording: Press [●/|| REC] to start recording.
- 3 Start playback from the external source. (For details, refer to the external unit's instruction manual.)

Sound adjustment

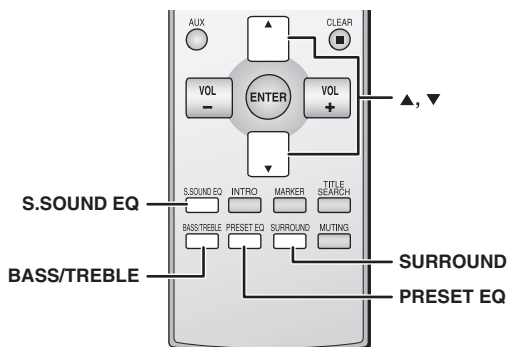

Selecting sound effects

You can change the sound effect by selecting Super Sound EQ, Preset EQ or adjusting the bass or treble effect.

Super sound EQ

Provide you with clearer bass and treble effects.

To activate

Press [S.SOUND EQ] to display "S.SOUND EQ" indicator.

To cancel

Press [S.SOUND EQ] again to clear "S.SOUND EQ" indicator.

Preset EQ

Press [PRESET EQ] repeatedly to select your desired setting.

HEAVY → CLEAR → SOFT → VOCAL → EQ-OFF

Setting	Effect
HEAVY	Adds punch to rock
CLEAR	Clarifies higher frequencies
SOFT	For background music
VOCAL	Adds gloss to vocal
EQ-OFF	No effect

Bass or treble

Enable you to enjoy the lower or higher pitch sound.

- 1 Press [BASS/TREBLE] repeatedly to select your desired setting.

Setting	Effect
BASS	For lower pitch sound
TREBLE	For higher pitch sound

- 2 Press [▼] or [▲] to adjust the level.
The tone level can be varied within -3 to +3.

Enjoying surround sound

Enable you to add natural width and depth to the stereo sound.

To activate

Press [SURROUND] to display "■ ■ ■ ■ ■ ■ ■ ■" indicator.

To cancel

Press [SURROUND] again to clear "■ ■ ■ ■ ■ ■ ■ ■" indicator.

- Surround sound is less discernible when listening through headphones.
- If interference in FM stereo reception increases, cancel the surround sound effect.

Troubleshooting guide

Before requesting service, make the following checks. If you are in doubt about some of the check points, or if the remedies indicated in the chart do not solve the problem, refer to the "Customer Services Directory" on page 15 if you reside in the U.S.A., or refer to the "Product information" on page 3 if you reside in Canada.

Common problems

No sound.	Turn the volume up. The speaker cords may not be connected properly. Turn the unit off, check and correct the connections and turn the unit on (refer page 4).
Sound is unfixed, reversed or comes from one speaker only.	Check the speaker connections (refer page 4).
Humming heard during play.	An AC power supply cord or fluorescent light is near the cables. Keep other appliances and cords away from this unit's cables.
"ERROR" is displayed.	Incorrect operation performed. Read the instructions and try again.
"--:--" appears on the display.	You plugged the AC power supply cord in for the first time or there was a power failure recently. Set the time (refer page 12).
"F61" is displayed.	Check and correct the speaker cord connections (refer page 4). If this does not fix the problem, there is a power supply problem. Consult the dealer.

Listening to the radio

Noise is heard. The stereo indicator flickers or doesn't light. Sound is distorted.	Use an outdoor antenna (refer page 4).
A beat sound is heard.	Turn the TV off or separate it from the unit.
A low hum is heard during AM broadcast.	Separate the antenna from other cables and cords.

When there is a television set nearby

The picture on the TV disappears or stripes appear on the screen.	The location and orientation of the antenna are incorrect. If you are using an indoor antenna, change to an outdoor antenna (refer page 4). The TV antenna wire is too close to the unit. Separate the antenna wire of the TV set from the unit.
--	---

Using the cassette deck

Recording is not possible.	If the erasure prevention tabs have been removed, cover the holes with adhesive tape (refer page 10).
-----------------------------------	---

Playing discs

The display is wrong or play won't start.	The disc may be upside down (refer page 7). Wipe the disc. Replace the disc if it is scratched, warped, or non-standard. Condensation may have formed inside the unit due to a sudden change in temperature. Wait about an hour for it to clear and try again.
The total number of tracks displayed differs each time the same disc is inserted. Unusual sound is heard.	The disc may be scratched, or its data may be defective. Replace the disc.
CD-RW cannot be read.	The disc was incompletely formatted. Use the recording equipment to fully format the disc before recording.
"VBR-" is displayed instead of the remaining play time.	The unit cannot display the remaining play time for variable bit rate (VBR) tracks.
"TAKE OUT/DISC" appears on the display.	There is a problem with the disc mechanism. (A power failure may have occurred.) The tray will open automatically. Remove the disc from the tray, and after ensuring there is no disc in the tray, close it. The unit will make the disc changing noises for a few moments and then it should operate normally.

The remote control

Remote control doesn't work.	Check that the batteries are inserted correctly (refer page 5). Replace the batteries if they are worn.
-------------------------------------	--

Warranty (ONLY FOR U.S.A.)

Panasonic Consumer Electronics Company,
Division of Panasonic Corporation of North America
One Panasonic Way Secaucus, New Jersey 07094

Panasonic Puerto Rico, Inc.
Ave. 65 de Infantería, Km. 9.5
San Gabriel Industrial Park, Carolina, Puerto Rico 00985

Panasonic Audio Products Limited Warranty

Limited Warranty Coverage

If your product does not work properly because of a defect in materials or workmanship, Panasonic Consumer Electronics Company or Panasonic Puerto Rico, Inc. (collectively referred to as "the warrantor") will, for the length of the period indicated on the chart below, which starts with the date of original purchase ("warranty period"), at its option either (a) repair your product with new or refurbished parts, or (b) replace it with a new or a refurbished product. The decision to repair or replace will be made by the warrantor.

Product or Part Name	Parts	Labor
Audio Products (except items listed below)	One (1) year	One (1) year
USB Reader-Writer, Personal Computer Card Adapters (in exchange for defective item)	One (1) year	Not Applicable
Accessories: Headphones, Cartridges, Microphones, Adapters	Ninety (90) days	Ninety (90) days
Rechargeable Batteries, DVD-R/-RAM Discs (in exchange for defective item)	Ten (10) days	Not Applicable
SD Memory Cards, Rechargeable Battery Packs (in exchange for defective item)	Ninety (90) days	Not Applicable

During the "Labor" warranty period there will be no charge for labor. During the "Parts" warranty period, there will be no charge for parts. You must carry-in or mail-in your product during the warranty period. If non-rechargeable batteries are included, they are not warranted. This warranty only applies to products purchased and serviced in the United States or Puerto Rico. This warranty is extended only to the original purchaser of a new product which was not sold "as is". A purchase receipt or other proof of the original purchase date is required for warranty service.

Carry-In or Mail-In Service

For Carry-In or Mail-In Service in the United States call 1-800-211-PANA (1-800-211-7262) or visit Panasonic web site: <http://www.panasonic.com>
For assistance in Puerto Rico call Panasonic Puerto Rico, Inc. (787)-750-4300 or fax (787)-768-2910.

Limited Warranty Limits And Exclusions

This warranty ONLY COVERS failures due to defects in materials or workmanship, and DOES NOT COVER normal wear and tear or cosmetic damage. The warranty ALSO DOES NOT COVER damages which occurred in shipment, or failures which are caused by products not supplied by the warrantor, or failures which result from accidents, misuse, abuse, neglect, mishandling, misapplication, alteration, faulty installation, set-up adjustments, misadjustment of consumer controls, improper maintenance, power line surge, lightning damage, modification, or commercial use (such as in a hotel, office, restaurant, or other business), rental use of the product, service by anyone other than a Factory Servicenter or other Authorized Servicer, or damage that is attributable to acts of God.

THERE ARE NO EXPRESS WARRANTIES EXCEPT AS LISTED UNDER "LIMITED WARRANTY COVERAGE". THE WARRANTOR IS NOT LIABLE FOR INCIDENTAL OR CONSEQUENTIAL DAMAGES RESULTING FROM THE USE OF THIS PRODUCT, OR ARISING OUT OF ANY BREACH OF THIS WARRANTY. (As examples, this excludes damages for lost time, travel to and from the servicer, loss of media or images, data or other memory content. The items listed are not exclusive, but are for illustration only.) **ALL EXPRESS AND IMPLIED WARRANTIES, INCLUDING THE WARRANTY OF MERCHANTABILITY, ARE LIMITED TO THE PERIOD OF THE LIMITED WARRANTY.**

Some states do not allow the exclusion or limitation of incidental or consequential damages, or limitations on how long an implied warranty lasts, so the exclusions may not apply to you.

This warranty gives you specific legal rights and you may also have other rights which vary from state to state. If a problem with this product develops during or after the warranty period, you may contact your dealer or Servicenter. If the problem is not handled to your satisfaction, then write to the warrantor's Consumer Affairs Department at the addresses listed for the warrantor.

PARTS AND SERVICE WHICH ARE NOT COVERED BY THIS LIMITED WARRANTY ARE YOUR RESPONSIBILITY.

Customer Services Directory (ONLY FOR U.S.A.)

Obtain Product Information and Operating Assistance; locate your nearest Dealer or Servicenter; purchase Parts and Accessories; or make Customer Service and Literature requests by visiting our Web Site at:

<http://www.panasonic.com/consumersupport>

or, contact us via the web at:

<http://www.panasonic.com/contactinfo>

You may also contact us directly at:

1-800-211-PANA (7262),

Monday-Friday 9 am-9 pm; Saturday-Sunday 10 am-7 pm, EST.

For hearing or speech impaired TTY users, TTY: 1-877-833-8855

Accessory Purchases

Purchase Parts, Accessories and Instruction Books online for all Panasonic Products by visiting our Web Site at:

<http://www.pasc.panasonic.com>

or, send your request by E-mail to:

npcparts@us.panasonic.com

You may also contact us directly at:

1-800-332-5368 (Phone) 1-800-237-9080 (Fax Only) (Monday-Friday 9 am to 8 pm, EST.)

Panasonic Services Company

20421 84th Avenue South, Kent, WA 98032

(We Accept Visa, MasterCard, Discover Card, American Express, and Personal Checks)

For hearing or speech impaired TTY users, TTY: 1-866-605-1277

Service in Puerto Rico

Panasonic Puerto Rico, Inc.

Ave. 65 de Infantería, Km. 9.5, San Gabriel Industrial Park, Carolina, Puerto Rico 00985

Phone (787)750-4300, Fax (787)768-2910

Specifications

AMPLIFIER SECTION

FTC Output Power both channel driven

10% total harmonic distortion

60 Hz–3 kHz

(Low channel)

SC-PM31 35 W per channel (6 Ω)

SC-PM313 30 W per channel (6 Ω)

3 kHz–16 kHz

(High channel)

SC-PM31 35 W per channel (6 Ω)

SC-PM313 30 W per channel (6 Ω)

Total Bi-Amp power

SC-PM31 70 W per channel

SC-PM313 60 W per channel

RMS Output Power both channel driven

10% total harmonic distortion

1 kHz

(Low channel)

SC-PM31 40 W per channel (6 Ω)

SC-PM313 35 W per channel (6 Ω)

8 kHz

(High channel)

SC-PM31 40 W per channel (6 Ω)

SC-PM313 35 W per channel (6 Ω)

Total Bi-Amp power

SC-PM31 80 W per channel

SC-PM313 70 W per channel

Output Impedance

Headphone

16 Ω – 32 Ω

FM TUNER SECTION

Frequency range

87.5 MHz – 108.0 MHz (100 kHz steps)

87.9 MHz – 107.9 MHz (200 kHz steps)

Sensitivity

S/N 26 dB

1.02 μV (IHF)

1.00 μV

Antenna terminal(s)

75 Ω (unbalanced)

AM TUNER SECTION

Frequency range

520 kHz – 1710 kHz (10 kHz steps)

Sensitivity

S/N 20 dB (at 1000 kHz)

900 μV/m

CASSETTE DECK SECTION

Track system

4 track, 2 channel

Heads

Record/playback

Solid permalloy head

Erasure

Double gap ferrite head

Motor

DC servo motor

Recording system

AC bias 100 kHz

Erasing system

AC erase 100 kHz

Tape speed

4.8 cm/s

Overall frequency response (+3 dB, -6 dB) at DECK OUT

NORMAL

35 Hz – 14 kHz

S/N RATIO

42.64 dB (A weighted)

Wow and flutter

0.08% (WRMS)

Fast forward and rewind time

Approx. 120 seconds with C-60 cassette tape

CD SECTION

Disc

CD, CD-R, CD-RW, MP3

8 cm/12 cm (3³/₂₀"/4⁷³/₁₀₀"

Sampling frequency

44.1 kHz

Decoding

16/20/24 bit linear

Beam source/wavelength

Semiconductor laser/780 nm

Number of channels

Stereo

Frequency response

20 Hz – 20 kHz (+1 dB, -2 dB)

Wow and flutter

Below measurable limit

Digital filter

8 fs

D/A converter

MASH (1 bit DAC)

MP3

Bit rate

32 kbps – 320 kbps

Sampling frequency

32 kHz, 44.1 kHz, 48 kHz

SPEAKER SECTION

Type

2 way, 2 speaker system

Speaker(s)

Woofers

10 cm (4") cone type

Tweeters

6 cm (2³/₈") cone type

Impedance

6 Ω

Input power (IEC)

HIGH

80 W (Max)

LOW

80 W (Max)

Output sound pressure level

SC-PM31 79 dB/W (1.0 m)

SC-PM313 81 dB/W (1.0 m)

Frequency range

SC-PM31 45 Hz – 26 kHz (-16 dB)

50 Hz – 25 kHz (-10 dB)

SC-PM313 55 Hz – 22 kHz (-16 dB)

75 Hz – 20 kHz (-10 dB)

Dimensions (WxHxD)

SC-PM31 153 mm x 254 mm x 239 mm

(6¹/₃₂" x 10" x 9¹³/₃₂"

SC-PM313 145 mm x 254 mm x 217 mm

(5²³/₃₂" x 10" x 8¹⁹/₃₂"

Mass

SC-PM31 1.83 kg (4.03 lbs.)

SC-PM313 2.00 kg (4.41 lbs.)

GENERAL

Power supply

AC 120 V, 60 Hz

Power consumption

135 W

Dimensions (WxHxD)

175 mm x 254 mm x 391 mm

(6⁷/₈" x 10" x 15³/₈"

Mass

5.44 kg (11.99 lbs.)

Power consumption in standby mode: 0.4 W

Notes:

- Specifications are subject to change without notice. Mass and dimensions are approximate.
- Total harmonic distortion is measured by the digital spectrum analyzer.
- The labels "HIGH" and "LOW" on the rear of the speakers refer to High frequency and Low frequency.

Maintenance

If the surfaces are dirty

To clean this unit, wipe with a soft, dry cloth.

- Never use alcohol, paint thinner or benzene to clean this unit.
- Before using chemically treated cloth, read the instructions that came with the cloth carefully.

For a cleaner crisper sound

Clean the heads regularly to assure good quality playback and recording.

Use a cleaning tape (not included).

When moving the unit

- Remove all discs.
- Press [⏻/I POWER] to turn the unit off.
- Disconnect the AC power supply cord.

Panasonic Consumer Electronics
Company, Division of Panasonic
Corporation of North America
One Panasonic Way Secaucus,
New Jersey 07094
<http://www.panasonic.com>

Panasonic Puerto Rico, Inc.
Ave. 65 de Infantería, Km. 9.5
San Gabriel Industrial Park, Carolina,
Puerto Rico 00985

Panasonic Canada Inc.
5770 Ambler Drive
Mississauga, Ontario,
L4W 2T3
www.panasonic.ca

En