



## Operating Instructions DVD Home Theater Sound System

Model No. **SC-HT441W**

### Region number

The player plays DVD-Video marked with labels containing the region number "1" or "ALL".

Example:



## Wireless system and digital transceiver

Wireless surround speaker  
connection.

page **6**

## Advanced progressive scan

Provides a smoother  
and sharper image.

page **8**

## XM® Satellite Radio

Enjoy music, news, sports,  
talk and more.

page **28**

Before connecting, operating or adjusting this product,  
please read the instructions completely.  
Please keep this manual for future reference.

If you have any questions contact  
**1-800-211-PANA (7262)**

# Dear customer

Thank you for purchasing this product. For optimum performance and safety, please read these instructions carefully.

Operations in these instructions are described mainly with the remote control, but you can perform the operations on the main unit if the controls are the same.

System	SC-HT441W
Main unit	SA-HT441
Front speakers	SB-FS440
Center speaker	SB-PC640
Surround speakers	SB-FS441
Subwoofer	SB-W440
Wireless system	SE-FX60
Digital transceiver	SH-FX60T

## CAUTION!

THIS PRODUCT UTILIZES A LASER. USE OF CONTROLS OR ADJUSTMENTS OR PERFORMANCE OF PROCEDURES OTHER THAN THOSE SPECIFIED HEREIN MAY RESULT IN HAZARDOUS RADIATION EXPOSURE. DO NOT OPEN COVERS AND DO NOT REPAIR YOURSELF. REFER SERVICING TO QUALIFIED PERSONNEL.

## WARNING:

TO REDUCE THE RISK OF FIRE, ELECTRIC SHOCK OR PRODUCT DAMAGE, DO NOT EXPOSE THIS APPARATUS TO RAIN, MOISTURE, DRIPPING OR SPLASHING AND THAT NO OBJECTS FILLED WITH LIQUIDS, SUCH AS VASES, SHALL BE PLACED ON THE APPARATUS.

## CAUTION!

DO NOT INSTALL OR PLACE THIS UNIT IN A BOOKCASE, BUILT-IN CABINET OR IN ANOTHER CONFINED SPACE. ENSURE THE UNIT IS WELL VENTILATED. TO PREVENT RISK OF ELECTRIC SHOCK OR FIRE HAZARD DUE TO OVERHEATING, ENSURE THAT CURTAINS AND ANY OTHER MATERIALS DO NOT OBSTRUCT THE VENTILATION VENTS.



## CAUTION

RISK OF ELECTRIC SHOCK  
DO NOT OPEN



CAUTION: TO REDUCE THE RISK OF ELECTRIC SHOCK, DO NOT REMOVE SCREWS. NO USER-SERVICEABLE PARTS INSIDE. REFER SERVICING TO QUALIFIED SERVICE PERSONNEL.



The lightning flash with arrowhead symbol, within an equilateral triangle, is intended to alert the user to the presence of uninsulated "dangerous voltage" within the product's enclosure that may be of sufficient magnitude to constitute a risk of electric shock to persons.



The exclamation point within an equilateral triangle is intended to alert the user to the presence of important operating and maintenance (servicing) instructions in the literature accompanying the appliance.

The socket outlet shall be installed near the equipment and easily accessible. The mains plug of the power supply cord shall remain readily operable.

To completely disconnect this apparatus from the AC Mains, disconnect the power supply cord plug from AC receptacle.

# IMPORTANT SAFETY INSTRUCTIONS

Read these operating instructions carefully before using the unit. Follow the safety instructions on the unit and the applicable safety instructions listed below. Keep these operating instructions handy for future reference.

- 1) Read these instructions.
- 2) Keep these instructions.
- 3) Heed all warnings.
- 4) Follow all instructions.
- 5) Do not use this apparatus near water.
- 6) Clean only with dry cloth.
- 7) Do not block any ventilation openings. Install in accordance with the manufacturer's instructions.
- 8) Do not install near any heat sources such as radiators, heat registers, stoves, or other apparatus (including amplifiers) that produce heat.
- 9) Do not defeat the safety purpose of the polarized or grounding-type plug. A polarized plug has two blades with one wider than the other. A grounding-type plug has two blades and a third grounding prong. The wide blade or the third prong are provided for your safety. If the provided plug does not fit into your outlet, consult an electrician for replacement of the obsolete outlet.
- 10) Protect the power cord from being walked on or pinched particularly at plugs, convenience receptacles, and the point where they exit from the apparatus.
- 11) Only use attachments/accessories specified by the manufacturer.
- 12) Use only with the cart, stand, tripod, bracket, or table specified by the manufacturer, or sold with the apparatus. When a cart is used, use caution when moving the cart/apparatus combination to avoid injury from tip-over.
- 13) Unplug this apparatus during lightning storms or when unused for long periods of time.
- 14) Refer all servicing to qualified service personnel. Servicing is required when the apparatus has been damaged in any way, such as power-supply cord or plug is damaged, liquid has been spilled or objects have fallen into the apparatus, the apparatus has been exposed to rain or moisture, does not operate normally, or has been dropped.



# TABLE OF CONTENTS

## Getting Started



**IMPORTANT SAFETY INSTRUCTIONS** ..... 2

### Simple Setup

**STEP 1** Positioning the speakers ..... 4  
 Speaker installation options ..... 5

**STEP 2** Speaker connections ..... 6  
 Connecting the surround speaker cables to the wireless system ..... 6

**STEP 3** Radio and digital transceiver connections ..... 7  
 Connecting the digital transceiver ..... 7

**STEP 4** Audio and video connections ..... 8  
 Basic audio connection ..... 8  
 Basic video connection ..... 8

**STEP 5** AC cord connections ..... 9

**STEP 6** Preparing the remote control ..... 10

**STEP 7** Performing QUICK SETUP ..... 10

Control reference guide ..... 11

Discs that can be played ..... 12

Disc caution ..... 12

Maintenance ..... 12

Product Service ..... 13

Glossary ..... 13



## Playing Discs



**Basic play** ..... 14  
 Using the main unit ..... 14  
 Using the remote control ..... 15

**Convenient functions** ..... 16  
 Checking the disc type in each tray ..... 16  
 Displaying current playback condition ..... 16  
 Playing CDs sequentially ..... 16  
 Program and Random play ..... 17

**Playing data discs using navigation menus** ..... 18  
 Playing data discs ..... 18  
 Selecting a track using CD text ..... 18  
 Playing HighMAT™ discs ..... 19  
 Playing RAM discs ..... 19

**Using on-screen menus** ..... 20  
 Main menu ..... 20  
 Other Settings ..... 21

**Changing the player settings** ..... 23  
 Changing the delay time of the speakers ..... 25



## Other Operations



**Using the AM/FM Radio** ..... 26  
 Presetting stations automatically ..... 26  
 Selecting the preset channels ..... 26  
 Manual tuning ..... 26  
 Using an outdoor antenna (optional) ..... 27

**Using the XM® Satellite Radio** ..... 28  
 Displaying the XM Satellite Radio ID ..... 28  
 Positioning the XM Connect & Play or XMPassport system for optimal reception ..... 28  
 Selecting XM channels by direct entry ..... 29  
 Selecting XM channels by category ..... 29  
 Presetting your favorite XM channels ..... 29  
 Displaying the XM channel information ..... 29

**Using sound effects** ..... 30  
 Changing the sound quality: Sound Field Control ..... 30  
 Enhancing the sound from the center speaker: Center Focus ..... 30  
 Enhancing the stereo sound: Dolby Pro Logic II ..... 30  
 Adjusting the amount of bass: Subwoofer level ..... 30  
 Adjusting the volume of each speaker: Speaker level adjustments ..... 31

**Operating other equipment** ..... 31  
 Operating the television ..... 31

**Using other useful functions** ..... 32  
 Setting the sleep timer ..... 32  
 Muting the sound ..... 32  
 Using headphones ..... 32  
 Using the Music Port ..... 32



## Reference



**Troubleshooting guide** ..... 33

**Specifications** ..... 36

**Limited Warranty** ..... 38

**Accessories** ..... Back cover



# STEP 1 Positioning the speakers

How you set up your speakers can affect the bass and the sound field. Note the following points:

- Place speakers on flat secure bases.
- Placing speakers too close to floors, walls, and corners can result in excessive bass. Cover walls and windows with thick curtains.
- Left and right speakers are interchangeable, but front and surround speakers are not.

## Setup example

Place the front, center, and surround speakers at approximately the same distance from the seating position. The angles in the diagram are approximate.

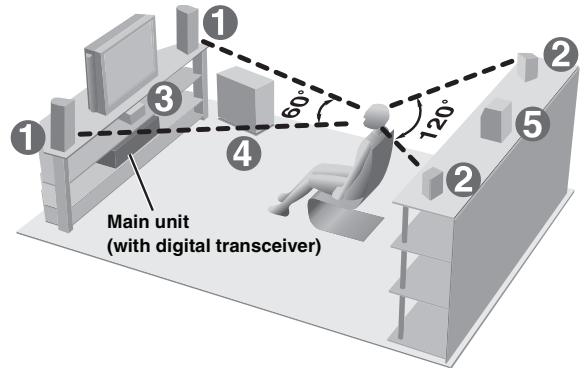
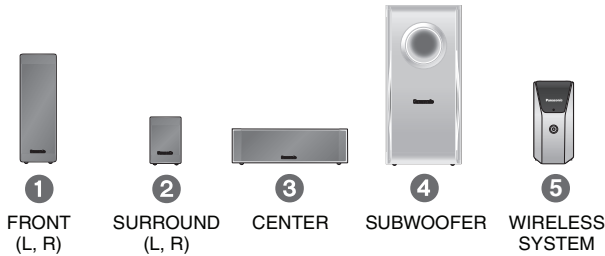

## Use only supplied speakers

- Using other speakers can damage the unit, and sound quality will be negatively affected.
- Set the speakers up on an even surface to prevent them from falling. Take proper precautions to prevent the speakers from falling if you cannot set them up on an even surface.

## Main unit

### Note

- Keep your speakers at least 10 mm ( $13/32$ " ) away from the system for proper ventilation.
- To allow for proper ventilation and to maintain good airflow around the main unit, position it with at least 5 cm (2") of space on all sides.
- Do not block the ventilation holes of the main unit.

## Center speaker

- Vibration caused by the center speaker can disrupt the picture if it is placed directly on the television. Put the center speaker on a rack or shelf.
- To prevent the speakers from falling, do not place directly on top of the television.

## Wireless system

- Place the wireless system within approximately 10 m (33 ft) from the main unit.
- Do not use the wireless system or the digital transceiver in a metal cabinet or bookshelf.

## Subwoofer

Place to the right or left of the television, on the floor or a sturdy shelf so that it will not cause vibration. Leave about 30 cm ( $11^{13/16}$ " ) from the television.

## Caution

Do not touch the netted area of the speakers.

e.g. Surround speaker



## Notes on speaker use

- You can damage your speakers and shorten their useful life if you play sound at high levels over extended periods.
- Reduce the volume in the following cases to avoid damage:
  - When playing distorted sound.
  - When the speakers are reverberating due to a record player, noise from FM broadcasts, or continuous signals from an oscillator, test disc, or electronic instrument.
  - When adjusting the sound quality.
  - When turning the unit on or off.

## If irregular coloring occurs on your television

The front and center speakers are designed to be used close to a television, but the picture may be affected with some televisions and setup combinations.

**If this occurs, turn the television off for about 30 minutes.**

The demagnetizing function of the television should correct the problem. If it persists, move the speakers further away from the television.



## Caution

- The main unit and supplied speakers are to be used only as indicated in this setup. Failure to do so may lead to damage to the amplifier and/or the speakers, and may result in the risk of fire. Consult a qualified service person if damage has occurred or if you experience a sudden change in performance.
- Do not attempt to attach these speakers to walls using methods other than those described in this manual.

## Avoiding interference

To avoid possible interference, do not place the wireless system near any of the following devices.

The wireless system uses the same radio frequencies as other devices that may be present in your home.

e.g.

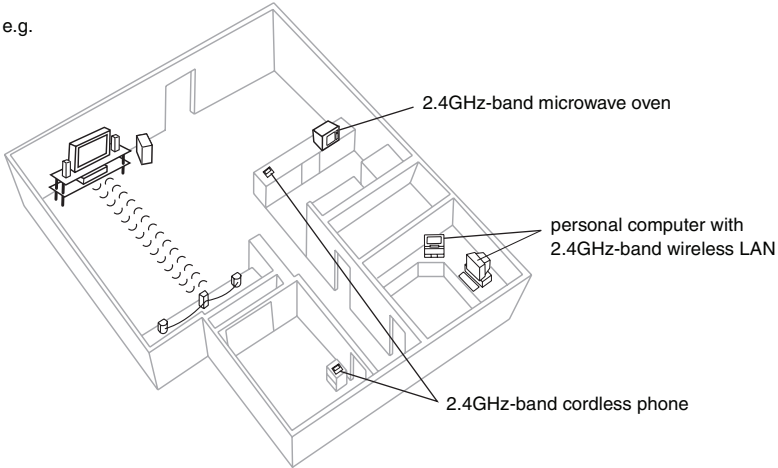

The wireless system will automatically seek a clear channel if any of these other devices interfere with its communication. When this happens, the wireless link indicator (“W”) flashes on the main unit, and there is a brief interruption in audio coming from the surround speakers.

This is the normal operation of the product working to assure the best possible performance of your Home Theater System.

If the interference persists, try moving the other devices to another location outside the range of the wireless system.

## Speaker installation options

### Attaching to a wall

You can attach all of the speakers to a wall.

- The wall or pillar on which the speakers are to be attached should be capable of supporting 10 kg (22 lbs) per screw. Consult a qualified building contractor when attaching the speakers to a wall. Improper attachment may result in damage to the wall and speakers.

① Drive a screw (not included) into the wall.

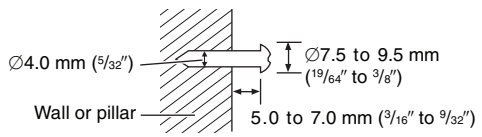

② Fit the speaker securely onto the screw(s) with the hole(s).

Front speaker

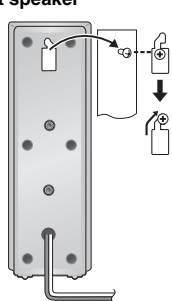

Center speaker

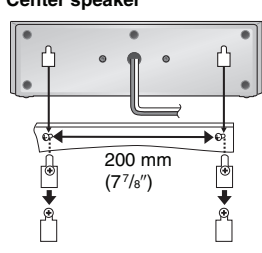

Surround speaker

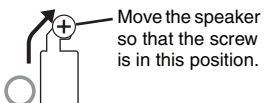
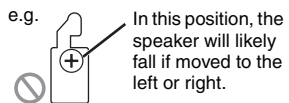
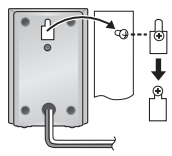

### Fitting speaker stands (not included)

Ensure the stands meet these conditions before purchasing them.

Note the diameter and length of the screws and the distance between screws as shown in the diagram.

- The stands must be able to support over 10 kg (22 lbs).
- The stands must be stable even if the speakers are in a high position.

e.g. Center speaker

Metal screw holes  
For attaching to  
speaker stands

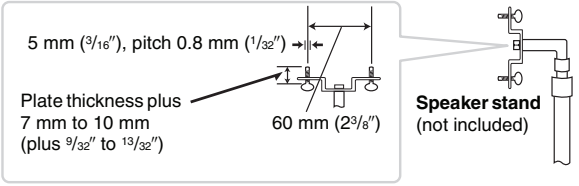
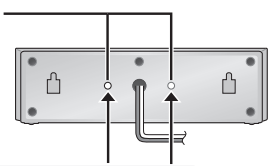



# STEP 3

## Radio and digital transceiver connections

AM loop antenna



FM indoor antenna



Digital transceiver



• Using an outdoor antenna (optional) (→ page 27).

### AM loop antenna

Stand the antenna up on its base. Place the antenna where reception is best. Keep loose antenna cable away from other wires and cables.

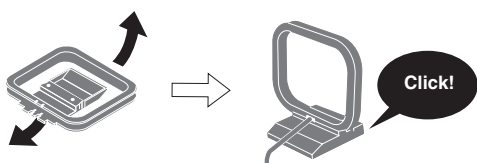

### XM Connect & Play or XMPassport system (not included)

To prevent interference with wireless equipment, place the antenna away from this unit, Panasonic wireless sound system SH-FX80, Panasonic wireless system SH-FX50/SH-FX60, and other equipment that emits radio waves (such as radio equipment and microwave ovens). Refer to page 28 for optimizing the reception.

### XM Connect & Play or XMPassport system



### FM indoor antenna

Affix this end of the antenna where reception is best.

Adhesive tape

### Main unit

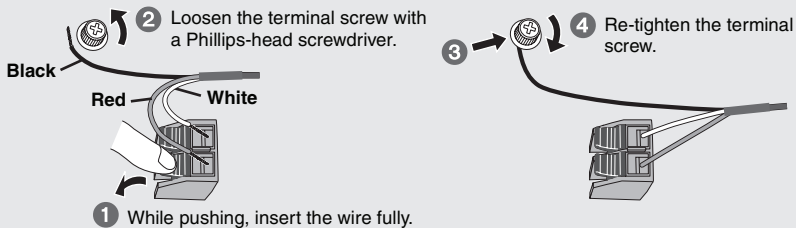

## Connecting the digital transceiver

### Main unit

### DIGITAL TRANSCEIVER

Insert the digital transceiver into the slot.

**Do not insert or remove while the main unit is on.**

### Digital transceiver

Insert fully until you hear a click.

# STEP 4 Audio and video connections

- Do not connect through the video cassette recorder.  
Due to copy guard protection, the picture may not be displayed properly.
- Turn the television off before connecting, and refer to the television's operating instructions.

Video cable



## Basic audio connection

Television (not included)

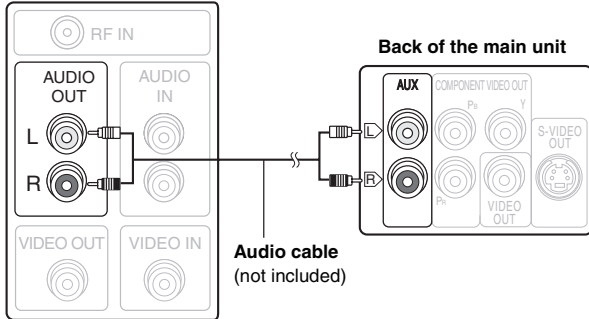

- This audio connection will enable you to play audio from your television through your home theater system. Refer to "Operating other equipment" (→ page 31).

## Basic video connection

Television (not included)

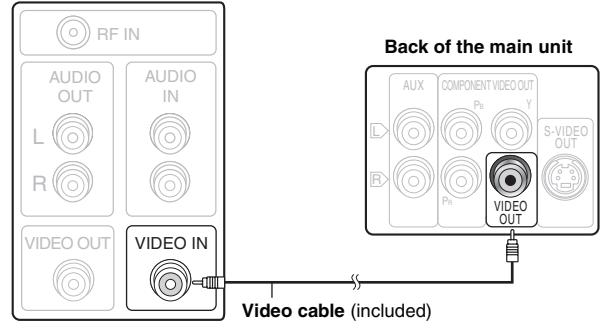

- Refer also to "Other video connections for improved picture quality" (→ below).

## Other video connections for improved picture quality

### S-VIDEO OUT

Television (not included)

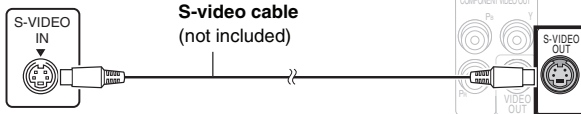

- Using the S-VIDEO OUT terminal

The S-VIDEO OUT terminal achieves a more vivid picture than the VIDEO OUT terminal by separating the chrominance (C) and luminance (Y) signals. (Actual results depend on the television.)

### COMPONENT VIDEO OUT

Television (not included)

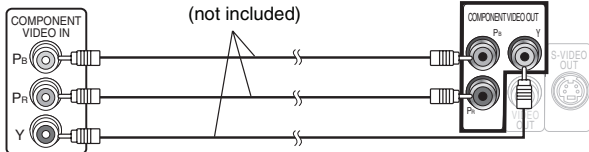

- Using the COMPONENT VIDEO OUT terminals

The COMPONENT VIDEO OUT terminals provides a purer picture than the S-VIDEO OUT terminal. These terminals can be used for either interlaced or progressive output. Connection using these terminals outputs the color difference signals (P<sub>B</sub>/P<sub>R</sub>) and luminance signal (Y) separately in order to achieve high fidelity in reproducing colors.

- The description of the component video input terminals depends on the television or monitor (e.g. Y/P<sub>B</sub>/P<sub>R</sub>, Y/B-Y/R-Y, Y/C<sub>B</sub>/C<sub>R</sub>). Connect to terminals of the same color.
- After making this connection, select "Darker" from the "Black Level Control" in the "Video" tab (→ page 24).

### To enjoy progressive video

- Connect to a progressive output compatible television.
- Set "Video Output Mode" to "480p", and then follow the instructions on the menu screen (→ page 21, Picture Menu).
- All Panasonic televisions that have 480p input connectors are compatible. Consult the manufacturer if you have another brand of television.



## ■ Cable TV box or video cassette recorder connection

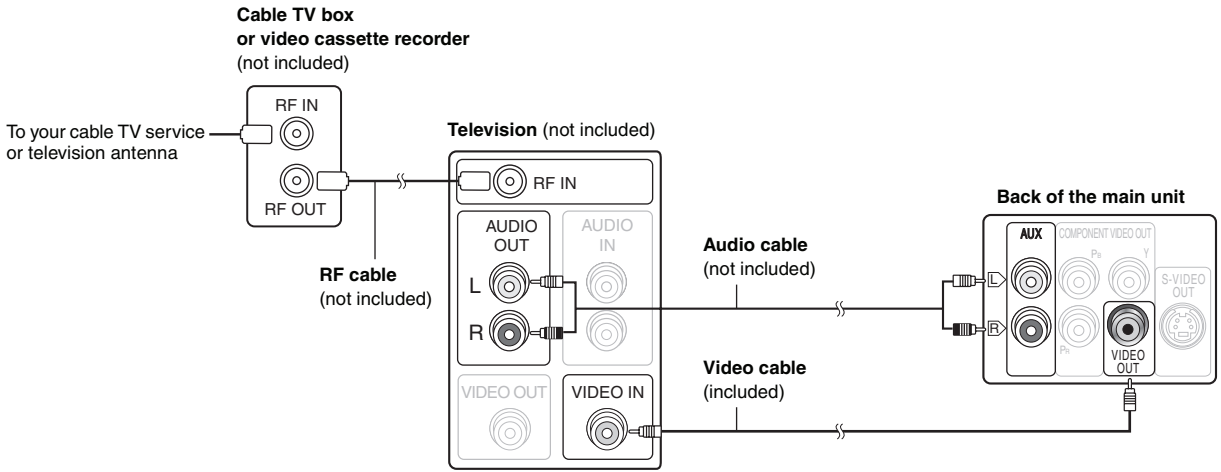

## STEP 5 AC cord connections

### 2 AC power supply cords



#### Main unit

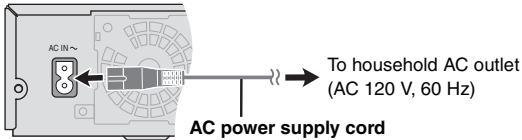

#### Wireless system

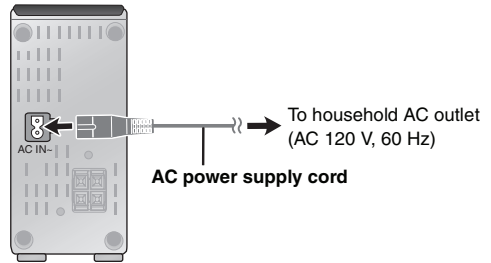

### Conserving power

The main unit and the wireless system consume a small amount of power when they are in standby mode [main unit: approx. 0.5 W, wireless system: 0.5 W (in transmit mode), 1.2 W (in receive mode)]. To save power when they are not to be used for a long time, unplug them from the household AC outlet.

You will need to reset some memory items after plugging in the main unit.

### Note

The included AC power supply cords are for use with the main unit and wireless system only. Do not use them with other equipment. Also, do not use cords for other equipment with the main unit or wireless system.

## STEP 6 Preparing the remote control

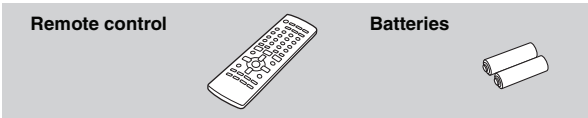

2 Insert so the poles (+ and -) match those in the remote control.

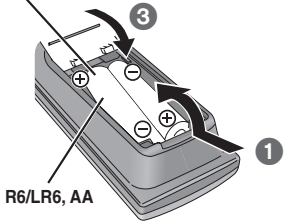

1 Do not use rechargeable type batteries.

### Do not:

- mix old and new batteries.
  - use different types at the same time.
  - heat or expose to flame.
  - take apart or short circuit.
  - attempt to recharge alkaline or manganese batteries.
  - use batteries if the covering has been peeled off.
- Mishandling of batteries can cause electrolyte leakage which can severely damage the remote control.

Remove the batteries if the remote control is not going to be used for a long period of time. Store in a cool, dark place.

### Use

Aim at the display (→ page 11), avoiding obstacles, at a maximum range of 7 m (23 feet) directly in front of the unit.

## STEP 7 Performing QUICK SETUP

The QUICK SETUP screen assists you to make necessary settings.

To display the picture from the main unit, turn on your television and change its video input mode (e.g. VIDEO 1, AV 1, etc.).

- To change your television's video input mode, refer to its operating instructions.
- This remote control can perform some basic television operations (→ page 31).

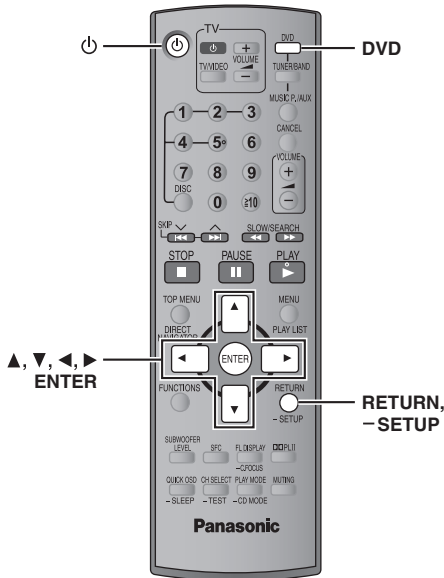

1		Turn on the unit.
2		Select "DVD/CD".
3		Press and hold to show the QUICK SETUP screen.
4	Select Register  RETURN	Follow the messages and make the settings.
5		Press to finish QUICK SETUP.
6		Press repeatedly to exit.

To change these settings later

Select "QUICK SETUP" in the "Others" tab (→ page 24).

See page references in parentheses.

**Television operations (31)**

Turn the unit on/off (10)

Change the television's video input mode (31)

Select disc's title numbers etc./Enter numbers (15)

Select the disc or show disc information (16)

Select preset radio stations/channels (26, 29)

Show a disc top menu (18) or program list (19)

Frame-by-frame/Select or register menu items on the television screen (15)/Browse XM radio categories (29)

Show on-screen menu (20)

Adjust the television volume (31)

Select the source  
DVD: DVD/CD (10)  
TUNER/BAND: FM/AM (26), XM (28)  
MUSIC P./AUX: FRONT MUSIC P./REAR MUSIC P.\* (32),  
AUX (31)

Cancel (15)

Adjust the volume of the main unit (15)

Select radio stations/channels manually (26, 29)

Basic operations for play (14, 15)

Show a disc menu (18) or play list (19)

Return to previous screen (15) or show the setup menu (23)

SUBWOOFER LEVEL (30)	SFC (30)	FL DISPLAY (15, 26, 30)	DDPLI (30)
QUICK OSD (16, 32)	CH SELECT (31)	PLAY MODE (16, 17, 28)	MUTING (32)
-SLEEP	-TEST	-CD MODE	-CD MODE

**To use functions labeled with "—":**  
Press and hold the button for at least 2 seconds.

## Standby/on switch [POWER $\odot$ /I]

Press to switch the unit from on to standby mode or vice versa. In standby mode, the unit is still consuming a small amount of power. (14)

**MUSIC PORT**  
Connect an external device (32)

**SURROUND MUSIC**  
Equalizing the sound (14)

**5 DISC SELECTOR**  
Select the disc tray (14)

**■ / -TUNE MODE / —FM MODE**  
Stop playing (14)  
Select the tuning mode (26, 28)  
Adjust the FM reception condition (26)

**► / MEMORY**  
Play discs (14)/Memorize the receiving radio stations/channels (26, 29)

**▲ OPEN/CLOSE**  
Open/Close the disc drawer (14)

**DISC EXCHANGE**  
Open the disc drawer to exchange the disc in the play position (14)

**DISC SKIP**  
Skip to the next disc tray (14)

**Phones**  
Connect headphones (32)

**VOLUME**  
Turn up/down the volume (14)

**SELECTOR (26)**  
DVD/CD→FM→AM→XM→AUX→FRONT MUSIC P.→  
REAR MUSIC P.\*→Return to DVD/CD

**AC supply indicator [AC IN]**  
This indicator lights when the unit is connected to the AC mains supply.

The unit is in the standby condition when the AC power supply cord is connected. The primary circuit is always "live" as long as the power cord is connected to an electrical outlet.



**MUSIC PORT**  
Connect an external device (32)







**Lighting Ring**  
Lights when the wireless link is active.

\*Refer to page 32, Using the Music Port.



# Discs that can be played

Operations in these instructions are described mainly with formats. Icons such as **DVD-V** show the formats.

	<b>DVD-Video</b> <b>DVD-V</b> —
	<b>DVD-Audio</b> <b>DVD-A</b> <b>DVD-V</b> • <b>DVD-V</b> Some DVD-Audio discs contain DVD-Video content. To play DVD-Video content, select "Play as DVD-Video" in Other Menu (→ page 22).
	<b>Video CD</b> <b>VCD</b> • Including SVCD (Conforming to IEC62107)
	<b>DVD-RAM</b> <b>DVD-VR</b> <b>JPEG</b> • <b>DVD-VR</b> Recorded with devices using Version 1.1 of the Video Recording Format (a unified video recording standard), such as DVD video recorders, DVD video cameras, personal computers, etc. • <b>JPEG</b> Recorded with Panasonic SD multi cameras or DVD video recorders using the DCF (Design rule for Camera File system) Standard Version 1.0.
	<b>DVD-R (DVD-Video)/DVD-RW (DVD-Video)</b> <b>DVD-V</b> • Discs recorded and finalized* on DVD video recorders or DVD video cameras.
—	<b>+R (Video)/+RW (Video)</b> <b>DVD-V</b> • Discs recorded and finalized* on DVD video recorders or DVD video cameras.
	<b>CD</b> <b>CD</b> <b>WMA</b> <b>MP3</b> <b>JPEG</b> <b>VCD</b> • This unit can play CD-R/RW recorded with the above formats. Close the sessions or finalize* the disc after recording. • <b>CD</b> This unit is compatible with HDCD, but does not support the Peak Extend function (a function which expands the dynamic range of high-level signals). HDCD-encoded CDs sound better because they are encoded with 20 bits, as compared with 16 bits for all other CDs. • <b>WMA</b> <b>MP3</b> <b>JPEG</b> This unit also plays HighMAT discs. • <b>WMA</b> This unit does not support Multiple Bit Rate (MBR: an encoding process for audio content that produces an audio file encoded at several different bit rates).

\* A process that allows play on compatible equipment.

• It may not be possible to play all the above-mentioned discs in some cases due to the type of disc or condition of the recording.

## Discs that cannot be played

DVD-RW version 1.0, DVD-ROM, CD-ROM, CDV, CD-G, SACD, DivX Video Discs and Photo CD, DVD-RAM that cannot be removed from their cartridge, 2.6-GB and 5.2-GB DVD-RAM, and "Chaoji VCD" available on the market including CVD, DVCD and SVCD that do not conform to IEC62107.

### Note about using a DualDisc

- The digital audio content side of a DualDisc does not meet the technical specifications of the Compact Disc Digital Audio (CD-DA) format so playback may not be possible.
- Do not use a DualDisc in this unit as it may not be possible to insert it correctly and it may get scratched or scraped.

## Disc caution

### To clean discs

Wipe with a damp cloth and then wipe dry.

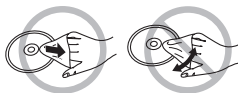

### Disc handling precautions

- Do not attach labels or stickers to discs. This may cause disc warping, rendering it unusable.
- Do not write on the label side with a ball-point pen or other writing instrument.
- Do not use record cleaning sprays, benzene, thinner, liquids which prevent static electricity, or any other solvent.
- Do not use scratch-proof protectors or covers.
- Do not use the following discs:
  - Discs with exposed adhesive from removed stickers or labels (rented discs, etc).
  - Discs that are badly warped or cracked.
  - Irregularly shaped discs, such as heart shapes.

## Maintenance

### Clean this unit with a soft, dry cloth.

- Never use alcohol, paint thinner or benzene to clean this unit.
- Before using chemically treated cloth, carefully read the instructions that came with the cloth.

**Do not use commercially available lens cleaners as they may cause malfunction.** Cleaning of the lens is generally not necessary although this depends on the operating environment.

**Before moving the unit, ensure the disc trays are empty.** Failure to do so will risk severely damaging the discs and the unit.



- 1. Damage requiring service**—The unit should be serviced by qualified service personnel if:
  - (a) The AC power supply cord or AC adaptor has been damaged; or
  - (b) Objects or liquids have gotten into the unit; or
  - (c) The unit has been exposed to rain; or
  - (d) The unit does not operate normally or exhibits a marked change in performance; or
  - (e) The unit has been dropped or the cabinet damaged.
- 2. Servicing**—Do not attempt to service the unit beyond that described in these operating instructions. Refer all other servicing to authorized servicing personnel.
- 3. Replacement parts**—When parts need replacing ensure the servicer uses parts specified by the manufacturer or parts that have the same characteristics as the original parts. Unauthorized substitutes may result in fire, electric shock, or other hazards.
- 4. Safety check**—After repairs or service, ask the servicer to perform safety checks to confirm that the unit is in proper working condition.

The servicer will require all components to service your system. Therefore, should service ever be necessary, be sure to bring the entire system.

## Product information

For product information or assistance with product operation, refer to “Customer Services Directory” on page 38.

## Glossary

### Decoder

A decoder restores the coded audio signals on DVDs to normal. This is called decoding.

### Dolby Digital

This is a method of coding digital signals developed by Dolby Laboratories. Apart from stereo (2-channel) audio, these signals can also be multi-channel audio. A large amount of audio information can be recorded on one disc using this method.

### DTS (Digital Theater Systems)

This surround system is used in many movie theaters around the world. There is good separation between the channels, so realistic sound effects are possible.

### Dynamic range

Dynamic range is the difference between the lowest level of sound that can be heard above the noise of the equipment and the highest level of sound before distortion occurs.

### Frame still and field still

Frames are the still pictures that go together to make a moving picture. There are about 30 frames shown each second.

One frame is made up of two fields. A regular television shows these fields one after the other to create frames.

A still is shown when you pause a moving picture. A frame still is made up of two alternating fields, so the picture may appear blurred, but overall quality is high.

A field still is not blurred, but it has only half the information of a frame still so picture quality is lower.

### I/P/B

MPEG 2, the video compression standard adopted for use with DVD-Video, codes frames using these 3 picture types.

**I:** Intra coded picture

This picture has the best quality and is the best to use when adjusting the picture.

**P:** Predictive coded picture

This picture is calculated based on past I- or P-pictures.

**B:** Bidirectionally-predictive coded picture

This picture is calculated by comparing past and future I- and P-pictures so it has the lowest volume of information.

### JPEG (Joint Photographic Experts Group)

This is a system used for compressing/decoding color still pictures. If you select JPEG as the storage system on digital cameras, etc., the data will be compressed to 1/10–1/100 of its original size. The benefit of JPEG is less deterioration in picture quality considering the degree of compression.

### Linear PCM (pulse code modulation)

These are uncompressed digital signals, similar to those found on CDs.

### MP3 (MPEG Audio Layer 3)

An audio compression method that compresses audio to approximately one tenth of its size without any considerable loss of audio quality.

### Playback control (PBC)

If a Video CD has playback control, you can select scenes and information with menus.

### Progressive/Interlaced

NTSC, the video signal standard, has 480 interlaced (i) scan lines, whereas progressive scanning uses twice the number of scan lines. This is called 480p.

Using progressive output, you can enjoy the high-resolution video recorded on media such as DVD-Video.

Your television must be compatible to enjoy progressive video.

### Sampling frequency

Sampling is the process of converting the heights of sound wave (analog signal) samples taken at set periods into digits (digital encoding). Sampling frequency is the number of samples taken per second, so larger numbers mean more faithful reproduction of the original sound.

### WMA (Windows Media™ Audio)

WMA is a compression format developed by Microsoft Corporation. It achieves the same sound quality as MP3 with a file size that is smaller than that of MP3.

# Basic play

To display the picture from the main unit, turn on your television and change its video input mode (e.g. VIDEO 1, AV 1, etc.).

• To change your television's video input mode, refer to its operating instructions.

## 1 Power on.

POWER



## 2 Select "DVD/CD".

SELECTOR



- Select "AUX" to enjoy video cassette recorder, television or cable TV programs. (Refer to page 8 for the necessary connections.)

## 3 Open the drawer and place the disc(s).

OPEN/CLOSE



- Load double-sided discs so the label for the side you want to play is facing up.
- To load discs on the other trays, press [DISC SKIP] on the main unit.
- Play will start from the disc in the front-left position of the tray.
- For DVD-RAM, remove the disc from its cartridge before use.
- Do not:
  - load more than one disc per tray.
  - touch the drawer or the carousel while they are in motion.
  - rotate the carousel by hand.
  - close the drawer by hand.



## 4 Close the drawer.

OPEN/CLOSE

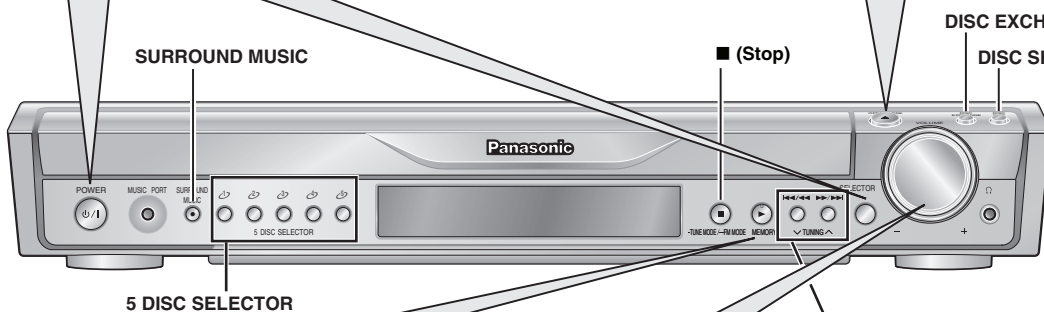

## 5 Start play.



### When the disc finishes playing

If the next disc does not start playing, select it with the 5 DISC SELECTOR buttons.

- You can also select the disc using the remote control (→ page 16, Checking the disc type in each tray).

To change the sound quality → page 30

## 6 Adjust the volume.

VOLUME



### Press to skip.

- search during play
- start slow-motion play during pause (Motion picture part)
- Press [▶] (Play) to start normal play.



## Using the main unit

### Equalizing the sound



- The sound fills the room, and comes from all directions with equal intensity, regardless of your orientation within the room.
- The indicator on the button lights.

### Skipping to the next disc tray



- While the drawer is closed Each time you press the button, the carousel moves counter-clockwise by one tray.

### Exchanging the disc in the play position



- The drawer opens and the disc in the play position comes to the front-left position.
- Press the button again to play the disc after changing the disc in the front-left position.

### Changing the other discs without interrupting play

OPEN/CLOSE



↓

DISC SKIP



↓

Change the discs

↓

OPEN/CLOSE



- Each time you press [DISC SKIP], you can select the other trays.

### Note

- DISCS CONTINUE TO ROTATE WHILE MENUS ARE DISPLAYED. To preserve the unit's motor and your television screen, press [■] (Stop) when you are finished with the menus.
- Total title number may not be displayed properly on +R/+RW.

## Using the remote control

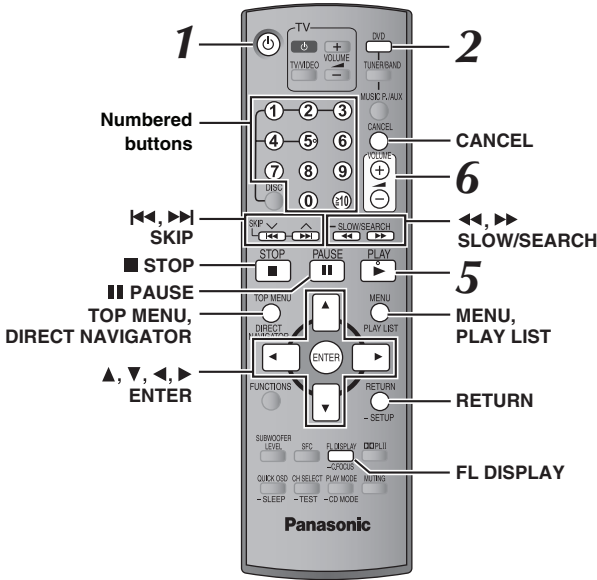

**On-screen item select**

Select

Register

—

**Enter number**

1 2 3  
4 5 6  
7 8 9  
0 (≠10)

DVD-VR DVD-A DVD-V VCD CD  
e.g. To select 12:  
[≧10] → [1] → [2]

VCD with playback control  
Press [■ STOP] to cancel the PBC function, and then press the numbered buttons.

WMA MP3 JPEG  
e.g. To select 123:  
[1] → [2] → [3] → [ENTER]

ENTER

CANCEL

• Press [CANCEL] to cancel the number(s).

**Stop**

STOP

The position is memorized while "RESUME" is on the display.

- Press [▶ PLAY] to resume.
- Press [■ STOP] again to clear the position.

**Pause**

PAUSE

- Press [▶ PLAY] to restart play.

**Skip**

SKIP

- WMA MP3 JPEG  
[This feature does not work during program and random play (→ page 17).]
- [▲, ▼]: **Group skip**
- [◀, ▶]: **Content skip**

**Search**  
(during play)

SLOW/SEARCH

- Up to 5 steps.
- Press [▶ PLAY] to start normal play.

**Slow-motion**  
(during pause)

- VCD Slow-motion: forward direction only.

**Frame-by-frame**  
(during pause)

DVD-A (Motion picture part)  
DVD-VR DVD-V VCD

- VCD Forward direction only.

**Disc menu**

TOP MENU

DIRECT NAVIGATOR

DVD-A DVD-V  
Shows a disc top menu.

DVD-VR  
Press the button to show the programs (→ page 19).

**Disc menu**

MENU

PLAY LIST

DVD-V  
Shows a disc menu.

DVD-VR  
Press the button to show a play list (→ page 19).

RETURN

VCD with playback control  
Shows a disc menu.

**Return to previous screen**

RETURN

—

**Main unit display**

FL DISPLAY

DVD-VR DVD-A DVD-V VCD CD  
WMA MP3  
Time display  
↔ Information display  
(e.g. DVD-VR Program number)

JPEG  
When Slideshow (→ page 20) is on:  
SLIDE ↔ Contents number  
When Slideshow is off:  
PLAY ↔ Contents number



Basic play

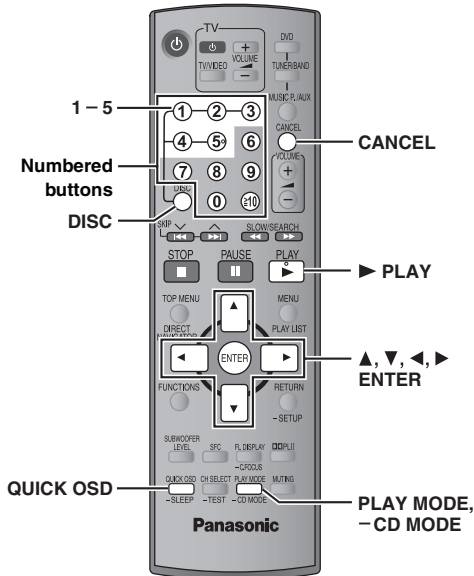

## Checking the disc type in each tray

DISC



You can select the disc after checking the discs loaded with the Disc information screen.

- You can also select the disc directly with the 5 DISC SELECTOR buttons on the main unit.

### 1 Press [DISC] to show the Disc information screen.

- To exit the screen, press [DISC].

e.g.

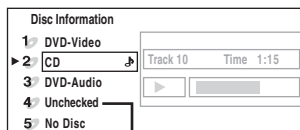

### 2 Press the numbered buttons ([1] - [5]) to select the disc.

## Displaying current playback condition

QUICK OSD



Press [QUICK OSD].

- To exit the screen, press [QUICK OSD].

e.g. [DVD-V]

Current playback number Elapsed play time

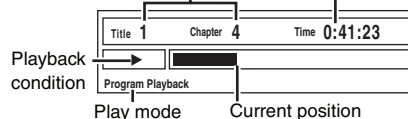

## Playing CDs sequentially

[VCD] [CD] [WMA] [MP3]

-CD MODE



This feature is very convenient if you want to play several music CDs sequentially. Make sure that applicable disc is in the play position before playing (→ Checking the disc type in each tray, left).

While stopped

### 1 Press and hold [-CD MODE].



### 2 Press [▶ PLAY].

- If all loaded discs are DVDs or if other discs are unchecked, CD Mode does not work.
- HighMAT menus and Video CD playback control are disabled.
- You cannot turn CD Mode on or off during program or random play.
- If you want to play a DVD, press and hold [-CD MODE] again to cancel CD Mode. (CD Mode is also canceled when you switch the unit to standby, select another source, or change the disc in the play position.)
- DVD and JPEG are skipped without being played.



## Program and Random play

PLAY MODE



### Press [PLAY MODE] while stopped.

Program and random playback screens appear sequentially.

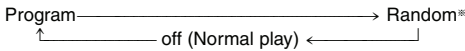

\*"RANDOM 1" and "RANDOM 2" (→ right) are displayed on the main unit's display when CD Mode is on (→ page 16).

### To exit the program and random mode

Press [PLAY MODE] several times while stopped.

- Selecting "Play as Data Disc" in Other Menu (→ page 22) will be effective if the following functions are not available to play WMA, MP3 or JPEG files.
- **DVD-V** Some items cannot be played even if you have programmed them.
- **DVD-A** Some discs contain bonus groups. If a password screen appears after selecting a group, enter the password with the numbered buttons to play the bonus group. Refer also to the disc's jacket.

## Program play (up to 32 items)

### ■ When CD Mode is off

**DVD-A DVD-V VCD CD WMA MP3 JPEG**

You can program all the items on a disc in the play position.

#### ① **VCD CD** Skip to step ②

Press the numbered buttons to select a group or title.

**(WMA MP3 JPEG)** Press [ENTER] to register the selection.)

e.g. **DVD-V**

T/G: Title/Group  
C/T: Chapter, Content/  
Track

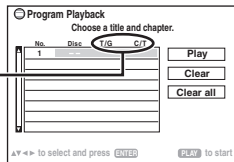

- To select a 2-digit number  
e.g. To select 12: [≥10] → [1] → [2]  
**(WMA MP3 JPEG)** [1] → [2] → [ENTER]

#### ② Press the numbered buttons to select a chapter or track. **(WMA MP3 JPEG)** Press [ENTER] to register the selection.)

- Repeat steps ① and ② to program other items.

#### ③ Press **[▶ PLAY]**.

### ■ When CD Mode is on (→ page 16)

**VCD CD WMA MP3**

You can program all the items on all the discs.

#### ① Press the numbered buttons ([1] – [5]) to select a disc.

#### ② **(WMA MP3)** Press the numbered buttons to select a group. (Press [ENTER] to register the selection.)

- To select a 2-digit number  
e.g. To select 12: [1] → [2] → [ENTER]

#### ③ Press the numbered buttons to select a track.

**(WMA MP3)** Press [ENTER] to register the selection.)

- To select a 2-digit number  
e.g. To select 12: [≥10] → [1] → [2]  
**(WMA MP3)** [1] → [2] → [ENTER]

- Repeat steps ① to ③ to program other items.

#### ④ Press **[▶ PLAY]**.

### To select an item using the cursor buttons

Press [ENTER] and [▲, ▼] to select an item, and then press [ENTER] again to register.

### To change the selected program

- 1 Press [▲, ▼] to select the program number.
- 2 Press the numbered buttons to change each item.  
**(WMA MP3)** Press [ENTER] to register the selection.)

### To clear the selected program

- 1 Press [▲, ▼] to select the program number.
- 2 Press [CANCEL] (or press [▲, ▼, ◀, ▶] to select "Clear" and press [ENTER]).

### To clear the whole program

Select "Clear all" with [▲, ▼, ◀, ▶] and press [ENTER].

The whole program is also cleared when the disc is moved out of the play position, the unit is turned off or another source is selected.

## Random play

### ■ When CD Mode is off

**VCD CD**

You can play all the items on a disc in the play position in random order.

**DVD-A DVD-V WMA MP3 JPEG**

You can play selected item(s) on a disc in the play position in random order.

#### ① **DVD-A DVD-V WMA MP3 JPEG**

Press the numbered buttons to select a group or a title.

**(WMA MP3 JPEG)** Press [ENTER] to register the selection.)

e.g. **DVD-V**

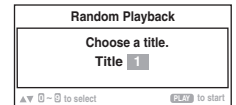

**DVD-A**

- To enter all groups, press [◀, ▶] to select "All" and press [ENTER].
- To deselect a group, press numbered buttons corresponding to the group you want to clear.

#### ② Press **[▶ PLAY]**.

### ■ When CD Mode is on (→ page 16)

**VCD CD WMA MP3**

You can select either "RANDOM 1" or "RANDOM 2".

#### • RANDOM 1

You can play all the items on all the discs in random order.



#### • RANDOM 2

You can play all the discs in sequence, but all the items on each disc are played in random order.



Press **[▶ PLAY]**.

e.g. **CD**

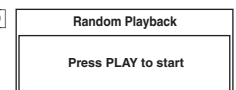

# Playing data discs using navigation menus

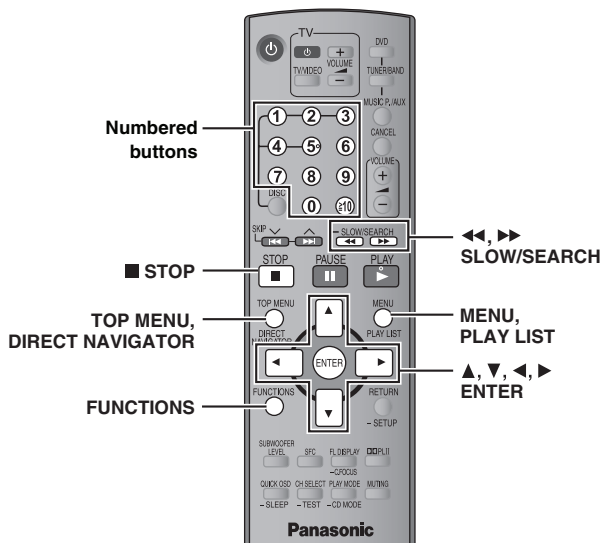

## Using the submenu

- While Navigation Menu is displayed Press [FUNCTIONS].
- Press [▲, ▼] to select an item and press [ENTER]. Items shown differ depending on the type of disc.

Multi	Groups and contents are displayed.
List	Contents only
Tree	Groups only
Thumbnail	Thumbnail images [JPEG]
Next group	To go to next group [WMA] [MP3]
Previous group	To go to previous group [WMA] [MP3]
All	WMA/MP3 and JPEG
Audio	WMA/MP3 only
Picture	JPEG only
Help display	To switch between guide messages and the elapsed play time indicator
Find	To search by content or group title (→ below)

## Searching by a content or group title

Highlight a group title to search the group, or a content title to search its content.

- While the submenu is displayed (→ above) Press [▲, ▼] to select "Find" and press [ENTER].



- Press [▲, ▼] to select a character and press [ENTER].
  - Repeat to enter another character.
  - Lower case characters are also searched.
  - Press [◀, ▶] SLOW/SEARCH to skip between A, E, I, O and U.
  - Press [◀] to erase a character.
  - Leave the asterisk (\*) when you search for the titles including the character you enter.
  - Erase the asterisk (\*) to search for the titles starting with the character you enter. To add the asterisk (\*) again, display the submenu again and select "Find".
- Press [▶] to select "Find" and press [ENTER]. The search result screen appears.
- Press [▲, ▼] to select the content or group and press [ENTER].

## Playing data discs

WMA MP3 JPEG

TOP MENU / MENU

Selecting "Play as Data Disc" in Other Menu (→ page 22) will be effective if the following functions are not available to play WMA, MP3 or JPEG files.

- Playing HighMAT™ discs (→ page 19)

## Playing items in order (Playback Menu)

(Except JPEG files on DVD-RAM)

- Press [TOP MENU].
  - To exit the screen, press [TOP MENU].

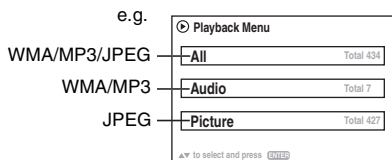

- Press [▲, ▼] to select "All", "Audio" or "Picture" and press [ENTER].

## Playing from the selected item (Navigation Menu)

- Press [MENU].
  - To exit the screen, press [MENU].

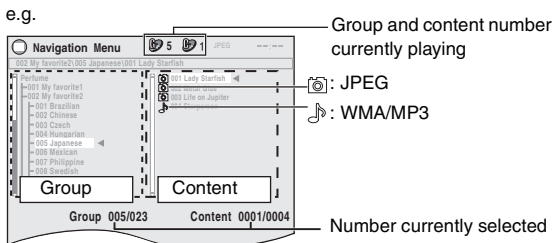

- Press [▲, ▼, ◀, ▶] to select the group and press [ENTER].
- To play content in the group in order Press [ENTER]. To start play from the selected content Press [▲, ▼] to select and [ENTER].

## Selecting a track using CD text

CD

TOP MENU / MENU

Titles appear with CD Text disc playback.

- Press [TOP MENU] or [MENU].
  - To exit the screen, press [TOP MENU] or [MENU].

e.g. CD text
- Press [▲, ▼] to select the track and press [ENTER].
  - Press [FUNCTIONS] to show the playback condition and current position.

To enjoy listening to WMA/MP3 contents while showing a JPEG image on the screen, select a JPEG file first and then select audio contents. (The opposite order is not effective.)

## Playing HighMAT™ discs

WMA MP3 JPEG

TOP MENU / MENU



- 1 Press [TOP MENU].
  - To exit the screen, press [STOP].
  - To change the menu background to the one recorded on the disc, press [FUNCTIONS].
- 2 Press [▲, ▼, ◀, ▶] to select the item, and then press [ENTER].
  - Repeat this step if necessary.

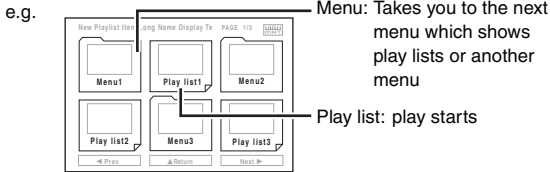

## Selecting from the list

- 1 During play Press [MENU].
  - To exit the screen, press [MENU].



- 2 Press [◀] followed by [▲, ▼] to switch among "Playlist", "Group" and "Content" lists.
- 3 Press [▶] followed by [▲, ▼] to select an item and press [ENTER].

## Playing RAM discs

DVD-VR

DIRECT NAVIGATOR / PLAY LIST

- Titles appear only if the titles are recorded on the disc.
- You cannot edit programs, play lists and disc titles.

## Playing the programs

- 1 Press [DIRECT NAVIGATOR].
  - To exit the screen, press [DIRECT NAVIGATOR].

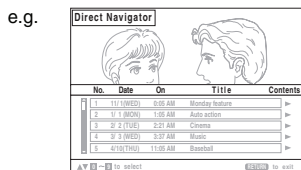

- 2 Press [▲, ▼] or the numbered buttons to select the program.
  - To select a 2-digit number  
e.g. 12: [≥10] → [1] → [2]
  - Press [▶] to show the contents of the program and the disc.
- 3 Press [ENTER].

## Playing a play list

This works only when the disc contains a play list.

- 1 Press [PLAY LIST].
  - To exit the screen, press [PLAY LIST].

e.g.



- 2 Press [▲, ▼] or the numbered buttons to select the play list.
  - To select a 2-digit number  
e.g. 12: [≥10] → [1] → [2]

- 3 Press [ENTER].

## Tips for making data discs

- When there are more than 8 groups, the eighth group onwards will be displayed on one vertical line in the menu screen.
- There may be differences in the display order on the menu screen and computer screen.
- This unit cannot play files recorded using packet write.

### DVD-RAM

- Discs must conform to UDF 2.0.

### CD-R/RW

- Discs must conform to ISO9660 level 1 or 2 (except for extended formats).
- This unit supports multi-session but if there are many sessions it takes more time for play to start. Keep the number of sessions to a minimum to avoid this.

### Naming folders and files (Files are treated as contents and folders are treated as groups on this unit.)

At the time of recording, prefix folder and file names. This should be with numbers that have an equal number of digits, and should be done in the order you want to play them (this may not work at times).

Files must have the extension (→ below).

**WMA** (Extension: ".WMA" or ".wma")

- You cannot play WMA files that are copy-protected.
- This unit does not support Multiple Bit Rate (MBR).

**MP3** (Extension: ".MP3" or ".mp3")

- This unit does not support ID3 tags.
- Compatible sampling rates: 8, 11.02, 12, 16, 22.05, 24, 32, 44.1 and 48 kHz.

**JPEG** (Extension: ".JPG", ".jpg", ".JPEG" or ".jpeg")

- To view JPEG files on this unit:
  - Take them on a digital camera that meets the DCF Standard (Design rule for Camera File system) Version 1.0. Some digital cameras have functions that are not supported by the DCF Standard Version 1.0 like automatic picture rotation which may render a picture unviewable.
  - Do not alter the files in any way or save them under a different name.
- This unit cannot display moving pictures, MOTION JPEG and other such formats, and still pictures other than JPEG (e.g. TIFF), or play pictures with attached audio.

e.g. MP3

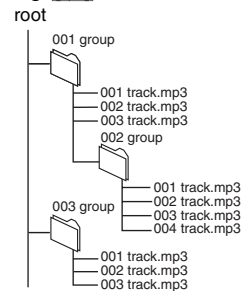

# Using on-screen menus

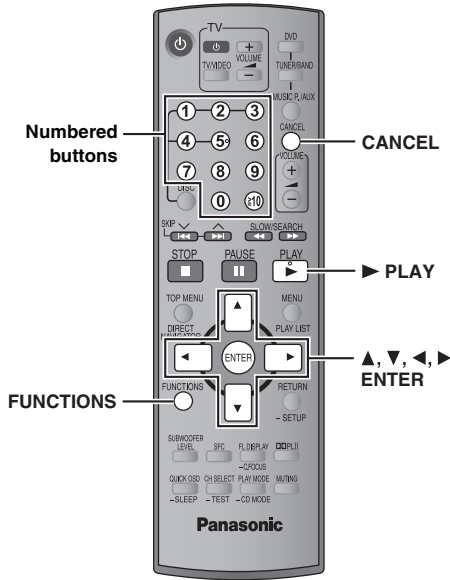

<b>1</b>	FUNCTIONS 	<b>Press once.</b>
<b>2</b>	Select  Go to the next menu Register Return to the previous menu	<b>Select the menu.</b> e.g. DVD-V 
<b>3</b>	Select Register  1 2 3 4 5 6 7 8 9 0 10	<b>Make the settings.</b> e.g. DVD-V 
<b>4</b>	FUNCTIONS 	<b>Press to exit.</b>

## Main menu

Items shown differ depending on the type of disc.

Program Group Title Chapter Track Playlist Content	<b>To start from a specific item</b> e.g. DVD-VR To select Program 12 Press the numbered buttons: [1] → [2] → [ENTER] 
Time	(Time Slip and Time Search do not work with +R/+RW discs.) <b>To skip incrementally or decrementally (Time Slip for play only)</b> 1 Press [ENTER] twice to show the Time Slip indicator. 2 Press [▲, ▼] to select the time and press [ENTER]. • To change the steps more quickly, press and hold [▲, ▼]. <b>To start from a specific time (Time Search)</b> <b>To change remaining/elapsed time display</b>
Audio	DVD-A DVD-V (with multiple soundtracks) <b>To select audio soundtrack</b> DVD-VR VCD <b>To select "L", "R" or "LR"</b> DVD-V (Karaoke disc) <b>To select "On" or "Off" for vocals</b> • Read the disc's instructions for details. <b>Signal type/data</b> LPCM/PPCM/Digital/DTS/MPEG: Signal type kHz (Sampling frequency)/bit/ch (Number of channels) e.g. 3/2_1ch .1: Low frequency effect (not displayed if there is no signal) 0: No surround 1: Mono surround 2: Stereo surround (left/right) 1: Center 2: Front left+ Front right 3: Front left+ Front right+ Center WMA MP3 <b>To display the current bitrate or sampling frequency</b>

Still Picture	<b>To switch still pictures</b>
Thumbnail	<b>To show thumbnail images</b>
Subtitle	DVD-V (with multiple subtitles) VCD (SVCD only) <b>To select subtitle language</b> • On +R/+RW, a subtitle number may be shown for subtitles that are not displayed. • DVD-VR "On" or "Off" appears only with discs that contain subtitle on/off information (Subtitle on/off information cannot be recorded using Panasonic DVD Recorders).
Marker (VR)	DVD-VR <b>To recall a marker recorded on DVD-Video recorders</b> Press [▲, ▼] → Press [ENTER].
Angle	(with multiple angles) <b>To select a video angle</b>
Rotate Picture	<b>To rotate a picture</b>
Slideshow	<b>To turn on/off slideshow</b> On ↔ Off <b>To change the slideshow timing</b> 0 – 30 sec
Other Settings	(→ page 21)

<b>Play Speed</b>	<p><b>DVD-A</b> (Motion picture part) <b>DVD-VR</b> <b>DVD-V</b></p> <p><b>To change play speed</b>                      – from “×0.6” to “×1.4”</p> <ul style="list-style-type: none"> <li>● Press [▶] PLAY] to return to normal play.</li> <li>● After you change the speed                             <ul style="list-style-type: none"> <li>– Dolby Pro Logic II and Sound Enhancement have no effect.</li> <li>– Audio output switches to 2-channel stereo (except when Surround Music is on).</li> <li>– Sampling frequency of 96 kHz is converted to 48 kHz.</li> </ul> </li> <li>● This function may not work depending on the disc’s recording.</li> </ul>
-------------------	--

■ **Play Menu**

This works only when the elapsed play time can be displayed. It also works with all JPEG content.

<b>Repeat</b>	<p><b>DVD-VR</b>: Program→Disc→Off</p> <ul style="list-style-type: none"> <li>● During play list play: Scene→Playlist→Off</li> </ul> <p><b>DVD-A</b>: Track→Group*→Off</p> <p><b>DVD-V</b>: Chapter→Title*→Off</p> <p><b>VCD</b> <b>CD</b>: Track→Disc*→Off</p> <ul style="list-style-type: none"> <li>● When CD Mode is on: Track→Disc→All CD’s→Off</li> <li>● When CD Mode is on during program or random play: Track→All CD’s→Off</li> </ul> <p><b>WMA</b> <b>MP3</b>: Content→Group*→Off</p> <ul style="list-style-type: none"> <li>● When CD Mode is on: Content→Group→All CD’s→Off</li> <li>● When CD Mode is on during program or random play: Content→All CD’s→Off</li> </ul> <p><b>JPEG</b>: Group*→Off</p> <p>*“All” is displayed during program and random play.</p>
---------------	---

<b>A-B Repeat</b>	<p>Except <b>JPEG</b> <b>DVD-VR</b> (Still picture part)</p> <p><b>To repeat a specified section</b>                      Press [ENTER] at the starting and ending points.                      Press [ENTER] again to cancel.</p>
-------------------	--

<b>Marker</b>	<p>Except <b>DVD-VR</b></p> <p><b>To mark up to 5 positions to play again</b>                      Press [ENTER] (The unit is now ready to accept markers.)</p> <p>To mark a position:                      Press [ENTER] (at the desired point).</p> <p>To mark another position:                      Press [◀, ▶] to select “*” → Press [ENTER].</p> <p>To recall a marker:                      Press [◀, ▶] → Press [ENTER].</p> <p>To erase a marker:                      Press [◀, ▶] → Press [CANCEL].</p> <ul style="list-style-type: none"> <li>● This feature does not work during program and random play.</li> <li>● Markers you add are cleared when you change the disc in the play position or switch the unit to standby.</li> </ul>
---------------	--

<b>Advanced Disc Review</b>	<p><b>DVD-VR</b> (Except still picture part)</p> <p><b>DVD-V</b> (Except +R/+RW)</p> <p>Allows you to browse the disc contents and start playing from the selected position. You can select either “Intro Mode” or “Interval Mode” in “Advanced Disc Review” in the “Disc” tab (→ page 23).</p> <p><b>When you find a title/program to play</b>                      Press [▶] PLAY].</p> <ul style="list-style-type: none"> <li>● This may not work depending on the disc and the play position.</li> <li>● <b>DVD-VR</b> This does not work when playing a playlist (→ page 19).</li> </ul>
-----------------------------	---

■ **Picture Menu**

<b>Picture Mode</b>	<p><b>Normal</b></p> <p><b>Cinema1</b>: Mellows images and enhances detail in dark scenes.</p> <p><b>Cinema2</b>: Sharpens images and enhances detail in dark scenes.</p> <p><b>Animation</b>: Suitable for animation.</p> <p><b>Dynamic</b>: Enhances the contrast for powerful images.</p> <p><b>User</b>: Press [ENTER] to select “Picture Adjustment” (→ below).</p>
	<p><b>Picture Adjustment</b></p> <p><b>Contrast</b>: Increases the contrast between light and dark parts of the picture.</p> <p><b>Brightness</b>: Brightens the picture.</p> <p><b>Sharpness</b>: Adjusts the sharpness of the edges of horizontal lines.</p> <p><b>Color</b>: Adjusts the shade of the picture’s color.</p> <p><b>Gamma</b>: Adjusts the brightness of dark parts.</p> <p><b>Depth Enhancer</b>: Reduces the rough noise in the background to give a greater feeling of depth.</p>
<b>Video Output Mode</b>	<p><b>To select suitable picture quality with your television</b>  <b>480i</b> (interlaced) ↔ <b>480p</b> (progressive)</p> <p>When you select “480p”, a confirmation screen appears. Select “Yes” only if connecting to a progressive output compatible television.</p>
<b>Transfer Mode</b>	<p>If you have chosen “480p” (→ above), select the method of conversion for progressive output to suit the type of material.</p> <p><b>Auto1</b> (normal): Detects 24 frame-per-second film content and appropriately converts it.</p> <p><b>Auto2</b>: Compatible with 30 frame-per-second film content in addition to 24 frame-per-second film content.</p> <p><b>Video</b>: Select when using Auto1 or Auto2, and the video content is distorted.</p>



(Continued on next page)

## Other Settings

Items shown differ depending on the type of disc.

### ■ Audio Menu

<b>Dolby Pro Logic II</b>	(→ page 30, Enhancing the stereo sound: Dolby Pro Logic II)
<b>Dialogue Enhancer</b>	To make the dialogue in movies easier to hear <input type="checkbox"/> <b>DVD-V</b> (Dolby Digital, DTS, 3-channel or higher, with the dialogue recorded in the center channel) <b>On</b> ↔ <b>Off</b>
<b>Sound Enhancement</b>	Enhances audio output to reduce noise and improve clarity. <b>On</b> ↔ <b>Off</b>

### ■ Display Menu

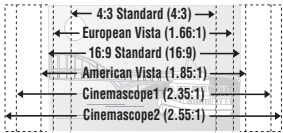
<b>Information</b>	<input type="checkbox"/> <b>JPEG</b> Off, Date, Details
<b>Subtitle Position</b>	0 to -60 (in 2 unit steps)
<b>Subtitle Brightness</b>	Auto, 0 to -7
<b>4:3 Aspect</b>	To select how to show images made for 4:3 aspect screens on a 16:9 aspect television  <b>Normal:</b> Laterally stretches images. <b>Auto:</b> Expands 4:3 letterbox images to fill more of the screen. Other images appear in full in the center of the screen. <b>Shrink:</b> Images appear in the center of the screen. <b>Zoom:</b> Expands all images to fill the screen. If your television has a similar feature, use it instead for a better effect.
<b>Just Fit Zoom</b>	To select the appropriate screen size to fit your television screen  <input type="checkbox"/> <b>DVD-A</b> (Motion picture part) <input type="checkbox"/> <b>DVD-VR</b> <input type="checkbox"/> <b>DVD-V</b> <input type="checkbox"/> <b>VCD</b> <b>Auto, 4:3 Standard, European Vista, 16:9 Standard, American Vista, Cinemascope1, Cinemascope2</b> e.g. 
<b>Manual Zoom</b>	To zoom in and out manually – in 0.01-unit steps from “×1.00” to “×1.60” – in 0.02-unit steps from “×1.60” to “×2.00” • To change the steps more quickly, press and hold [ <b>▲</b> , <b>▼</b> ].
<b>Bit Rate Display</b>	<input type="checkbox"/> <b>DVD-A</b> (Motion picture part) <input type="checkbox"/> <b>DVD-VR</b> <input type="checkbox"/> <b>DVD-V</b> <input type="checkbox"/> <b>VCD</b> <b>On</b> ↔ <b>Off</b>
<b>GUI See-through</b>	To make the on-screen menu transparent <b>Off, On, Auto</b>
<b>GUI Brightness</b>	To adjust the on-screen menu brightness –3 to +3

### ■ Other Menu

<b>Setup</b>	(→ page 23)
<b>Play as DVD-Video</b> or <b>Play as DVD-Audio</b>	To play DVD-Video contents of DVD-Audio Select “Play as DVD-Video”.
<b>Play as DVD-VR,</b> <b>Play as HighMAT</b> or <b>Play as Data Disc</b>	To use functions for data discs (→ page 18) Select “Play as Data Disc”.



# Changing the player settings

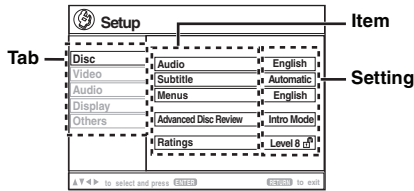
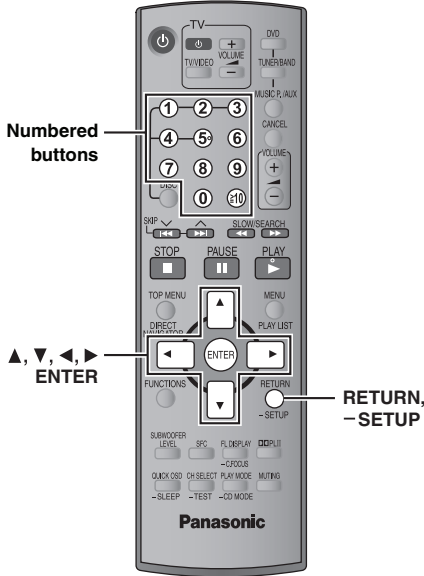

- The settings remain intact even if you switch the unit to standby.
- Underlined items are the factory settings in the following table.

1		<p><b>Press and hold to show the Setup menu.</b> If you have not performed QUICK SETUP (→ page 10), the QUICK SETUP screen appears.</p>
2	<p>Select</p> <p>Go right</p>	<p><b>Select the tab.</b></p>
3	<p>Select</p> <p>Register</p>	<p><b>Select the item.</b></p>
4	<p>Select</p> <p>Register</p>	<p><b>Make the settings.</b></p>
5	<p>RETURN</p>	<p><b>Press repeatedly to exit.</b></p>

QUICK SETUP enables successive settings of the items in the shaded area.

## ■ “Disc” tab

<p><b>Audio</b> Choose the audio language.</p>	<p>• <u>English</u>    • French    • Spanish    • Original<sup>#1</sup>    • Other*<sup>#2</sup></p>
<p><b>Subtitle</b> Choose the subtitle language.</p>	<p>• <u>Automatic</u><sup>#3</sup>    • English    • French    • Spanish    • Other*<sup>#2</sup></p>
<p><b>Menus</b> Choose the language for disc menus. Changing the menu language in QUICK SETUP also changes this setting.</p>	<p>• <u>English</u>    • French    • Spanish    • Other*<sup>#2</sup></p>
<p><b>Advanced Disc Review</b> (→ page 21)</p>	<p>• <b>Intro Mode:</b> Reviews each title/program. • <b>Interval Mode:</b> Reviews not only each title/program but also each 10-minute interval within a title/program.</p>
<p><b>Ratings</b> Set a rating level to limit DVD-Video play.</p>	<p>Setting ratings (When level 8 is selected) • <u>8 No Limit</u>    • 1 to 7    • 0 Lock All: To prevent play of discs without rating levels.</p> <p>When you select your ratings level, a password screen is shown. Follow the on-screen instructions. <b>Do not forget your password.</b> A message screen will be shown if a DVD-Video disc exceeding the rating level is inserted in the unit. Enter your password and then follow the on-screen instructions.</p>

<sup>#1</sup> The original language designated on the disc is selected.

<sup>#2</sup> Input the appropriate code from the language code list (→ page 25).



<sup>#3</sup> If the language selected for “Audio” is not available, subtitles appear in that language (if available on the disc).



# Changing the player settings

QUICK SETUP enables successive settings of the items in the shaded area.

## ■ “Video” tab

<b>TV Aspect</b> Choose the setting to suit your television and preference.	<ul style="list-style-type: none"> <li>● <b>4:3 Pan&amp;Scan:</b> Regular aspect television (4:3) The sides of the widescreen picture are cut off so it fills the screen (unless prohibited by the disc). </li> </ul>
	<ul style="list-style-type: none"> <li>● <b>4:3 Letterbox:</b> Regular aspect television (4:3) Widescreen picture is shown in the letterbox style. </li> </ul>
	<ul style="list-style-type: none"> <li>● <b>16:9:</b> Widescreen television (16:9)</li> </ul>
<b>TV Type</b> Select to suit the type of television.	<ul style="list-style-type: none"> <li>● <b>Standard (Direct View TV)</b>      ● CRT Projector      ● LCD TV/Projector</li> <li>● Projection TV      ● Plasma TV</li> </ul>
<b>Time Delay</b> When connected with a Plasma display, adjust if you notice the audio is out of sync with the video.	<ul style="list-style-type: none"> <li>● <u>0ms</u>      ● 20ms      ● 40ms      ● 60ms      ● 80ms      ● 100ms</li> </ul>
<b>Still Mode</b> Specify the type of picture shown when paused.	<ul style="list-style-type: none"> <li>● <b>Automatic</b></li> <li>● <b>Field*:</b> The picture is not blurred, but picture quality is lower.</li> <li>● <b>Frame*:</b> Overall quality is high, but the picture may appear blurred.</li> </ul>
<b>Black Level Control</b> Change the black level of the picture if you connected a television through the COMPONENT VIDEO OUT terminals.	<ul style="list-style-type: none"> <li>● <b>Lighter:</b> When connected through VIDEO OUT or S-VIDEO OUT.</li> <li>● <b>Darker:</b> When connected through COMPONENT VIDEO OUT (Y/P<sub>B</sub>/P<sub>R</sub>).</li> </ul>

\* Refer to “Frame still and field still” (→ page 13, Glossary).

## ■ “Audio” tab

<b>Dynamic Range Compression</b>	<ul style="list-style-type: none"> <li>● <b>Off</b></li> <li>● <b>On:</b> Adjusts for clarity even when the volume is low by compressing the range of the lowest sound level and the highest sound level. Convenient for late night viewing. (Only works with Dolby Digital)</li> </ul>
<b>Speaker Settings (→ page 25)</b> Set the delay time for your center and surround speakers.	<ul style="list-style-type: none"> <li>● <b>Center:</b> <u>0.0</u>/1.0/2.0/3.0/4.0/5.0 ms</li> <li>● <b>Surround (L/R):</b> <u>0.0</u>/5.0/10.0/15.0 ms</li> </ul>

## ■ “Display” tab

<b>Menu Language</b>	<ul style="list-style-type: none"> <li>● <b>English</b>      ● Français      ● Español</li> </ul>
<b>On-Screen Messages</b>	<ul style="list-style-type: none"> <li>● <b>On</b>      ● Off</li> </ul>

## ■ “Others” tab

<b>FL Dimmer</b> Change the brightness of the unit’s display.	<ul style="list-style-type: none"> <li>● <b>Bright</b>      ● Dim</li> <li>● <b>Auto:</b> The display is dimmed, but brightens when you perform some operations.</li> </ul>
<b>QUICK SETUP</b>	<ul style="list-style-type: none"> <li>● <b>Yes</b>      ● No</li> </ul>
<b>Re-initialize Setting</b> Return all values in the Setup menus to the default settings.	<ul style="list-style-type: none"> <li>● <b>Yes:</b> The password screen is shown if “Ratings” (→ page 23) is set. Please enter the same password. After “INIT” on the display disappears, turn the unit off and on again.</li> <li>● <b>No</b></li> </ul>



## Changing the delay time of the speakers

### (Effective when playing multi-channel audio)

(Center and surround speakers only)

For optimum listening with 5.1-channel sound, all the speakers, except for the subwoofer, should be the same distance from the seating position.

If you have to place the center or surround speakers closer to the seating position, adjust the delay time to make up for the difference.

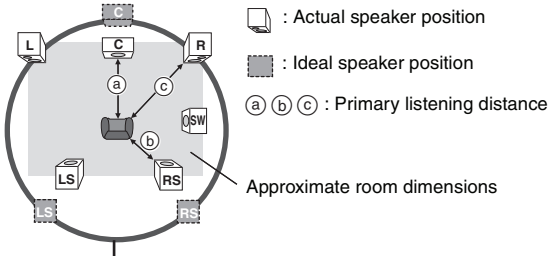

Circle of constant primary listening distance

If either distance (a) or (b) is less than (c), find the difference in the table and change to the recommended setting.

a Center speaker		b Surround speaker	
Difference (Approx.)	Setting	Difference (Approx.)	Setting
30 cm (1 foot)	1.0 ms	150 cm (5 feet)	5.0 ms
60 cm (2 feet)	2.0 ms	300 cm (10 feet)	10.0 ms
90 cm (3 feet)	3.0 ms	450 cm (15 feet)	15.0 ms
120 cm (4 feet)	4.0 ms		
150 cm (5 feet)	5.0 ms		

- 1 Press [▲, ▼] to select the delay time box and press [ENTER].
- 2 Press [▲, ▼] to adjust the delay time and press [ENTER].

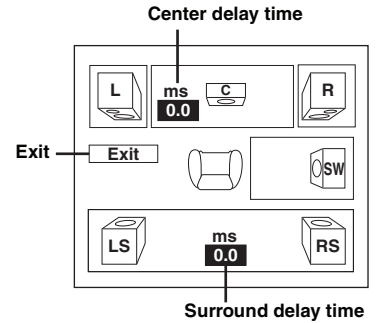

### To finish the speaker setting

Press [◀] to select "Exit" and press [ENTER].

When you change the surround speaker setting for Dolby Digital, the setting also changes for Dolby Pro Logic II.

e.g., the settings for Music are the same as those for Dolby Digital.

Dolby Digital	Dolby Pro Logic II	
	Music	Movie
0 ms	0 ms	10 ms
5 ms	5 ms	15 ms
10 ms	10 ms	20 ms
15 ms	15 ms	25 ms

## Language code list

Abkhazian: 6566	Danish: 6865	Italian: 7384	Norwegian: 7879	Swedish: 8386
Afar: 6565	Dutch: 7876	Japanese: 7465	Oriya: 7982	Tagalog: 8476
Afrikaans: 6570	English: 6978	Javanese: 7487	Pashto, Pushto: 8083	Tajik: 8471
Albanian: 8381	Esperanto: 6979	Kannada: 7578	Persian: 7065	Tamil: 8465
Ameharic: 6577	Estonian: 6984	Kashmiri: 7583	Polish: 8076	Tatar: 8484
Arabic: 6582	Faroese: 7079	Kazakh: 7575	Portuguese: 8084	Telugu: 8469
Armenian: 7289	Fiji: 7074	Kirghiz: 7589	Punjabi: 8065	Thai: 8472
Assamese: 6583	Finnish: 7073	Korean: 7579	Quechua: 8185	Tibetan: 6679
Aymara: 6589	French: 7082	Kurdish: 7585	Rhaeto-Romance: 8277	Tigrinya: 8473
Azerbaijani: 6590	Frisian: 7089	Laotian: 7679	Romanian: 8279	Tonga: 8479
Bashkir: 6665	Galician: 7176	Latin: 7665	Russian: 8285	Turkish: 8482
Basque: 6985	Georgian: 7565	Latvian, Lettish: 7686	Samoan: 8377	Turkmen: 8475
Bengali, Bangla: 6678	German: 6869	Lingala: 7678	Sanskrit: 8365	Twi: 8487
Bhutani: 6890	Greek: 6976	Lithuanian: 7684	Scots Gaelic: 7168	Ukrainian: 8575
Bihari: 6672	Greenlandic: 7576	Macedonian: 7775	Serbian: 8382	Urdu: 8582
Breton: 6682	Guarani: 7178	Malagasy: 7771	Serbo-Croatian: 8372	Uzbek: 8590
Bulgarian: 6671	Gujarati: 7185	Malay: 7783	Shona: 8378	Vietnamese: 8673
Burmese: 7789	Hausa: 7265	Malayalam: 7776	Sindhi: 8368	Volapük: 8679
Byelorussian: 6669	Hebrew: 7387	Maltese: 7784	Singhalese: 8373	Welsh: 6789
Cambodian: 7577	Hindi: 7273	Maori: 7773	Slovak: 8375	Wolof: 8779
Catalan: 6765	Hungarian: 7285	Marathi: 7782	Slovenian: 8376	Xhosa: 8872
Chinese: 9072	Icelandic: 7383	Moldavian: 7779	Somali: 8379	Yiddish: 7473
Corsican: 6779	Indonesian: 7378	Mongolian: 7778	Spanish: 6983	Yoruba: 8979
Croatian: 7282	Interlingua: 7365	Nauru: 7865	Sundanese: 8385	Zulu: 9085
Czech: 6783	Irish: 7165	Nepali: 7869	Swahili: 8387	

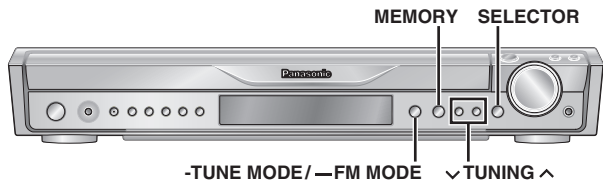
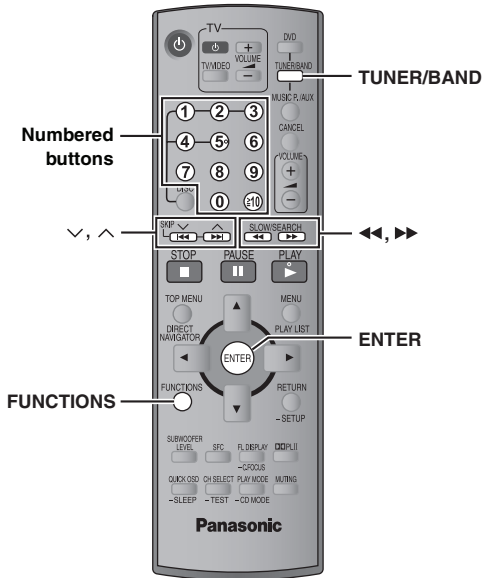

Radio operations are described mainly with the remote control. You can alternatively use the corresponding button on the main unit.

\*1 [SELECTOR]   \*2 [v TUNING ^]   \*3 [MEMORY]

## Presetting stations automatically

Up to 15 stations can be set in each band, FM and AM.

- 1 Press [TUNER/BAND]\*1 to select "FM" or "AM".
- 2 Press [◀▶]\*2 to tune to the lowest frequency (FM: 87.9 or 87.5, AM: 520).
  - When performing this step on the main unit, first press [-TUNE MODE] to select "MANUAL", and then press [v TUNING ^] to tune to the lowest frequency (FM: 87.9 or 87.5, AM: 520).
- 3 Press and hold [ENTER]\*3. Release the button when "FM AUTO" or "AM AUTO" is displayed.
 

The tuner presets all the stations it can receive into the channels in ascending order.

  - "SET OK" is displayed when the stations are set, and the radio tunes to the last preset station.
  - "ERROR" is displayed when automatic presetting is unsuccessful. Preset the channels manually (→ right).

## Selecting the preset channels

- 1 Press [TUNER/BAND]\*1 to select "FM" or "AM".
- 2 Press the numbered buttons to select the channel.
  - When selecting a 2-digit number
    - e.g. To select "12", press [≥10] → [1] → [2].

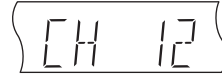

Alternatively, press [v, ^] to select the channel.

- To perform this step on the main unit, first press [-TUNE MODE] to select "PRESET", and then press [v TUNING ^] to select the channel.

When a stereo FM broadcast is being received, "ST" lights in the display.

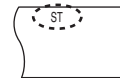

### ■ If noise is excessive

When "FM" is selected

Press and hold [—FM MODE] on the main unit to display "MONO".



Press and hold [—FM MODE] again to cancel the mode.

- The mode is also canceled when you change the frequency.

When "AM" is selected

Press [FUNCTIONS] on the remote control.

Each time you press the button: BP 2 ← BP 1

## Manual tuning

- 1 Press [TUNER/BAND]\*1 to select "FM" or "AM".
- 2 Press [◀▶]\*2 to select the frequency.
  - When performing this step on the main unit, first press [-TUNE MODE] to select "MANUAL", and then press [v TUNING ^] to select the frequency.
  - To start automatic tuning, press and hold [◀▶]\*2 until the frequency starts scrolling. Tuning stops when a station is found.

### ■ Presetting the channel

Up to 15 stations can be set in each band, FM and AM.

- ① While listening to the radio broadcast Press [ENTER]\*3.
- ② While the frequency and "PGM" are flashing on the display Press the numbered buttons to select a channel.
  - When selecting a 2-digit number
    - e.g. To select "12", press [≥10] → [1] → [2].

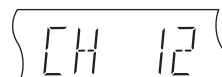

Alternatively, press [v, ^], and then press [ENTER]\*3.

The station occupying a channel is erased if another station is preset to that channel.

## ■ FM frequency step

### Main unit only

The step is factory-set to 0.2-MHz, but you can change it to receive broadcasts allocated in 0.1-MHz steps.

① Press **[SELECTOR]** to select "FM".

② Press and hold **[SELECTOR]**.

After a few seconds the display changes to show the current minimum frequency. Continue to hold the button down. The minimum frequency changes and the step is changed.

To return to the original step, repeat steps ① and ②.

#### Note

After changing the setting, previously preset frequencies will be cleared. Preset them again.

## Using an outdoor antenna (optional)

Use outdoor antennas if radio reception is poor.

- Disconnect the antenna when the unit is not in use.
- Do not use the outdoor antenna during an electrical storm.

### FM outdoor antenna [Using a television antenna (not included)]

- Disconnect the FM indoor antenna.
  - The antenna should be installed by a competent technician.
- Rework your outdoor antenna's 75 Ω coaxial cable as follows.

### AM outdoor antenna [Using a vinyl wire (not included)]

Run a piece of vinyl wire horizontally across a window or other convenient location.

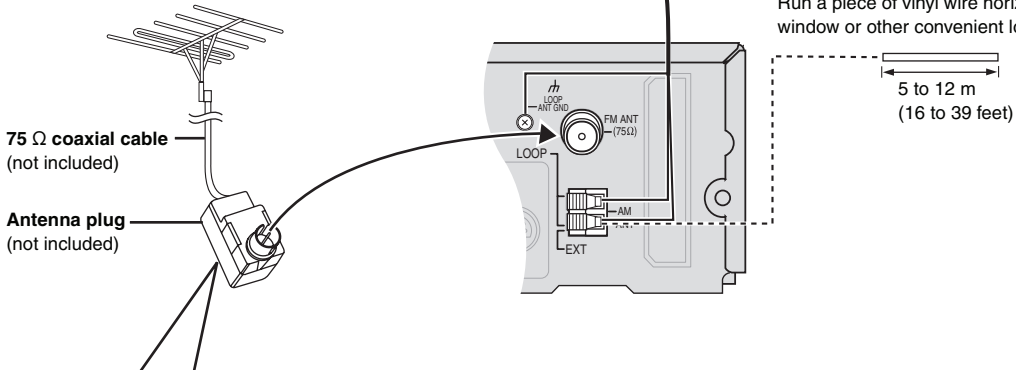

① Remove a piece of the outer vinyl insulator.

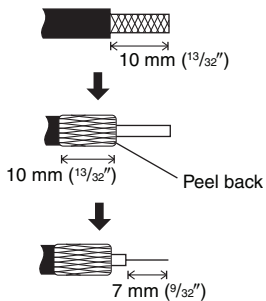

② Carefully pull the tabs apart to remove the cover.

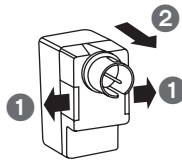

③ Install the coaxial cable.

Clamp the cable conductor, and wind it on so that it does not contact anything else.

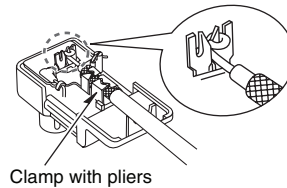

④ Attach the cover.



# Using the XM® Satellite Radio

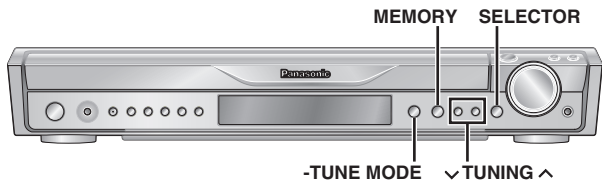
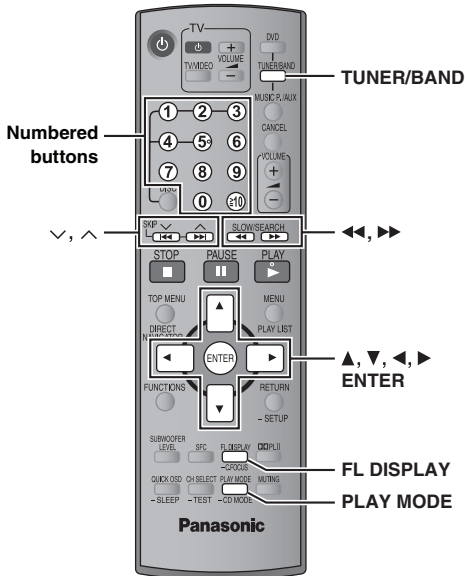

Radio operations are described mainly with the remote control. You can alternatively use the corresponding button on the main unit.

\*1 [SELECTOR] \*2 [v TUNING ^] \*3 [MEMORY] \*4 [-TUNE MODE]

## Introducing XM Satellite Radio

XM Satellite Radio is the provider of satellite radio with more than 6 million subscribers. XM offers more than 170 digital radio channels with music, talk, news, sports, comedy, traffic and weather reports. For more information, visit XM on the Web at [www.xmradio.com](http://www.xmradio.com).

## How to Subscribe

XM monthly service subscription sold separately. XM Connect & Play or XMPassport system required to receive XM service (sold separately). Installation costs and other fees and taxes, including a one-time activation fee may apply. Subscription fee is consumer only. All fees and programming subject to change. Channels with frequent explicit language are indicated with an XL. Channel blocking is available for XM radio receivers by calling 1-800-XMRADIO (1-800-967-2346). Subscriptions subject to Customer Agreement available at [xmradio.com](http://xmradio.com). XM service only available in the 48 contiguous United States. XM Ready is a trademark of XM Satellite Radio Inc. © 2006 XM Satellite Radio Inc. All rights reserved.

- To subscribe, visit XM on the Web at [www.xmradio.com](http://www.xmradio.com) or call XM's Listener Care at 1-800-XMRADIO (1-800-967-2346). You should have your Radio ID ready; the Radio ID can be found by selecting channel 0 on the radio.

## XM display examples

2	➔	2 (two)	A	➔	A	K	➔	K
5	➔	5 (five) or S	B	➔	B	M	➔	M
6	➔	6 (six)	D	➔	D	Q	➔	Q
8	➔	8 (eight)	G	➔	G	R	➔	R
0	➔	0 (zero) or O	H	➔	H	Z	➔	Z

## Displaying the XM Satellite Radio ID

You can confirm your XM Satellite Radio ID necessary for activating XM Satellite Radio as follows.

- 1 Connect the XM Connect & Play or XMPassport system (→ page 7).
- 2 Press [TUNER/BAND]\*1 to select "XM".
- 3 Press [PLAY MODE]\*4 to select "MANUAL".  
Each time you press the button: MANUAL ↔ PRESET
- 4 Press [0] to select "XM 0" (XM channel 0).  
"RADIO ID" is indicated in the display briefly, followed by an 8-digit alphanumeric ID.  
• The indications are displayed alternately.



- 5 Note your XM Satellite Radio ID here.  
• To avoid ambiguity, the letters I, O, S and F are not used in the ID.
- 
- To exit, press [◀▶]\*2 to select another channel.

## Positioning the XM Connect & Play or XMPassport system for optimal reception

The main unit has a signal strength indicator function that allows you to optimize the XM signal reception.

- 1 Press [TUNER/BAND]\*1 to select "XM".  
• Ensure the antenna is connected (→ page 7).
- 2 Press and hold [FL DISPLAY] until the XM signal status is displayed.

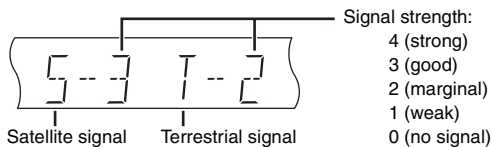

- 3 Position the antenna for the best possible satellite signal reception.  
As you position the antenna, the display changes depending on the signal strength.  
• If the satellite signal is weak or not available, you can optimize for the terrestrial signal (where available).
- 4 Press [FL DISPLAY] to return to the previous display.

## Tips for optimizing reception

- To prevent interference with wireless equipment, place the antenna away from this unit, Panasonic wireless sound system SH-FX80, Panasonic wireless system SH-FX50/SH-FX60, and other equipment that emits radio waves (such as radio equipment and microwave ovens).
- Place the antenna near a south-facing window with an unobstructed view of the sky for the best satellite signal reception.
- Refer also to the operating instructions of your XM Connect & Play or XMPassport system.

## Selecting XM channels by direct entry

XM channels can be selected manually by directly entering the XM channel number.

- 1 Press [TUNER/BAND]\*<sup>1</sup> to select "XM".
- 2 Press [PLAY MODE]\*<sup>4</sup> to select "MANUAL".  
Each time you press the button: MANUAL ↔ PRESET
- 3 Press the numbered buttons to select the XM channel.
  - When selecting a 2-digit or 3-digit number, first press [≥10] once or twice respectively, and then press the numbered buttons.  
e.g. To select "125", press [≥10] → [≥10] → [1] → [2] → [5].

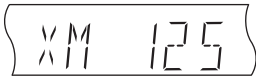

Alternatively, press [◀, ▶]\*<sup>2</sup> to select the desired XM channel.  
• Press and hold [◀, ▶]\*<sup>2</sup> to scan through quickly.

## Selecting XM channels by category

XM channels are organized into categories such as Rock, Classical, Country and Dance to make browsing and selecting broadcast content easier.

- 1 Press [TUNER/BAND]\*<sup>1</sup> to select "XM".
- 2 Press [▲, ▼, ◀, ▶] to enter category tune mode.  
"CAT ON" (CATEGORY ON) is displayed briefly, and then the category of the current XM channel flashes on the display.



- 3 While the category is flashing on the display Press [▲, ▼] to select a category.
  - Press and hold [▲, ▼] to scan through quickly.
- 4 While the selected category is flashing on the display Press [◀, ▶] to select a channel in the current category.
  - Press and hold [◀, ▶] to scan through quickly.The XM channel number and name are displayed briefly, and then the current category flashes on the display.
- 5 Press [ENTER] to exit category tune mode.  
After "CAT OFF" (CATEGORY OFF) is displayed, the XM channel number and name are displayed briefly, followed by the XM channel information.
  - The XM channel information shown depends on the display mode setting (→ right).

### Note

- Category tune mode will be canceled automatically after approximately 15 seconds if there is no user input.
- The display mode setting (→ right) cannot be changed while in category tune mode.
- The signal strength indicator function (→ page 28) cannot be activated while in category tune mode.
- XM channel selection by category enables you to narrow down your choices to channels belonging to a broadcasting category of your choice and then to select a favorite channel from the chosen category. Available categories vary according to broadcasting hours. The unit does not display categories with no broadcasting XM channel.
- Some XM channels belong to two categories; a primary and secondary category, either of which can be used for XM channel selection. Although you may have selected an XM channel from its secondary category (e.g. DANCE), after exiting and then re-entering category tune mode, the primary category of the XM channel is displayed (e.g. DECADES).

## Presetting your favorite XM channels

Channel presets allow you to quickly and conveniently select your favorite XM channels. Up to 15 XM channels can be stored as channel presets.

- 1 Select the desired XM channel.
- 2 While listening to the XM radio broadcast Press [ENTER]\*<sup>3</sup>.
- 3 While the XM channel and "PGM" are flashing on the display Press the numbered buttons to select a channel preset.
  - When selecting a 2-digit number  
e.g. To select "12", press [≥10] → [1] → [2].

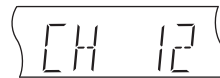

Alternatively, press [v, ^] to select the channel preset, and then press [ENTER]\*<sup>3</sup> to confirm.

- An XM channel previously stored in a channel preset is overwritten when another XM channel is stored in the same channel preset.
- XM channel 0 (RADIO ID) cannot be stored as a channel preset.

## Selecting the channel presets

- ① While listening to the XM radio broadcast Press [PLAY MODE]\*<sup>4</sup> to select "PRESET".  
Each time you press the button: MANUAL ↔ PRESET
- ② Press the numbered buttons to select the desired channel preset.
  - When selecting a 2-digit number  
e.g. To select "12", press [≥10] → [1] → [2].

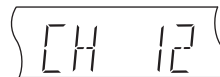

Alternatively, press [v, ^] to select the desired channel preset.

## Displaying the XM channel information

The display mode setting can be changed to display information about the broadcast content such as the category, song title or artist's name.

While listening to the XM radio broadcast Press [FL DISPLAY].

Each time you press the button:

XM channel number → XM channel name (factory preset)  
↑ ARTIST NAME ← SONG TITLE ← CATEGORY ←

- The XM channel number and name are displayed briefly whenever the XM channel is changed.
- If the text information is more than 8 characters long (SONG TITLE or ARTIST NAME only), the first 8 characters are displayed briefly, and then the remaining text is scrolled across the display (up to a total of 16 characters).

### Note

- If there is no text information for the current XM broadcast, "—" is displayed.
- For text information more than 8 characters long (SONG TITLE or ARTIST NAME only), after the text has scrolled, press [FL DISPLAY] to scroll the text again. Press [FL DISPLAY] while the text is scrolling to change the display mode.
- Whenever the main unit is turned off, or another source is selected, the display mode is reset to the factory preset (XM channel name).



# Using sound effects

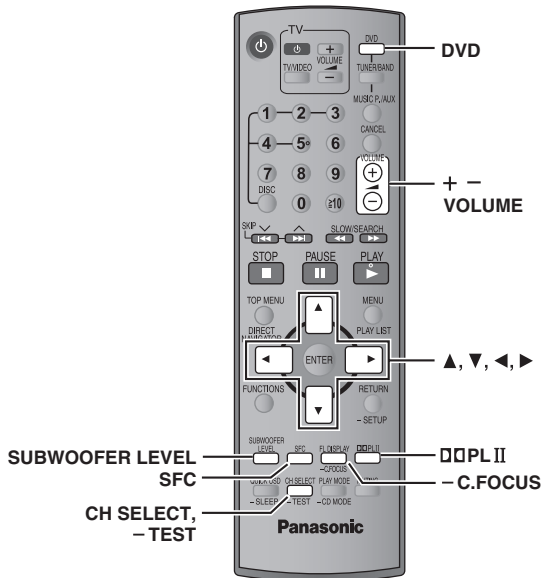

Using sound effects

## Note

- When connected with headphones or the Rear Music Port (→ page 32), Surround Music and the following sound effects may not be available or have no effect. (Excluding Sound Field Control: HEAVY, CLEAR or SOFT)
- You may experience a reduction in sound quality when these sound effects are used with some sources. If this occurs, turn the sound effects off.
- If you turn on Dolby Pro Logic II, Sound Field Control (MOVIE, SPORT or MUSIC) is canceled.

## Changing the sound quality: Sound Field Control

SFC

To enjoy the following sound quality settings, ensure that Surround Music (→ page 14) is turned off.

### Press [SFC].

#### Each time you press the button:

- FLAT:** Cancel (no effect is added) (factory preset).
- MOVIE:** Use this mode when playing movie software.
- SPORT:** Simulates sound to make you feel like you are at a sports event.
- MUSIC:** Adds surround effects to stereo sources.
- HEAVY:** Adds punch to rock.
- CLEAR:** Clarifies higher sounds.
- SOFT:** For background music.

- To check the current setting, press [SFC].
- MOVIE, SPORT and MUSIC are not available when Dolby Pro Logic II is on, or when playing a disc recorded with a multi-channel source.
- You can adjust the volume of the surround speakers to get the best surround effect (→ page 31, Adjusting the volume of each speaker: Speaker level adjustments).

## Enhancing the sound from the center speaker: Center Focus

-C.FOCUS

This applies to discs where the dialogue is recorded in the center channel.

You can make the sound of the center speaker seem like it is coming from within the television.

### Press and hold [-C.FOCUS].

#### Each time you press and hold the button:

C FOCUS ON → C FOCUS OFF

- This does not work when Surround Music (→ page 14) or Sound Field Control (MOVIE, SPORT or MUSIC) is turned on.
- This also works when Dolby Pro Logic II is turned on.

## Enhancing the stereo sound: Dolby Pro Logic II

DOLBY II

Dolby Pro Logic II is an advanced decoder that derives 5-channel surround (Left and Right Front, Center, Left and Right Surround) from stereo sound sources, whether or not it has been specifically Dolby Surround encoded.

### Press [DOLBY II].

#### Each time you press the button:

**Movie:** Movie software, recorded in Dolby Surround.

**Music:** Stereo sources

**Off:** Cancel

- This works only in DVD/CD mode.
- "DOLBY II" lights when there is effect.
- Dolby Pro Logic II is canceled when Surround Music is turned on.



## Adjusting the amount of bass: Subwoofer level

SUBWOOFER LEVEL

You can adjust the amount of bass. The unit automatically selects the most suitable setting according to the type of playing source.

### Press [SUBWOOFER LEVEL].

• [DVD-V] [DVD-VR]

SUB W 4 (factory preset)\* → SUB W 1 → SUB W 2 → SUB W 3

#### • When another source is selected

SUB W 2 (factory preset)\* → SUB W 3 → SUB W 4 → SUB W 1

- To check the current setting, press [SUBWOOFER LEVEL].
- The setting you make is retained, and recalled every time you play the same type of source, except when Sound Field Control (MOVIE, SPORT or MUSIC) is turned on.

\* When Sound Field Control (MOVIE, SPORT or MUSIC) is on, the factory presets are as follows:

- MOVIE: SUB W 4
- SPORT: SUB W 2
- MUSIC: SUB W 1

## Adjusting the volume of each speaker: Speaker level adjustments



This is one of the ways to get appropriate surround effects.

### Preparation

Press [DVD].

- 1 While stopped and no on-screen display is shown  
**Press and hold [—TEST] to output a test signal.**
  - To stop the test signal, press and hold [—TEST] again.

L: Front left                      C: Center                      R: Front right  
 RS: Right surround            LS: Left surround

  - There is no output from SW (subwoofer) channel.
- 2 Press [VOLUME, +] or [—] to set the volume level normally used for listening.
- 3 Press [▲] (increase) or [▼] (decrease) to adjust the speaker level for each speaker.
  - Adjust the speaker levels to the same level as the front speakers.

C, RS, LS: -6 dB to +6 dB

### ■ To adjust speaker level during play

[Effective when playing multi-channel audio or when Dolby Pro Logic II or Sound Field Control (MOVIE, SPORT or MUSIC) is on, and Surround Music is off.]

- ① Press [CH SELECT] to select the speaker.  
 L → C → R → RS → LS → SW  
 ↑  
 SW: Subwoofer
  - You can adjust SW only if the disc includes a subwoofer channel.
  - "SW" does not appear on the display and is not adjustable when "DOLBI" is lit.
  - "S" appears on the display when "MOVIE", "SPORT" or "MUSIC" is selected with Sound Field Control (→ page 30). In this case, you can adjust both surround speaker levels at the same time using [▲, ▼].

S: -6 dB to +6 dB
- ② Press [▲] (increase) or [▼] (decrease) to adjust the speaker level for each speaker.  
 C, RS, LS, SW: -6 dB to +6 dB  
 (L, R: Only the balance is adjustable.)
  - To adjust the balance of the front speakers, while "L" or "R" is selected, press [◀, ▶].

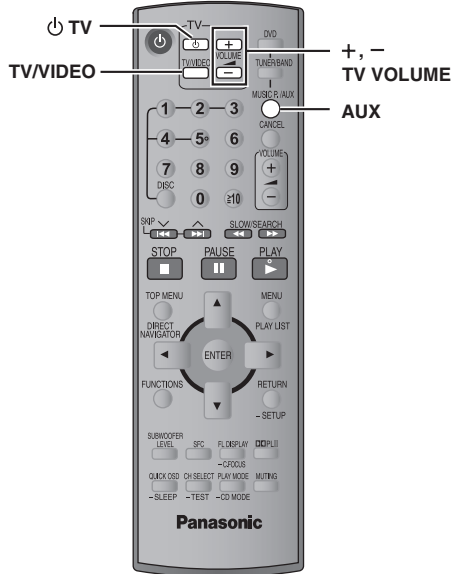

You can use the remote control to operate a Panasonic television. Connect your equipment referring to "Cable TV box or video cassette recorder connection" (→ page 9).

### Note

The remote control may not work properly with some models.

## Operating the television

Aim the remote control at the television.

### Turning the television on/off

Press [TV].

### Switching the television's video input mode

Press [TV/VIDEO].

### Adjusting the volume

Press [+ , - TV VOLUME].

### To play audio from your television through your home theater system

Select "AUX" as the source, reduce the volume on the television to its minimum, and control the volume on the main unit.



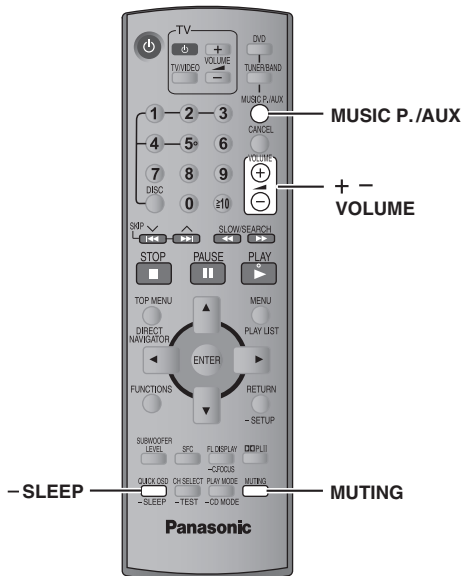

## Setting the sleep timer

-SLEEP

- 1 Press and hold [-SLEEP].

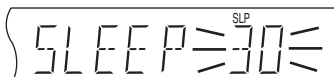

- 2 While the time is shown Press [-SLEEP] to select the time (in minutes).

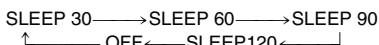

### To cancel the timer

While the time is shown, press [-SLEEP] to select "OFF".

### To confirm the remaining time

Press and hold [-SLEEP] again.

### To change the setting

Repeat the procedure from the beginning.

## Muting the sound

MUTING

Press [MUTING].

"MUTING" flashes on the unit's display.



### To cancel

- Press [MUTING] again or reduce the volume to minimum "VOL 0", and then raise it to the required level.
- Muting is canceled when you switch the unit to standby.

## Using headphones

### Main unit only

- 1 Reduce the volume and connect the headphones (not included).

Headphone plug type:  $\varnothing 3.5$  mm ( $1/8$ " stereo mini plug



- 2 Adjust headphone volume with [VOLUME].

• Audio is automatically switched to 2-channel stereo.

### Note

To prevent hearing damage, avoid listening for prolonged periods of time.

## Using the Music Port

The Music Port allows you to connect and enjoy music from an external device (e.g. MP3 player) through your home theater system.

### Preparation

To avoid distorted sound, make sure that any equalizer function of your external device is turned off.

- 1 Reduce the volume and connect the external device (not included).

Plug type:  $\varnothing 3.5$  mm ( $1/8$ " stereo mini plug

### When using the front MUSIC PORT

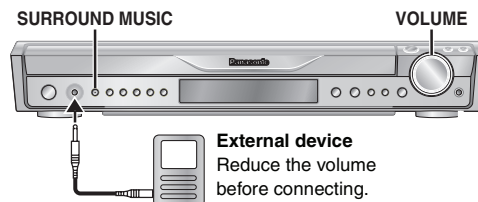

### When using the rear MUSIC PORT

External device  
Reduce the volume  
before connecting.

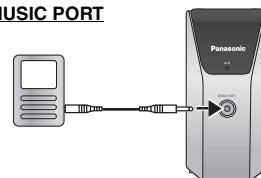

- 2 Press [MUSIC P./AUX] to select "FRONT MUSIC P." or "REAR MUSIC P."

FRONT MUSIC P. → REAR MUSIC P. → AUX



\* "REAR MUSIC P." can be selected only when the digital transceiver card is inserted into the main unit (→ page 7).

- 3 Adjust the external device volume to a normal listening level, and then adjust the volume of the main unit with [VOLUME].

• You can enjoy surround sound when you press [SURROUND MUSIC] on the main unit (except when "REAR MUSIC P." is selected).



# Troubleshooting guide

Before requesting service, make the following checks. If you are in doubt about some of the check points, or if the solutions indicated in the table do not solve the problem, refer to "Customer Services Directory" on page 38.

Power		Page
No power.	● Insert the AC power supply cord securely.	9
The unit is automatically switched to standby mode.	● The Sleep timer was working and had reached the set time limit.	32

## Unresponsive or inoperable function

No response when any buttons are pressed.	<ul style="list-style-type: none"> <li>● This unit cannot play discs other than the ones listed in these operating instructions.</li> <li>● The unit may not be operating properly due to lightning, static electricity or some other external factor. Turn the unit off and then back on. Alternatively, turn the unit off, disconnect the AC power supply cord, and then reconnect it.</li> <li>● Condensation has formed. Wait 1 to 2 hours for it to evaporate.</li> </ul>	12 —
No response when remote control buttons are pressed.	<ul style="list-style-type: none"> <li>● Check that the batteries are installed correctly.</li> <li>● The batteries are depleted. Replace them with new ones.</li> <li>● Aim the remote control at the display and operate.</li> </ul>	10 10 11
Cannot play DVDs.	● CD Mode is on. Press and hold [—CD MODE] to turn CD Mode off.	16
No picture or sound.	<ul style="list-style-type: none"> <li>● Check the video or speaker connection.</li> <li>● Check the power or input setting of the connected equipment.</li> <li>● Check that the disc has something recorded on it.</li> </ul>	6, 8 — —
You have forgotten your ratings password. Reset all the settings to Factory Preset.	● While stopped and "DVD/CD" is the source, press and hold [■] (Stop) on the main unit and [≥10] on the remote control until "Initialized" disappears from the television. Turn the unit off and on again. All settings will return to the default values.	—

## Specific operation undesirable or unexpected

It takes time before play starts. [MP3]	● Play may take time to begin when an MP3 track has still picture data. Even after the track starts, the correct play time will not be displayed. This is normal.	—
Folders on a data CD are not displayed correctly. [WMA] [MP3] [JPEG]	● Folders deeper than the eighth layer are displayed as the eighth layer.	—
A menu screen appears during skip or search. [VCD]	● This is normal for Video CDs.	—
Playback control menu does not appear. [VCD] with playback control	● Press [■ STOP] twice and then press [▶ PLAY].	—
Program and Random play do not work. [DVD-V]	● These functions do not work with some DVD-Videos.	—
Selecting audio soundtrack "2" does not change the audio. [DVD-A]	● Even if a second soundtrack is not recorded, two numbers are normally shown.	—
Play restarts from the beginning when the soundtrack is changed. [DVD-A]	● This is normal for DVD-Audio.	—
Scenes are skipped intermittently. [DVD-VR] [DVD-V]	● If you change the volume or sound effects during Advanced Disc Review, the function continues without the on-screen display. Cancel the function.	21

## Subtitle

Subtitle position is wrong.	● Adjust the position. ("Subtitle Position" in Display Menu)	22
No subtitles.	● Display the subtitles. ("Subtitle" in Main menu)	20
Subtitles overlap the closed captions.	● Clear the subtitles.	20

## Marker

Cannot add markers.	<ul style="list-style-type: none"> <li>● You cannot add markers with DVD-RAM.</li> <li>● If the disc's elapsed play time does not appear on the unit's display, you cannot add markers.</li> </ul>	— —
---------------------	--	--------

## A-B repeat

Point B is automatically set.	● The end of an item becomes point B when it is reached.	—
-------------------------------	--	---

## Sound abnormal or improper

Sound is distorted.	● Noise may occur when playing WMA.	—
Effects do not work.	● Some audio effects do not work or have less effect with some discs.	—
Humming is heard during play.	● An AC power supply cord or fluorescent light is near the main unit or wireless system. Keep other appliances and cables away from the main unit and wireless system.	—
No sound	● There may be a slight pause in sound when you change the play speed.	—

## Menus

The Setup menu cannot be accessed.	<ul style="list-style-type: none"> <li>● Select "DVD/CD" as the source.</li> <li>● Cancel Program and Random play.</li> </ul>	— 17
------------------------------------	---	---------



## Picture abnormal or unviewable

		Page
The picture on the television is not displayed correctly or disappears.	<ul style="list-style-type: none"> <li>Ensure that the unit is connected directly to the television, and is not connected through a video cassette recorder.</li> <li>Mobile telephone chargers can cause some disturbance.</li> <li>If you are using an indoor television, change to an outdoor antenna.</li> <li>The television antenna wire is too close to the unit. Move it away from the unit.</li> </ul>	8 — — —
Picture size does not fit the screen.	<ul style="list-style-type: none"> <li>Change "TV Aspect" in the "Video" tab.</li> </ul>	24
	<ul style="list-style-type: none"> <li>Use the television to change the aspect. If your television does not have that function, change "4:3 Aspect" in Display Menu.</li> </ul>	22
	<ul style="list-style-type: none"> <li>Change the zoom setting. ("Just Fit Zoom" or "Manual Zoom" in Display Menu)</li> </ul>	22
Menu is not displayed correctly.	<ul style="list-style-type: none"> <li>Restore the zoom ratio to "×1.00". ("Manual Zoom" in Display Menu)</li> </ul>	22
	<ul style="list-style-type: none"> <li>Set "Subtitle Position" in Display Menu to "0".</li> </ul>	22
	<ul style="list-style-type: none"> <li>Set "4:3 Aspect" in Display Menu to "Normal".</li> </ul>	22
Auto zoom function does not work well.	<ul style="list-style-type: none"> <li>Turn off television's zoom function.</li> </ul>	—
	<ul style="list-style-type: none"> <li>Use the other preset aspect ratios or manual adjustment.</li> </ul>	22
	<ul style="list-style-type: none"> <li>Zoom function may not work well, especially in dark scenes and may not work depending on the type of disc.</li> </ul>	—

## Progressive video

There is ghosting when progressive is on.	<ul style="list-style-type: none"> <li>This problem is caused by the editing method or material used on DVD-Video, but should be corrected if you use interlaced output. Set "Video Output Mode" in Picture Menu to "480i". (Alternatively, press and hold [CANCEL] to switch to "480i".)</li> </ul>	21
Pictures not in progressive output.	<ul style="list-style-type: none"> <li>Select "480p" in "Video Output Mode" in Picture Menu.</li> </ul>	21
	<ul style="list-style-type: none"> <li>The unit's VIDEO OUT or S-VIDEO OUT terminal outputs the interlaced signal even if "PRG" is displayed.</li> </ul>	8
Closed captions not displayed.	<ul style="list-style-type: none"> <li>When progressive output is on, closed captions will not be displayed.</li> </ul>	—

## Listening to the radio

Distorted sound or noise is heard. "ST" flickers or does not light.	<ul style="list-style-type: none"> <li>Adjust the position of the FM or AM antenna.</li> </ul>	—
	<ul style="list-style-type: none"> <li>Use an outdoor antenna.</li> </ul>	27
A beat sound is heard.	<ul style="list-style-type: none"> <li>Turn the television off or move it away from the unit.</li> </ul>	—
A low hum is heard during AM broadcasts.	<ul style="list-style-type: none"> <li>Separate the antenna from other cables.</li> </ul>	—

## Wireless system

No sound.	<ul style="list-style-type: none"> <li>Ensure that the digital transceiver is fully inserted into the slot of the main unit.</li> </ul>	7
	<ul style="list-style-type: none"> <li>Ensure that the wireless system is plugged into the AC outlet, and "[W]" is displayed on the main unit's display.</li> </ul>	9
Sound is mixed.	<ul style="list-style-type: none"> <li>When the selected source on the main unit is not "REAR MUSIC P.", audio from an external device connected to the rear MUSIC PORT is mixed with audio from the main unit (e.g. listening to music from an MP3 player while playing a DVD). Select "REAR MUSIC P." as the source. Alternatively, disconnect the external device.</li> </ul>	11, 32

## Unit displays

The display is dark.	<ul style="list-style-type: none"> <li>Select "Bright" in "FL Dimmer" in the "Others" tab.</li> </ul>	24
"NOPLAY"	<ul style="list-style-type: none"> <li>You inserted a disc the unit cannot play; insert one it can.</li> <li>You inserted a blank disc.</li> <li>You inserted a disc that has not been finalized.</li> </ul>	12 — —
"NODISC"	<ul style="list-style-type: none"> <li>You have not inserted a disc; insert one.</li> </ul>	—
	<ul style="list-style-type: none"> <li>You have not inserted the disc correctly; insert it correctly.</li> </ul>	14
"F61"	<ul style="list-style-type: none"> <li>Check and correct the speaker cable connections. If this does not fix the problem, consult the dealer.</li> </ul>	6
"DVD U11"	<ul style="list-style-type: none"> <li>Disc may be dirty. Wipe it clean.</li> </ul>	12
"ERROR"	<ul style="list-style-type: none"> <li>Incorrect operation performed. Read the instructions and try again.</li> </ul>	—
"DVD H□□" □□ stands for a number.	<ul style="list-style-type: none"> <li>Trouble may have occurred. The number following "H" depends on the status of the unit. Turn the unit off and then back on. Alternatively, turn the unit off, disconnect the AC power supply cord, and then reconnect it.</li> <li>If the service numbers fail to clear, note the service number and contact a qualified service person.</li> </ul>	— —
"[W]" is flashing. (When using the wireless system and digital transceiver)	<ul style="list-style-type: none"> <li>There is no link between the main unit and the wireless system. Check that the wireless system is plugged into the AC outlet.</li> <li>Ensure that the digital transceiver is fully inserted into the slot of the main unit.</li> </ul>	— —
"D.MIX" is flashing. [DVD-A]	<ul style="list-style-type: none"> <li>Down-mixing is the process of remixing the multiple-channel audio found on some discs into two channels. The disc contains single-channel or multiple-channel signals which may not be reproduced authentically.</li> </ul>	—
"XM RADIO"	<ul style="list-style-type: none"> <li>It takes a short time for the XM radio to power up after turning on the main unit, during which time "XM RADIO" is displayed (only when the selected source is XM). Wait a few seconds for this process to complete.</li> </ul>	—
"XM ERROR"	<ul style="list-style-type: none"> <li>An error in the XM radio module has been detected. Turn the main unit off, and then back on to clear the error.</li> </ul>	—
	<ul style="list-style-type: none"> <li>If the error message persists, the XM radio module may need repair. For repair work, refer to "Customer Services Directory" in the limited warranty section of this manual.</li> </ul>	38



## Television displays

Page

“⊘”	<ul style="list-style-type: none"> <li>The operation is prohibited by the unit or disc.</li> </ul>	—
“Cannot display group xx, content xx”	<ul style="list-style-type: none"> <li>You are trying to display incompatible contents.</li> </ul>	—
“This disc may not be played in your region”	<ul style="list-style-type: none"> <li>Only DVD-Video discs that include or have the same region number as the one on the rear panel of this unit can be played.</li> </ul>	Cover page
No on-screen display.	<ul style="list-style-type: none"> <li>Select “On” in “On-Screen Messages” in the “Display” tab.</li> </ul>	24

## XM Satellite Radio advisory messages

“ANTENNA” is flashing.	<ul style="list-style-type: none"> <li>The XM Connect &amp; Play or XMPassport system is not properly connected. Check the connection and make sure the antenna cable is not damaged.</li> </ul>	7
“UPDATING” is flashing.	<ul style="list-style-type: none"> <li>The XM Connect &amp; Play or XMPassport system is being updated with the latest encryption code. Wait a few seconds for the update to complete.</li> <li>You may have selected an XM channel that has been blocked, or is no longer available with your subscription package. If you want to inquire about receiving the channel, call XM’s Listener Care at 1-800-XMRADIO (1-800-967-2346).</li> </ul>	—
“NO SIGNAL” is flashing.	<ul style="list-style-type: none"> <li>The XM signal is too weak. Reorient the XM Connect &amp; Play or XMPassport system for better reception.</li> </ul>	28
“LOADING” is flashing.	<ul style="list-style-type: none"> <li>The XM Connect &amp; Play or XMPassport system is receiving and decoding the broadcast information. Wait a few seconds for loading to complete.</li> </ul>	—
“OFF AIR” is flashing.	<ul style="list-style-type: none"> <li>The selected XM channel is not currently broadcasting. Select a different channel.</li> </ul>	29
“XM ———” is displayed.	<ul style="list-style-type: none"> <li>The selected XM channel is not available. Select a different channel.</li> </ul>	29
“———” is displayed.	<ul style="list-style-type: none"> <li>Supplemental text information, such as the song title or artist’s name is not available for that particular broadcast. You can change the type of XM channel information that is displayed by pressing [FL DISPLAY].</li> </ul>	29
You can receive only promotional XM channels	<ul style="list-style-type: none"> <li>Your XM Connect &amp; Play or XMPassport system has not been activated, or your subscription has expired. To activate your XM Connect &amp; Play or XMPassport system, or to renew your subscription, visit XM on the Web at <a href="http://www.xmradio.com">www.xmradio.com</a> or call XM’s Listener Care at 1-800-XMRADIO (1-800-967-2346). You should have your Radio ID ready.</li> </ul>	28



## AMPLIFIER SECTION

### RMS Output Power: Dolby Digital Mode

Front Ch	110 W per channel (3 Ω), 1 kHz, 10 % THD
Surround Ch	90 W per channel (4 Ω), 1 kHz, 10 % THD
Center Ch	225 W per channel (6 Ω), 1 kHz, 10 % THD
Subwoofer Ch	225 W per channel (6 Ω), 100 Hz, 10 % THD
Total RMS Dolby Digital mode power	850 W

### FTC Output Power: Dolby Digital Mode

Front Ch	40 W per channel (3 Ω), 120 Hz–20 kHz, 1 % THD
Surround Ch	70 W per channel (4 Ω), 120 Hz–20 kHz, 1 % THD
Center Ch	75 W per channel (6 Ω), 120 Hz–20 kHz, 1 % THD
Subwoofer Ch	65 W per channel (6 Ω), 45 Hz–120 Hz, 1 % THD
Total FTC Dolby Digital mode power	360 W

## FM/AM TUNER, TERMINALS SECTION

<b>Preset Memory</b>	FM 15 stations AM/MW 15 stations
----------------------	-------------------------------------

### Frequency Modulation (FM)

Frequency range	87.9–107.9 MHz (200-kHz step) 87.5–108.0 MHz (100-kHz step)
Sensitivity	2.5 μV (IHF)
S/N 26 dB	2.2 μV
Antenna terminals	75 Ω (unbalanced)

### Amplitude Modulation (AM/MW)

Frequency range	520–1710 kHz (10-kHz step)
AM Sensitivity S/N 20 dB at 1000 kHz	560 μV/m

### Phone jack

Terminal	Stereo, 3.5 mm (1/8") jack
----------	----------------------------

### Music Port (Front)

Sensitivity	100 mV, 4.7 kΩ
Terminal	Stereo, 3.5 mm (1/8") jack

## DISC SECTION

### Discs played [8 cm (3") or 12 cm (5")]

- (1) DVD (DVD-Video, DVD-Audio)
- (2) DVD-RAM (DVD-VR, JPEG<sup>®4,5</sup>)
- (3) DVD-R (DVD-Video)
- (4) DVD-RW (DVD-Video)
- (5) +R/+RW (Video)
- (6) CD, CD-R/RW [CD-DA, Video CD, SVCD<sup>®1</sup>, MP3<sup>®2,5</sup>, WMA<sup>®3,5</sup>, JPEG<sup>®4,5</sup>, HighMAT Level 2 (Audio and Image)]

<sup>®1</sup> Conforming to IEC62107

<sup>®2</sup> MPEG-1 Layer 3, MPEG-2 Layer 3

<sup>®3</sup> Windows Media Audio Ver.9.0 Class 2A

Not compatible with Multiple Bit Rate (MBR)

<sup>®4</sup> Exif Ver 2.1 JPEG Baseline files

Picture resolution: between 320×240 and 6144×4096 pixels (Sub sampling is 4:2:2 or 4:2:0). Extremely long and narrow pictures may not be displayed.

<sup>®5</sup> The total combined maximum number of recognizable audio and picture contents and groups: 4000 audio and picture contents and 400 groups.

### Pick up

Wavelength (DVD/CD)	662/785 nm
Laser power (DVD/CD)	CLASS II/CLASS I

### Audio output (Disc)

Number of channels	5.1ch (FL, FR, C, SL, SR, SW)
--------------------	-------------------------------

## VIDEO SECTION

<b>Video system</b>	NTSC
---------------------	------

### Composite video output

Output level	1 Vp-p (75 Ω)
Terminal	Pin jack (1 system)

### S-video output

Y output level	1 Vp-p (75 Ω)
C output level	NTSC; 0.286 Vp-p (75 Ω)
Terminal	S terminal (1 system)

### Component video output (480p/480i)

Y output level	1 Vp-p (75 Ω)
P <sub>B</sub> output level	0.7 Vp-p (75 Ω)
P <sub>R</sub> output level	0.7 Vp-p (75 Ω)
Terminal	Pin jack (Y: green, P <sub>B</sub> : blue, P <sub>R</sub> : red) (1 system)



## SPEAKER SECTION

### Front speakers SB-FS440

<b>Type</b>	1 way, 1 speaker system (Bass reflex)
<b>Speaker unit(s)</b>	Impedance 3 Ω
Full range	6.5 cm (2 <sup>1</sup> / <sub>2</sub> " ) Cone type
<b>Input power (IEC)</b>	110 W <sup>*6</sup> (Max)
<b>Output sound pressure</b>	80 dB/W (1.0 m)
<b>Frequency range</b>	102 Hz–25 kHz (–16 dB) 113 Hz–22 kHz (–10 dB)
<b>Dimensions (W×H×D)</b>	92 mm×273 mm×95.4 mm (3 <sup>5</sup> / <sub>8</sub> "×10 <sup>3</sup> / <sub>4</sub> "×3 <sup>3</sup> / <sub>4</sub> " )
<b>Mass</b>	0.84 kg (1.85 lbs)

### Surround speakers SB-FS441

<b>Type</b>	1 way, 1 speaker system (Bass reflex)
<b>Speaker unit(s)</b>	Impedance 4 Ω
Full range	6.5 cm (2 <sup>1</sup> / <sub>2</sub> " ) Cone type
<b>Input power (IEC)</b>	90 W <sup>*6</sup> (Max)
<b>Output sound pressure</b>	80 dB/W (1.0 m)
<b>Frequency range</b>	96 Hz–25 kHz (–16 dB) 120 Hz–22 kHz (–10 dB)
<b>Dimensions (W×H×D)</b>	92 mm×135 mm×95.4 mm (3 <sup>5</sup> / <sub>8</sub> "×5 <sup>3</sup> / <sub>8</sub> "×3 <sup>3</sup> / <sub>4</sub> " )
<b>Mass</b>	0.75 kg (1.65 lbs)

### Center speaker SB-PC640

<b>Type</b>	1 way, 2 speaker system (Bass reflex)
<b>Speaker unit(s)</b>	Impedance 6 Ω
1. Full range	6.5 cm (2 <sup>1</sup> / <sub>2</sub> " ) Cone type
2. Full range	6.5 cm (2 <sup>1</sup> / <sub>2</sub> " ) Cone type
<b>Input power (IEC)</b>	250 W <sup>*6</sup> (Max)
<b>Output sound pressure</b>	84 dB/W (1.0 m)
<b>Frequency range</b>	105 Hz–25 kHz (–16 dB) 125 Hz–22 kHz (–10 dB)
<b>Dimensions (W×H×D)</b>	270 mm×92 mm×95.4 mm (10 <sup>5</sup> / <sub>8</sub> "×3 <sup>5</sup> / <sub>8</sub> "×3 <sup>3</sup> / <sub>4</sub> " )
<b>Mass</b>	1.3 kg (2.9 lbs)

### Subwoofer SB-W440

<b>Type</b>	1 way, 1 speaker system (Bass reflex)
<b>Speaker unit(s)</b>	Impedance 6 Ω
Woofer	16 cm (6 <sup>1</sup> / <sub>2</sub> " ) Cone type
<b>Input power (IEC)</b>	250 W (Max)
<b>Output sound pressure</b>	80 dB/W (1.0 m)
<b>Frequency range</b>	32 Hz–220 Hz (–16 dB) 38 Hz–180 Hz (–10 dB)
<b>Dimensions (W×H×D)</b>	183 mm×396 mm×267 mm (7 <sup>1</sup> / <sub>32</sub> "×15 <sup>19</sup> / <sub>32</sub> "×10 <sup>1</sup> / <sub>2</sub> " )
<b>Mass</b>	4 kg (8.8 lbs)

## GENERAL

<b>Power supply</b>	AC 120 V, 60 Hz
<b>Power consumption</b>	Main unit 125 W
<b>Dimensions (W×H×D)</b>	430 mm×70 mm×439.2 mm (16 <sup>15</sup> / <sub>16</sub> "×2 <sup>3</sup> / <sub>4</sub> "×17 <sup>19</sup> / <sub>64</sub> " )
<b>Mass</b>	Main unit 4.7 kg (10.36 lbs)
<b>Operating temperature range</b>	+5 °C to +35 °C (+41 °F to +95 °F)
<b>Operating humidity range</b>	5 % to 90 % RH (no condensation)

<b>Power consumption in standby mode</b>	approx. 0.5 W
--	---------------

## WIRELESS SYSTEM AND DIGITAL TRANSCEIVER

### AMPLIFIER SECTION

<b>RMS output power stereo mode</b>	Surround Ch (both ch driven) 65 W per channel (4 Ω), 1 kHz, 10 % THD	Total RMS stereo mode power 130 W
<b>FTC output power stereo mode</b>	Surround Ch (both ch driven) 40 W per channel (4 Ω), 20 Hz–20 kHz, 1 % THD	Total FTC stereo mode power 80 W

### RF SECTION

<b>Wireless module</b>	Frequency range 2.402 to 2.480 GHz
RF output power	19 dBm (Max)
RF output impedance	50 Ω
<b>Music Port (Rear)</b>	Sensitivity 100 mV
Input impedance	4.7 kΩ
Terminal	Stereo, 3.5 mm (1/8" ) jack

### GENERAL

<b>Power supply</b>	AC 120 V, 60 Hz
<b>Power consumption</b>	Digital transceiver 0.85 W
Wireless system	30 W
<b>Dimensions (W×H×D)</b>	Digital transceiver 97 mm×47.5 mm×8.5 mm (3 <sup>13</sup> / <sub>16</sub> "×1 <sup>7</sup> / <sub>8</sub> "× <sup>11</sup> / <sub>32</sub> " )
Wireless system	89 mm×189 mm×180 mm (3 <sup>1</sup> / <sub>2</sub> "×7 <sup>7</sup> / <sub>16</sub> "×7 <sup>3</sup> / <sub>32</sub> " )
<b>Mass</b>	Digital transceiver 0.03 kg (0.07 lbs)
Wireless system	0.7 kg (1.5 lbs)
<b>Operating temperature range</b>	+5 °C to +35 °C (+41 °F to +95 °F)
<b>Operating humidity range</b>	5 % to 90 % RH (no condensation)

<b>Power consumption in standby mode</b>	Transmit mode 0.5 W
	Receive mode 1.2 W

<sup>\*6</sup> Rating with low-cut filter equipped amplifier

### Note

- Specifications are subject to change without notice. Mass and dimensions are approximate.
- Total harmonic distortion is measured by a digital spectrum analyzer.



# Limited Warranty

Panasonic Consumer Electronics Company,  
Division of Panasonic Corporation of North America  
One Panasonic Way Secaucus, New Jersey 07094

Panasonic Puerto Rico, Inc.  
Ave. 65 de Infantería, Km. 9.5  
San Gabriel Industrial Park, Carolina, Puerto Rico 00985

## Panasonic Audio Products Limited Warranty

### Limited Warranty Coverage

If your product does not work properly because of a defect in materials or workmanship, Panasonic Consumer Electronics Company or Panasonic Puerto Rico, Inc. (collectively referred to as "the warrantor") will, for the length of the period indicated on the chart below, which starts with the date of original purchase ("warranty period"), at its option either (a) repair your product with new or refurbished parts, or (b) replace it with a new or a refurbished product. The decision to repair or replace will be made by the warrantor.

Product or Part Name	Parts	Labor
Audio Products (except items listed below)	One (1) year	One (1) year
USB Reader-Writer, Personal Computer Card Adapters (in exchange for defective item)	One (1) year	Not Applicable
Accessories: Headphones, Cartridges, Microphones, Adapters	Ninety (90) days	Ninety (90) days
Rechargeable Batteries, DVD-R/-RAM Discs (in exchange for defective item)	Ten (10) days	Not Applicable
SD Memory Cards, Rechargeable Battery Packs (in exchange for defective item)	Ninety (90) days	Not Applicable

During the "Labor" warranty period there will be no charge for labor. During the "Parts" warranty period, there will be no charge for parts. You must carry-in or mail-in your product during the warranty period. If non-rechargeable batteries are included, they are not warranted. This warranty only applies to products purchased and serviced in the United States or Puerto Rico. This warranty is extended only to the original purchaser of a new product which was not sold "as is". A purchase receipt or other proof of the original purchase date is required for warranty service.

### Carry-In or Mail-In Service

For Carry-In or Mail-In Service in the United States call 1-800-211-PANA (1-800-211-7262) or visit Panasonic web site: <http://www.panasonic.com>  
For assistance in Puerto Rico call Panasonic Puerto Rico, Inc. (787)-750-4300 or fax (787)-768-2910.

### Limited Warranty Limits And Exclusions

This warranty ONLY COVERS failures due to defects in materials or workmanship, and DOES NOT COVER normal wear and tear or cosmetic damage. The warranty ALSO DOES NOT COVER damages which occurred in shipment, or failures which are caused by products not supplied by the warrantor, or failures which result from accidents, misuse, abuse, neglect, mishandling, misapplication, alteration, faulty installation, set-up adjustments, misadjustment of consumer controls, improper maintenance, power line surge, lightning damage, modification, or commercial use (such as in a hotel, office, restaurant, or other business), rental use of the product, service by anyone other than a Factory Servicenter or other Authorized Servicer, or damage that is attributable to acts of God.

**THERE ARE NO EXPRESS WARRANTIES EXCEPT AS LISTED UNDER "LIMITED WARRANTY COVERAGE". THE WARRANTOR IS NOT LIABLE FOR INCIDENTAL OR CONSEQUENTIAL DAMAGES RESULTING FROM THE USE OF THIS PRODUCT, OR ARISING OUT OF ANY BREACH OF THIS WARRANTY.** (As examples, this excludes damages for lost time, travel to and from the servicer, loss of media or images, data or other memory content. The items listed are not exclusive, but are for illustration only.) **ALL EXPRESS AND IMPLIED WARRANTIES, INCLUDING THE WARRANTY OF MERCHANTABILITY, ARE LIMITED TO THE PERIOD OF THE LIMITED WARRANTY.**

Some states do not allow the exclusion or limitation of incidental or consequential damages, or limitations on how long an implied warranty lasts, so the exclusions may not apply to you. This warranty gives you specific legal rights and you may also have other rights which vary from state to state. If a problem with this product develops during or after the warranty period, you may contact your dealer or Servicenter. If the problem is not handled to your satisfaction, then write to the warrantor's Consumer Affairs Department at the addresses listed for the warrantor.

**PARTS AND SERVICE WHICH ARE NOT COVERED BY THIS LIMITED WARRANTY ARE YOUR RESPONSIBILITY.**

## Customer Services Directory

Obtain Product Information and Operating Assistance; locate your nearest Dealer or Servicenter; purchase Parts and Accessories; or make Customer Service and Literature requests by visiting our Web Site at:

<http://www.panasonic.com/consumersupport>

or, contact us via the web at:

<http://www.panasonic.com/contactinfo>

You may also contact us directly at:

1-800-211-PANA (7262),

Monday-Friday 9 am-9 pm; Saturday-Sunday 10 am-7 pm, EST.

For hearing or speech impaired TTY users, TTY : 1-877-833-8855

## Accessory Purchases

Purchase Parts, Accessories and Instruction Books online for all Panasonic Products by visiting our Web Site at:

<http://www.pasc.panasonic.com>

or, send your request by E-mail to:

[npcparts@us.panasonic.com](mailto:npcparts@us.panasonic.com)

You may also contact us directly at:

1-800-332-5368 (Phone) 1-800-237-9080 (Fax Only) (Monday – Friday 9 am to 8 pm, EST.)

Panasonic Services Company

20421 84th Avenue South, Kent, WA 98032

(We Accept Visa, MasterCard, Discover Card, American Express, and Personal Checks)

For hearing or speech impaired TTY users, TTY : 1-866-605-1277

## Service in Puerto Rico

Panasonic Puerto Rico, Inc.

Ave. 65 de Infantería, Km. 9.5, San Gabriel Industrial Park, Carolina, Puerto Rico 00985

Phone (787)750-4300, Fax (787)768-2910



**User memo:**

DATE OF PURCHASE \_\_\_\_\_

DEALER NAME \_\_\_\_\_

DEALER ADDRESS \_\_\_\_\_

TELEPHONE NUMBER \_\_\_\_\_

The model number and serial number of this product can be found on either the back or the bottom of the unit. Please note them in the space provided below and keep for future reference.

MODEL NUMBER \_\_\_\_\_ SC-HT441W \_\_\_\_\_

SERIAL NUMBER \_\_\_\_\_

## Listening caution



Selecting fine audio equipment such as the unit you've just purchased is only the start of your musical enjoyment. Now it's time to consider how you can maximize the fun and excitement your equipment offers. This manufacturer and the Electronic Industries Association's Consumer Electronics Group want you to get the most out of your equipment by playing it at a safe level. One that lets the sound come through loud and clear without annoying blaring or distortion—and, most importantly, without affecting your sensitive hearing.

We recommend that you avoid prolonged exposure to excessive noise.

Sound can be deceiving. Over time your hearing "comfort level" adapts to higher volumes of sound. So what sounds "normal" can actually be loud and harmful to your hearing.

Guard against this by setting your equipment at a safe level BEFORE your hearing adapts.

To establish a safe level:

- Start your volume control at a low setting.
- Slowly increase the sound until you can hear it comfortably and clearly, and without distortion.

Once you have established a comfortable sound level:

- Set the dial and leave it there.

Taking a minute to do this now will help to prevent hearing damage or loss in the future. After all, we want you listening for a lifetime.

Manufactured under license from Dolby Laboratories. "Dolby", "Pro Logic" and the double-D symbol are trademarks of Dolby Laboratories.

"DTS" and "DTS Digital Surround" are registered trademarks of Digital Theater Systems, Inc.

Apparatus Claims of U.S. Patent Nos. 4,631,603, 4,577,216, and 4,819,098, licensed for limited viewing uses only.

This product incorporates copyright protection technology that is protected by method claims of certain U.S. patents and other intellectual property rights owned by Macrovision Corporation and other rights owners. Use of this copyright protection technology must be authorized by Macrovision Corporation, and is intended for home and other limited viewing uses only unless otherwise authorized by Macrovision Corporation. Reverse engineering or disassembly is prohibited.

MPEG Layer-3 audio decoding technology licensed from Fraunhofer IIS and Thomson multimedia.

The XM name and related logo XM Ready are registered trademarks of XM Satellite Radio Inc. All rights reserved.

Windows Media, and the Windows logo are trademarks, or registered trademarks of Microsoft Corporation in the United States and/or other countries.



WMA is a compression format developed by Microsoft Corporation. It achieves the same sound quality as MP3 with a file size that is smaller than that of MP3.



HighMAT™ and the HighMAT logo are either trademarks or registered trademarks of Microsoft Corporation in the United States and/or other countries.

HDCD®, HDCD®, High Definition Compatible Digital® and Pacific Microsonics™ are either registered trademarks or trademarks of Pacific Microsonics, Inc. in the United States and/or other countries.

HDCD system manufactured under license from Pacific Microsonics, Inc. This product is covered by one or more of the following: In the USA: 5,479,168, 5,638,074, 5,640,161, 5,808,574, 5,838,274, 5,854,600, 5,864,311, 5,872,531, and in Australia: 669114, with other patents pending.



# Accessories



Please check and identify the supplied accessories. Use numbers indicated in parentheses when asking for replacement parts. (Product numbers correct as of June 2006. These may be subject to change.)

To order accessories, refer to "Accessory Purchases" on page 38.

- 1 Remote control  
(N2QAYZ000001)



- 1 Video cable  
(K2KA2BA00001)



- 1 FM indoor antenna  
(RSA0007-L)



- 2 Sheets of speaker cable stickers



- 2 Remote control batteries



- 1 AM loop antenna  
(N1DAAAA00002)



- 2 AC power supply cords  
(K2CB2CB00018)



## FCC Note:

This equipment has been tested and found to comply with the limits for a Class B digital device, pursuant to Part 15 of the FCC Rules. These limits are designed to provide reasonable protection against harmful interference in a residential installation. This equipment generates, uses and can radiate radio frequency energy and, if not installed and used in accordance with the instructions, may cause harmful interference to radio communications.

However, there is no guarantee that interference will not occur in a particular installation. If this equipment does cause harmful interference to radio or television reception, which can be determined by turning the equipment off and on, the user is encouraged to try to correct the interference by one or more of the following measures:

- Reorient or relocate the receiving antenna.
- Increase the separation between the equipment and receiver.
- Connect the equipment into an outlet on a circuit different from that to which the receiver is connected.
- Consult the dealer or an experienced radio/TV technician for help.

**FCC caution:** To maintain compliance with FCC regulations, shielded interface cables must be used with this equipment. Operation with non-approved equipment or unshielded cables may result in interference to radio and TV reception. Any changes or modifications not approved by the party responsible for compliance could void the user's authority to operate this equipment.

This device complies with Part 15 of the FCC Rules. Operation is subject to the following two conditions:

- (1) This device may not cause harmful interference, and
- (2) this device must accept any interference received, including interference that may cause undesired operation.

Responsible Party:  
Panasonic Corporation of North America  
One Panasonic Way  
Secaucus, NJ 07094  
Telephone No.: 1-800-211-7262



## WARNING:

To satisfy FCC RF exposure requirements for mobile transmitting devices, a separation distance of 20 cm or more should be maintained between the antenna of this device and persons during device operation. To ensure compliance, operations at closer than this distance is not recommended. The antenna used for this transmitter must not be co-located in conjunction with any other antenna or transmitter.

This device complies with Part 15 of the FCC Rules. Operation is subject to the following two conditions:

- (1) This device may not cause harmful interference,
- (2) This device must accept any interference received, including interference that may cause undesired operation.

## -If you see this symbol-

### Information on Disposal in other Countries outside the European Union



This symbol is only valid in the European Union. If you wish to discard this product, please contact your local authorities or dealer and ask for the correct method of disposal.

<b>CAUTION</b>	- LASER RADIATION WHEN OPEN. DO NOT STARE INTO BEAM.	FDA 21 CFR / Class
<b>CAUTION</b>	- CLASS 1M VISIBLE AND INVISIBLE LASER RADIATION WHEN OPEN. DO NOT VIEW DIRECTLY WITH OPTICAL INSTRUMENTS. #620825-1 4-01 Class 1M	
<b>WARNING</b>	- KLASS 1M SYNLIG OCH OSYNLIG LASERSTRÅLNING NÄR DEBÅNDEL ÄR ÖPPNAD. BETRÄKTA EJ STRÅLEN DIREKT GENOM OPTISKA INSTRUMENT.	
<b>FORSIGTIG</b>	- SYNLIG OG USYNLIG LASERSTRÅLING KLASS 1M. NÅR LASET ER ÅBENT, UDGÅ ET SE LIGE PÅ MED OPTISKE INSTRUMENTER.	
<b>VARO!</b>	- AVATTAESSA OLET ALTIIN LUKKAN 1M NÄKYVÄÄ JA NÄKYMÄTÖNTÄ. LASERSÄTELVÄ, ÄLÄ KATSO OPTISELLÄ LAITTEELLA SUORAAN SÄTEESEEN.	
<b>VORSICHT</b>	- SICHTBARE UND UNSICHTBARE LASERSTRÄHLUNG KLASSE 1M, WENN ABDECKUNG GEÖFFNET, NICHT DIREKT MIT OPTISCHEN INSTRUMENTEN BETRACHTEN.	
<b>ATTENTION</b>	- RAYONNEMENT LASER VISIBLE ET INVISIBLE, CLASSE 1M, EN CAS D'OUVERTURE. NE PAS REGARDER DIRECTEMENT À L'ŒIL DES INSTRUMENTS D'OPTIQUE.	
注意	- ここを開くと可視及び不可視レーザー光が出ます。 ご一歩を免れ、覗かれたりしないでください。	
注意	- 打开时有可见及不可见激光辐射。请勿直视辐射。 GB2441-1-20013B 类 ROLX50075	

(Inside of product)

## Panasonic Consumer Electronics Company, Division of Panasonic Corporation of North America

One Panasonic Way Secaucus,  
New Jersey 07094  
<http://www.panasonic.com>

## Panasonic Puerto Rico, Inc.

Ave. 65 de Infantería, Km. 9.5  
San Gabriel Industrial Park, Carolina,  
Puerto Rico 00985

