

## Waterproof Case Marine pack

## Boîtier étanche Caisson étanche

### Operating Instructions Mode d'emploi Manual de instrucciones

## MPK-WEB

© 2009 Sony Corporation Printed in Japan

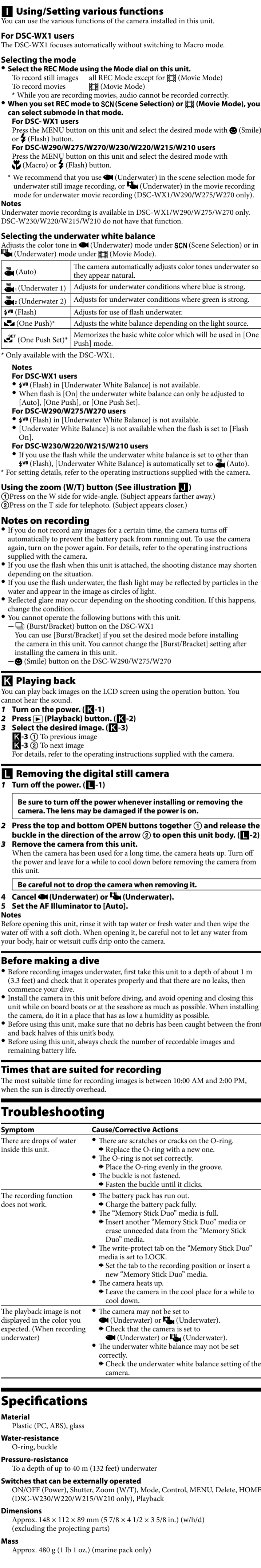
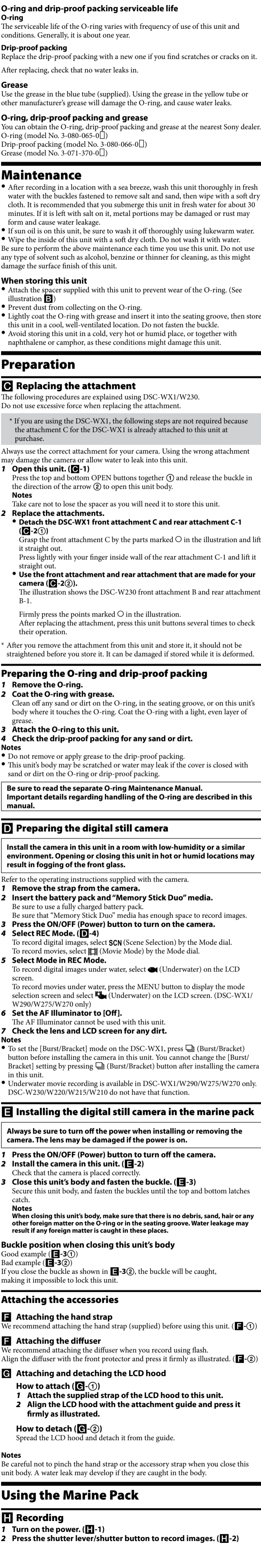
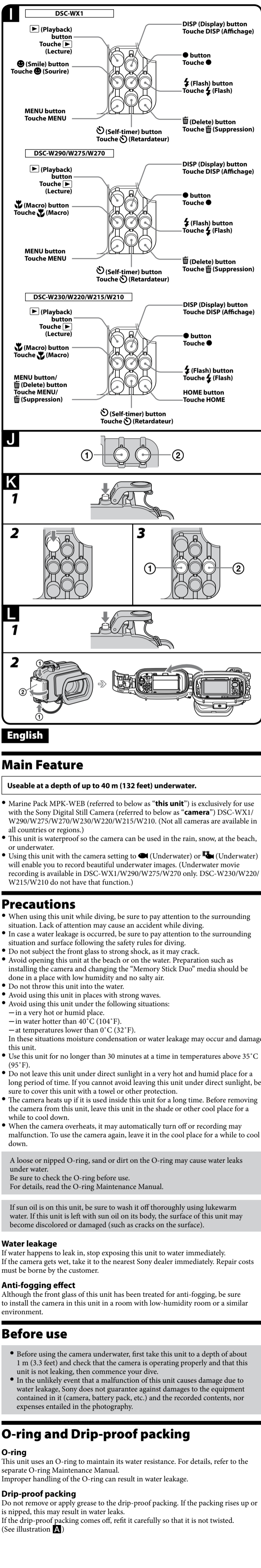
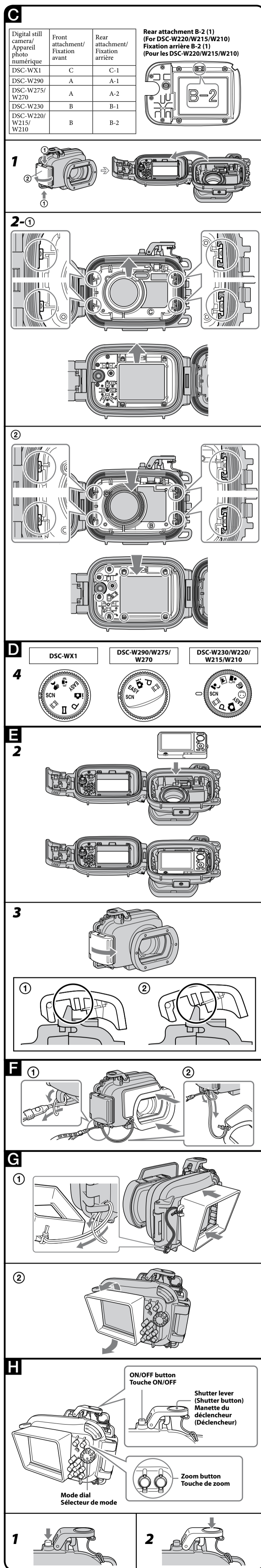
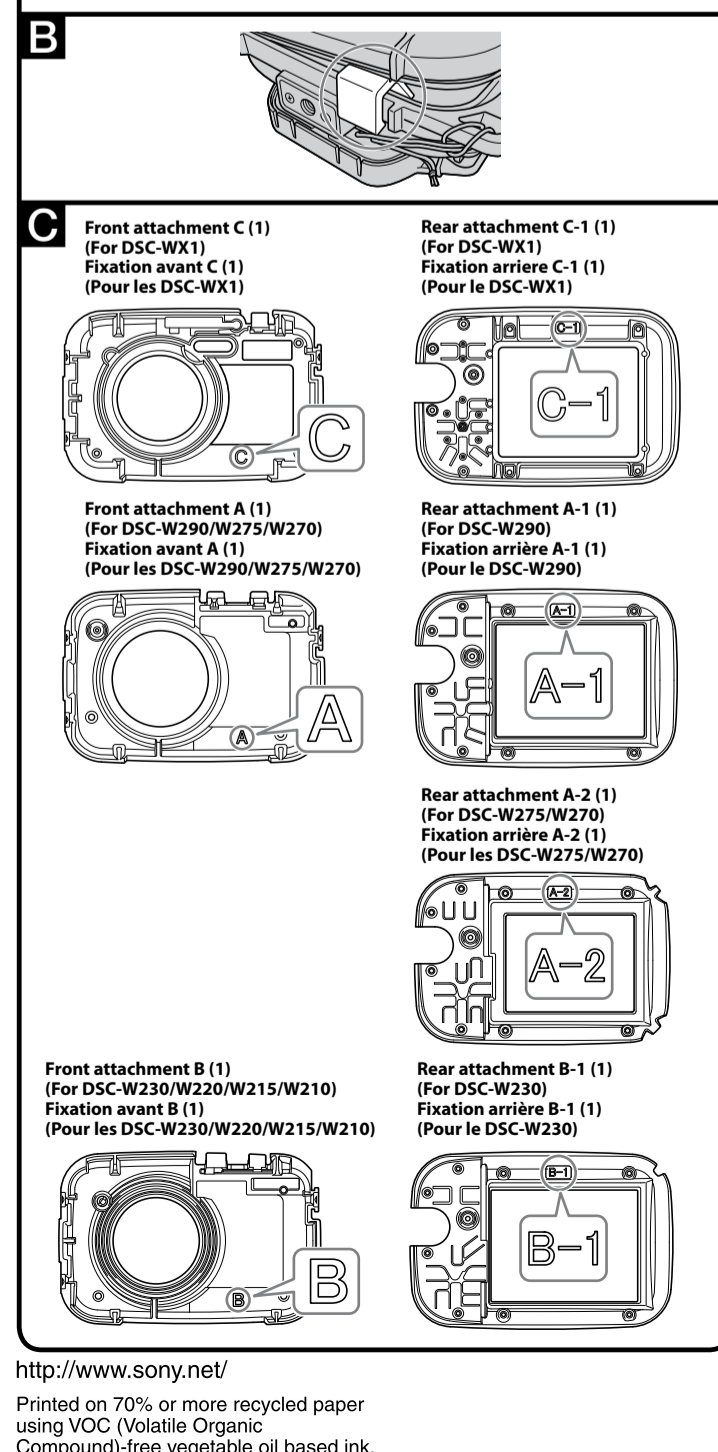
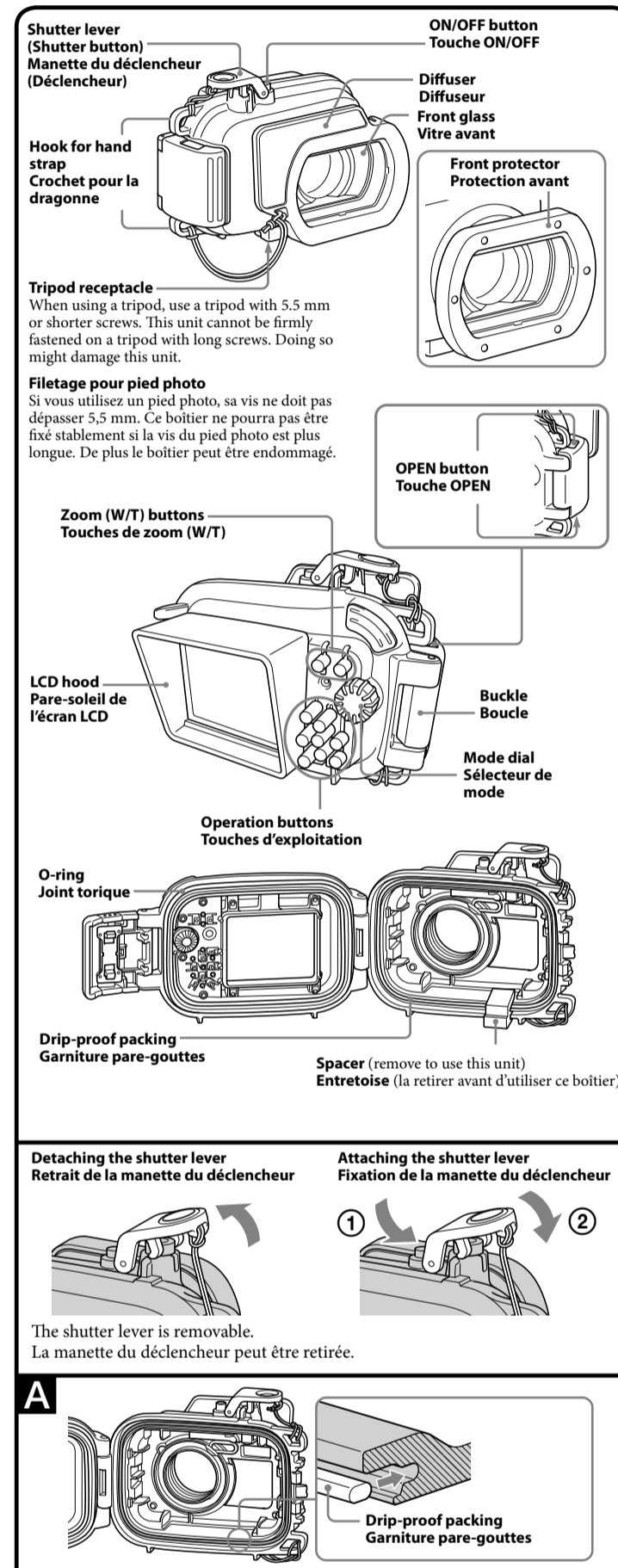

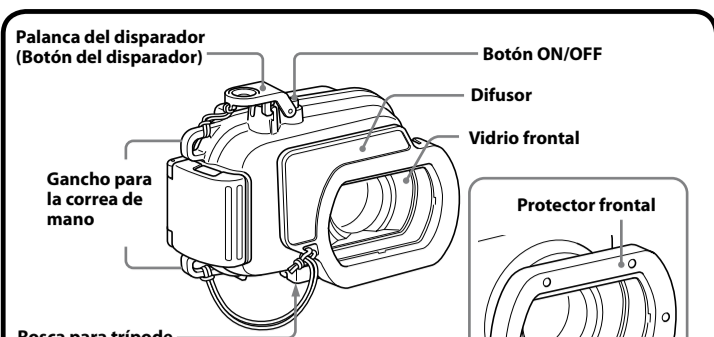

**Rosca para trípode**  
Cuando utilice un trípode, use uno con tornillo de 5,3 mm o más corto. Esta unidad no podrá fijarse firmemente a un trípode con tornillos largos. Si lo hiciese podría dañar esta unidad.

