

TOUR À MÉTAUX METAL LATH

550 W

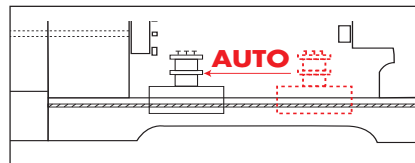

TOUR À MÉTAUX METAL LATHE		TDM 400
Gencode		3431541141353
Puissance du moteur Motor power		550 W 230V ~ 50Hz
Vitesses Speeds		X 12 160 - 1360 min ⁻¹
Mandrin autoserrant Keyless chuck		ø 1,5 - 13 mm
Poids Weight		179,50 kg
Capacité du mandrin du tour Metal lathe chuck capacity		ø 100 mm
A Entrepontes Distance between centre		420 mm
B Hauteur de pointe sur le banc Height of center over bed		210 mm
Filetage métrique Metric threading		0,2 - 3 mm
Filetage Anglais Withworth threading		8-120 TPI
Changement de vitesse Gear selection		Courroie Belt
Dimensions de la table Table sizes		200 X 150 mm
C Hauteur de pointe sur le chariot Height of center over carriage		160 mm
D Course du chariot longitudinale Longitudinal travel		380 mm
E Course du chariot transversale Cross travel		110 mm
F Capacité int/ext du mandrin de tournage Turning chuck ins/outside capacity		F1= 3-90 mm F2= 30-80 mm
G Cône morse de la poupée fixe Spindle bore		CM3 MT3
H Cône morse de la poupée mobile Morse taper of hole in tailstock		CM3 MT3
I Passage de broche de tournage Spindle bore		20 mm
W Distance banc - tête de broche Height of drill spindle over bed		250 mm
X Course de la tête Head stroke		80 mm
Y Cône morse de la broche Morse taper of spindle		CM3 + CM2 MT3 + MT2
Z Course de la broche Spindle stroke		80 mm



Avance automatique du chariot longitudinal
Feeding speed of the longitudinal carriage

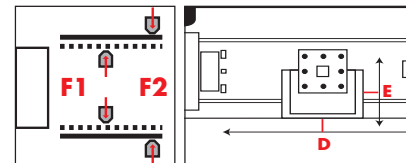

Mors intérieur et extérieur
Inside and outside jaws

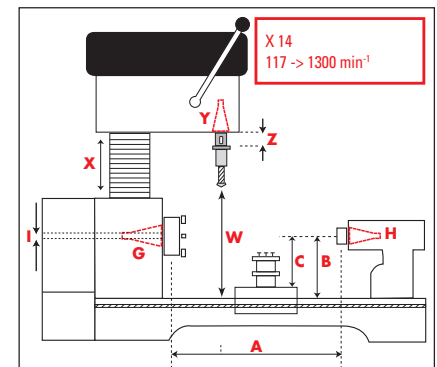

Livré avec un jeu de pignons pour filetage métrique et Anglais, 2 pointes sèches, un mandrin de tournage 100 mm avec mors intérieurs et extérieurs. Dimensions hors tout : 920x480x470 mm

Delivered with a set of metric and withworth threading pinions, 2 center points, one 100 mm turning chuck with inside and outside jaws. Overall sizes: 920x480x470 mm