



Quick Install Guide

DWL-3260AP
Managed Wireless Access Point

System Requirements:

Minimum System Requirements:

- CD-ROM Drive
- Computers with Windows, Macintosh, or Linux-based operating systems
- Installed Ethernet Adapter Internet Explorer version 6.0 or Netscape Navigator version 7.0 and above.

Package Contents



- **D-Link AirPremier™ DWL-3260AP** Managed Wireless Access Point
- Power over Ethernet base unit
- Power Adapter-DC 48V, 0.4A
- Power Cord
- Manual and Warranty on CD
- Quick Installation Guide
- Ethernet Cable
- Mounting Plate

Note: Using a power supply with a different voltage than the one included with the **DWL-3260AP** will cause damage and void the warranty for this product.

If any of the above items are missing, please contact your reseller.

Installing the Hardware



status LED

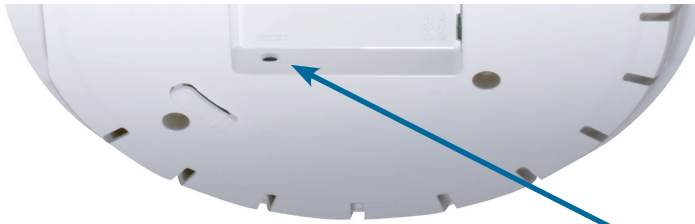

reset button



external antenna

Notice: DWL-3260AP has embedded antenna inside,if you need to use external antenna,please turn the switch button to Ext. and attach the antenna.

Connecting the Ethernet and Power Cables

The access point receives power through the Ethernet cable or an external power adapter. And also, this product intended only for installation in Environment A as defined in IEEE 802.3af, Power over Ethernet (PoE).

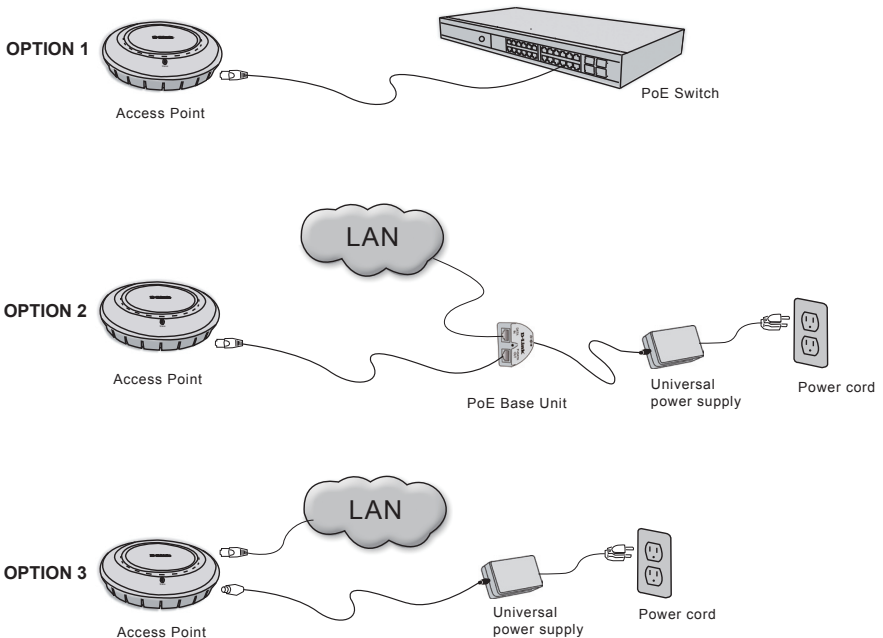

The access point power options:

Option 1: Connect with a D-Link wireless switch or other 802.3af PoE compliant switch.

Option 2: Use the PoE Base Unit to connect to a switch that lacks PoE capabilities.

Option 3: Connect to available power using the included power adapter .

Note: This product and all interconnected equipment must be installed indoors, including all associated LAN connections.

Physical Installation for Your Access Point:(optional)

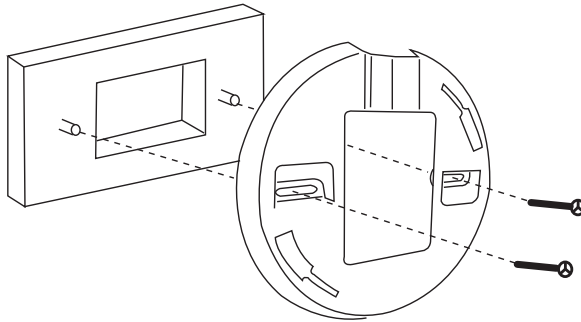

Junction Box Installation:

- 1.Attach the bracket to the junction box.
- 2.attach the DWL-3260AP to the mounting bracket.

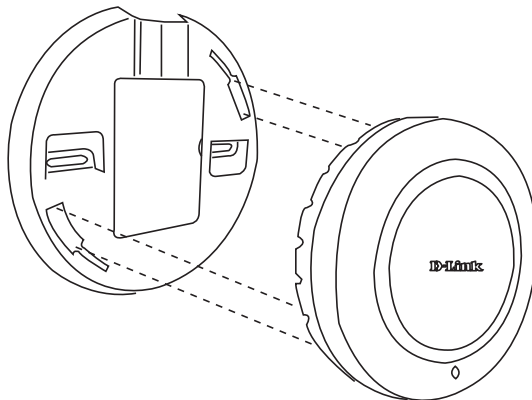

Solid Wall or Ceiling Installation:

- 1.Mount the bracket on the appropriate position on the wall or Ceiling.
- 2.Mount the AP to the bracket on the wall or ceiling.

Technical Support

You can find software updates and user documentation on the D-Link website.

Tech Support for customers within Australia:

D-Link Technical Support over the Telephone:

1300-766-868

Monday to Friday 8:00am to 8:00pm EST

Saturday 9:00am to 1:00pm EST

D-Link Technical Support over the Internet:

<http://www.dlink.com.au>

email: support@dlink.com.au

Tech Support for customers within New Zealand:

D-Link Technical Support over the Telephone:

0800-900-900

Monday to Friday 8:30am to 8:30pm

Saturday 9:00am to 5:00pm

D-Link Technical Support over the Internet:

<http://www.dlink.co.nz>

email: support@dlink.co.nz

D-Link®

Building Networks for People

Technical Support

You can find software updates and user documentation on the D-Link website.

Tech Support for customers within South Eastern Asia and Korea:

D-Link South Eastern Asia and Korea Technical Support over the Telephone:

+65-6895-5355

Monday to Friday 9:00am to 12:30pm, 2:00pm-6:00pm
Singapore Time

D-Link Technical Support over the Internet:

email:support@dlink.com.sg

D-Link[®]
Building Networks for People

Technical Support

You can find software updates and user documentation on the D-Link website.

Tech Support for customers within India

D-Link Technical Support over the Telephone:

+91-22-26526741

+91-22-26526696 –ext 161 to 167

Monday to Friday 9:30am to 7:00pm

D-Link Technical Support over the Internet:

<http://www.dlink.co.in>

<http://www.dlink.co.in/dlink/drivers/support.asp>

<ftp://support.dlink.co.in>

email: techsupport@dlink.co.in

D-Link[®]

Building Networks for People

Technical Support

You can find software updates and user documentation on the D-Link website.

D-Link provides free technical support for customers for the duration of the warranty period on this product.

Customers can contact D-Link technical support through our web site or by phone.

Tech Support for customers within the Russia

D-Link Technical Support over the Telephone:

(495) 744-00-99

Monday to Friday 10:00am to 6:30pm

D-Link Technical Support over the Internet:

<http://www.dlink.ru>

email: support@dlink.ru

D-Link[®]
Building Networks for People

Technical Support

You can find software updates and user documentation on the D-Link website.

Tech Support for customers within the U.A.E & North Africa:

D-Link Technical Support over the Telephone:

(971) 4-391-6480 (U.A.E)

Sunday to Wednesday 9:00am to 6:00pm GMT+4

Thursday 9:00am to 1:00pm GMT+4

D-Link Middle East & North Africa

D-Link Technical Support over the Internet:

<http://support.dlink-me.com>

email: support@dlink-me.com

Tech Support for customers within Israel:

D-Link Technical Support over the Telephone:

(972) 9-9715701

Sunday to Thursday 9:00am to 5:00pm

D-Link Technical Support over the Internet:

<http://www.dlink.co.il/support/>

e-mail: support@dlink.co.il

Tech Support for customers within Turkey:

D-Link Technical Support over the Telephone:

0090 312 473 40 55

Monday to Friday 9:00am to 6:00pm

D-Link Technical Support over the Internet:

<http://www.dlink.com.tr>

e-mail: turkiye@dlink-me.com

Tech Support for customers within Egypt:

D-Link Technical Support over the Telephone:

+202-2919035, +202-2919047

Sunday to Thursday 9:00am to 5:00pm

D-Link Technical Support over the Internet:

<http://support.dlink-me.com>

e-mail: amostafa@dlink-me.com

D-Link[®]
Building Networks for People

Technical Support

You can find software updates and user documentation on the D-Link website.

Tech Support for customers within South Africa and Sub Sahara Region:

D-Link South Africa and Sub Sahara Technical Support over the Telephone:

+27-12-665-2165

08600 DLINK (For South Africa only)

Monday to Friday 8:30am to 9:00pm South Africa Time

D-Link Technical Support over the Internet:

<http://www.d-link.co.za>

[email:support@d-link.co.za](mailto:support@d-link.co.za)

D-Link[®]
Building Networks for People

Technical Support

You can find software updates and user documentation on the D-Link website.

Tech Support for Latin America customers:

D-Link Technical Support over the followings Telephones:

Argentina: 0-800 122 35 465	Monday to Friday 09:00am to 22:00pm
Chile: 800-835465	Monday to Friday 08:00am to 21:00pm
Colombia: 01-800 952 54 65	Monday to Friday 07:00am to 20:00pm
Ecuador: 1800-035465	Monday to Friday 07:00am to 20:00pm
El Salvador: 800-6137	Monday to Friday 06:00am to 19:00pm
Guatemala: 1800-300 0017	Monday to Friday 06:00am to 19:00pm
Panama: 00-800 052 54 65	Monday to Friday 07:00am to 20:00pm
Peru: 0800-00 968	Monday to Friday 07:00am to 20:00pm
Venezuela: 0-800-100 5767	Monday to Friday 08:00am to 21:00pm

D-Link Technical Support over the Internet:

www.dlinkla.com
www.dlinklatinamerica.com
email:support@dlink.cl

Tech Support for customers within Brazil:

D-Link Technical Support over the Telephone:

0800 70 24 104
Monday to Friday 8:30am to 18:30pm

D-Link Technical Support over the Internet:

www.dlinkbrasil.com.br
email:suporte@dlinkbrasil.com.br

D-Link®
Building Networks for People



 **Руководство по быстрой
установке**

DWL-3260AP

Управляемая беспроводная точка доступа

Системные требования:

Минимальные системные требования:

- Привод CD-ROM
- Компьютеры с операционными системами Windows, Macintosh или Linux
- Установленный Ethernet-адаптер и Internet Explorer версии 6.0 или Netscape Navigator версии 7.0 или выше

Комплект поставки



- Управляемая беспроводная точка доступа **D-Link AirPremier™ DWL-3260AP**
- Базовое устройство PoE
- Адаптер питания – 48В постоянного тока, 0.4А
- Шнур питания
- Руководство пользователя и гарантия на компакт-диске
- Руководство по быстрой установке
- Кабель Ethernet
- Монтажная плата

Примечание: Использование источника питания с другими характеристиками может привести к повреждению **DWL-3260AP** и аннулированию гарантийных обязательств.

Если какой-либо из указанных предметов отсутствует, пожалуйста, обратитесь к поставщику.

Установка устройства



Индикатор status



Кнопка reset



внешняя антенна

Замечание: DWL-3260AP имеет встроенную антенну, но если необходимо использовать внешнюю антенну, пожалуйста переключите кнопку в положение Ext. и подключите антенну.

Подключение кабеля питания и Ethernet-кабеля Cables

Точка доступа получает питание через кабель Ethernet или внешний адаптер питания. Это устройство предназначено для подключения только в соответствии с методом Alternative A, как определено стандартом IEEE 802.3af, Power over Ethernet (PoE).

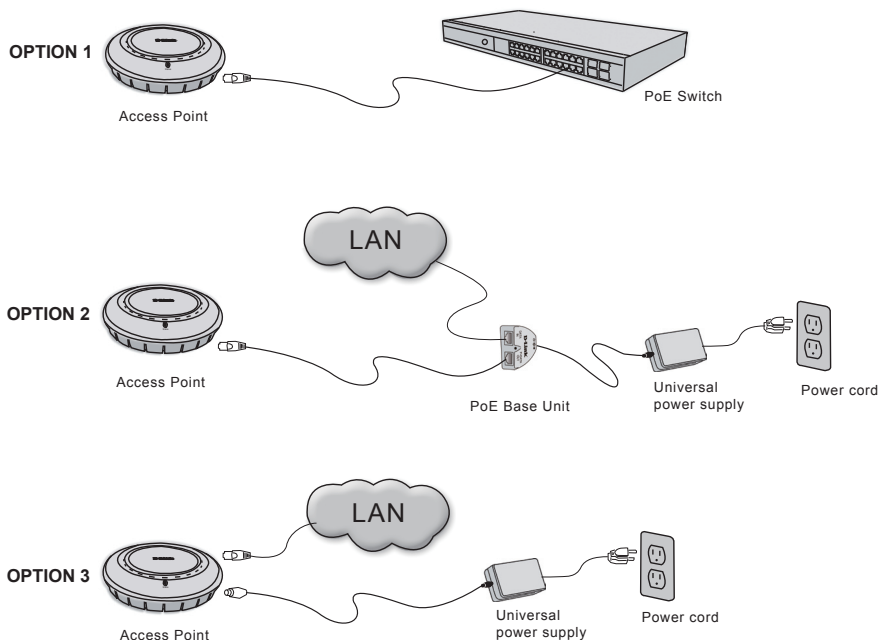

Варианты подключения питания точки доступа:

Вариант 1: Подключение к беспроводному коммутатору D-Link или к другому коммутатору, совместимому с 802.3af PoE.

Вариант 2: Подключение к коммутатору, не поддерживающему стандарт PoE, при помощи базового устройства PoE.

Вариант 3: Подключение к электрической розетке с помощью адаптера питания (входит в комплект поставки).

Замечание: Этот продукт и все оборудование должны быть установлены внутри помещения, включая все сетевые соединения.

Физическая установка точки доступа: (дополнительно) Point:(optional)

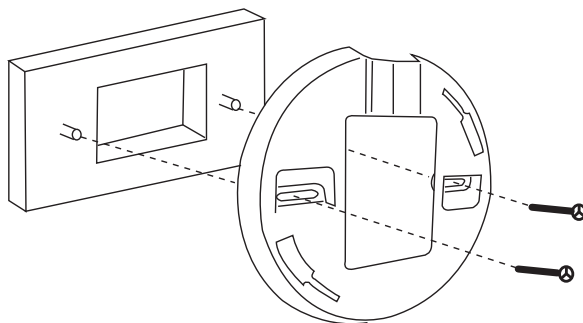

Установка соединительной коробки:

1. Прикрепите скобу к соединительной коробке.
2. Прикрепите DWL-3260AP к монтажной плате.

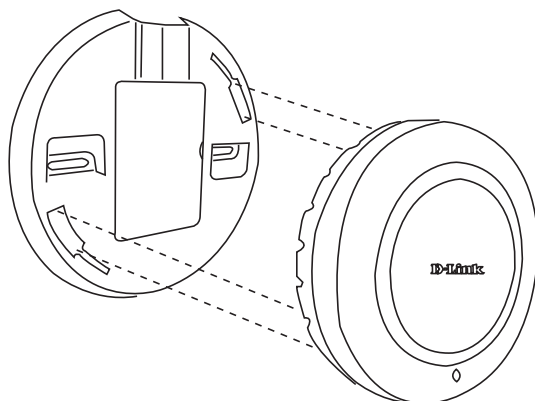

Установка точки доступа на стену или потолок:

1. Закрепите скобы в подходящем месте на стене или потолке.
2. Закрепите точку доступа скобами к стене или потолку.

Техническая поддержка

Обновления программного обеспечения и документация доступны на Интернет-сайте D-Link.

D-Link предоставляет бесплатную поддержку для клиентов в течение гарантийного срока.

Клиенты могут обратиться в группу технической поддержки D-Link по телефону или через Интернет.

Техническая поддержка D-Link:

(495) 744-00-99

Техническая поддержка через Интернет

<http://www.dlink.ru>

email: support@dlink.ru

D-Link®
Building Networks for People



Guía de instalación rápida

DWL-3260AP

Punto de acceso inalámbrico gestionable

Requisitos del sistema:

Requisitos mínimos del sistema:

- Unidad de CD-ROM.
- Ordenadores con sistemas operativos Windows, Macintosh o basados en Linux.
- Adaptador Ethernet instalado Internet Explorer versión 6.0 o Netscape Navigator versión 7.0 y superiores.

Contenido del paquete



- Punto de acceso inalámbrico gestionable **D-Link AirPremier™ DWL-3260AP**
- Unidad base Power over Ethernet.
- Adaptador de alimentación DC 48 V, 0,4 A
- Cable de alimentación
- Manual y garantía en el CD-ROM.
- Guía de instalación rápida.
- Cable Ethernet.
- Placa de montaje

Nota: El uso de una fuente de alimentación con distinto voltaje a la incluida con el **DWL-3260AP** puede ser perjudicial y anular la garantía de este producto.

Si falta alguno de estos componentes, contacte con su proveedor.

Instalación del hardware



LED de estado

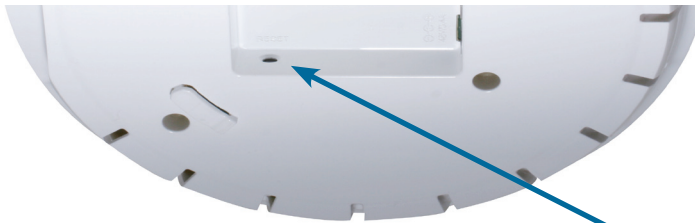

Botón reset



Antena externa

Aviso: DWL-3260AP dispone de una antena integrada; si necesita usar una antena externa, ponga el botón en Ext. y conecte la antena.

Conexión de los cables de alimentación y Ethernet

El punto de acceso recibe la alimentación a través del cable Ethernet o de un adaptador de alimentación externo. Además, este producto está pensado sólo para instalarlo en entornos A, como define IEEE 802.3af, Power over Ethernet (PoE).

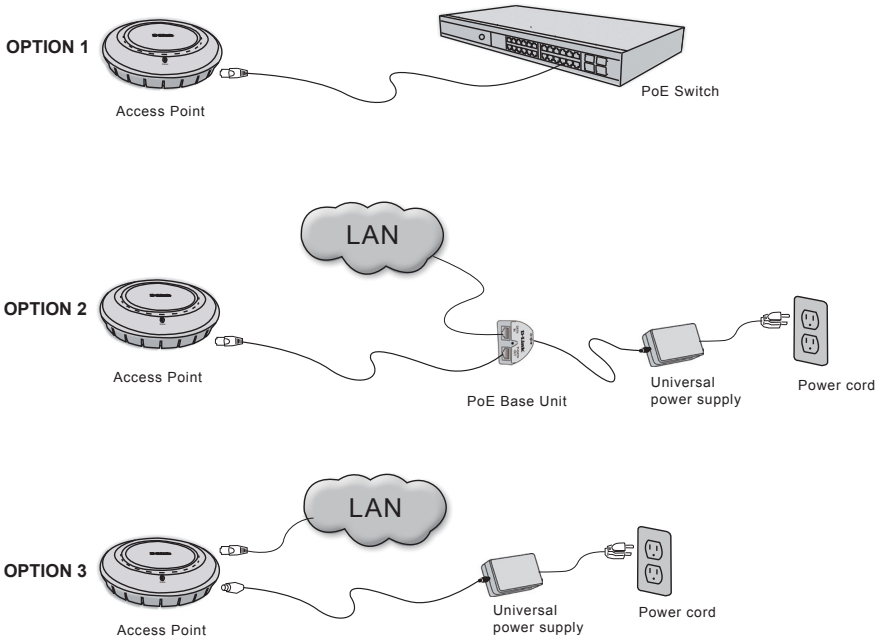

Opciones de alimentación del punto de acceso:

Opción 1: Conectarlo a un conmutador inalámbrico D-Link u otro conmutador acorde con 802.3af PoE.

Opción 2: Usar la unidad base PoE para conectarlo a un conmutador que carezca de capacidad PoE.

Opción 3: Conectarlo a una toma eléctrica por medio del adaptador de alimentación incluido con el producto.

Nota: Este producto y todos los equipos interconectados han de instalarse en interiores, incluidas todas las conexiones LAN asociadas.

Instalación física del punto de acceso: (opcional)

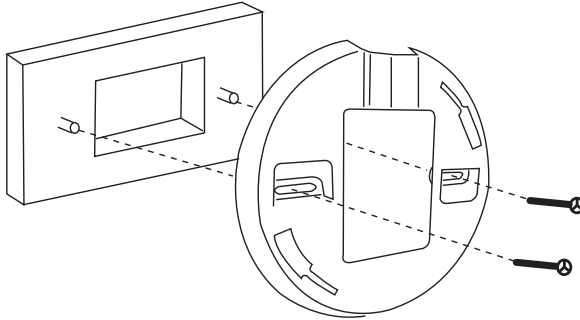

Instalación en caja de conexiones:

1. Fije el ángulo a la caja de conexiones.
2. Fije el DWL-3260AP al ángulo de montaje.

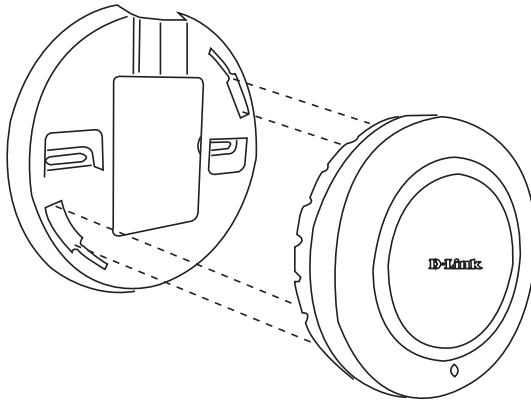

Instalación en pared o techo:

1. Monte el ángulo en la posición adecuada sobre la pared o el techo.
2. Fije el punto de acceso al ángulo de montaje de la pared o del techo.

Asistencia Técnica

D-Link Latin América pone a disposición de sus clientes, especificaciones, documentación y software mas reciente a través de nuestro Sitio Web www.dlinkla.com

El servicio de soporte técnico tiene presencia en numerosos países de la Región Latino América, y presta asistencia gratuita a todos los clientes de D-Link, en forma telefónica e internet, a través de la casilla soporte@dlinkla.com

Soporte Técnico Help Desk Argentina:

Teléfono: 0-800 122 35 465 Lunes a Viernes 09:00 am a 22:00 pm

Soporte Técnico Help Desk Chile:

Teléfono: 800 8 35465 Lunes a Viernes 08:00 am a 21:00 pm

Soporte Técnico Help Desk Colombia:

Teléfono: 01-800 952 54 65 Lunes a Viernes 07:00 am a 20:00 pm

Soporte Técnico Help Desk Ecuador:

Teléfono: 1800-035465 Lunes a Viernes 07:00 am a 20:00 pm

Soporte Técnico Help Desk El Salvador:

Teléfono: 800-6137 Lunes a Viernes 06:00 am a 19:00 pm

Soporte Técnico Help Desk Guatemala:

Teléfono: 1800-300 0017 Lunes a Viernes 06:00 am a 19:00 pm

Soporte Técnico Help Desk Panamá:

Teléfono: 00-800 052 54 65 Lunes a Viernes 07:00 am a 20:00 pm

Soporte Técnico Help Desk Perú:

Teléfono: 0800-00 968 Lunes a Viernes 07:00 am a 20:00 pm

Soporte Técnico Help Desk Venezuela:

Teléfono: 0-800-100 5767 Lunes a Viernes 08:00 am a 21:00 pm



Guia de Instalação Rápida

DWL-3260AP
Access Point Wireless Gerenciável

Requisitos Mínimos do Sistema

Requisitos Mínimos do Sistema:

- Drive de CD-ROM
- Computador com Sistema Operacional Windows, Macintosh, ou Linux.
- Adaptador Ethernet Instalado, Internet Explorer 6.0 ou Netscape 7.0 e superior

Conteúdo da Embalagem



- Access Point Gerenciável **D-Link AirPremier™ DWL-3260AP**
- Unidade Base PoE
- Adaptador de Energia DC 48V, 0.4A
- Cabo de Energia
- Manual e Garantia no CD
- Guia de Instalação Rápida
- Cabo Ethernet
- Suporte de Montagem

Nota: Usar uma fonte de energia com a voltagem diferente, pode danificar o produto e violar a garantia.

Se algum desses itens estiver faltando, por favor entre em contato com a sua revenda.

Instalando o Hardware



LED de Status



Botão Reset



Antena Externa

Nota: O DWL-3260AP possui uma antena interna embutida, caso seja necessário o uso de antena externa, vire o botão Ext e conecte a antena.

Conectando os Cabos Ethernet e de Energia

O access point recebe energia através do cabo Ethernet ou adaptador de energia externo. Este produto também é recomendado para instalação em um ambiente A como definido no IEEE 803.3af, Power over Ethernet (PoE).

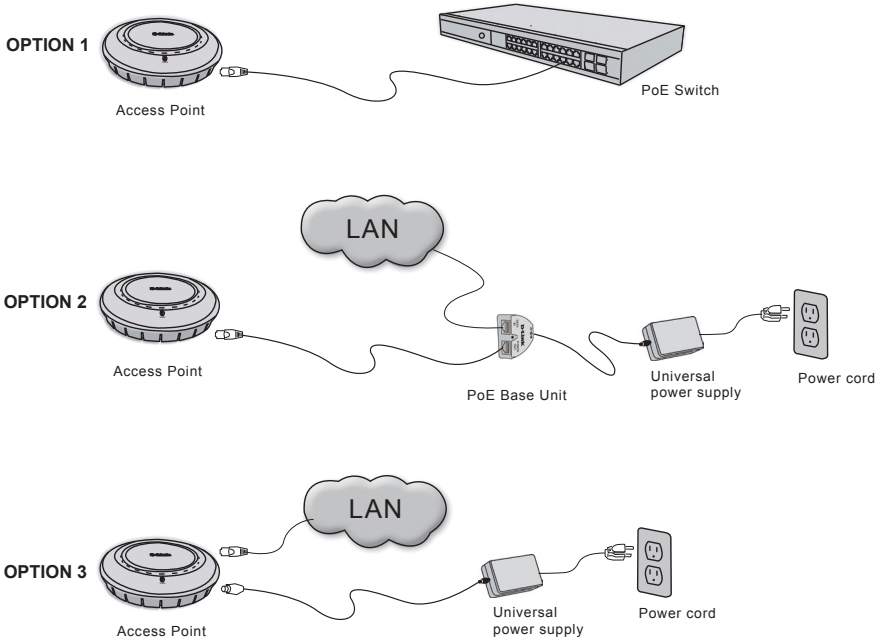

Opções de Energia do Access Point:

Opção 1: Conecte com um Wireless Switch D-Link ou outro Switch compatível com 802.3af PoE .

Opção 2: Utilize a unidade base PoE para conectar a um Switch que não tenha compatibilidade com PoE.

Opção 3: Conecte a uma tomada de energia disponível através da fonte de energia incluída.

Nota: Este produto e todos os equipamentos de interconexão podem ser instalados em ambientes internos, incluindo todas as conexões LAN associadas.

Instalação Física para o seu Access Point (opcional)

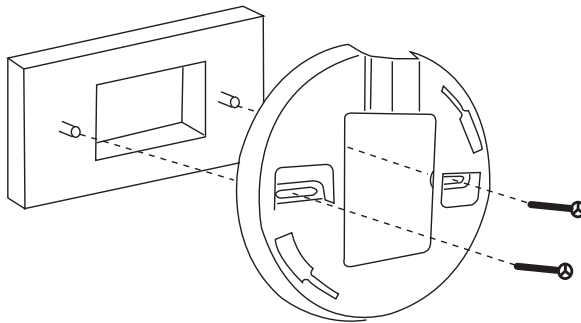

Instalação da Caixa de Junção:

1. Conecte o suporte a caixa de junção
2. Conecte o DWL-3260AP ao suporte de montagem

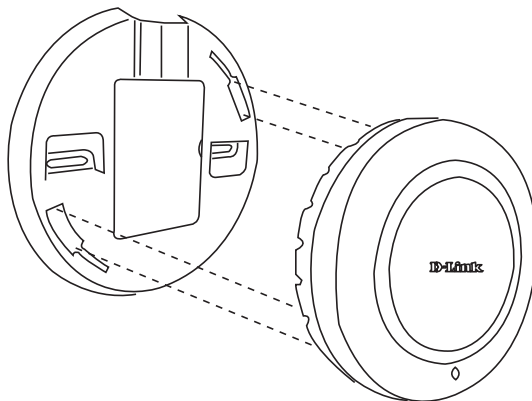

Instalação em Parede ou Teto:

1. Coloque o suporte na posição apropriada sobre a parede ou teto
2. Monte o AP no suporte sobre a parede ou teto.

Suporte Técnico

Você pode encontrar atualizações de software e documentação de usuário no site da D-Link Brasil www.dlinkbrasil.com.br.

A D-Link fornece suporte técnico gratuito para clientes no Brasil durante o período de vigência da garantia deste produto.

Suporte Técnico para clientes no Brasil:

Telefone

São Paulo (11) 2185-9301

Segunda à sexta

Das 8h30 às 18h30

Demais Regiões do Brasil 0800 70 24 104

E-mail:

email:suporte@dlinkbrasil.com.br

D-Link®
Building Networks for People



■ ■ 快速安裝手冊

DWL-3260AP
無線基地台

系統需求：

最小系統需求：

- 光碟機
- 具備Windows, Mac, 或是Linux based其中一種作業系統之電腦
- 具備乙太網路卡
- 系統具備Internet Explorer version 6.0 或 Netscape Navigator version 7.0 或更新

產品包裝清單



- D-Link AirPremier™ DWL-3260AP 無線基地台
- 網路供電轉換器(PoE Base Unit)
- 電源供應器 DC48V, 0.4A
- 電源纜線
- 光碟片內含設備操作手冊
- 快速安裝手冊
- 乙太網路線
- 設備固定架

備註：使用不同電壓的電源供應器可能造成DWL-3260AP設備發生故障，若使用非原廠電源供應器使設備故障將失去產品保固。

購買時若有任何配件缺失敬請與購買的經銷商聯繫。

設備硬體安裝



狀態指示燈號

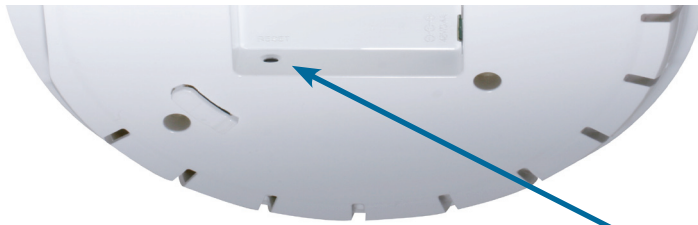

設備重置案件



外接式天線插座

備註：DWL-3620AP具備內建式天線，若您選擇外接式天線時，敬請切換天線插座左側之切換開關。

連接乙太網路線與電源線

DWL-3260AP 無線基地台可透過乙太網路線或是外接式電源供應器供應所需的電源。建議電源安裝方式為透過IEEE802.3af PoE 網路供電。

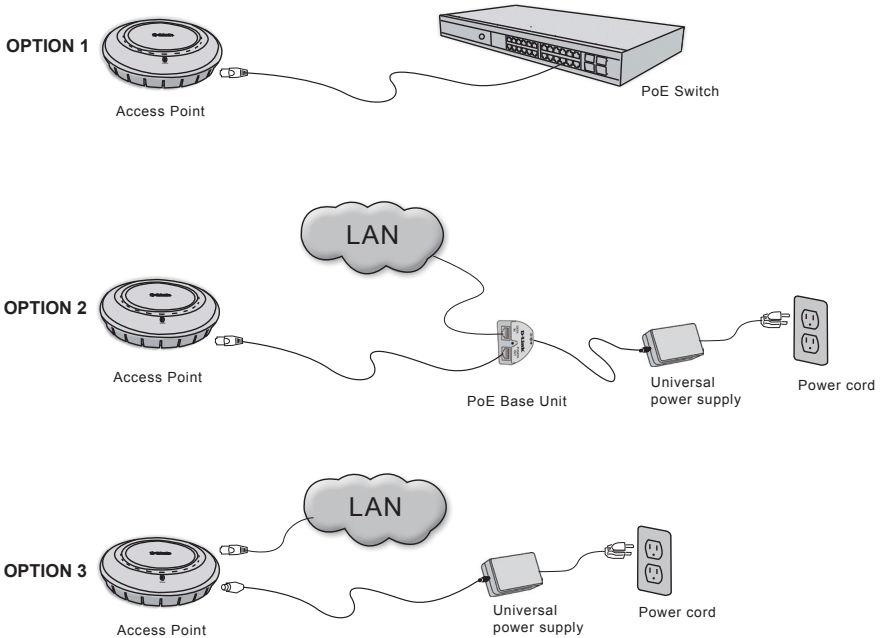

無線基地台電源安裝方式:

方式1: 與D-Link Wireless switch或其他具備802.3af的網路交換器直接連接。

方式2: 使用網路供電轉換器提供DWL-3260AP所需的電源

方式3: 透過產品包裝內附的電源供應器提供設備所需的電源。

備註: 本產品為室內型無線基地台請勿安裝於室外環境使用包含電源與網路線。

您的無線基地台實體安裝方式 (Optional)

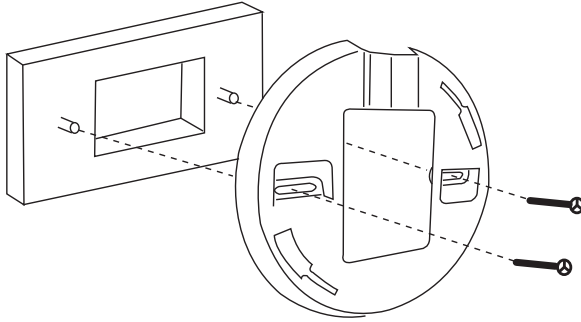

固定盒安裝方式：

- 1.請將設備托架固定在固定盒上。
- 2.再將DWL-3260AP固定再設備托架上。

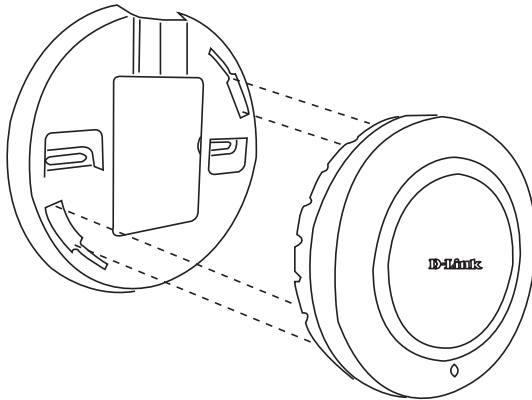

牆壁與天花板安裝方式：

- 1.將設備備托架固定在天花板牆壁等適當之位置。
- 2.將無線基地台安裝於固定在天花板或牆壁上之設備托架上。

D-Link 友訊科技 台灣分公司 技術支援資訊

如果您還有任何本使用手冊無法協助您解決的產品相關問題，台灣地區用戶可以透過我們的網站、電子郵件或電話等方式與D-Link台灣地區技術支援工程師聯絡。

D-Link 免付費技術諮詢專線

0800-002-615

服務時間：週一至週五，早上8:30 到 晚上7:00

(不含周六、日及國定假日)

網 站：<http://www.dlink.com.tw>

電子郵件：dssqa_service@dlink.com.tw

如果您是台灣地區以外的用戶，請參考D-Link網站 全球各地分公司的聯絡資訊以取得相關支援服務。

產品保固期限、台灣區維修據點查詢，請參考以下網頁說明：

<http://www.dlink.com.tw>

產品維修：

使用者可直接送至全省聯強直營維修站或請洽您的原購買經銷商。

D-Link[®]
Building Networks for People

D-Link[®]



Ver. 1.00 (I)
2007/04/23
6WL3260QML01G